

March 28, 1961

R. A. YONKERS ET AL

2,976,559

APPARATUS FOR APPLYING DETERGENT TO RUGS AND THE LIKE

Filed Oct. 17, 1957

2 Sheets-Sheet 1

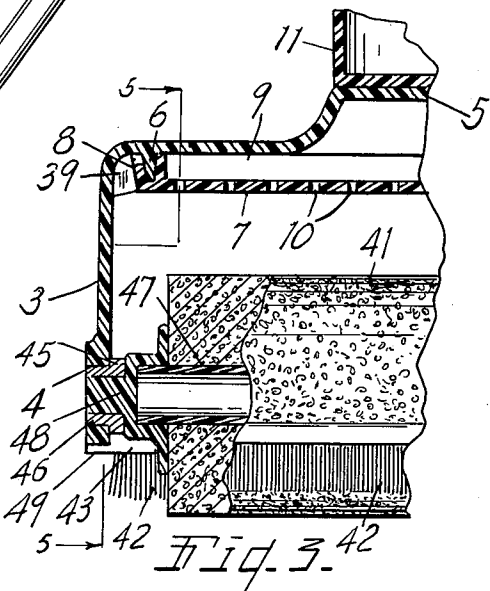
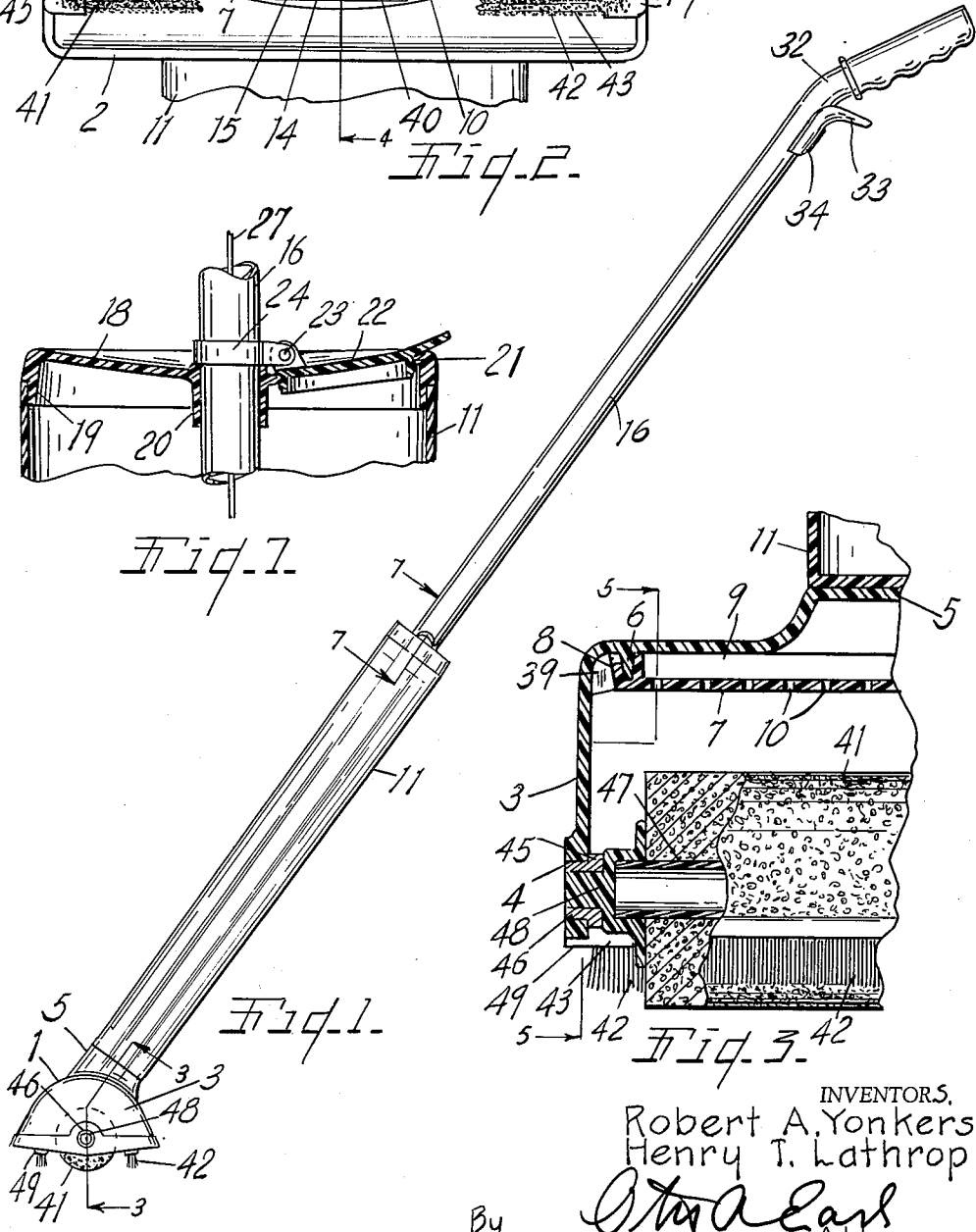
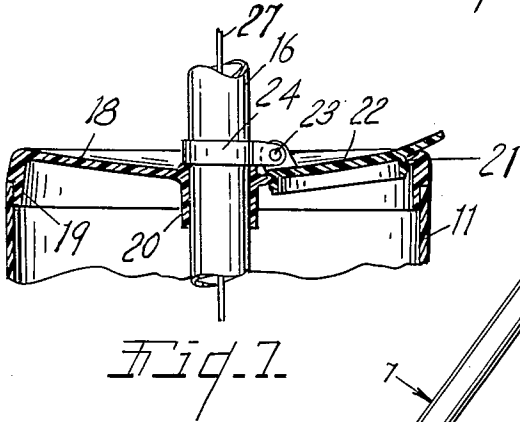
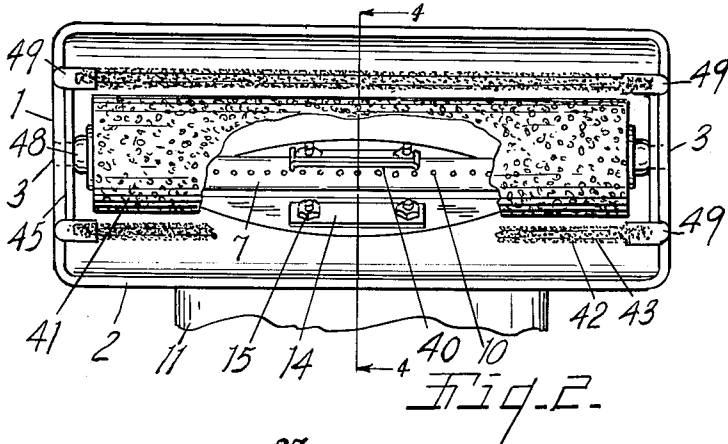

INVENTORS,  
 Robert A. Yonkers  
 Henry T. Hathrop

By *Stadler*  
 Attorney

March 28, 1961

R. A. YONKERS ET AL

2,976,559

APPARATUS FOR APPLYING DETERGENT TO RUGS AND THE LIKE

Filed Oct. 17, 1957

2 Sheets-Sheet 2

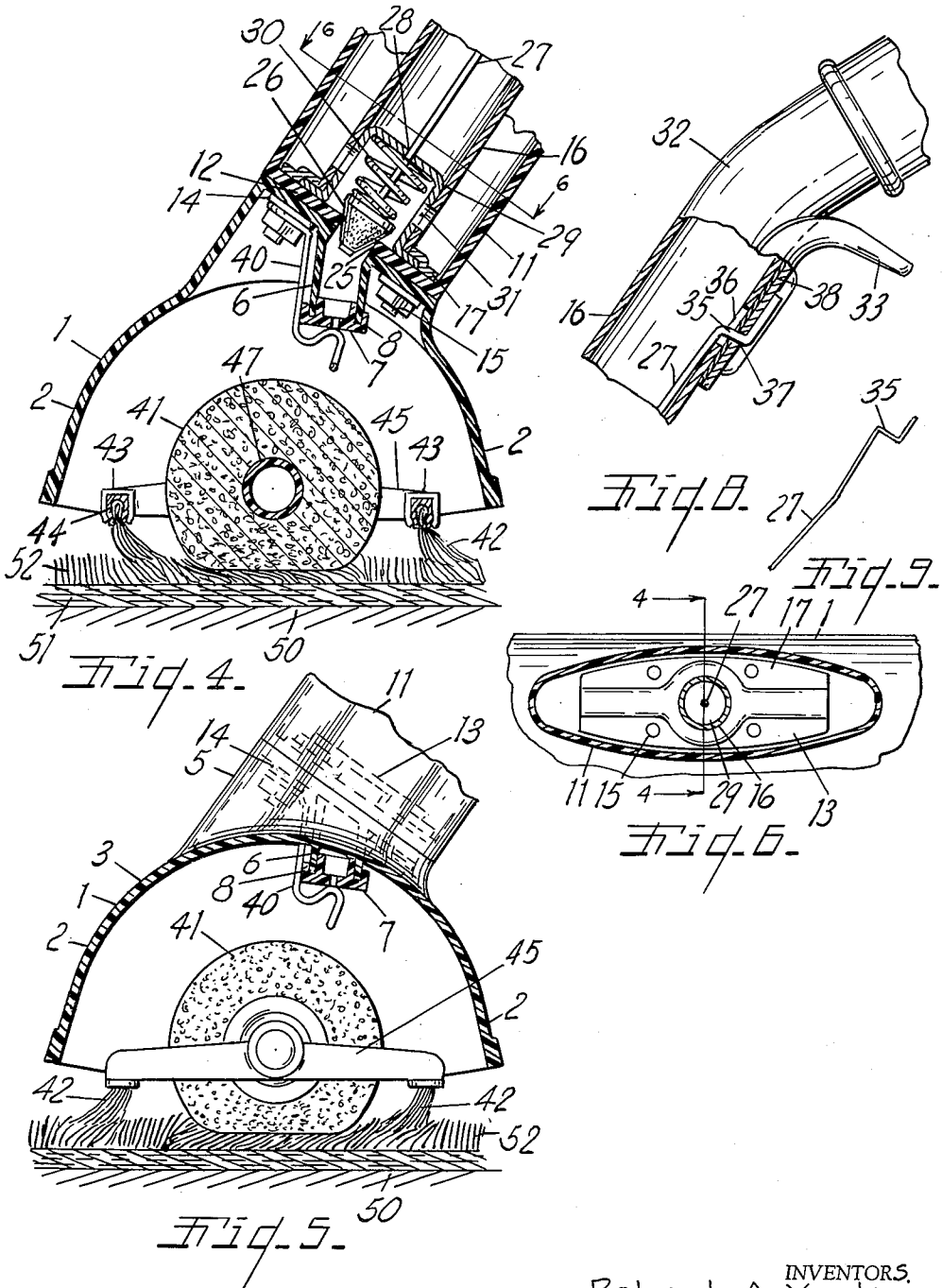

Fig. 2.

Fig. 3.

Fig. 6.

Fig. 5.

INVENTORS.  
Robert A. Yonkers  
Henry T. Lathrop

By *Charles*  
Attorney.

1

2,976,559

**APPARATUS FOR APPLYING DETERGENT TO RUGS AND THE LIKE**

Robert A. Yonkers and Henry T. Lathrop, Grand Rapids, Mich., assignors to Bissell Inc., a corporation of Michigan

Filed Oct. 17, 1957, Ser. No. 690,722

11 Claims. (Cl. 15—532)

This invention relates to a device or apparatus for applying detergents to surfaces, particularly rugs, carpets or like articles having nap and working the detergent into the nap in a foaming condition or producing a foaming condition in the nap.

The present invention constitutes an improvement in structural details upon the apparatus described and claimed in copending application Serial No. 660,807, filed May 22, 1957, by the present inventors, whereby certain manufacturing economies are attained and improved operation is provided.

In the construction illustrated in the foregoing application the apparatus has a molded channel shaped body member facing downwardly and having a top which constitutes the bottom of a receptacle and which has a longitudinal distributing tube with downward discharge ports and an upward facing valve seat. A synthetic sponge roller of substantial radial thickness of material and substantial resilience is journaled in the body member and supports the latter for translation over a rug. Brushes are provided fore and aft of the roller and carried by the lower edges of the walls of the member. A handle is provided in two parts, one extending from the valve seat up through the receptacle and the other extending upwardly from the first to a suitable hand grip for the operator, the two parts being secured together by a bayonet joint. The receptacle was filled through the hollow handle. The valve was actuated by a rod extending upwardly through the two parts of the handle to a finger ring beneath the hand grip. The valve actuating rod was in two sections corresponding to the two parts of the handle, and assembly of the same was found to be difficult.

The present invention provides a one piece full length handle which eliminates assembly problems and gives a more positive and accurate valve actuation by reason of the rod extending in one piece from the valve to a slide trigger adjacent the hand grip.

The distributing tube is made with a separately molded face having the discharge ports therein and which face preferably may be removed for cleaning purposes. The receptacle is made with an integral bottom to avoid leakage problems and is removably secured upon the body member. It has a covered inlet at the top.

The roller and brushes are carried by a sub-assembly frame which is removably held in the body member as a unit, and the roller extends downwardly beyond the plane of the actuating face of the brush bristles to provide greater deflection of the sponge-like material of the roller and consequent greater foaming action.

A preferred embodiment of the invention is illustrated in the accompanying drawing, in which:

Fig. 1 is a side elevational view of an applicator embodying our invention.

Fig. 2 is a fragmentary bottom view.

Fig. 3 is an enlarged fragmentary view partially in section on a line corresponding to broken line 3—3 of Fig. 1.

2

Fig. 4 is a fragmentary view mainly in section on a line corresponding to line 4—4 of Fig. 2, illustrating the applicator in operative relation to a rug or the like.

Fig. 5 is a similar view partially in section on a line corresponding to line 5—5 of Fig. 3, the applicator being illustrated as moving on a reverse stroke from that illustrated in Fig. 4.

Fig. 6 is a reduced fragmentary view in section on a line corresponding to line 6—6 of Fig. 4.

Fig. 7 is an enlarged fragmentary view partially in section on a line corresponding to line 7—7 of Fig. 1.

Fig. 8 is a fragmentary side elevational view of the upper end of the handle partially in longitudinal section.

Fig. 9 is a fragmentary side elevational view of the upper end of the valve control rod or stem prior to its engagement with associated parts as illustrated in Fig. 8.

The applicator is designed for and is desirable for use in the application of a wide variety of detergent containing liquids to the rug or other nap surface being cleaned, it is particularly desirable for use in the application of detergents having the characteristic of foaming on agitation thereof and the working of the detergent material into the nap in such foaming condition. It is the applicant's observation and experience that the working of the detergent into the nap in the form of foam avoids excessive wetting of the rug, and the foamed detergent loosens the dirt and other foreign matter to be removed, and tends to collect it so that when dry the foreign matter may be readily removed by a carpet sweeper, a suction cleaner, or the like.

In the accompanying drawing 50 represents a floor, 51 a rug backing or base and 52 the nap thereof. In the embodiment of our invention illustrated, the body member 1 is desirably formed integrally of a thermoplastic resin. The body member is elongated transversely of its path of travel when in use, and comprises side walls 2 and end walls 3 which are somewhat springable and have aligned openings 4 therein adjacent their lower edges. The body member has a rearwardly declined top portion 5 which has a flat outer surface. On its inner side the top is provided with an integral channel-like conduit member 6 extending longitudinally thereof and terminating in spaced relation to the end walls, as is illustrated in Fig. 3. The face member 7 is provided with grooves 8 on its edges adapted to receive the edges of the conduit member 6 on the body and coact therewith to provide a liquid distributing conduit 9 extending longitudinally of the body member. The face member 7 is provided with a series of uniformly spaced discharge openings 10.

The detergent receptacle 11 has a bottom portion 12 seated upon the rearwardly declined top surface 5 and fixedly secured thereto as by means of the clamping plate 13 arranged within the receptacle and the plates 14 arranged within the body member and the bolts 15, see Figs. 2, 4 and 6. The liquid receptacle is preferably also formed of thermoplastic resin and is of oval cross section.

The tubular handle 16 is provided with a flange 17 at its lower end which is engaged by the clip or clamping member 13 so that the body member, handle and the receptacle are fixedly connected. The receptacle is provided with a top 18 having flanged edges 19 telescopically engaging the upper end of the receptacle, the top member having a portion 20 sleeved upon the handle. The receptacle top has a filling opening 21 provided with a closure 22 which, in the embodiment illustrated, is hinged at 23 to the support 24 clamped around the handle above the cover of the receptacle.

The bottom of the receptacle is provided with a discharge opening 25 with which the valve 26 coacts to control the discharge of liquid to the distributing conduit 9. The valve is provided with an elongated stem or control

3

rod 27 which is passed through a hole 28 in the top of the valve cage 29, keeping the valve in proper centered relation to the port. The valve is urged to its seat by the coiled spring 30. The cage 29 and the handle 16 are provided with aligned openings 31 for the passage of the cleaning fluid from the receptacle 11 into the valve cage 29.

The handle 16 is provided with an angularly disposed grip portion 32 at its upper end. The valve stem or control rod 27 is provided with a finger piece 33 which has a body portion 34 cross-sectionally conformed to slidably engage the side of the handle, as is illustrated in Figs. 1 and 8. The control rod 27 or valve stem has an angled offset 35 disposed through the slot 36 in the handle and through an opening 37 in the fingerpiece, as is illustrated in Fig. 8. This offset portion 35 of the valve control rod or stem 27 is conformed as shown in Fig. 9 and is springably forward so that when engaged as is shown in Fig. 8, it serves the double purpose or function of connecting the control rod to the finger piece and also holding the finger piece body portion 24 frictionally against the handle. A friction reducing strip 38 is disposed between the body portion 34 of the finger piece and the handle 16, as is illustrated in Fig. 8. It will be understood that the valve closing spring is of sufficient tension to seat the valve when the finger piece is released.

The face member 7 of the conduit 9 is releasably engaged with the portion 6 of the conduit formed integrally with the body member 1 and is retained in engaged position by the lugs 39 disposed on the end walls, see Fig. 3, and by the spring clip 40 which is centrally disposed and secured to the declining top portion 5 of the body member 1 by the bolts 15. This clip, in the embodiment illustrated, is of general U-shape and has an offset bight portion springably engaging the underside of the conduit face member 7, as is clearly illustrated in Figs. 4 and 5.

The applicator roller 41 is positioned to receive the discharge from the conduit. In the embodiment illustrated, the roller 41 and the brushes 42 are assembled on a supporting frame as a unit. The supporting frame comprises the side members 43 of downwardly facing channel section receiving the heads 44 of the brushes, see Fig. 4, and end members 45 which are provided with bearing members 46 detachably engageable with the openings 4 in the end walls 3 of the body member 1, see Figs. 1, 3 and 5. The end walls 3 may be sprung to permit engagement and disengagement of the bearing members 46 therewith.

It will be noted that the roller substantially projects below the brushes when it is not under compression stress, see Figs. 1 and 3. The roller is provided with a core 47 of relatively small diameter compared to the diameter of the roller, and the ends of the core project into the journals 48 which are recessed to receive the ends of the core and flanged to supportably engage the ends of the roller.

The roller 41 is formed of resiliently compressible spongy material such as sponge rubber, and is capable of absorbing a substantial quantity of liquid containing a detergent discharged thereon from the conduit 9. The roller is resiliently compressible to such degree as to discharge the liquid absorbed thereby upon the surface, over which the roller is translated and such squeezing or compression stresses, as is illustrated in Figs. 4 and 5, result in agitating the liquid in the sponge so that it is deposited on the nap or surface in a foamed or semi-foamed condition, the brushes coacting to further that condition and also to work the detergent into the nap.

The desirable method of using the apparatus is to reciprocate it under roller deforming pressure back and forth across the surface to be cleaned, as is indicated in Figs. 4 and 5. In the uncompressed condition the roller projects substantially below the bristles, as is indicated in Figs. 1 and 3. By reason of the greater thickness of sponge material on the roller and the above described position-

4

ing of roller 41 relative to the brushes 42 and body member 1, a greater foaming action is obtained from the greater deformation of the sponge during translation of the apparatus to and fro over the nap 52 of rug backing 51. There is less danger of liquid wetting of the rug backing or base.

The combined brush and roller support frame is provided with lugs 49 which engage the lower edges of the end walls 3 when the combined support and bearing members 46 are engaged with the end walls.

The embodiment of our invention illustrated is relatively light and easily manipulated and is highly efficient, and is a desirable commercial embodiment.

We have not illustrated other embodiments thereof, as it is believed that this disclosure will enable those skilled in the art to embody or adapt our invention as may be desired.

Having thus described the invention, what is claimed as new and desired to be secured by Letters Patent is:

1. An apparatus of the class described comprising an elongated body member of downwardly facing channel section having end walls, said body member having an elongated longitudinally extending liquid discharge conduit therein provided with a spaced series of downwardly directed discharge openings, a handle projecting upwardly from said body member, a liquid container mounted upon said body member and supportably connected to said handle, a discharge connection for said container to said conduit provided with a spring seated valve, means for manually opening said valve, an elongated brush and roller support member disposed longitudinally of said body member and comprising laterally spaced side members and connecting end members therefor provided with bearings supportably engaged with said end walls, said support member having lugs at each side of said bearing engaging the end walls of said body member, elongated brushes mounted on said support side members to project downwardly below said body member, and an elongated resiliently compressible cellular distributing roller disposed between said brushes in laterally spaced noncontacting relation to said conduit to receive the discharge therefrom, said roller having journals engaged in said bearings in said support member, said brushes being positioned relative to the roller to extend in brushing contact with a surface over which the roller is supportably translated.

2. An apparatus of the class described comprising an elongated body member of downwardly facing channel section having end walls, said body member having an elongated longitudinally extending liquid discharge conduit therein provided with a spaced series of discharge openings, a handle projecting upwardly from said body member, a liquid container mounted upon said body member and supportably connected to said handle, a discharge connection for said container to said conduit provided with a spring seated valve, means for manually opening said valve, an elongated brush and roller support member disposed longitudinally of said body member and comprising laterally spaced side members and connecting end members therefor supportably engaged with said end walls, elongated brushes mounted on said side members to project downwardly from said body member, and an elongated resiliently compressible cellular distributing roller journaled on said support member end members between said brushes in laterally spaced noncontacting relation thereto and in downwardly spaced noncontacting relation to said conduit to receive the discharge therefrom, said brushes being positioned relative to the roller to extend in brushing contact with a surface over which the roller is supportably translated.

3. An apparatus of the class described comprising a body member adapted to be manipulated over a surface to be treated and having an elongated conduit body member formed integrally therewith and of downwardly facing channel section, said body member also having lugs spaced from the ends of said conduit member, a conduit face-

5

member having a longitudinal series of discharge openings therein and having upwardly facing grooves receiving and sealingly embracing the edges of said conduit member and coacting therewith to provide an elongated liquid distributing conduit, the ends of said conduit face member being engaged with said lugs under compressible stress, a spring clip member mounted on said body member and springably engaged with said conduit face member centrally thereof, a liquid receptacle mounted on said body member in upwardly projecting relation thereto and having a discharge valve connection to said conduit, and a roller mounted on said body member in downwardly spaced non-contacting relation to said conduit to receive the liquid discharged therefrom.

4. An apparatus of the class described comprising a body member adapted to be manipulated over a surface to be treated and having an elongated conduit body member formed integrally therewith and of downwardly facing channel section, a conduit face member having a longitudinal series of discharge openings therein and having upwardly facing grooves receiving and sealingly embracing the edges of said conduit member and coacting therewith to provide an elongated liquid distributing conduit, a spring clip member mounted on said body member and springably engaged with said conduit face member centrally thereof, a liquid receptacle mounted on said body member in upward projecting relation thereto and having a discharge valve connection to said conduit, and a roller mounted on said body member in downwardly spaced non-contacting relation to said conduit to receive the liquid discharged therefrom.

5. An apparatus of the class described comprising an elongated body member provided with an upwardly projecting handle for manual manipulation thereof over a surface to be treated, said body member including an elongated discharge conduit member of downwardly facing channel cross section formed integrally therewith, a conduit face element seatingly engaged with the edge of the walls of said conduit member and having a longitudinal series of discharge openings therein and coacting with said conduit member to provide a discharge extending longitudinally of said body member and transversely of said handle, a liquid receptacle seated upon said body member to project upwardly therefrom in supported relation thereto and to said handle, a discharge connection for said receptacle to said conduit provided with a manual controlled valve, and a distributing roller mounted on said body member in downwardly spaced non-contacting relation to said conduit face element and positioned to receive the discharge therefrom when the apparatus is in upright use position.

6. An apparatus of the class described comprising an elongated body member having an elongated liquid discharge conduit extending longitudinally thereof, a handle connected centrally to said body member and projecting upwardly therefrom, said handle being provided with a grip portion disposed angularly thereto, a liquid container mounted upon said body member and embracing the lower portion of and supportedly connected to said handle, a liquid distributing roller journaled on said body member in downwardly spaced non-contacting relation to said distributing conduit to receive the discharge therefrom, a spring seated valve discharge connection for said liquid container to said liquid distributing conduit, said receptacle being provided with a filling opening at its upper end, said handle having an opening in the side thereof below its said angularly disposed grip portion, a valve actuating rod disposed within said handle and operatively connected to said valve and provided with an angled offset portion at its upper end disposed through said opening in said handle, and a finger piece provided with a body portion cross sectionally conformed to slidably engage the outer side of said handle in overlying relation to said opening therein and constituting a closure therefor, said offset portion of said rod being in engagement with said body portion of

6

said finger piece and acting to retainingly and slidably support it against said handle.

7. An apparatus of the class described comprising an elongated body member having an elongated liquid discharge conduit extending longitudinally thereof, a handle connected centrally to said body member and projecting upwardly therefrom, said handle being provided with a grip portion, a liquid container mounted upon said body member and embracing the lower portion of and supportedly connected to said handle, a liquid distributing roller journaled on said body member in downwardly spaced non-contacting relation to said distributing conduit to receive the discharge therefrom, a spring seated valve discharge connection for said liquid container to said liquid distributing conduit, said handle having an opening in the side thereof below its said grip portion, a valve actuating rod disposed within said handle and operatively connected to said valve, and a finger piece connected to said rod and provided with a body portion cross sectionally conformed to slidably engage the outer side of said handle in overlying relation to said opening therein and constituting a closure therefor.

8. In a device of the class described, a body member constituting a downwardly facing channel housing having spaced end walls, a rectangular frame removably mounted within said housing and carried by said end walls, downwardly extending brushes carried by the sides of said frame, and a cylindrical roller rotatably carried by bearing supports in the ends of said frame and generally parallel to said brushes and between the same, said roller and said brushes being disposed to engage a surface over which the device is translated.

9. The construction of claim 8 and means to retain said frame fixed relative to said body member.

10. In a device of the class described, a rug treating apparatus, an integrally molded body member constituting a downwardly facing channel housing for said rug treating apparatus, said body member having a top with a central raised portion and a second downwardly facing channel providing side walls for a liquid distribution conduit extending longitudinally inside said channel housing, a separate face member independent of the treating apparatus in said housing sealing the bottom of said last named channel and having a series of discharge ports spaced longitudinally therealong for free discharge of liquid upon said treating apparatus in said housing, a liquid receptacle having an integral bottom mounted on said central raised portion of said top of said body member, and a valve controlled passage through the bottom of said receptacle and into said central portion of said distribution conduit.

11. In a device of the class described for treating rugs, a body member, a rug treating roller comprised of a rigid central core and a surface of resilient compressible synthetic sponge material of substantial radial thickness, substantially fixed end bearings of said body member mounting said roller in said member and thereby supporting the member in reciprocal forward and backward movement over a rug, a brush carried by said body member both fore and aft of said roller and having downwardly facing bristles to engage a rug over which said body member is translated, and handle means rigidly secured to said body member for manual translation of the same and of said roller over the rug in pressure roller deforming engagement with the rug to effect treatment of the rug by both said roller and said brush, said roller normally extending downwardly beyond the bristles of said brush and yielding under pressure of said handle to provide for engagement of said brush with the rug, and said rigid handle securement to said body member providing tilting control of said member upon said roller to control the treatment of the rug by the fore and aft portions of said brush.

## References Cited in the file of this patent

## UNITED STATES PATENTS

489,828	Peterson -----	Jan. 10, 1893
1,141,478	Mount -----	June 1, 1915
1,268,963	Gray -----	June 11, 1918
1,461,947	Sporer -----	July 17, 1923

1,550,052
2,154,990
2,336,419
2,633,590
2,696,696
2,882,542
2,935,754

Anderson -----	Aug. 18, 1925
Ombrello -----	Apr. 18, 1939
Pino -----	Dec. 7, 1943
Mitchell -----	Apr. 7, 1953
Ligerman -----	Dec. 14, 1954
Martin -----	Apr. 21, 1959
Abdo et al. -----	May 10, 1960