

(No Model.)

M. THOENI.
BAIL EAR FOR BUCKETS.

No. 483,798.

Patented Oct. 4, 1892.

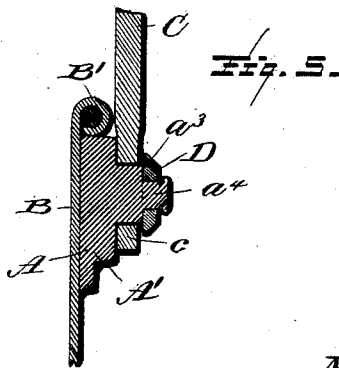
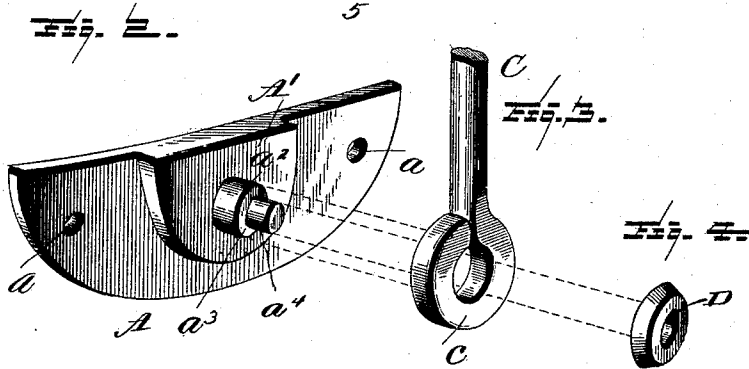
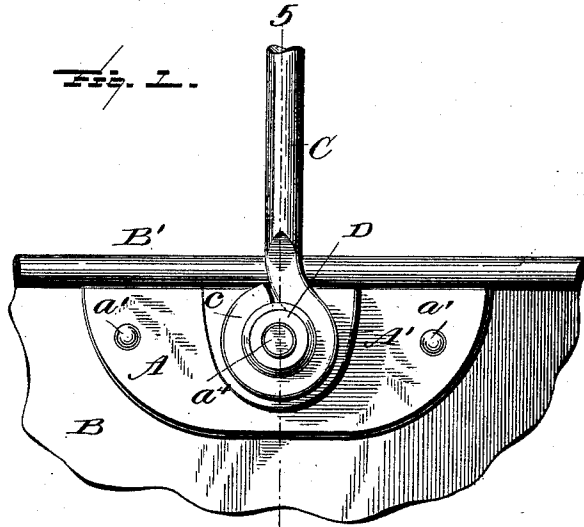

Witnesses:
L. C. Hills.
E. H. Bond.

Inventor:
Martin Thoeni,
By E. B. Stocking
Attorney

UNITED STATES PATENT OFFICE.

MARTIN THOENI, OF MONTICELLO, ASSIGNOR OF ONE-HALF TO JAMES MILNE,
OF SCOTCH GROVE, IOWA.

BAIL-EAR FOR BUCKETS.

SPECIFICATION forming part of Letters Patent No. 483,798, dated October 4, 1892.

Application filed March 11, 1892. Serial No. 424,579. (No model.)

To all whom it may concern:

Be it known that I, MARTIN THOENI, a citizen of the United States, residing at Monticello, in the county of Jones, State of Iowa, have invented certain new and useful Improvements in Bail-Ears for Buckets, of which the following is a specification, reference being had therein to the accompanying drawings.

10 This invention relates to certain new and useful improvements in bail-ears for buckets, pails, and other vessels, and is designed, primarily, for dairy-pails, where strict cleanliness is an essential.

15 It has for its objects, among others, to provide a construction which shall be cheaper, stronger, and less liable to breakage, that will admit of the employment of different kinds of bails to suit the manufacturers, and in which there will be no projecting portion to catch a cloth, thus rendering it much easier to clean. The common ears are objectionable in that they project over or above the top of the vessel enough to afford in themselves a strong leverage for breaking them off if pushed against or subjected to rough usage. Further, they are difficult to keep clean, as they are in the way of the person cleaning them and apt to catch the cloth. My construction avoids these objections. Having a broad base with upper edge shaped to conform to the shape of the vessel makes the latter much stiffer and stronger, especially when placed over the joint in the wire with which such vessels are usually provided. The plate is provided with a lateral projection forming a pivot on which the bail may turn, the projection being formed with a shoulder against which a nut or washer may be held without interfering with the easy movement of the bail.

Other objects and advantages of the invention will hereinafter appear, and the novel features thereof will be specifically defined by the appended claim.

45 The invention is clearly illustrated in the accompanying drawings, which, with the letters of reference marked thereon, form a part of this specification, and in which—

50 Figure 1 is a side elevation of a portion of a vessel with my improvement applied. Figs.

2, 3, and 4 are perspective views of the parts comprising my invention shown separated but in their relative positions. Fig. 2 shows the plate with its projection; Fig. 3, the ear end of the bail, and Fig. 4 the washer. Fig. 5 is a vertical section on the line 5 5 of Fig. 1.

Like letters of reference indicate like parts throughout the several views.

Referring now to the details of the drawings by letter, A designates a base or plate, the inner face of which is shaped to conform to the curvature of the vessel upon which it is to be used and is provided with perforations a for the reception of rivets or other means a' employed in securing it to the vessel B. This plate is provided with a raised portion A' , of sufficient thickness so that when the bail is applied, as shown in Fig. 5, the latter will move in a plane outside the rim B' of the vessel. The plate is further formed with a boss a^2 beyond the raised portion, and upon this boss the loop of the bail C is designed to be loosely sleeved. Beyond the shoulder a^3 , formed at the outer end of this boss, there is a reduced portion a^4 for the reception of a nut or washer. The distance between this shoulder and the outer face of the raised portion should be somewhat greater than the thickness of the loop c of the bail, so that when the nut or washer is securely affixed in position it will bind against the said shoulder and not upon the loop of the bail, and thus the latter is left free to readily turn on its bearing.

D designates the washer or nut.

The plate, its raised portion, boss, and reduced portion are all formed of one integral piece, as shown in Fig. 2.

The plate is applied, as shown in Figs. 1 and 5, with its upper edge against the under side of the rim of the vessel, the bail applied, and then the nut or washer set up. The loop of the bail is preferably flattened, as seen in Fig. 3, but not necessarily so.

The plates may be made of any suitable material and of any desired size and will serve with any required kind of bail.

What I claim is—

A bail-ear comprising a base-plate adapted to fit the body of a vessel and the under sur-

55

60

65

70

75

80

85

90

95

100

face of its top, rim, or body and for attachment to said body and provided with a raised portion for retaining the bail outside of the body of the vessel, a projection forming a
5 pivot for a bail, and a projection for receiving a washer and serving the function of a rivet, the whole constructed of a single piece, substantially as and for the purpose specified.

In testimony whereof I affix my signature in presence of two witnesses.

MARTIN THÖENI.

Witnesses:

B. M. GAYLORD,
FRED KEENAN.