

L. F. ADT.
 EYEGGLASS MOUNTING.
 APPLICATION FILED NOV. 3, 1909.

999,727.

Patented Aug. 8, 1911.

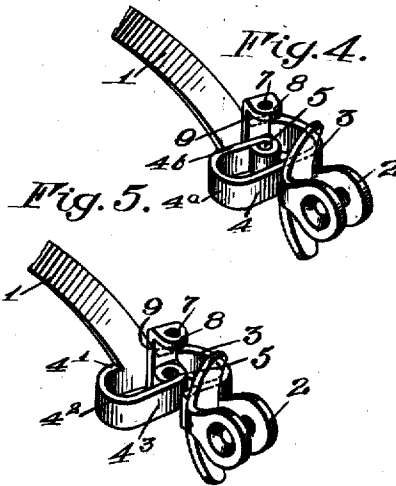
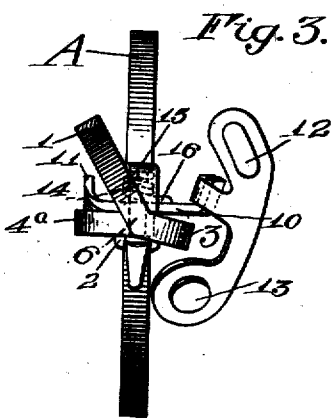
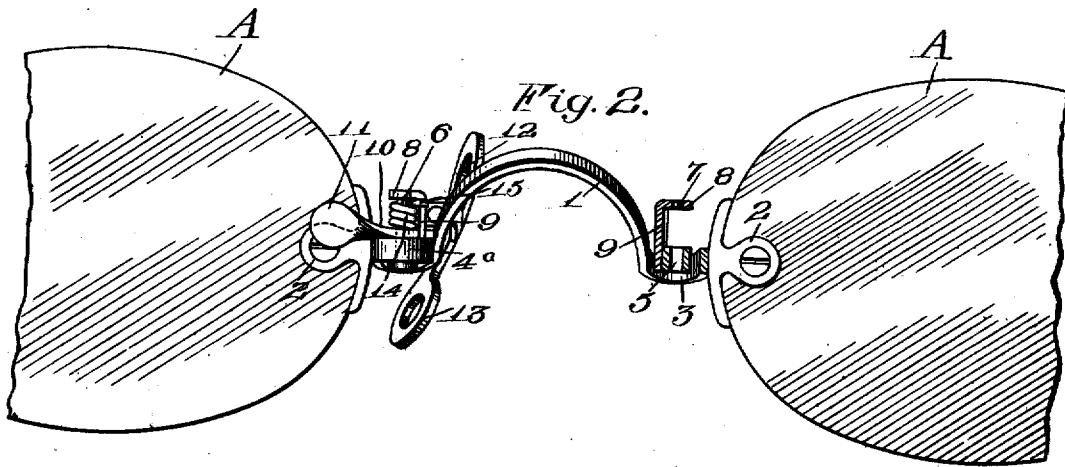
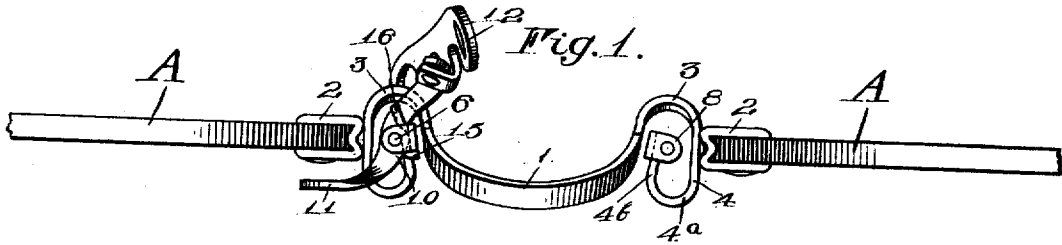

Witnesses
Nelson Copp
J. H. Linn

Inventor
Leo F. Adt
 By *Charles Dick*
 Attorney

UNITED STATES PATENT OFFICE.

LEO F. ADT, OF ALBANY, NEW YORK.

EYEGLASS-MOUNTING.

999,727.

Specification of Letters Patent.

Patented Aug. 8, 1911.

Application filed November 3, 1909. Serial No. 526,093.

To all whom it may concern:

Be it known that I, LEO F. ADT, of Albany, in the county of Albany and State of New York, have invented certain new and useful Improvements in Eyeglass-Mountings; and I do hereby declare the following to be a full, clear, and exact description of the same, reference being had to the accompanying drawings, forming a part of this specification, and to the reference-numerals marked thereon.

The present invention relates to eye-glass mountings of the type employing pivoted guards movable toward the nose under the action of springs or other resilient means and pressed away from the nose by suitable operating finger pieces, an object of this invention being to provide a mounting adapted to be accommodated to the facial characteristics of any person.

To these and other ends the invention consists in certain improvements and combinations of parts, all as will be hereinafter more fully described, the novel features being pointed out in the claims at the end of the specification.

In the drawings: Figure 1 is an enlarged top view of a mounting constructed in accordance with the present improvements and having one of the guards removed. Fig. 2 is a front view of the same mounting showing one of the guards removed and portions of the mounting in section. Fig. 3 is a central vertical section of the mounting. Fig. 4 is a detail view of one end of the mounting, and Fig. 5 is a detail view of an end of another mounting constructed in accordance with this invention.

In the embodiment of the invention illustrated in Figs. 1 to 4, there is employed a support for the lenses A comprising preferably an arched or bridging portion 1, and lens attaching devices or portions 2 connected to the arched or bridging portion 1 by portions 3 which preferably are in the form of rearwardly extending loops made of pliable material, so that the pupillary distance of the lenses may be varied to accommodate the mounting to the pupillary distance of the wearer. The support for the lens also carries adjustable supporting members for the nose guards. These supporting members, each embody arms made of pliable material and preferably formed with return bends. Each arm in this instance extends forwardly at 4 from one of the lens attaching devices,

thence inwardly at 4^a and finally rearwardly at 4^b to a point between one of the lens attaching devices and the proximate end of the bridging portion 1, thus providing a horizontally disposed loop which permits the free end of the arm to be adjusted forwardly and rearwardly, inwardly and outwardly, and upwardly and downwardly.

The nose guards are supported on the free ends of the pliable arms in order that they may partake of the adjustment of the pliable arms so as to accommodate the guards to various types of noses. In the present instance, the inner end of each pliable arm is formed into a sleeve 5 and a pivot pin 6 is introduced upwardly through the lower end of this sleeve so that its upper end will cooperate with screw threads formed on the walls of the opening 7 provided in a horizontal portion 8 that is turned outwardly from the upper end of a bracket 9 carried by the adjustable guard supporting arms 2. Each nose guard may turn on one of the pivot pins 6 and to this end may have the form of a lever 10 provided with a bearing between its ends cooperating with one of the pivot pins 6, its forward end being formed into a finger piece 11 and its rear end carrying a nose engaging member provided with an upper pad 12 and a lower pad 13. The guard levers in this instance operate above the pliable portions 3 which preferably are deflected downwardly, as shown in Fig. 3, to permit said guard levers to be slightly lowered at their rear end for the adjustment of the mounting.

The guards may be moved toward the nose by helically coiled springs 14 which may surround the pivot pins 6 and each have one end 15 bearing against the bracket 9 and the other end 16 engaging the lever of the guard. The brackets 9 serve as stops to limit the inward movements of the nose engaging members of the guards under the action of the springs, this being desirable owing to the fact that the lens attaching devices and the bridging portion 1 have their positions varied with relation to the pivots of the guards.

In the embodiment of the invention shown in Fig. 5 the pliable guard supporting arms are extended from the bridging portion 1 and each comprises a forwardly extending portion 4', an inwardly extending portion 4^a, and a rearwardly extending portion 4^b. With this arrangement, when the lenses of

the mounting are adjusted relatively to the bridging portion 1, the guards do not partake of such adjustment so that it is possible to adjust the guard pivots and the lenses independently of each other.

A mounting constructed in accordance with this invention may be accommodated to the facial characteristics of any wearer, the pupillary distance of the lenses being variable and the positions of the pivots of the guards relatively to the bridging portion being adjustable in all directions to accommodate the mounting to any type of nose. The means for effecting these results are inexpensive to manufacture and simple to manipulate.

I claim as my invention:

1. The combination with a support for the lenses embodying a bridge connecting the latter, of a pliable non resilient member independent of the connection between the bridge and the lenses supported thereby and provided with a return bend and with a bearing, and a nose guard carrying a bearing cooperating with the bearing of the pliable member.

2. The combination with a support for the lenses, of a pliable looped arm supported thereby at one end only having the loop thereof arranged horizontally, a bearing at the free end of the arm, and a nose guard having a bearing cooperating with the bearing on the arm.

3. The combination with a support for the lenses embodying a bridge connecting them, of a pliable non-resilient arm independent of the connection between the bridge and the lenses extending forwardly from the support and rearwardly toward the latter, a bearing on the free end of the pliable arm, and a nose guard having a bearing cooperating with the bearing on the arm.

4. The combination with a support for the lenses embodying a bridge connecting the latter, of two pliable adjusting members supported thereby one of which is provided with a stop and a vertical bearing and the other of which forms a connection between the bridge and the lenses, a nose guard mounted to turn on the bearing and to cooperate with the stop to be limited in its movement by said stop, and a spring for moving the guard toward the stop.

5. The combination with a support for the lenses, of a pliable non resilient guard-supporting looped arm carried thereby and having a free end provided with a bracket extending laterally therefrom said bracket being provided with a turned portion, a pivot pin connecting said turned portion of the bracket with the free end of the arm, and a nose guard mounted to swing on the pivot pin and to cooperate with the bracket.

6. The combination with a support for

the lenses comprising a bridging portion, a lens attaching device and a rearwardly extending pliable non resilient loop connecting the lens attaching device with the bridging portion, of a support for a nose guard comprising a second forwardly extending non resilient pliable loop secured to the support for the lenses embodying a free arm and a vertical bearing carried by the free arm of the loop between the lens attaching device and the proximate end of the bridging portion, a nose guard having a vertical bearing cooperating with the bearing on the pliable arm, and a spring for positioning the guard.

7. The combination with a support for the lenses, of a nose-guard supporting arm connected thereto at one end, the other end being free, said arm being made of pliable non resilient material and having a return bend-horizontally arranged in front of the support for the lenses, a nose guard comprising a pivoted lever mounted to turn on an axis on the arm to one side of the plane of the return bend and to one side of the support and having a finger piece at its forward end and an upper and a lower nose pad at its rear end.

8. The combination with a support for the lenses comprising a bridging portion, a lens attaching device, and a portion connecting the latter with the bridging portion, of a pivot pin carried by the support, a supporting bracket therefor arranged in alignment with the connecting portion transversely of the plane of the lenses, projecting above the connecting portion and having a horizontal portion at its upper end engaged by the pivot pin, and a nose guard embodying a lever turning on the pivot pin and above the connecting portion and having a finger piece at its forward end and upper and lower nose engaging portions at its rear end.

9. The combination with a support for the lenses comprising a bridging portion, lens attaching devices, and rearwardly extending non resilient pliable loops connecting the bridging portion with the lens attaching devices, of pliable arms each extending forwardly from an attaching device, thence inwardly and thence rearwardly to form free arms, the latter being provided each with a vertical bearing, and nose guards each having a bearing mounted to turn in engagement with the bearing on one of the pliable arms.

10. The combination with an eyeglass mounting embodying a bridging portion and a lens attaching portion, of a pliable non resilient loop connecting said portions, a pliable non resilient arm having a free end projecting within the loop and a nose guard turning on the arm.

11. The combination with an eyeglass

mounting embodying a bridging portion and a lens attaching portion, of a pliable, non resilient loop connecting said portions and opening on one side of the mounting
 5 and a pliable non resilient arm extending from said side and having a free end turned back to lie within the loop and a nose guard turning on said free end of the arm.

12. The combination with an eyeglass
 10 mounting embodying a bridging portion and a lens attaching portion, of a pliable non resilient loop connecting said portions, a pliable non resilient arm having a free
 15 end projecting within the loop and a nose guard turning on the arm on an axis arranged in the plane of the lenses.

13. The combination with an eyeglass mounting embodying a bridging portion and a lens attaching portion, of a pliable, non resilient and horizontally disposed loop
 20 connecting said portions and opening on one side of the mounting and a pliable non resilient horizontal arm extending outwardly from said side and thence turned back and
 25 having a free end lying within the loop in the same horizontal plane therewith and a nose guard turning on the free end of the arm to one side of both the arm and loop.

LEO F. ADT.

Witnesses:

EDWARD MURPHY, 2d,
 H. D. BOILER.

Copies of this patent may be obtained for five cents each, by addressing the "Commissioner of Patents, Washington, D. C."