

A. TREPPEAU.  
ELECTRIC HEATING APPARATUS.  
APPLICATION FILED OCT. 25, 1910.

998,269.

Patented July 18, 1911.

2 SHEETS—SHEET 1.

Fig. 1.

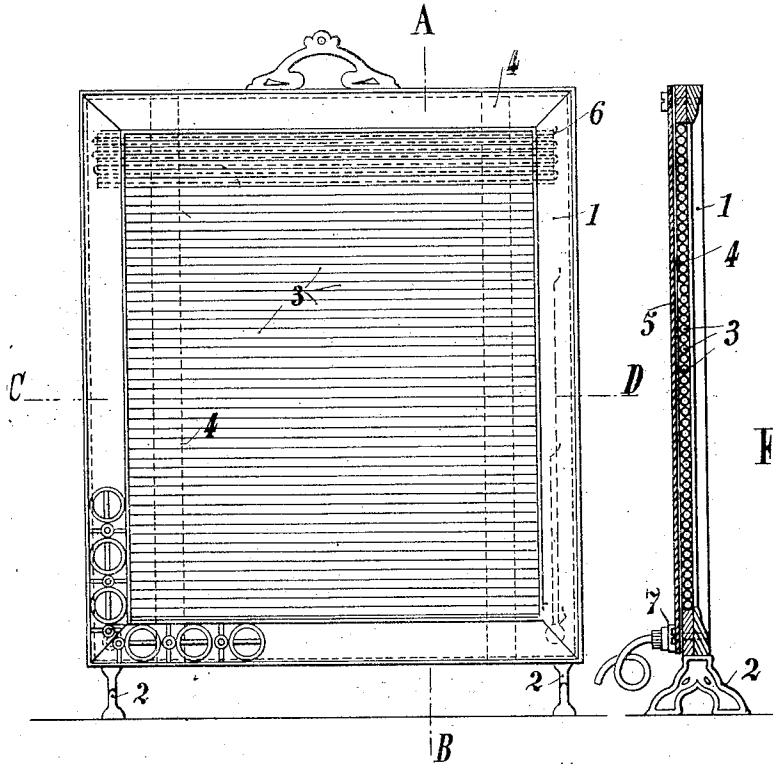
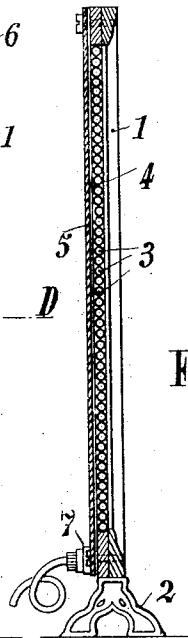

Fig. 2.



B

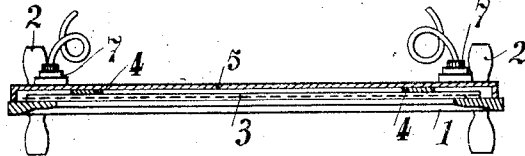

Fig. 3.

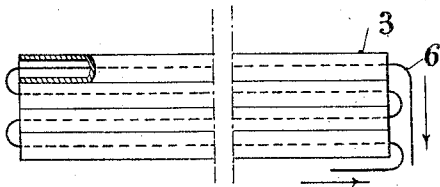

Fig. 4.

Witnesses:  
Anton W. Selander  
E. A. Bond

Inventor:  
A. Treppeau  
by J. Distmar  
Attorney.

A. TREPPEAU.  
 ELECTRIC HEATING APPARATUS.  
 APPLICATION FILED OCT. 25, 1910.

998,269.

Patented July 18, 1911.

2 SHEETS—SHEET 2.

Fig. 5.

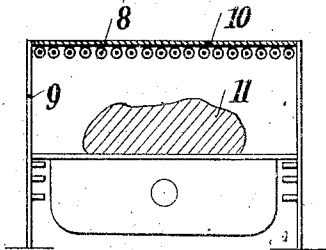

Fig. 6.

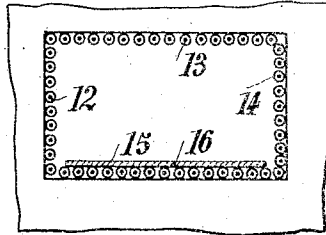

Fig. 7.

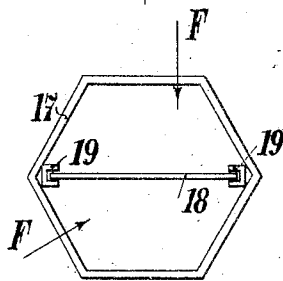
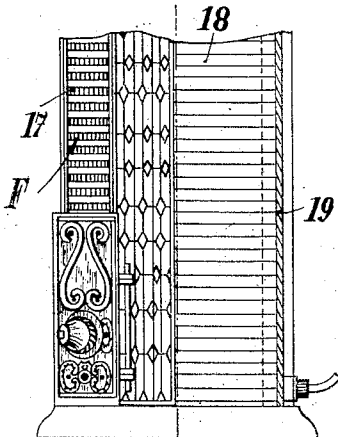

Fig. 8.

Witnesses:  
 Anton W. Selander.  
 E. A. Bond

Inventor:  
 A. Treppeau  
 by F. Dillman  
 Attorney.

# UNITED STATES PATENT OFFICE.

ALEXANDRE TREPRAU, OF JOINVILLE-LE-PONT, FRANCE.

ELECTRIC HEATING APPARATUS.

998,269.

Specification of Letters Patent. Patented July 18, 1911.

Application filed October 25, 1910. Serial No. 589,067.

To all whom it may concern:

Be it known that I, ALEXANDRE TREPRAU, citizen of the French Republic, residing at Joinville-le-Pont, Seine, France, have invented certain new and useful Improvements in or Relating to Electric Heating Apparatus, of which the following is a specification, reference being had therein to the accompanying drawing.

10 Electric radiators as at present known have the following disadvantages: Owing to the great mass of material by which they are constituted, which mass has to be first heated, they begin to give out heat only after a comparatively long time from the moment at which they are switched into the electric circuit; and also they consume a great quantity of electric energy and their cost price is very high. Moreover, some of them, owing to the nature of the insulating material employed evolve a disagreeable smell. Others again in which special lamps are used, have only a very small heating surface.

25 This invention however relates to various construction of electric radiators which are free from the above mentioned disadvantages. They chiefly comprise glass tubes open at both ends, through which passes a wire which is thus in the open air, without interposition of any other insulating material. These apparatus instantaneously disengage heat as soon as the circuit is closed, they consume very little electrical energy, are cheap, do not cause any unpleasant smell and have a considerable heating surface. They are characterized, moreover, by simplicity of manufacture and of construction of their elements.

40 Several constructions of electric radiators according to this invention are illustrated by way of example in the accompanying drawings, in which:

45 Figures 1 to 4 show a radiator forming a kind of screen. Fig. 1 is an elevation of the same, Figs. 2 and 3 vertical and horizontal sections respectively on lines A—B and C—D respectively of Fig. 1, while Fig. 4 shows separately a certain number of elements arranged side by side. Figs. 5 and 6 are modified constructions. Figs. 7 and 8 show the application of the device to an existing heating apparatus, the casing of which can be utilized.

55 The radiator shown in Figs. 1 to 4 is chiefly constituted by a frame 1 ornamented

to a greater or less extent and supported by legs 2. Behind the frame in question are arranged superposed glass tubes 3 held by means of two metal bands 4. A metal plate 5 is placed behind the bands in question and secured to the frame 1 by means of screws, bolts, rivets, etc. A wire 6 passes through the tubes 3, and its ends terminate at two terminals 7 by means of which the apparatus can be put into circuit. As soon as the current begins to pass, the wires are heated and thus produce a certain heating of the glass tubes, and owing to their great surface, a great quantity of heat is disengaged.

The apparatus could be used either for a continuous current circuit or for an alternating current circuit. The tubes, instead of being superposed, could be arranged next to each other or in any other suitable manner, and the apparatus can be used in any desired position, whether vertical, horizontal or inclined. The tubes could be vertical or inclined in a vertical plane. In that way there would take place naturally in their interior a circulation of air which would render the heating more quick. Moreover it is obvious that dimensions, shape and appearance of the radiator may be varied as desired. This heating apparatus is also suitable for cooking meat, and for that purpose several apparatus of various shapes have been constructed. In some of them, electric roasting apparatus, Fig. 5, a series of glass tubes 8 is placed horizontally at the top of the apparatus 9, but inside it. A cast iron plate 10 arranged above prevents the heat from escaping. The joint is of course placed below at 11 like in existing gas roasting devices. In other apparatus (electric stoves), series of tubes and of circuits are arranged in the four inner faces 12, 13, 14, 15 of the stove, as shown diagrammatically in Fig. 6. These circuits being absolutely independent of each other, it is possible to regulate the stove in a very easy and convenient manner. In this case, it is necessary to place on the bottom portion a sheet metal plate 16 for supporting the dishes and preventing the sauce or gravy from overflowing on the glass tubes of the series 15. Ordinary glass tubes could be used for the apparatus but it is preferable to use a special glass which will stand splashes of liquid without breaking.

The devices described in the foregoing as applications of the subject of the invention,

could also be adapted so as to combine them with any existing heating apparatus, the source of heating being that given by the electric current in place of the fuel generally used in the said apparatus, which can be stoves, chafing dishes, portable fire places, etc.

Figs. 7 and 8 show by way of example the arrangement of a net-work of radiating elements or glass tubes placed into a casing of the type of stoves generally heated by means of coke or coals in which the inner parts, namely the furnace, etc., are done away with. These various figures are merely diagrams. The casing 17 in question has for instance a hexagonal shape but it could be also round or of any other shape, and is supported by suitable legs. The elements or glass tubes 18 are arranged above each other in fixed guides 19. The heating wires may be fixed in the glass tubes in any suitable or well-known way. It must however be pointed out that in this construction there is a circulation of air in the direction of the arrows F through the perforated walls of the casing 17, the cold air heated by contact with the tubes 18 escaping while hot from the apparatus through its upper portion provided with a perforated lid. Under those conditions the vertical walls 17 are not heated by the radiating tubes, and the heating of the air of a room is effected exclusively by circulation.

Having now particularly described and

ascertained the nature of my said invention and in what manner the same is to be performed, I declare that what I claim is:

1. An electric radiator embodying a series of glass tubes open at both ends, a frame in which said tubes are held, a resistance wire passed through said tubes permitting a free circulation of air through said tubes, the latter being in open communication with the atmosphere.

2. An electric radiator comprising a series of glass tubes open at both ends, a frame in which said tubes are mounted, a resistance wire passed circuitously through said tubes and out of contact with the walls thereof permitting a free circulation of air through the tubes and terminals outside said frame.

3. An electric radiator comprising a metallic plate, a frame mounted thereon, glass tubes mounted in said frame, bands securing said tubes in position, said tubes being open at both ends, a resistance wire passed through said tubes circuitously and alternately in opposite directions, and terminals for said wire outside the frame.

In testimony whereof I affix my signature in the presence of two witnesses.

ALEXANDRE TREPPEAU.

Witnesses:

H. C. COXE,  
VICTOR TRÉVOR.