



US00D378283S

# United States Patent [19]

[11] Patent Number: **Des. 378,283**

Diehl

[45] Date of Patent: **\*\*Mar. 4, 1997**

## [54] COMPRESSED GAS REGULATOR

[75] Inventor: **Gregory W. Diehl**, Florence, S.C.

[73] Assignee: **The ESAB Group, Inc.**, Florence, S.C.

[\*\*] Term: **14 Years**

[21] Appl. No.: **47,361**

[22] Filed: **Dec. 1, 1995**

[52] U.S. Cl. .... **D10/85**

[58] Field of Search ..... D10/85; 73/431, 73/714; 137/69, 71, 505.42, 505.11, 557, 559, 906; 169/58, 70

## [56] References Cited

### U.S. PATENT DOCUMENTS

856,989	6/1907	Schultz, Jr. ....	137/505.42 X
2,595,156	4/1952	Matasovic .....	73/714
2,768,643	10/1956	Acomb .	
2,918,081	12/1959	Laver, Jr. ....	137/505.11
3,926,208	12/1975	Hoffman et al. .	
4,915,127	4/1990	Werley .....	137/505.42
5,022,435	6/1991	Jaw-Shiunn .	

Primary Examiner—Antoine Duval Davis

Attorney, Agent, or Firm—Bell, Seltzer, Park & Gibson, P.A.

## [57] CLAIM

The ornamental design for a compressed gas regulator, as shown and described.

## DESCRIPTION

FIG. 1 is a perspective view of a compressed gas regulator which embodies the design of the present invention; FIG. 2 is a side elevation view of the regulator; FIG. 3 is a top plan view of the regulator; FIG. 4 is a front elevation view of the regulator, rotated 90° from the orientation shown in FIGS. 1 and 2; FIG. 5 is a side elevation view of the regulator and illustrating the side opposite that shown in FIG. 2, and rotated 180° from the orientation shown in FIGS. 1 and 2;

FIG. 6 is a rear elevation view of the regulator, rotated 180° from the orientation shown in FIGS. 1 and 2;

FIG. 7 is a bottom plan view of the regulator;

FIG. 8 is a perspective view of a compressed gas regulator which embodies the design of the present invention;

FIG. 9 is a side elevation view of the compressed gas regulator;

FIG. 10 is a top plan view of the compressed gas regulator;

FIG. 11 is a front elevation view of the compressed gas regulator, rotated 90 degrees from the orientation shown in FIGS. 8 and 9;

FIG. 12 is a side elevation view of the compressed gas regulator illustrating the side opposite that shown in FIG. 9, and rotated 180 degrees from the orientation shown in FIGS. 8 and 9;

FIG. 13 is a rear elevation view of the compressed gas regulator, rotated 180 degrees from the orientation shown in FIGS. 8 and 9;

FIG. 14 is a bottom plan view of the compressed gas regulator;

FIG. 15 is a perspective view of a compressed gas regulator which embodies the design of the present invention;

FIG. 16 is a side elevation view of the compressed gas regulator;

FIG. 17 is a top plan view of the compressed gas regulator;

FIG. 18 is a front elevation view of the compressed gas regulator, rotated 90 degrees from the orientation shown in FIGS. 15 and 16;

FIG. 19 is a side elevation view of the compressed gas regulator illustrating the side opposite that shown in FIG. 16, and rotated 180 degrees from the orientation shown in FIGS. 15 and 16;

FIG. 20 is a rear elevation view of the compressed gas regulator, rotated 180 degrees from the orientation shown in FIGS. 15 and 16; and,

FIG. 21 is a bottom plan view of the compressed gas regulator.

1 Claim, 6 Drawing Sheets

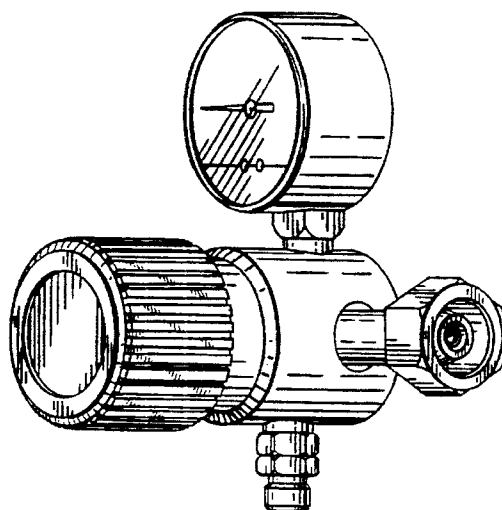

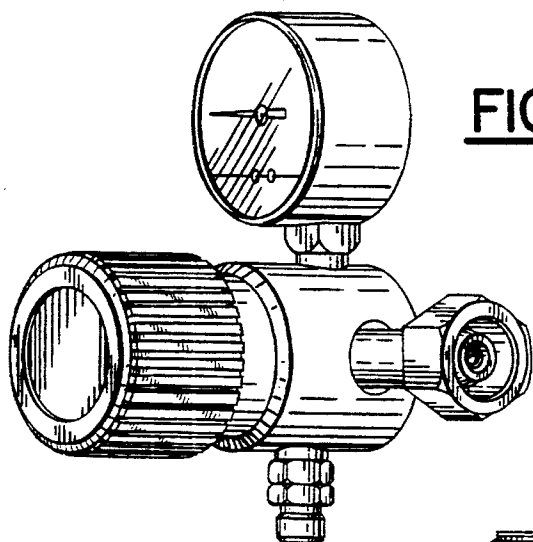

FIG. 1.

FIG. 2.

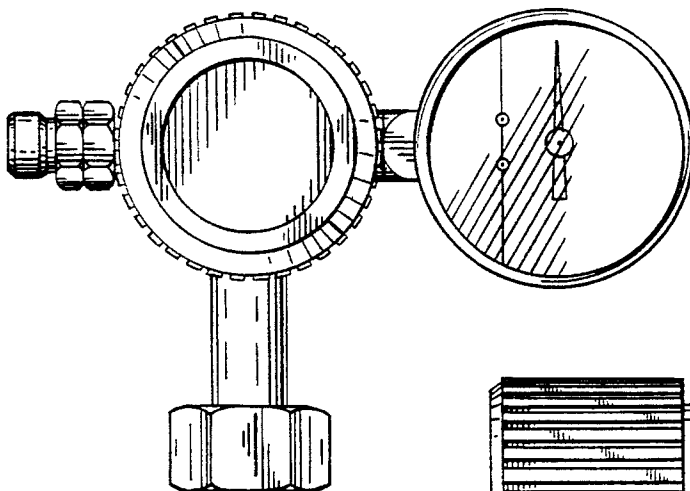
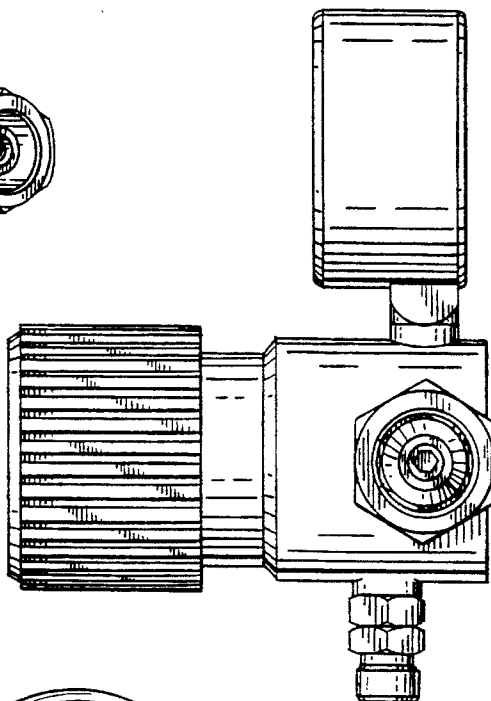

FIG. 4.

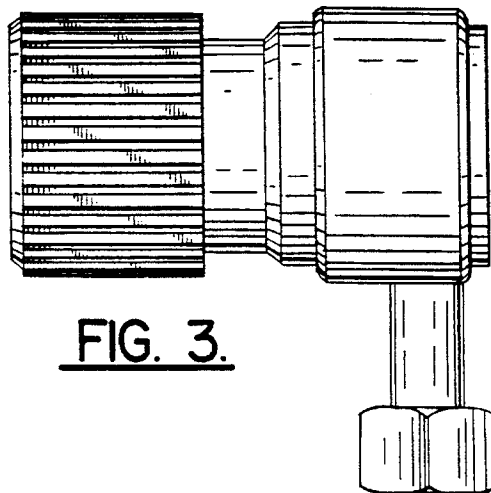
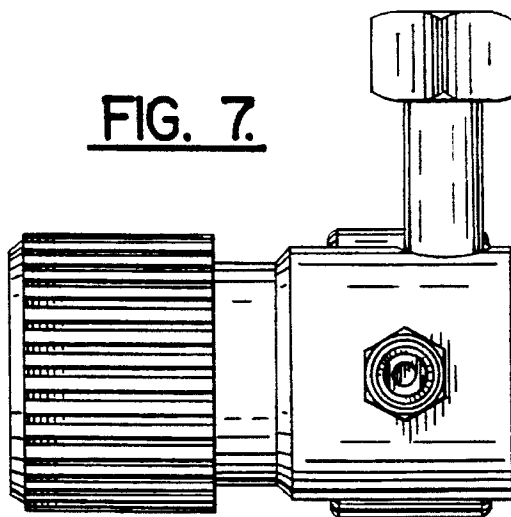
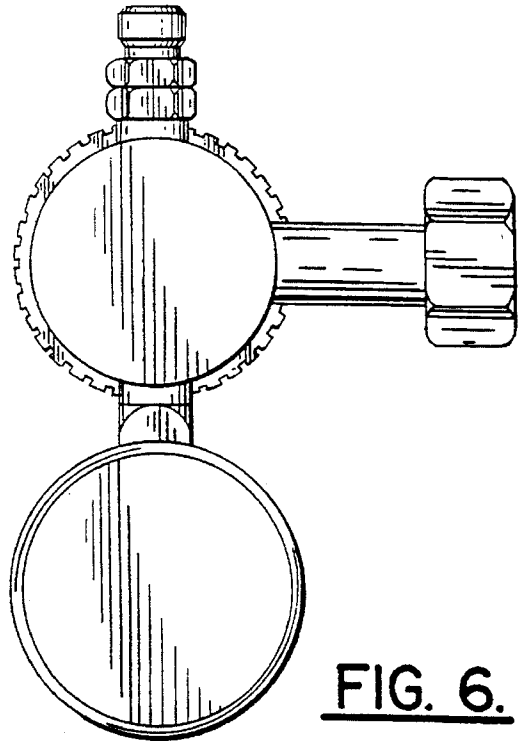
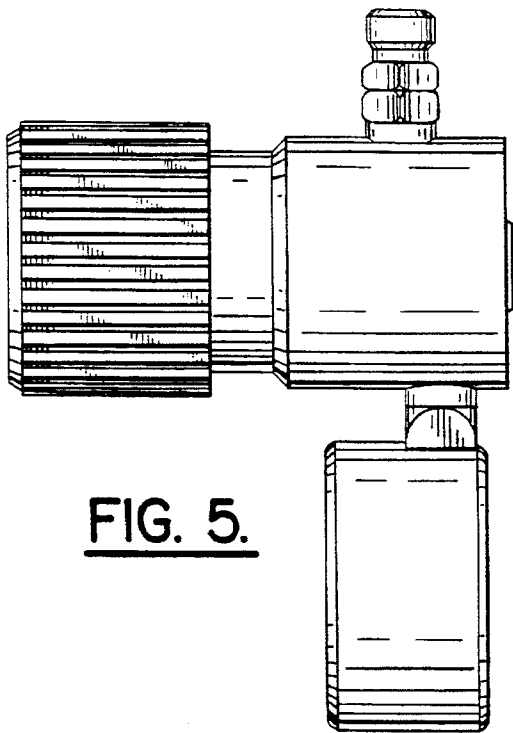

FIG. 3.



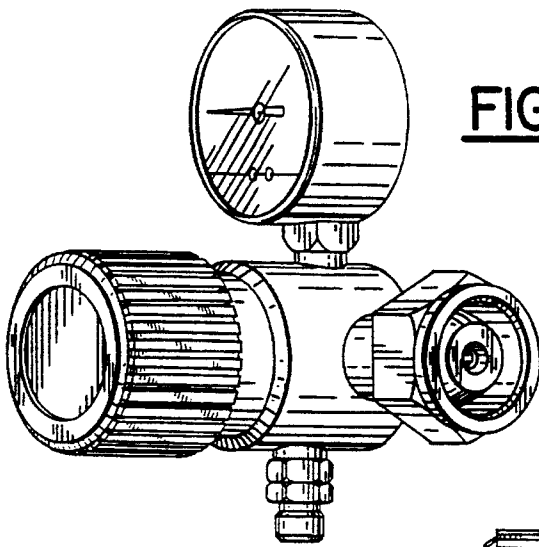

FIG. 8.

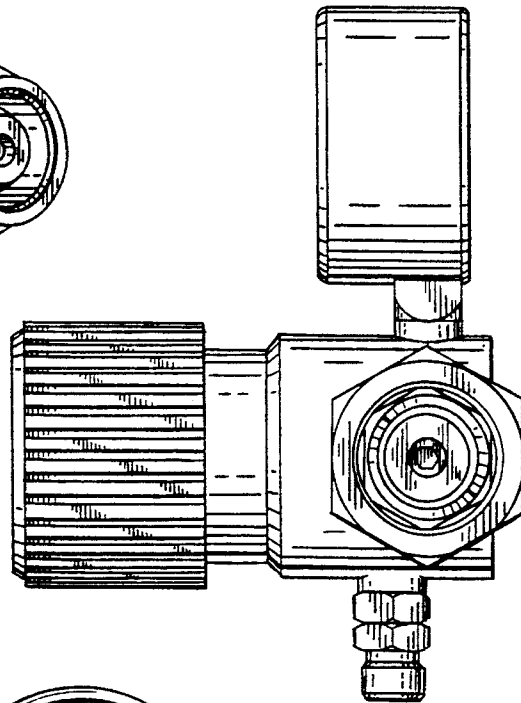

FIG. 9.

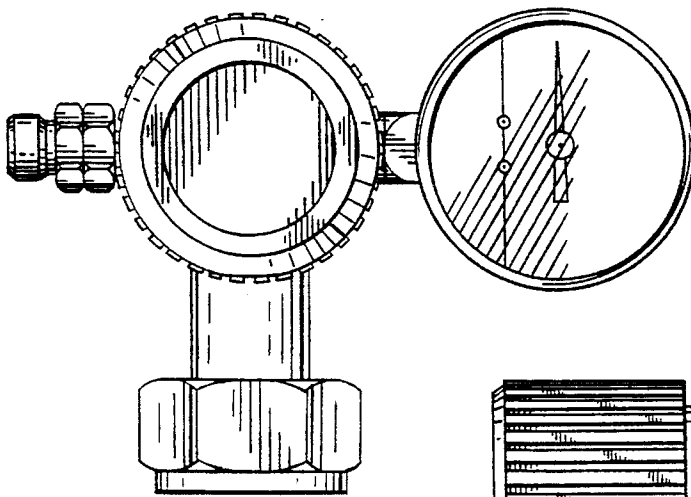

FIG. 11.

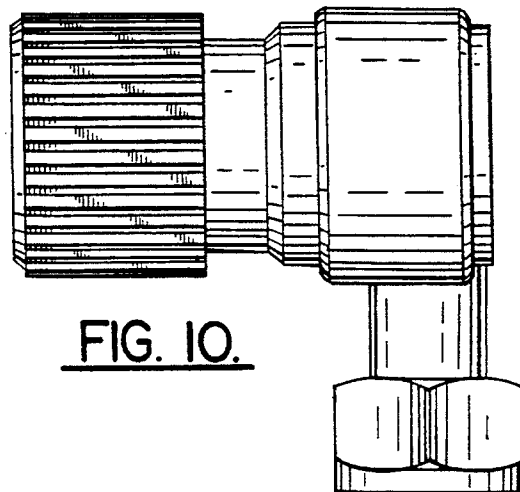
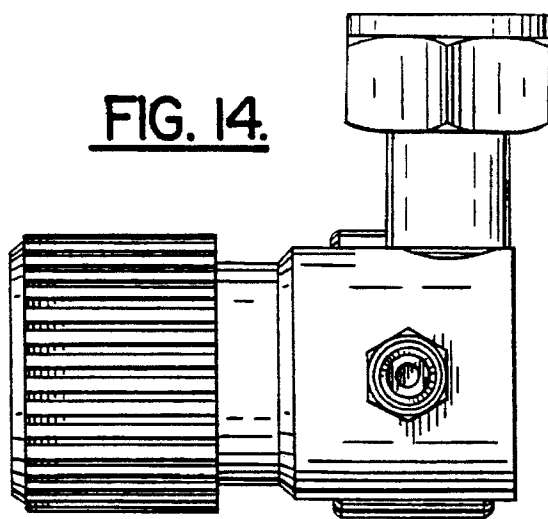
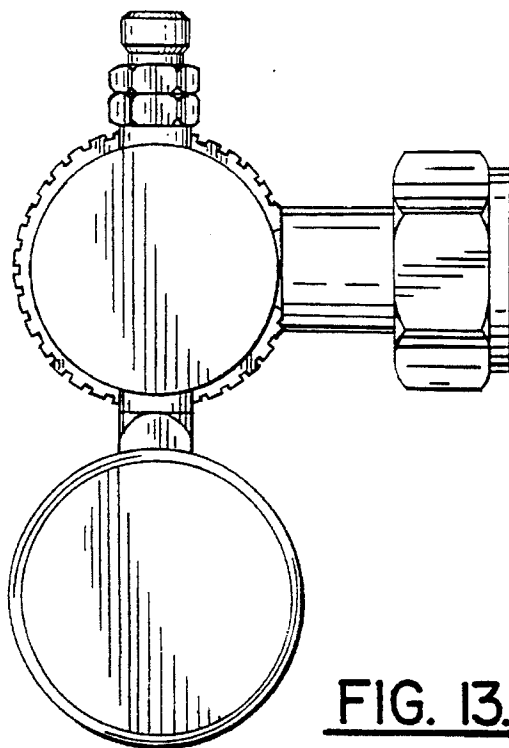
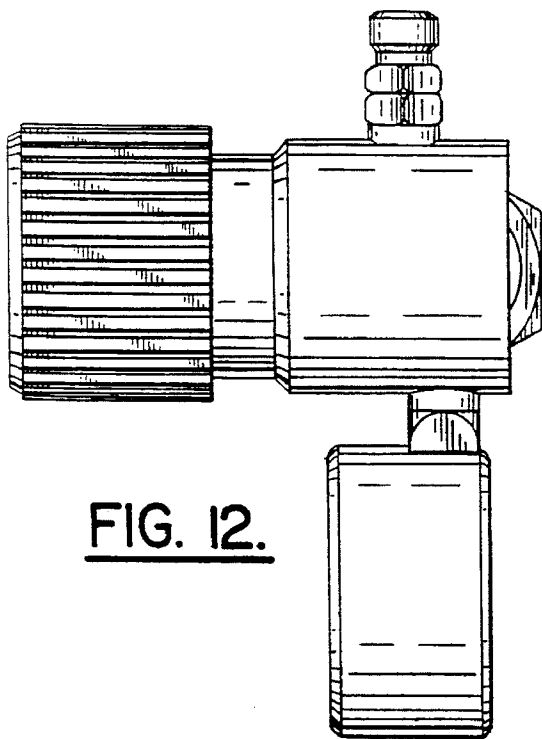

FIG. 10.



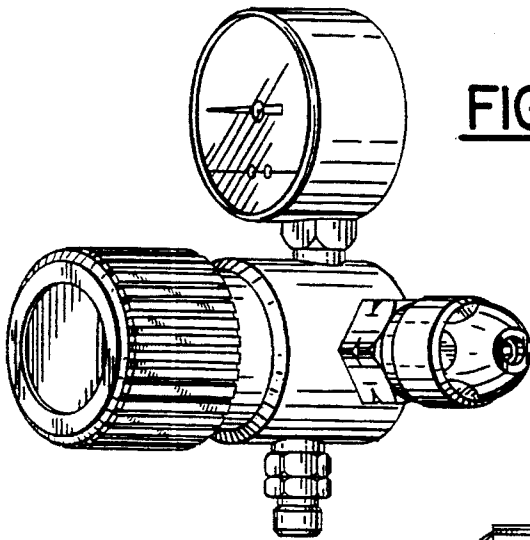

FIG. 15.

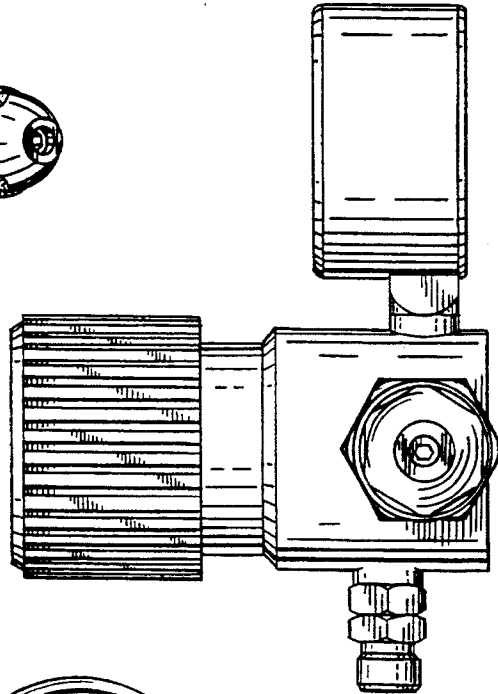

FIG. 16.

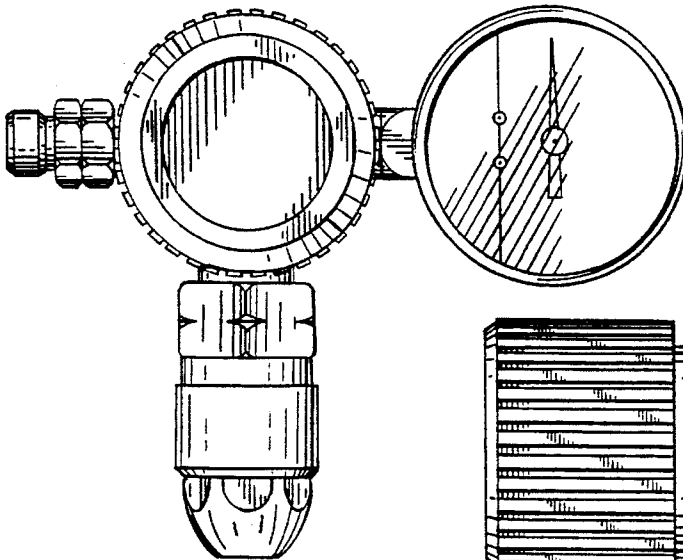

FIG. 18.

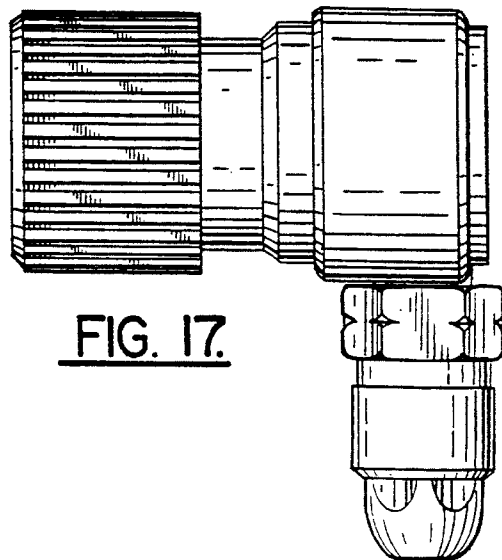

FIG. 17.

