



- (51) International Patent Classification:
H04L 5/00 (2006.01) H04W 88/04 (2009.01)
H04W 72/12 (2009.01)
- (21) International Application Number:
PCT/US2020/046462
- (22) International Filing Date:
14 August 2020 (14.08.2020)
- (25) Filing Language: English
- (26) Publication Language: English
- (30) Priority Data:
62/887,333 15 August 2019 (15.08.2019) US
- (72) Inventors; and
- (71) Applicants: **HUI, Bing** [CN/US]; 11091 Sunset Hills Road, Suite #510, Reston, Virginia 20190 (US). **DINAN, Esmael** [US/US]; 11091 Sunset Hills Road, Suite #510, Reston, Virginia 20190 (US). **ZHOU, Hua** [CN/US]; 11091 Sunset Hills Road, Suite #510, Reston, Virginia 20190 (US). **CHAE, Hyukjin** [KR/US]; 11091 Sunset Hills Road, Suite #510, Reston, Virginia 20190 (US). **YI, Yunjung** [KR/US];

11091 Sunset Hills Road, Suite #510, Reston, Virginia 20190 (US).

(74) Agent: **NASABZADEH, Kavon** et al.; 11091 Sunset Hills Road, Suite 510, Reston, Virginia 20190 (US).

(81) Designated States (unless otherwise indicated, for every kind of national protection available): AE, AG, AL, AM, AO, AT, AU, AZ, BA, BB, BG, BH, BN, BR, BW, BY, BZ, CA, CH, CL, CN, CO, CR, CU, CZ, DE, DJ, DK, DM, DO, DZ, EC, EE, EG, ES, FI, GB, GD, GE, GH, GM, GT, HN, HR, HU, ID, IL, IN, IR, IS, IT, JO, JP, KE, KG, KH, KN, KP, KR, KW, KZ, LA, LC, LK, LR, LS, LU, LY, MA, MD, ME, MG, MK, MN, MW, MX, MY, MZ, NA, NG, NI, NO, NZ, OM, PA, PE, PG, PH, PL, PT, QA, RO, RS, RU, RW, SA, SC, SD, SE, SG, SK, SL, ST, SV, SY, TH, TJ, TM, TN, TR, TT, TZ, UA, UG, US, UZ, VC, VN, WS, ZA, ZM, ZW.

(84) Designated States (unless otherwise indicated, for every kind of regional protection available): ARIPO (BW, GH, GM, KE, LR, LS, MW, MZ, NA, RW, SD, SL, ST, SZ, TZ, UG, ZM, ZW), Eurasian (AM, AZ, BY, KG, KZ, RU, TJ, TM), European (AL, AT, BE, BG, CH, CY, CZ, DE, DK, EE, ES, FI, FR, GB, GR, HR, HU, IE, IS, IT, LT, LU, LV,

(54) Title: PREEMPTION INDICATION AND RADIO RESOURCE SELECTION FOR SIDELINK TRANSMISSION

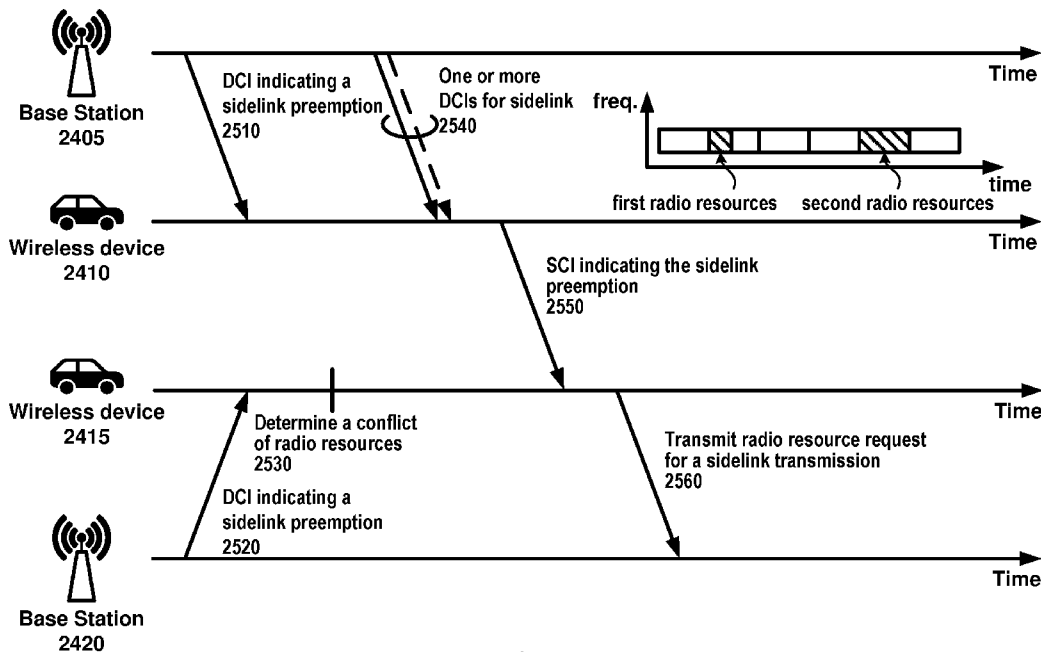

FIG. 25

(57) Abstract: A wireless device receives one or more downlink control information (DCI) indicating a sidelink preemption. Sidelink control information (SCI) is transmitted, via first radio resources, in response to the sidelink preemption. The SCI indicates second radio resources. A sidelink transmission is transmitted via the second radio resources.



MC, MK, MT, NL, NO, PL, PT, RO, RS, SE, SI, SK, SM,
TR), OAPI (BF, BJ, CF, CG, CI, CM, GA, GN, GQ, GW,
KM, ML, MR, NE, SN, TD, TG).

Published:

- *with international search report (Art. 21(3))*
- *before the expiration of the time limit for amending the claims and to be republished in the event of receipt of amendments (Rule 48.2(h))*

TITLE**PREEMPTION INDICATION AND RADIO RESOURCE SELECTION FOR
SIDELINK TRANSMISSION****CROSS-REFERENCE TO RELATED APPLICATIONS**

[0001] This application claims the benefit of U.S. Provisional Application No. 62/887,333, filed August 15, 2019, which is hereby incorporated by reference in its entirety.

BRIEF DESCRIPTION OF THE DRAWINGS

- [0002] Examples of several of the various embodiments of the present disclosure are described herein with reference to the drawings.
- [0003] FIG. 1A and FIG. 1B illustrate example mobile communication networks in which embodiments of the present disclosure may be implemented.
- [0004] FIG. 2A and FIG. 2B respectively illustrate a New Radio (NR) user plane and control plane protocol stack.
- [0005] FIG. 3 illustrates an example of services provided between protocol layers of the NR user plane protocol stack of FIG. 2A.
- [0006] FIG. 4A illustrates an example downlink data flow through the NR user plane protocol stack of FIG. 2A.
- [0007] FIG. 4B illustrates an example format of a MAC subheader in a MAC PDU.
- [0008] FIG. 5A and FIG. 5B respectively illustrate a mapping between logical channels, transport channels, and physical channels for the downlink and uplink.
- [0009] FIG. 6 is an example diagram showing RRC state transitions of a UE.
- [0010] FIG. 7 illustrates an example configuration of an NR frame into which OFDM symbols are grouped.
- [0011] FIG. 8 illustrates an example configuration of a slot in the time and frequency domain for an NR carrier.
- [0012] FIG. 9 illustrates an example of bandwidth adaptation using three configured BWPs for an NR carrier.
- [0013] FIG. 10A illustrates three carrier aggregation configurations with two component carriers.
- [0014] FIG. 10B illustrates an example of how aggregated cells may be configured into one or more PUCCH groups.
- [0015] FIG. 11A illustrates an example of an SS/PBCH block structure and location.
- [0016] FIG. 11B illustrates an example of CSI-RSs that are mapped in the time and frequency domains.

- [0017] FIG. 12A and FIG. 12B respectively illustrate examples of three downlink and uplink beam management procedures.
- [0018] FIG. 13A, FIG. 13B, and FIG. 13C respectively illustrate a four-step contention-based random access procedure, a two-step contention-free random access procedure, and another two-step random access procedure.
- [0019] FIG. 14A illustrates an example of CORESET configurations for a bandwidth part.
- [0020] FIG. 14B illustrates an example of a CCE-to-REG mapping for DCI transmission on a CORESET and PDCCH processing.
- [0021] FIG. 15 illustrates an example of a wireless device in communication with a base station.
- [0022] FIG. 16A, FIG. 16B, FIG. 16C, and FIG. 16D illustrate example structures for uplink and downlink transmission.
- [0023] FIG. 17A and FIG. 17B are examples of an in-coverage D2D communication as per an aspect of an embodiment of the present disclosure.
- [0024] FIG. 18 is a diagram of an example partial-coverage D2D communication as per an aspect of an embodiment of the present disclosure.
- [0025] FIG. 19 is a diagram of an example out-of-coverage D2D communication as per an aspect of an embodiment of the present disclosure.
- [0026] FIG. 20 is a diagram of an example D2D communication as per an aspect of an embodiment of the present disclosure.
- [0027] FIG. 21 is a diagram of an example mapping between a resource pool (RP) and a zone as per an aspect of an embodiment of the present disclosure.
- [0028] FIG. 22 is a diagram of an example vehicle-to-everything (V2X) communications as per an aspect of an embodiment of the present disclosure.
- [0029] FIG. 23 illustrates a sidelink preemption following uplink preemption as per an aspect of an example embodiment of the present disclosure.
- [0030] FIG. 24 illustrates a sidelink preemption as per an aspect of an example embodiment of the present disclosure.
- [0031] FIG. 25 illustrates a sidelink preemption as per an aspect of an example embodiment of the present disclosure.
- [0032] FIG. 26 illustrates a sidelink preemption as per an aspect of an example embodiment of the present disclosure.
- [0033] FIG. 27 illustrates a sidelink preemption as per an aspect of an example embodiment of the present disclosure.

- [0034] FIG. 28 illustrates a sidelink preemption as per an aspect of an example embodiment of the present disclosure.
- [0035] FIG. 29 illustrates a sidelink preemption as per an aspect of an example embodiment of the present disclosure.
- [0036] FIG. 30 illustrates a sidelink preemption as per an aspect of an example embodiment of the present disclosure.
- [0037] FIG. 31 illustrates a sidelink preemption as per an aspect of an example embodiment of the present disclosure.
- [0038] FIG. 32 illustrates a sidelink preemption as per an aspect of an example embodiment of the present disclosure.
- [0039] FIG. 33 illustrates a sidelink preemption as per an aspect of an example embodiment of the present disclosure.
- [0040] FIG. 34 illustrates a sidelink preemption as per an aspect of an example embodiment of the present disclosure.
- [0041] FIG. 35 illustrates a sidelink preemption as per an aspect of an example embodiment of the present disclosure.
- [0042] FIG. 36 illustrates a wireless device procedure as per an aspect of an example embodiment of the present disclosure.
- [0043] FIG. 37 illustrates a wireless device procedure as per an aspect of an example embodiment of the present disclosure.
- [0044] FIG. 38 illustrates a wireless device procedure as per an aspect of an example embodiment of the present disclosure.
- [0045] FIG. 39 illustrates a wireless device procedure as per an aspect of an example embodiment of the present disclosure.
- [0046] FIG. 40 illustrates a group common DCI as per an aspect of an example embodiment of the present disclosure.
- [0047] FIG. 41 illustrates a SCI as per an aspect of an example embodiment of the present disclosure.
- [0048] FIG. 42 is a flow diagram that illustrates an aspect of an example embodiment of the present disclosure.
- [0049] FIG. 43 is a flow diagram that illustrates an aspect of an example embodiment of the present disclosure.
- [0050] FIG. 44 is a flow diagram that illustrates an aspect of an example embodiment of the present disclosure.

[0051] FIG. 45 is a flow diagram that illustrates an aspect of an example embodiment of the present disclosure.

[0052] FIG. 46 is a flow diagram that illustrates an aspect of an example embodiment of the present disclosure.

DETAILED DESCRIPTION

[0053] In the present disclosure, various embodiments are presented as examples of how the disclosed techniques may be implemented and/or how the disclosed techniques may be practiced in environments and scenarios. It will be apparent to persons skilled in the relevant art that various changes in form and detail can be made therein without departing from the scope. In fact, after reading the description, it will be apparent to one skilled in the relevant art how to implement alternative embodiments. The present embodiments should not be limited by any of the described exemplary embodiments. The embodiments of the present disclosure will be described with reference to the accompanying drawings. Limitations, features, and/or elements from the disclosed example embodiments may be combined to create further embodiments within the scope of the disclosure. Any figures which highlight the functionality and advantages, are presented for example purposes only. The disclosed architecture is sufficiently flexible and configurable, such that it may be utilized in ways other than that shown. For example, the actions listed in any flowchart may be re-ordered or only optionally used in some embodiments.

[0054] Embodiments may be configured to operate as needed. The disclosed mechanism may be performed when certain criteria are met, for example, in a wireless device, a base station, a radio environment, a network, a combination of the above, and/or the like. Example criteria may be based, at least in part, on for example, wireless device or network node configurations, traffic load, initial system set up, packet sizes, traffic characteristics, a combination of the above, and/or the like. When the one or more criteria are met, various example embodiments may be applied. Therefore, it may be possible to implement example embodiments that selectively implement disclosed protocols.

[0055] A base station may communicate with a mix of wireless devices. Wireless devices and/or base stations may support multiple technologies, and/or multiple releases of the same technology. Wireless devices may have some specific capability(ies) depending on wireless device category and/or capability(ies). When this disclosure refers to a base station communicating with a plurality of wireless devices, this disclosure may refer to a subset of the total wireless devices in a coverage area. This disclosure may refer to, for example, a plurality of wireless devices of a given LTE or 5G release with a given capability and in a given sector of the base station. The plurality of wireless devices in this disclosure may refer

to a selected plurality of wireless devices, and/or a subset of total wireless devices in a coverage area which perform according to disclosed methods, and/or the like. There may be a plurality of base stations or a plurality of wireless devices in a coverage area that may not comply with the disclosed methods, for example, those wireless devices or base stations may perform based on older releases of LTE or 5G technology.

[0056] In this disclosure, “a” and “an” and similar phrases are to be interpreted as “at least one” and “one or more.” Similarly, any term that ends with the suffix “(s)” is to be interpreted as “at least one” and “one or more.” In this disclosure, the term “may” is to be interpreted as “may, for example.” In other words, the term “may” is indicative that the phrase following the term “may” is an example of one of a multitude of suitable possibilities that may, or may not, be employed by one or more of the various embodiments. The terms “comprises” and “consists of”, as used herein, enumerate one or more components of the element being described. The term “comprises” is interchangeable with “includes” and does not exclude unenumerated components from being included in the element being described. By contrast, “consists of” provides a complete enumeration of the one or more components of the element being described. The term “based on”, as used herein, should be interpreted as “based at least in part on” rather than, for example, “based solely on”. The term “and/or” as used herein represents any possible combination of enumerated elements. For example, “A, B, and/or C” may represent A; B; C; A and B; A and C; B and C; or A, B, and C.

[0057] If A and B are sets and every element of A is an element of B, A is called a subset of B. In this specification, only non-empty sets and subsets are considered. For example, possible subsets of $B = \{\text{cell1}, \text{cell2}\}$ are: $\{\text{cell1}\}$, $\{\text{cell2}\}$, and $\{\text{cell1}, \text{cell2}\}$. The phrase “based on” (or equally “based at least on”) is indicative that the phrase following the term “based on” is an example of one of a multitude of suitable possibilities that may, or may not, be employed to one or more of the various embodiments. The phrase “in response to” (or equally “in response at least to”) is indicative that the phrase following the phrase “in response to” is an example of one of a multitude of suitable possibilities that may, or may not, be employed to one or more of the various embodiments. The phrase “depending on” (or equally “depending at least to”) is indicative that the phrase following the phrase “depending on” is an example of one of a multitude of suitable possibilities that may, or may not, be employed to one or more of the various embodiments. The phrase “employing/using” (or equally “employing/using at least”) is indicative that the phrase following the phrase “employing/using” is an example of one of a multitude of suitable possibilities that may, or may not, be employed to one or more of the various embodiments.

[0058] The term configured may relate to the capacity of a device whether the device is in an operational or non-operational state. Configured may refer to specific settings in a device that effect the operational characteristics of the device whether the device is in an operational or non-operational state. In other words, the hardware, software, firmware, registers, memory values, and/or the like may be “configured” within a device, whether the device is in an operational or nonoperational state, to provide the device with specific characteristics. Terms such as “a control message to cause in a device” may mean that a control message has parameters that may be used to configure specific characteristics or may be used to implement certain actions in the device, whether the device is in an operational or non-operational state.

[0059] In this disclosure, parameters (or equally called, fields, or Information elements: IEs) may comprise one or more information objects, and an information object may comprise one or more other objects. For example, if parameter (IE) N comprises parameter (IE) M, and parameter (IE) M comprises parameter (IE) K, and parameter (IE) K comprises parameter (information element) J. Then, for example, N comprises K, and N comprises J. In an example embodiment, when one or more messages comprise a plurality of parameters, it implies that a parameter in the plurality of parameters is in at least one of the one or more messages, but does not have to be in each of the one or more messages.

[0060] Many features presented are described as being optional through the use of “may” or the use of parentheses. For the sake of brevity and legibility, the present disclosure does not explicitly recite each and every permutation that may be obtained by choosing from the set of optional features. The present disclosure is to be interpreted as explicitly disclosing all such permutations. For example, a system described as having three optional features may be embodied in seven ways, namely with just one of the three possible features, with any two of the three possible features or with three of the three possible features.

[0061] Many of the elements described in the disclosed embodiments may be implemented as modules. A module is defined here as an element that performs a defined function and has a defined interface to other elements. The modules described in this disclosure may be implemented in hardware, software in combination with hardware, firmware, wetware (e.g. hardware with a biological element) or a combination thereof, which may be behaviorally equivalent. For example, modules may be implemented as a software routine written in a computer language configured to be executed by a hardware machine (such as C, C++, Fortran, Java, Basic, Matlab or the like) or a modeling/simulation program such as Simulink, Stateflow, GNU Octave, or LabVIEWMathScript. It may be possible to implement modules using physical hardware that incorporates discrete or programmable analog, digital and/or

quantum hardware. Examples of programmable hardware comprise: computers, microcontrollers, microprocessors, application-specific integrated circuits (ASICs); field programmable gate arrays (FPGAs); and complex programmable logic devices (CPLDs). Computers, microcontrollers and microprocessors are programmed using languages such as assembly, C, C++ or the like. FPGAs, ASICs and CPLDs are often programmed using hardware description languages (HDL) such as VHSIC hardware description language (VHDL) or Verilog that configure connections between internal hardware modules with lesser functionality on a programmable device. The mentioned technologies are often used in combination to achieve the result of a functional module.

[0062] FIG. 1A illustrates an example of a mobile communication network 100 in which embodiments of the present disclosure may be implemented. The mobile communication network 100 may be, for example, a public land mobile network (PLMN) run by a network operator. As illustrated in FIG. 1A, the mobile communication network 100 includes a core network (CN) 102, a radio access network (RAN) 104, and a wireless device 106.

[0063] The CN 102 may provide the wireless device 106 with an interface to one or more data networks (DNs), such as public DN (e.g., the Internet), private DN, and/or intra-operator DN. As part of the interface functionality, the CN 102 may set up end-to-end connections between the wireless device 106 and the one or more DN, authenticate the wireless device 106, and provide charging functionality.

[0064] The RAN 104 may connect the CN 102 to the wireless device 106 through radio communications over an air interface. As part of the radio communications, the RAN 104 may provide scheduling, radio resource management, and retransmission protocols. The communication direction from the RAN 104 to the wireless device 106 over the air interface is known as the downlink and the communication direction from the wireless device 106 to the RAN 104 over the air interface is known as the uplink. Downlink transmissions may be separated from uplink transmissions using frequency division duplexing (FDD), time-division duplexing (TDD), and/or some combination of the two duplexing techniques.

[0065] The term wireless device may be used throughout this disclosure to refer to and encompass any mobile device or fixed (non-mobile) device for which wireless communication is needed or usable. For example, a wireless device may be a telephone, smart phone, tablet, computer, laptop, sensor, meter, wearable device, Internet of Things (IoT) device, vehicle road side unit (RSU), relay node, automobile, and/or any combination thereof. The term wireless device encompasses other terminology, including user equipment (UE), user terminal (UT), access terminal (AT), mobile station, handset, wireless transmit and receive unit (WTRU), and/or wireless communication device.

[0066] The RAN 104 may include one or more base stations (not shown). The term base station may be used throughout this disclosure to refer to and encompass a Node B (associated with UMTS and/or 3G standards), an Evolved Node B (eNB, associated with E-UTRA and/or 4G standards), a remote radio head (RRH), a baseband processing unit coupled to one or more RRHs, a repeater node or relay node used to extend the coverage area of a donor node, a Next Generation Evolved Node B (ng-eNB), a Generation Node B (gNB, associated with NR and/or 5G standards), an access point (AP, associated with, for example, WiFi or any other suitable wireless communication standard), and/or any combination thereof. A base station may comprise at least one gNB Central Unit (gNB-CU) and at least one a gNB Distributed Unit (gNB-DU).

[0067] A base station included in the RAN 104 may include one or more sets of antennas for communicating with the wireless device 106 over the air interface. For example, one or more of the base stations may include three sets of antennas to respectively control three cells (or sectors). The size of a cell may be determined by a range at which a receiver (e.g., a base station receiver) can successfully receive the transmissions from a transmitter (e.g., a wireless device transmitter) operating in the cell. Together, the cells of the base stations may provide radio coverage to the wireless device 106 over a wide geographic area to support wireless device mobility.

[0068] In addition to three-sector sites, other implementations of base stations are possible. For example, one or more of the base stations in the RAN 104 may be implemented as a sectored site with more or less than three sectors. One or more of the base stations in the RAN 104 may be implemented as an access point, as a baseband processing unit coupled to several remote radio heads (RRHs), and/or as a repeater or relay node used to extend the coverage area of a donor node. A baseband processing unit coupled to RRHs may be part of a centralized or cloud RAN architecture, where the baseband processing unit may be either centralized in a pool of baseband processing units or virtualized. A repeater node may amplify and rebroadcast a radio signal received from a donor node. A relay node may perform the same/similar functions as a repeater node but may decode the radio signal received from the donor node to remove noise before amplifying and rebroadcasting the radio signal.

[0069] The RAN 104 may be deployed as a homogenous network of macrocell base stations that have similar antenna patterns and similar high-level transmit powers. The RAN 104 may be deployed as a heterogeneous network. In heterogeneous networks, small cell base stations may be used to provide small coverage areas, for example, coverage areas that overlap with the comparatively larger coverage areas provided by macrocell base stations. The small

coverage areas may be provided in areas with high data traffic (or so-called “hotspots”) or in areas with weak macrocell coverage. Examples of small cell base stations include, in order of decreasing coverage area, microcell base stations, picocell base stations, and femtocell base stations or home base stations.

[0070] The Third-Generation Partnership Project (3GPP) was formed in 1998 to provide global standardization of specifications for mobile communication networks similar to the mobile communication network 100 in FIG. 1A. To date, 3GPP has produced specifications for three generations of mobile networks: a third generation (3G) network known as Universal Mobile Telecommunications System (UMTS), a fourth generation (4G) network known as Long-Term Evolution (LTE), and a fifth generation (5G) network known as 5G System (5GS). Embodiments of the present disclosure are described with reference to the RAN of a 3GPP 5G network, referred to as next-generation RAN (NG-RAN). Embodiments may be applicable to RANs of other mobile communication networks, such as the RAN 104 in FIG. 1A, the RANs of earlier 3G and 4G networks, and those of future networks yet to be specified (e.g., a 3GPP 6G network). NG-RAN implements 5G radio access technology known as New Radio (NR) and may be provisioned to implement 4G radio access technology or other radio access technologies, including non-3GPP radio access technologies.

[0071] FIG. 1B illustrates another example mobile communication network 150 in which embodiments of the present disclosure may be implemented. Mobile communication network 150 may be, for example, a PLMN run by a network operator. As illustrated in FIG. 1B, mobile communication network 150 includes a 5G core network (5G-CN) 152, an NG-RAN 154, and UEs 156A and 156B (collectively UEs 156). These components may be implemented and operate in the same or similar manner as corresponding components described with respect to FIG. 1A.

[0072] The 5G-CN 152 provides the UEs 156 with an interface to one or more DN, such as public DN (e.g., the Internet), private DN, and/or intra-operator DN. As part of the interface functionality, the 5G-CN 152 may set up end-to-end connections between the UEs 156 and the one or more DN, authenticate the UEs 156, and provide charging functionality. Compared to the CN of a 3GPP 4G network, the basis of the 5G-CN 152 may be a service-based architecture. This means that the architecture of the nodes making up the 5G-CN 152 may be defined as network functions that offer services via interfaces to other network functions. The network functions of the 5G-CN 152 may be implemented in several ways, including as network elements on dedicated or shared hardware, as software instances

running on dedicated or shared hardware, or as virtualized functions instantiated on a platform (e.g., a cloud-based platform).

[0073] As illustrated in FIG. 1B, the 5G-CN 152 includes an Access and Mobility Management Function (AMF) 158A and a User Plane Function (UPF) 158B, which are shown as one component AMF/UPF 158 in FIG. 1B for ease of illustration. The UPF 158B may serve as a gateway between the NG-RAN 154 and the one or more DNs. The UPF 158B may perform functions such as packet routing and forwarding, packet inspection and user plane policy rule enforcement, traffic usage reporting, uplink classification to support routing of traffic flows to the one or more DNs, quality of service (QoS) handling for the user plane (e.g., packet filtering, gating, uplink/downlink rate enforcement, and uplink traffic verification), downlink packet buffering, and downlink data notification triggering. The UPF 158B may serve as an anchor point for intra-/inter-Radio Access Technology (RAT) mobility, an external protocol (or packet) data unit (PDU) session point of interconnect to the one or more DNs, and/or a branching point to support a multi-homed PDU session. The UEs 156 may be configured to receive services through a PDU session, which is a logical connection between a UE and a DN.

[0074] The AMF 158A may perform functions such as Non-Access Stratum (NAS) signaling termination, NAS signaling security, Access Stratum (AS) security control, inter-CN node signaling for mobility between 3GPP access networks, idle mode UE reachability (e.g., control and execution of paging retransmission), registration area management, intra-system and inter-system mobility support, access authentication, access authorization including checking of roaming rights, mobility management control (subscription and policies), network slicing support, and/or session management function (SMF) selection. NAS may refer to the functionality operating between a CN and a UE, and AS may refer to the functionality operating between the UE and a RAN.

[0075] The 5G-CN 152 may include one or more additional network functions that are not shown in FIG. 1B for the sake of clarity. For example, the 5G-CN 152 may include one or more of a Session Management Function (SMF), an NR Repository Function (NRF), a Policy Control Function (PCF), a Network Exposure Function (NEF), a Unified Data Management (UDM), an Application Function (AF), and/or an Authentication Server Function (AUSF).

[0076] The NG-RAN 154 may connect the 5G-CN 152 to the UEs 156 through radio communications over the air interface. The NG-RAN 154 may include one or more gNBs, illustrated as gNB 160A and gNB 160B (collectively gNBs 160) and/or one or more ng-eNBs, illustrated as ng-eNB 162A and ng-eNB 162B (collectively ng-eNBs 162). The gNBs 160 and ng-eNBs 162 may be more generically referred to as base stations. The gNBs

160 and ng-eNBs 162 may include one or more sets of antennas for communicating with the UEs 156 over an air interface. For example, one or more of the gNBs 160 and/or one or more of the ng-eNBs 162 may include three sets of antennas to respectively control three cells (or sectors). Together, the cells of the gNBs 160 and the ng-eNBs 162 may provide radio coverage to the UEs 156 over a wide geographic area to support UE mobility.

[0077] As shown in FIG. 1B, the gNBs 160 and/or the ng-eNBs 162 may be connected to the 5G-CN 152 by means of an NG interface and to other base stations by an Xn interface. The NG and Xn interfaces may be established using direct physical connections and/or indirect connections over an underlying transport network, such as an internet protocol (IP) transport network. The gNBs 160 and/or the ng-eNBs 162 may be connected to the UEs 156 by means of a Uu interface. For example, as illustrated in FIG. 1B, gNB 160A may be connected to the UE 156A by means of a Uu interface. The NG, Xn, and Uu interfaces are associated with a protocol stack. The protocol stacks associated with the interfaces may be used by the network elements in FIG. 1B to exchange data and signaling messages and may include two planes: a user plane and a control plane. The user plane may handle data of interest to a user. The control plane may handle signaling messages of interest to the network elements.

[0078] The gNBs 160 and/or the ng-eNBs 162 may be connected to one or more AMF/UPF functions of the 5G-CN 152, such as the AMF/UPF 158, by means of one or more NG interfaces. For example, the gNB 160A may be connected to the UPF 158B of the AMF/UPF 158 by means of an NG-User plane (NG-U) interface. The NG-U interface may provide delivery (e.g., non-guaranteed delivery) of user plane PDUs between the gNB 160A and the UPF 158B. The gNB 160A may be connected to the AMF 158A by means of an NG-Control plane (NG-C) interface. The NG-C interface may provide, for example, NG interface management, UE context management, UE mobility management, transport of NAS messages, paging, PDU session management, and configuration transfer and/or warning message transmission.

[0079] The gNBs 160 may provide NR user plane and control plane protocol terminations towards the UEs 156 over the Uu interface. For example, the gNB 160A may provide NR user plane and control plane protocol terminations toward the UE 156A over a Uu interface associated with a first protocol stack. The ng-eNBs 162 may provide Evolved UMTS Terrestrial Radio Access (E-UTRA) user plane and control plane protocol terminations towards the UEs 156 over a Uu interface, where E-UTRA refers to the 3GPP 4G radio-access technology. For example, the ng-eNB 162B may provide E-UTRA user plane and control plane protocol terminations towards the UE 156B over a Uu interface associated with a second protocol stack.

[0080] The 5G-CN 152 was described as being configured to handle NR and 4G radio accesses. It will be appreciated by one of ordinary skill in the art that it may be possible for NR to connect to a 4G core network in a mode known as “non-standalone operation.” In non-standalone operation, a 4G core network is used to provide (or at least support) control-plane functionality (e.g., initial access, mobility, and paging). Although only one AMF/UPF 158 is shown in FIG. 1B, one gNB or ng-eNB may be connected to multiple AMF/UPF nodes to provide redundancy and/or to load share across the multiple AMF/UPF nodes.

[0081] As discussed, an interface (e.g., Uu, Xn, and NG interfaces) between the network elements in FIG. 1B may be associated with a protocol stack that the network elements use to exchange data and signaling messages. A protocol stack may include two planes: a user plane and a control plane. The user plane may handle data of interest to a user, and the control plane may handle signaling messages of interest to the network elements.

[0082] FIG. 2A and FIG. 2B respectively illustrate examples of NR user plane and NR control plane protocol stacks for the Uu interface that lies between a UE 210 and a gNB 220. The protocol stacks illustrated in FIG. 2A and FIG. 2B may be the same or similar to those used for the Uu interface between, for example, the UE 156A and the gNB 160A shown in FIG. 1B.

[0083] FIG. 2A illustrates a NR user plane protocol stack comprising five layers implemented in the UE 210 and the gNB 220. At the bottom of the protocol stack, physical layers (PHYs) 211 and 221 may provide transport services to the higher layers of the protocol stack and may correspond to layer 1 of the Open Systems Interconnection (OSI) model. The next four protocols above PHYs 211 and 221 comprise media access control layers (MACs) 212 and 222, radio link control layers (RLCs) 213 and 223, packet data convergence protocol layers (PDCPs) 214 and 224, and service data application protocol layers (SDAPs) 215 and 225. Together, these four protocols may make up layer 2, or the data link layer, of the OSI model.

[0084] FIG. 3 illustrates an example of services provided between protocol layers of the NR user plane protocol stack. Starting from the top of FIG. 2A and FIG. 3, the SDAPs 215 and 225 may perform QoS flow handling. The UE 210 may receive services through a PDU session, which may be a logical connection between the UE 210 and a DN. The PDU session may have one or more QoS flows. A UPF of a CN (e.g., the UPF 158B) may map IP packets to the one or more QoS flows of the PDU session based on QoS requirements (e.g., in terms of delay, data rate, and/or error rate). The SDAPs 215 and 225 may perform mapping/de-mapping between the one or more QoS flows and one or more data radio bearers. The mapping/de-mapping between the QoS flows and the data radio bearers may be determined

by the SDAP 225 at the gNB 220. The SDAP 215 at the UE 210 may be informed of the mapping between the QoS flows and the data radio bearers through reflective mapping or control signaling received from the gNB 220. For reflective mapping, the SDAP 225 at the gNB 220 may mark the downlink packets with a QoS flow indicator (QFI), which may be observed by the SDAP 215 at the UE 210 to determine the mapping/de-mapping between the QoS flows and the data radio bearers.

[0085] The PDCPs 214 and 224 may perform header compression/decompression to reduce the amount of data that needs to be transmitted over the air interface, ciphering/deciphering to prevent unauthorized decoding of data transmitted over the air interface, and integrity protection (to ensure control messages originate from intended sources. The PDCPs 214 and 224 may perform retransmissions of undelivered packets, in-sequence delivery and reordering of packets, and removal of packets received in duplicate due to, for example, an intra-gNB handover. The PDCPs 214 and 224 may perform packet duplication to improve the likelihood of the packet being received and, at the receiver, remove any duplicate packets. Packet duplication may be useful for services that require high reliability.

[0086] Although not shown in FIG. 3, PDCPs 214 and 224 may perform mapping/de-mapping between a split radio bearer and RLC channels in a dual connectivity scenario. Dual connectivity is a technique that allows a UE to connect to two cells or, more generally, two cell groups: a master cell group (MCG) and a secondary cell group (SCG). A split bearer is when a single radio bearer, such as one of the radio bearers provided by the PDCPs 214 and 224 as a service to the SDAPs 215 and 225, is handled by cell groups in dual connectivity. The PDCPs 214 and 224 may map/de-map the split radio bearer between RLC channels belonging to cell groups.

[0087] The RLCs 213 and 223 may perform segmentation, retransmission through Automatic Repeat Request (ARQ), and removal of duplicate data units received from MACs 212 and 222, respectively. The RLCs 213 and 223 may support three transmission modes: transparent mode (TM); unacknowledged mode (UM); and acknowledged mode (AM). Based on the transmission mode an RLC is operating, the RLC may perform one or more of the noted functions. The RLC configuration may be per logical channel with no dependency on numerologies and/or Transmission Time Interval (TTI) durations. As shown in FIG. 3, the RLCs 213 and 223 may provide RLC channels as a service to PDCPs 214 and 224, respectively.

[0088] The MACs 212 and 222 may perform multiplexing/demultiplexing of logical channels and/or mapping between logical channels and transport channels. The multiplexing/demultiplexing may include multiplexing/demultiplexing of data units,

belonging to the one or more logical channels, into/from Transport Blocks (TBs) delivered to/from the PHYs 211 and 221. The MAC 222 may be configured to perform scheduling, scheduling information reporting, and priority handling between UEs by means of dynamic scheduling. Scheduling may be performed in the gNB 220 (at the MAC 222) for downlink and uplink. The MACs 212 and 222 may be configured to perform error correction through Hybrid Automatic Repeat Request (HARQ) (e.g., one HARQ entity per carrier in case of Carrier Aggregation (CA)), priority handling between logical channels of the UE 210 by means of logical channel prioritization, and/or padding. The MACs 212 and 222 may support one or more numerologies and/or transmission timings. In an example, mapping restrictions in a logical channel prioritization may control which numerology and/or transmission timing a logical channel may use. As shown in FIG. 3, the MACs 212 and 222 may provide logical channels as a service to the RLCs 213 and 223.

[0089] The PHYs 211 and 221 may perform mapping of transport channels to physical channels and digital and analog signal processing functions for sending and receiving information over the air interface. These digital and analog signal processing functions may include, for example, coding/decoding and modulation/demodulation. The PHYs 211 and 221 may perform multi-antenna mapping. As shown in FIG. 3, the PHYs 211 and 221 may provide one or more transport channels as a service to the MACs 212 and 222.

[0090] FIG. 4A illustrates an example downlink data flow through the NR user plane protocol stack. FIG. 4A illustrates a downlink data flow of three IP packets (n , $n+1$, and m) through the NR user plane protocol stack to generate two TBs at the gNB 220. An uplink data flow through the NR user plane protocol stack may be similar to the downlink data flow depicted in FIG. 4A.

[0091] The downlink data flow of FIG. 4A begins when SDAP 225 receives the three IP packets from one or more QoS flows and maps the three packets to radio bearers. In FIG. 4A, the SDAP 225 maps IP packets n and $n+1$ to a first radio bearer 402 and maps IP packet m to a second radio bearer 404. An SDAP header (labeled with an “H” in FIG. 4A) is added to an IP packet. The data unit from/to a higher protocol layer is referred to as a service data unit (SDU) of the lower protocol layer and the data unit to/from a lower protocol layer is referred to as a protocol data unit (PDU) of the higher protocol layer. As shown in FIG. 4A, the data unit from the SDAP 225 is an SDU of lower protocol layer PDCP 224 and is a PDU of the SDAP 225.

[0092] The remaining protocol layers in FIG. 4A may perform their associated functionality (e.g., with respect to FIG. 3), add corresponding headers, and forward their respective outputs to the next lower layer. For example, the PDCP 224 may perform IP-header

compression and ciphering and forward its output to the RLC 223. The RLC 223 may optionally perform segmentation (e.g., as shown for IP packet *m* in FIG. 4A) and forward its output to the MAC 222. The MAC 222 may multiplex a number of RLC PDUs and may attach a MAC subheader to an RLC PDU to form a transport block. In NR, the MAC subheaders may be distributed across the MAC PDU, as illustrated in FIG. 4A. In LTE, the MAC subheaders may be entirely located at the beginning of the MAC PDU. The NR MAC PDU structure may reduce processing time and associated latency because the MAC PDU subheaders may be computed before the full MAC PDU is assembled.

[0093] FIG. 4B illustrates an example format of a MAC subheader in a MAC PDU. The MAC subheader includes: an SDU length field for indicating the length (e.g., in bytes) of the MAC SDU to which the MAC subheader corresponds; a logical channel identifier (LCID) field for identifying the logical channel from which the MAC SDU originated to aid in the demultiplexing process; a flag (F) for indicating the size of the SDU length field; and a reserved bit (R) field for future use.

[0094] FIG. 4B further illustrates MAC control elements (CEs) inserted into the MAC PDU by a MAC, such as MAC 223 or MAC 222. For example, FIG. 4B illustrates two MAC CEs inserted into the MAC PDU. MAC CEs may be inserted at the beginning of a MAC PDU for downlink transmissions (as shown in FIG. 4B) and at the end of a MAC PDU for uplink transmissions. MAC CEs may be used for in-band control signaling. Example MAC CEs include: scheduling-related MAC CEs, such as buffer status reports and power headroom reports; activation/deactivation MAC CEs, such as those for activation/deactivation of PDCP duplication detection, channel state information (CSI) reporting, sounding reference signal (SRS) transmission, and prior configured components; discontinuous reception (DRX) related MAC CEs; timing advance MAC CEs; and random access related MAC CEs. A MAC CE may be preceded by a MAC subheader with a similar format as described for MAC SDUs and may be identified with a reserved value in the LCID field that indicates the type of control information included in the MAC CE.

[0095] Before describing the NR control plane protocol stack, logical channels, transport channels, and physical channels are first described as well as a mapping between the channel types. One or more of the channels may be used to carry out functions associated with the NR control plane protocol stack described later below.

[0096] FIG. 5A and FIG. 5B illustrate, for downlink and uplink respectively, a mapping between logical channels, transport channels, and physical channels. Information is passed through channels between the RLC, the MAC, and the PHY of the NR protocol stack. A logical channel may be used between the RLC and the MAC and may be classified as a

control channel that carries control and configuration information in the NR control plane or as a traffic channel that carries data in the NR user plane. A logical channel may be classified as a dedicated logical channel that is dedicated to a specific UE or as a common logical channel that may be used by more than one UE. A logical channel may also be defined by the type of information it carries. The set of logical channels defined by NR include, for example:

- a paging control channel (PCCH) for carrying paging messages used to page a UE whose location is not known to the network on a cell level;
- a broadcast control channel (BCCH) for carrying system information messages in the form of a master information block (MIB) and several system information blocks (SIBs), wherein the system information messages may be used by the UEs to obtain information about how a cell is configured and how to operate within the cell;
- a common control channel (CCCH) for carrying control messages together with random access;
- a dedicated control channel (DCCH) for carrying control messages to/from a specific the UE to configure the UE; and
- a dedicated traffic channel (DTCH) for carrying user data to/from a specific the UE.

[0097] Transport channels are used between the MAC and PHY layers and may be defined by how the information they carry is transmitted over the air interface. The set of transport channels defined by NR include, for example:

- a paging channel (PCH) for carrying paging messages that originated from the PCCH;
- a broadcast channel (BCH) for carrying the MIB from the BCCH;
- a downlink shared channel (DL-SCH) for carrying downlink data and signaling messages, including the SIBs from the BCCH;
- an uplink shared channel (UL-SCH) for carrying uplink data and signaling messages; and
- a random access channel (RACH) for allowing a UE to contact the network without any prior scheduling.

[0098] The PHY may use physical channels to pass information between processing levels of the PHY. A physical channel may have an associated set of time-frequency resources for carrying the information of one or more transport channels. The PHY may generate control information to support the low-level operation of the PHY and provide the control

information to the lower levels of the PHY via physical control channels, known as L1/L2 control channels. The set of physical channels and physical control channels defined by NR include, for example:

- a physical broadcast channel (PBCH) for carrying the MIB from the BCH;
- a physical downlink shared channel (PDSCH) for carrying downlink data and signaling messages from the DL-SCH, as well as paging messages from the PCH;
- a physical downlink control channel (PDCCH) for carrying downlink control information (DCI), which may include downlink scheduling commands, uplink scheduling grants, and uplink power control commands;
- a physical uplink shared channel (PUSCH) for carrying uplink data and signaling messages from the UL-SCH and in some instances uplink control information (UCI) as described below;
- a physical uplink control channel (PUCCH) for carrying UCI, which may include HARQ acknowledgments, channel quality indicators (CQI), pre-coding matrix indicators (PMI), rank indicators (RI), and scheduling requests (SR); and
- a physical random access channel (PRACH) for random access.

[0099] Similar to the physical control channels, the physical layer generates physical signals to support the low-level operation of the physical layer. As shown in FIG. 5A and FIG. 5B, the physical layer signals defined by NR include: primary synchronization signals (PSS), secondary synchronization signals (SSS), channel state information reference signals (CSI-RS), demodulation reference signals (DMRS), sounding reference signals (SRS), and phase-tracking reference signals (PT-RS). These physical layer signals will be described in greater detail below.

[0100] Control Plane Protocol Stack

[0101] FIG. 2B illustrates an example NR control plane protocol stack. As shown in FIG. 2B, the NR control plane protocol stack may use the same/similar first four protocol layers as the example NR user plane protocol stack. These four protocol layers include the PHYs 211 and 221, the MACs 212 and 222, the RLCs 213 and 223, and the PDCPs 214 and 224. Instead of having the SDAPs 215 and 225 at the top of the stack as in the NR user plane protocol stack, the NR control plane stack has radio resource controls (RRCs) 216 and 226 and NAS protocols 217 and 237 at the top of the NR control plane protocol stack.

[0102] The NAS protocols 217 and 237 may provide control plane functionality between the UE 210 and the AMF 230 (e.g., the AMF 158A) or, more generally, between the UE 210 and the CN. The NAS protocols 217 and 237 may provide control plane functionality between the UE 210 and the AMF 230 via signaling messages, referred to as NAS messages. There is

no direct path between the UE 210 and the AMF 230 through which the NAS messages can be transported. The NAS messages may be transported using the AS of the Uu and NG interfaces. NAS protocols 217 and 237 may provide control plane functionality such as authentication, security, connection setup, mobility management, and session management.

[0103] The RRCs 216 and 226 may provide control plane functionality between the UE 210 and the gNB 220 or, more generally, between the UE 210 and the RAN. The RRCs 216 and 226 may provide control plane functionality between the UE 210 and the gNB 220 via signaling messages, referred to as RRC messages. RRC messages may be transmitted between the UE 210 and the RAN using signaling radio bearers and the same/similar PDCP, RLC, MAC, and PHY protocol layers. The MAC may multiplex control-plane and user-plane data into the same transport block (TB). The RRCs 216 and 226 may provide control plane functionality such as: broadcast of system information related to AS and NAS; paging initiated by the CN or the RAN; establishment, maintenance and release of an RRC connection between the UE 210 and the RAN; security functions including key management; establishment, configuration, maintenance and release of signaling radio bearers and data radio bearers; mobility functions; QoS management functions; the UE measurement reporting and control of the reporting; detection of and recovery from radio link failure (RLF); and/or NAS message transfer. As part of establishing an RRC connection, RRCs 216 and 226 may establish an RRC context, which may involve configuring parameters for communication between the UE 210 and the RAN.

[0104] FIG. 6 is an example diagram showing RRC state transitions of a UE. The UE may be the same or similar to the wireless device 106 depicted in FIG. 1A, the UE 210 depicted in FIG. 2A and FIG. 2B, or any other wireless device described in the present disclosure. As illustrated in FIG. 6, a UE may be in at least one of three RRC states: RRC connected 602 (e.g., RRC_CONNECTED), RRC idle 604 (e.g., RRC_IDLE), and RRC inactive 606 (e.g., RRC_INACTIVE).

[0105] In RRC connected 602, the UE has an established RRC context and may have at least one RRC connection with a base station. The base station may be similar to one of the one or more base stations included in the RAN 104 depicted in FIG. 1A, one of the gNBs 160 or ng-eNBs 162 depicted in FIG. 1B, the gNB 220 depicted in FIG. 2A and FIG. 2B, or any other base station described in the present disclosure. The base station with which the UE is connected may have the RRC context for the UE. The RRC context, referred to as the UE context, may comprise parameters for communication between the UE and the base station. These parameters may include, for example: one or more AS contexts; one or more radio link configuration parameters; bearer configuration information (e.g., relating to a data radio

bearer, signaling radio bearer, logical channel, QoS flow, and/or PDU session); security information; and/or PHY, MAC, RLC, PDCP, and/or SDAP layer configuration information. While in RRC connected 602, mobility of the UE may be managed by the RAN (e.g., the RAN 104 or the NG-RAN 154). The UE may measure the signal levels (e.g., reference signal levels) from a serving cell and neighboring cells and report these measurements to the base station currently serving the UE. The UE's serving base station may request a handover to a cell of one of the neighboring base stations based on the reported measurements. The RRC state may transition from RRC connected 602 to RRC idle 604 through a connection release procedure 608 or to RRC inactive 606 through a connection inactivation procedure 610.

[0106] In RRC idle 604, an RRC context may not be established for the UE. In RRC idle 604, the UE may not have an RRC connection with the base station. While in RRC idle 604, the UE may be in a sleep state for the majority of the time (e.g., to conserve battery power). The UE may wake up periodically (e.g., once in every discontinuous reception cycle) to monitor for paging messages from the RAN. Mobility of the UE may be managed by the UE through a procedure known as cell reselection. The RRC state may transition from RRC idle 604 to RRC connected 602 through a connection establishment procedure 612, which may involve a random access procedure as discussed in greater detail below.

[0107] In RRC inactive 606, the RRC context previously established is maintained in the UE and the base station. This allows for a fast transition to RRC connected 602 with reduced signaling overhead as compared to the transition from RRC idle 604 to RRC connected 602. While in RRC inactive 606, the UE may be in a sleep state and mobility of the UE may be managed by the UE through cell reselection. The RRC state may transition from RRC inactive 606 to RRC connected 602 through a connection resume procedure 614 or to RRC idle 604 through a connection release procedure 616 that may be the same as or similar to connection release procedure 608.

[0108] An RRC state may be associated with a mobility management mechanism. In RRC idle 604 and RRC inactive 606, mobility is managed by the UE through cell reselection. The purpose of mobility management in RRC idle 604 and RRC inactive 606 is to allow the network to be able to notify the UE of an event via a paging message without having to broadcast the paging message over the entire mobile communications network. The mobility management mechanism used in RRC idle 604 and RRC inactive 606 may allow the network to track the UE on a cell-group level so that the paging message may be broadcast over the cells of the cell group that the UE currently resides within instead of the entire mobile communication network. The mobility management mechanisms for RRC idle 604 and RRC

inactive 606 track the UE on a cell-group level. They may do so using different granularities of grouping. For example, there may be three levels of cell-grouping granularity: individual cells; cells within a RAN area identified by a RAN area identifier (RAI); and cells within a group of RAN areas, referred to as a tracking area and identified by a tracking area identifier (TAI).

- [0109]** Tracking areas may be used to track the UE at the CN level. The CN (e.g., the CN 102 or the 5G-CN 152) may provide the UE with a list of TAIs associated with a UE registration area. If the UE moves, through cell reselection, to a cell associated with a TAI not included in the list of TAIs associated with the UE registration area, the UE may perform a registration update with the CN to allow the CN to update the UE's location and provide the UE with a new the UE registration area.
- [0110]** RAN areas may be used to track the UE at the RAN level. For a UE in RRC inactive 606 state, the UE may be assigned a RAN notification area. A RAN notification area may comprise one or more cell identities, a list of RAIs, or a list of TAIs. In an example, a base station may belong to one or more RAN notification areas. In an example, a cell may belong to one or more RAN notification areas. If the UE moves, through cell reselection, to a cell not included in the RAN notification area assigned to the UE, the UE may perform a notification area update with the RAN to update the UE's RAN notification area.
- [0111]** A base station storing an RRC context for a UE or a last serving base station of the UE may be referred to as an anchor base station. An anchor base station may maintain an RRC context for the UE at least during a period of time that the UE stays in a RAN notification area of the anchor base station and/or during a period of time that the UE stays in RRC inactive 606.
- [0112]** A gNB, such as gNBs 160 in FIG. 1B, may be split in two parts: a central unit (gNB-CU), and one or more distributed units (gNB-DU). A gNB-CU may be coupled to one or more gNB-DUs using an F1 interface. The gNB-CU may comprise the RRC, the PDCP, and the SDAP. A gNB-DU may comprise the RLC, the MAC, and the PHY.
- [0113]** In NR, the physical signals and physical channels (discussed with respect to FIG. 5A and FIG. 5B) may be mapped onto orthogonal frequency divisional multiplexing (OFDM) symbols. OFDM is a multicarrier communication scheme that transmits data over F orthogonal subcarriers (or tones). Before transmission, the data may be mapped to a series of complex symbols (e.g., M-quadrature amplitude modulation (M-QAM) or M-phase shift keying (M-PSK) symbols), referred to as source symbols, and divided into F parallel symbol streams. The F parallel symbol streams may be treated as though they are in the frequency domain and used as inputs to an Inverse Fast Fourier Transform (IFFT) block that transforms

them into the time domain. The IFFT block may take in F source symbols at a time, one from each of the F parallel symbol streams, and use each source symbol to modulate the amplitude and phase of one of F sinusoidal basis functions that correspond to the F orthogonal subcarriers. The output of the IFFT block may be F time-domain samples that represent the summation of the F orthogonal subcarriers. The F time-domain samples may form a single OFDM symbol. After some processing (e.g., addition of a cyclic prefix) and up-conversion, an OFDM symbol provided by the IFFT block may be transmitted over the air interface on a carrier frequency. The F parallel symbol streams may be mixed using an FFT block before being processed by the IFFT block. This operation produces Discrete Fourier Transform (DFT)-precoded OFDM symbols and may be used by UEs in the uplink to reduce the peak to average power ratio (PAPR). Inverse processing may be performed on the OFDM symbol at a receiver using an FFT block to recover the data mapped to the source symbols.

[0114] FIG. 7 illustrates an example configuration of an NR frame into which OFDM symbols are grouped. An NR frame may be identified by a system frame number (SFN). The SFN may repeat with a period of 1024 frames. As illustrated, one NR frame may be 10 milliseconds (ms) in duration and may include 10 subframes that are 1 ms in duration. A subframe may be divided into slots that include, for example, 14 OFDM symbols per slot.

[0115] The duration of a slot may depend on the numerology used for the OFDM symbols of the slot. In NR, a flexible numerology is supported to accommodate different cell deployments (e.g., cells with carrier frequencies below 1 GHz up to cells with carrier frequencies in the mm-wave range). A numerology may be defined in terms of subcarrier spacing and cyclic prefix duration. For a numerology in NR, subcarrier spacings may be scaled up by powers of two from a baseline subcarrier spacing of 15 kHz, and cyclic prefix durations may be scaled down by powers of two from a baseline cyclic prefix duration of 4.7 μ s. For example, NR defines numerologies with the following subcarrier spacing/cyclic prefix duration combinations: 15 kHz/4.7 μ s; 30 kHz/2.3 μ s; 60 kHz/1.2 μ s; 120 kHz/0.59 μ s; and 240 kHz/0.29 μ s.

[0116] A slot may have a fixed number of OFDM symbols (e.g., 14 OFDM symbols). A numerology with a higher subcarrier spacing has a shorter slot duration and, correspondingly, more slots per subframe. FIG. 7 illustrates this numerology-dependent slot duration and slots-per-subframe transmission structure (the numerology with a subcarrier spacing of 240 kHz is not shown in FIG. 7 for ease of illustration). A subframe in NR may be used as a numerology-independent time reference, while a slot may be used as the unit upon which uplink and downlink transmissions are scheduled. To support low latency, scheduling in NR may be decoupled from the slot duration and start at any OFDM symbol and last for as many

symbols as needed for a transmission. These partial slot transmissions may be referred to as mini-slot or subslot transmissions.

[0117] FIG. 8 illustrates an example configuration of a slot in the time and frequency domain for an NR carrier. The slot includes resource elements (REs) and resource blocks (RBs). An RE is the smallest physical resource in NR. An RE spans one OFDM symbol in the time domain by one subcarrier in the frequency domain as shown in FIG. 8. An RB spans twelve consecutive REs in the frequency domain as shown in FIG. 8. An NR carrier may be limited to a width of 275 RBs or $275 \times 12 = 3300$ subcarriers. Such a limitation, if used, may limit the NR carrier to 50, 100, 200, and 400 MHz for subcarrier spacings of 15, 30, 60, and 120 kHz, respectively, where the 400 MHz bandwidth may be set based on a 400 MHz per carrier bandwidth limit.

[0118] FIG. 8 illustrates a single numerology being used across the entire bandwidth of the NR carrier. In other example configurations, multiple numerologies may be supported on the same carrier.

[0119] NR may support wide carrier bandwidths (e.g., up to 400 MHz for a subcarrier spacing of 120 kHz). Not all UEs may be able to receive the full carrier bandwidth (e.g., due to hardware limitations). Also, receiving the full carrier bandwidth may be prohibitive in terms of UE power consumption. In an example, to reduce power consumption and/or for other purposes, a UE may adapt the size of the UE's receive bandwidth based on the amount of traffic the UE is scheduled to receive. This is referred to as bandwidth adaptation.

[0120] NR defines bandwidth parts (BWPs) to support UEs not capable of receiving the full carrier bandwidth and to support bandwidth adaptation. In an example, a BWP may be defined by a subset of contiguous RBs on a carrier. A UE may be configured (e.g., via RRC layer) with one or more downlink BWPs and one or more uplink BWPs per serving cell (e.g., up to four downlink BWPs and up to four uplink BWPs per serving cell). At a given time, one or more of the configured BWPs for a serving cell may be active. These one or more BWPs may be referred to as active BWPs of the serving cell. When a serving cell is configured with a secondary uplink carrier, the serving cell may have one or more first active BWPs in the uplink carrier and one or more second active BWPs in the secondary uplink carrier.

[0121] For unpaired spectra, a downlink BWP from a set of configured downlink BWPs may be linked with an uplink BWP from a set of configured uplink BWPs if a downlink BWP index of the downlink BWP and an uplink BWP index of the uplink BWP are the same. For unpaired spectra, a UE may expect that a center frequency for a downlink BWP is the same as a center frequency for an uplink BWP.

- [0122]** For a downlink BWP in a set of configured downlink BWPs on a primary cell (PCell), a base station may configure a UE with one or more control resource sets (CORESETs) for at least one search space. A search space is a set of locations in the time and frequency domains where the UE may find control information. The search space may be a UE-specific search space or a common search space (potentially usable by a plurality of UEs). For example, a base station may configure a UE with a common search space, on a PCell or on a primary secondary cell (PSCell), in an active downlink BWP.
- [0123]** For an uplink BWP in a set of configured uplink BWPs, a BS may configure a UE with one or more resource sets for one or more PUCCH transmissions. A UE may receive downlink receptions (e.g., PDCCH or PDSCH) in a downlink BWP according to a configured numerology (e.g., subcarrier spacing and cyclic prefix duration) for the downlink BWP. The UE may transmit uplink transmissions (e.g., PUCCH or PUSCH) in an uplink BWP according to a configured numerology (e.g., subcarrier spacing and cyclic prefix length for the uplink BWP).
- [0124]** One or more BWP indicator fields may be provided in Downlink Control Information (DCI). A value of a BWP indicator field may indicate which BWP in a set of configured BWPs is an active downlink BWP for one or more downlink receptions. The value of the one or more BWP indicator fields may indicate an active uplink BWP for one or more uplink transmissions.
- [0125]** A base station may semi-statically configure a UE with a default downlink BWP within a set of configured downlink BWPs associated with a PCell. If the base station does not provide the default downlink BWP to the UE, the default downlink BWP may be an initial active downlink BWP. The UE may determine which BWP is the initial active downlink BWP based on a CORESET configuration obtained using the PBCH.
- [0126]** A base station may configure a UE with a BWP inactivity timer value for a PCell. The UE may start or restart a BWP inactivity timer at any appropriate time. For example, the UE may start or restart the BWP inactivity timer (*a*) when the UE detects a DCI indicating an active downlink BWP other than a default downlink BWP for a paired spectra operation; or (*b*) when a UE detects a DCI indicating an active downlink BWP or active uplink BWP other than a default downlink BWP or uplink BWP for an unpaired spectra operation. If the UE does not detect DCI during an interval of time (e.g., 1 ms or 0.5 ms), the UE may run the BWP inactivity timer toward expiration (for example, increment from zero to the BWP inactivity timer value, or decrement from the BWP inactivity timer value to zero). When the BWP inactivity timer expires, the UE may switch from the active downlink BWP to the default downlink BWP.

- [0127]** In an example, a base station may semi-statically configure a UE with one or more BWPs. A UE may switch an active BWP from a first BWP to a second BWP in response to receiving a DCI indicating the second BWP as an active BWP and/or in response to an expiry of the BWP inactivity timer (e.g., if the second BWP is the default BWP).
- [0128]** Downlink and uplink BWP switching (where BWP switching refers to switching from a currently active BWP to a not currently active BWP) may be performed independently in paired spectra. In unpaired spectra, downlink and uplink BWP switching may be performed simultaneously. Switching between configured BWPs may occur based on RRC signaling, DCI, expiration of a BWP inactivity timer, and/or an initiation of random access.
- [0129]** FIG. 9 illustrates an example of bandwidth adaptation using three configured BWPs for an NR carrier. A UE configured with the three BWPs may switch from one BWP to another BWP at a switching point. In the example illustrated in FIG. 9, the BWPs include: a BWP 902 with a bandwidth of 40 MHz and a subcarrier spacing of 15 kHz; a BWP 904 with a bandwidth of 10 MHz and a subcarrier spacing of 15 kHz; and a BWP 906 with a bandwidth of 20 MHz and a subcarrier spacing of 60 kHz. The BWP 902 may be an initial active BWP, and the BWP 904 may be a default BWP. The UE may switch between BWPs at switching points. In the example of FIG. 9, the UE may switch from the BWP 902 to the BWP 904 at a switching point 908. The switching at the switching point 908 may occur for any suitable reason, for example, in response to an expiry of a BWP inactivity timer (indicating switching to the default BWP) and/or in response to receiving a DCI indicating BWP 904 as the active BWP. The UE may switch at a switching point 910 from active BWP 904 to BWP 906 in response receiving a DCI indicating BWP 906 as the active BWP. The UE may switch at a switching point 912 from active BWP 906 to BWP 904 in response to an expiry of a BWP inactivity timer and/or in response receiving a DCI indicating BWP 904 as the active BWP. The UE may switch at a switching point 914 from active BWP 904 to BWP 902 in response receiving a DCI indicating BWP 902 as the active BWP.
- [0130]** If a UE is configured for a secondary cell with a default downlink BWP in a set of configured downlink BWPs and a timer value, UE procedures for switching BWPs on a secondary cell may be the same/similar as those on a primary cell. For example, the UE may use the timer value and the default downlink BWP for the secondary cell in the same/similar manner as the UE would use these values for a primary cell.
- [0131]** To provide for greater data rates, two or more carriers can be aggregated and simultaneously transmitted to/from the same UE using carrier aggregation (CA). The aggregated carriers in CA may be referred to as component carriers (CCs). When CA is used,

there are a number of serving cells for the UE, one for a CC. The CCs may have three configurations in the frequency domain.

[0132] FIG. 10A illustrates the three CA configurations with two CCs. In the intraband, contiguous configuration 1002, the two CCs are aggregated in the same frequency band (frequency band A) and are located directly adjacent to each other within the frequency band. In the intraband, non-contiguous configuration 1004, the two CCs are aggregated in the same frequency band (frequency band A) and are separated in the frequency band by a gap. In the interband configuration 1006, the two CCs are located in frequency bands (frequency band A and frequency band B).

[0133] In an example, up to 32 CCs may be aggregated. The aggregated CCs may have the same or different bandwidths, subcarrier spacing, and/or duplexing schemes (TDD or FDD). A serving cell for a UE using CA may have a downlink CC. For FDD, one or more uplink CCs may be optionally configured for a serving cell. The ability to aggregate more downlink carriers than uplink carriers may be useful, for example, when the UE has more data traffic in the downlink than in the uplink.

[0134] When CA is used, one of the aggregated cells for a UE may be referred to as a primary cell (PCell). The PCell may be the serving cell that the UE initially connects to at RRC connection establishment, reestablishment, and/or handover. The PCell may provide the UE with NAS mobility information and the security input. UEs may have different PCells. In the downlink, the carrier corresponding to the PCell may be referred to as the downlink primary CC (DL PCC). In the uplink, the carrier corresponding to the PCell may be referred to as the uplink primary CC (UL PCC). The other aggregated cells for the UE may be referred to as secondary cells (SCells). In an example, the SCells may be configured after the PCell is configured for the UE. For example, an SCell may be configured through an RRC Connection Reconfiguration procedure. In the downlink, the carrier corresponding to an SCell may be referred to as a downlink secondary CC (DL SCC). In the uplink, the carrier corresponding to the SCell may be referred to as the uplink secondary CC (UL SCC).

[0135] Configured SCells for a UE may be activated and deactivated based on, for example, traffic and channel conditions. Deactivation of an SCell may mean that PDCCH and PDSCH reception on the SCell is stopped and PUSCH, SRS, and CQI transmissions on the SCell are stopped. Configured SCells may be activated and deactivated using a MAC CE with respect to FIG. 4B. For example, a MAC CE may use a bitmap (e.g., one bit per SCell) to indicate which SCells (e.g., in a subset of configured SCells) for the UE are activated or deactivated. Configured SCells may be deactivated in response to an expiration of an SCell deactivation timer (e.g., one SCell deactivation timer per SCell).

[0136] Downlink control information, such as scheduling assignments and scheduling grants, for a cell may be transmitted on the cell corresponding to the assignments and grants, which is known as self-scheduling. The DCI for the cell may be transmitted on another cell, which is known as cross-carrier scheduling. Uplink control information (e.g., HARQ acknowledgments and channel state feedback, such as CQI, PMI, and/or RI) for aggregated cells may be transmitted on the PUCCH of the PCell. For a larger number of aggregated downlink CCs, the PUCCH of the PCell may become overloaded. Cells may be divided into multiple PUCCH groups.

[0137] FIG. 10B illustrates an example of how aggregated cells may be configured into one or more PUCCH groups. A PUCCH group 1010 and a PUCCH group 1050 may include one or more downlink CCs, respectively. In the example of FIG. 10B, the PUCCH group 1010 includes three downlink CCs: a PCell 1011, an SCell 1012, and an SCell 1013. The PUCCH group 1050 includes three downlink CCs in the present example: a PCell 1051, an SCell 1052, and an SCell 1053. One or more uplink CCs may be configured as a PCell 1021, an SCell 1022, and an SCell 1023. One or more other uplink CCs may be configured as a primary Scell (PSCell) 1061, an SCell 1062, and an SCell 1063. Uplink control information (UCI) related to the downlink CCs of the PUCCH group 1010, shown as UCI 1031, UCI 1032, and UCI 1033, may be transmitted in the uplink of the PCell 1021. Uplink control information (UCI) related to the downlink CCs of the PUCCH group 1050, shown as UCI 1071, UCI 1072, and UCI 1073, may be transmitted in the uplink of the PSCell 1061. In an example, if the aggregated cells depicted in FIG. 10B were not divided into the PUCCH group 1010 and the PUCCH group 1050, a single uplink PCell to transmit UCI relating to the downlink CCs, and the PCell may become overloaded. By dividing transmissions of UCI between the PCell 1021 and the PSCell 1061, overloading may be prevented.

[0138] A cell, comprising a downlink carrier and optionally an uplink carrier, may be assigned with a physical cell ID and a cell index. The physical cell ID or the cell index may identify a downlink carrier and/or an uplink carrier of the cell, for example, depending on the context in which the physical cell ID is used. A physical cell ID may be determined using a synchronization signal transmitted on a downlink component carrier. A cell index may be determined using RRC messages. In the disclosure, a physical cell ID may be referred to as a carrier ID, and a cell index may be referred to as a carrier index. For example, when the disclosure refers to a first physical cell ID for a first downlink carrier, the disclosure may mean the first physical cell ID is for a cell comprising the first downlink carrier. The same/similar concept may apply to, for example, a carrier activation. When the disclosure

indicates that a first carrier is activated, the specification may mean that a cell comprising the first carrier is activated.

- [0139]** In CA, a multi-carrier nature of a PHY may be exposed to a MAC. In an example, a HARQ entity may operate on a serving cell. A transport block may be generated per assignment/grant per serving cell. A transport block and potential HARQ retransmissions of the transport block may be mapped to a serving cell.
- [0140]** In the downlink, a base station may transmit (e.g., unicast, multicast, and/or broadcast) one or more Reference Signals (RSs) to a UE (e.g., PSS, SSS, CSI-RS, DMRS, and/or PT-RS, as shown in FIG. 5A). In the uplink, the UE may transmit one or more RSs to the base station (e.g., DMRS, PT-RS, and/or SRS, as shown in FIG. 5B). The PSS and the SSS may be transmitted by the base station and used by the UE to synchronize the UE to the base station. The PSS and the SSS may be provided in a synchronization signal (SS) / physical broadcast channel (PBCH) block that includes the PSS, the SSS, and the PBCH. The base station may periodically transmit a burst of SS/PBCH blocks.
- [0141]** FIG. 11A illustrates an example of an SS/PBCH block's structure and location. A burst of SS/PBCH blocks may include one or more SS/PBCH blocks (e.g., 4 SS/PBCH blocks, as shown in FIG. 11A). Bursts may be transmitted periodically (e.g., every 2 frames or 20 ms). A burst may be restricted to a half-frame (e.g., a first half-frame having a duration of 5 ms). It will be understood that FIG. 11A is an example, and that these parameters (number of SS/PBCH blocks per burst, periodicity of bursts, position of burst within the frame) may be configured based on, for example: a carrier frequency of a cell in which the SS/PBCH block is transmitted; a numerology or subcarrier spacing of the cell; a configuration by the network (e.g., using RRC signaling); or any other suitable factor. In an example, the UE may assume a subcarrier spacing for the SS/PBCH block based on the carrier frequency being monitored, unless the radio network configured the UE to assume a different subcarrier spacing.
- [0142]** The SS/PBCH block may span one or more OFDM symbols in the time domain (e.g., 4 OFDM symbols, as shown in the example of FIG. 11A) and may span one or more subcarriers in the frequency domain (e.g., 240 contiguous subcarriers). The PSS, the SSS, and the PBCH may have a common center frequency. The PSS may be transmitted first and may span, for example, 1 OFDM symbol and 127 subcarriers. The SSS may be transmitted after the PSS (e.g., two symbols later) and may span 1 OFDM symbol and 127 subcarriers. The PBCH may be transmitted after the PSS (e.g., across the next 3 OFDM symbols) and may span 240 subcarriers.

- [0143]** The location of the SS/PBCH block in the time and frequency domains may not be known to the UE (e.g., if the UE is searching for the cell). To find and select the cell, the UE may monitor a carrier for the PSS. For example, the UE may monitor a frequency location within the carrier. If the PSS is not found after a certain duration (e.g., 20 ms), the UE may search for the PSS at a different frequency location within the carrier, as indicated by a synchronization raster. If the PSS is found at a location in the time and frequency domains, the UE may determine, based on a known structure of the SS/PBCH block, the locations of the SSS and the PBCH, respectively. The SS/PBCH block may be a cell-defining SS block (CD-SSB). In an example, a primary cell may be associated with a CD-SSB. The CD-SSB may be located on a synchronization raster. In an example, a cell selection/search and/or reselection may be based on the CD-SSB.
- [0144]** The SS/PBCH block may be used by the UE to determine one or more parameters of the cell. For example, the UE may determine a physical cell identifier (PCI) of the cell based on the sequences of the PSS and the SSS, respectively. The UE may determine a location of a frame boundary of the cell based on the location of the SS/PBCH block. For example, the SS/PBCH block may indicate that it has been transmitted in accordance with a transmission pattern, wherein a SS/PBCH block in the transmission pattern is a known distance from the frame boundary.
- [0145]** The PBCH may use a QPSK modulation and may use forward error correction (FEC). The FEC may use polar coding. One or more symbols spanned by the PBCH may carry one or more DMRSs for demodulation of the PBCH. The PBCH may include an indication of a current system frame number (SFN) of the cell and/or a SS/PBCH block timing index. These parameters may facilitate time synchronization of the UE to the base station. The PBCH may include a master information block (MIB) used to provide the UE with one or more parameters. The MIB may be used by the UE to locate remaining minimum system information (RMSI) associated with the cell. The RMSI may include a System Information Block Type 1 (SIB1). The SIB1 may contain information needed by the UE to access the cell. The UE may use one or more parameters of the MIB to monitor PDCCH, which may be used to schedule PDSCH. The PDSCH may include the SIB1. The SIB1 may be decoded using parameters provided in the MIB. The PBCH may indicate an absence of SIB1. Based on the PBCH indicating the absence of SIB1, the UE may be pointed to a frequency. The UE may search for an SS/PBCH block at the frequency to which the UE is pointed.
- [0146]** The UE may assume that one or more SS/PBCH blocks transmitted with a same SS/PBCH block index are quasi co-located (QCLed) (e.g., having the same/similar Doppler spread, Doppler shift, average gain, average delay, and/or spatial Rx parameters). The UE

may not assume QCL for SS/PBCH block transmissions having different SS/PBCH block indices.

[0147] SS/PBCH blocks (e.g., those within a half-frame) may be transmitted in spatial directions (e.g., using different beams that span a coverage area of the cell). In an example, a first SS/PBCH block may be transmitted in a first spatial direction using a first beam, and a second SS/PBCH block may be transmitted in a second spatial direction using a second beam.

[0148] In an example, within a frequency span of a carrier, a base station may transmit a plurality of SS/PBCH blocks. In an example, a first PCI of a first SS/PBCH block of the plurality of SS/PBCH blocks may be different from a second PCI of a second SS/PBCH block of the plurality of SS/PBCH blocks. The PCIs of SS/PBCH blocks transmitted in different frequency locations may be different or the same.

[0149] The CSI-RS may be transmitted by the base station and used by the UE to acquire channel state information (CSI). The base station may configure the UE with one or more CSI-RSs for channel estimation or any other suitable purpose. The base station may configure a UE with one or more of the same/similar CSI-RSs. The UE may measure the one or more CSI-RSs. The UE may estimate a downlink channel state and/or generate a CSI report based on the measuring of the one or more downlink CSI-RSs. The UE may provide the CSI report to the base station. The base station may use feedback provided by the UE (e.g., the estimated downlink channel state) to perform link adaptation.

[0150] The base station may semi-statically configure the UE with one or more CSI-RS resource sets. A CSI-RS resource may be associated with a location in the time and frequency domains and a periodicity. The base station may selectively activate and/or deactivate a CSI-RS resource. The base station may indicate to the UE that a CSI-RS resource in the CSI-RS resource set is activated and/or deactivated.

[0151] The base station may configure the UE to report CSI measurements. The base station may configure the UE to provide CSI reports periodically, aperiodically, or semi-persistently. For periodic CSI reporting, the UE may be configured with a timing and/or periodicity of a plurality of CSI reports. For aperiodic CSI reporting, the base station may request a CSI report. For example, the base station may command the UE to measure a configured CSI-RS resource and provide a CSI report relating to the measurements. For semi-persistent CSI reporting, the base station may configure the UE to transmit periodically, and selectively activate or deactivate the periodic reporting. The base station may configure the UE with a CSI-RS resource set and CSI reports using RRC signaling.

- [0152]** The CSI-RS configuration may comprise one or more parameters indicating, for example, up to 32 antenna ports. The UE may be configured to employ the same OFDM symbols for a downlink CSI-RS and a control resource set (CORESET) when the downlink CSI-RS and CORESET are spatially QCLed and resource elements associated with the downlink CSI-RS are outside of the physical resource blocks (PRBs) configured for the CORESET. The UE may be configured to employ the same OFDM symbols for downlink CSI-RS and SS/PBCH blocks when the downlink CSI-RS and SS/PBCH blocks are spatially QCLed and resource elements associated with the downlink CSI-RS are outside of PRBs configured for the SS/PBCH blocks.
- [0153]** Downlink DMRSs may be transmitted by a base station and used by a UE for channel estimation. For example, the downlink DMRS may be used for coherent demodulation of one or more downlink physical channels (e.g., PDSCH). An NR network may support one or more variable and/or configurable DMRS patterns for data demodulation. At least one downlink DMRS configuration may support a front-loaded DMRS pattern. A front-loaded DMRS may be mapped over one or more OFDM symbols (e.g., one or two adjacent OFDM symbols). A base station may semi-statically configure the UE with a number (e.g. a maximum number) of front-loaded DMRS symbols for PDSCH. A DMRS configuration may support one or more DMRS ports. For example, for single user-MIMO, a DMRS configuration may support up to eight orthogonal downlink DMRS ports per UE. For multiuser-MIMO, a DMRS configuration may support up to 4 orthogonal downlink DMRS ports per UE. A radio network may support (e.g., at least for CP-OFDM) a common DMRS structure for downlink and uplink, wherein a DMRS location, a DMRS pattern, and/or a scrambling sequence may be the same or different. The base station may transmit a downlink DMRS and a corresponding PDSCH using the same precoding matrix. The UE may use the one or more downlink DMRSs for coherent demodulation/channel estimation of the PDSCH.
- [0154]** In an example, a transmitter (e.g., a base station) may use a precoder matrices for a part of a transmission bandwidth. For example, the transmitter may use a first precoder matrix for a first bandwidth and a second precoder matrix for a second bandwidth. The first precoder matrix and the second precoder matrix may be different based on the first bandwidth being different from the second bandwidth. The UE may assume that a same precoding matrix is used across a set of PRBs. The set of PRBs may be denoted as a precoding resource block group (PRG).
- [0155]** A PDSCH may comprise one or more layers. The UE may assume that at least one symbol with DMRS is present on a layer of the one or more layers of the PDSCH. A higher layer may configure up to 3 DMRSs for the PDSCH.

[0156] Downlink PT-RS may be transmitted by a base station and used by a UE for phase-noise compensation. Whether a downlink PT-RS is present or not may depend on an RRC configuration. The presence and/or pattern of the downlink PT-RS may be configured on a UE-specific basis using a combination of RRC signaling and/or an association with one or more parameters employed for other purposes (e.g., modulation and coding scheme (MCS)), which may be indicated by DCI. When configured, a dynamic presence of a downlink PT-RS may be associated with one or more DCI parameters comprising at least MCS. An NR network may support a plurality of PT-RS densities defined in the time and/or frequency domains. When present, a frequency domain density may be associated with at least one configuration of a scheduled bandwidth. The UE may assume a same precoding for a DMRS port and a PT-RS port. A number of PT-RS ports may be fewer than a number of DMRS ports in a scheduled resource. Downlink PT-RS may be confined in the scheduled time/frequency duration for the UE. Downlink PT-RS may be transmitted on symbols to facilitate phase tracking at the receiver.

[0157] The UE may transmit an uplink DMRS to a base station for channel estimation. For example, the base station may use the uplink DMRS for coherent demodulation of one or more uplink physical channels. For example, the UE may transmit an uplink DMRS with a PUSCH and/or a PUCCH. The uplink DM-RS may span a range of frequencies that is similar to a range of frequencies associated with the corresponding physical channel. The base station may configure the UE with one or more uplink DMRS configurations. At least one DMRS configuration may support a front-loaded DMRS pattern. The front-loaded DMRS may be mapped over one or more OFDM symbols (e.g., one or two adjacent OFDM symbols). One or more uplink DMRSs may be configured to transmit at one or more symbols of a PUSCH and/or a PUCCH. The base station may semi-statically configure the UE with a number (e.g. maximum number) of front-loaded DMRS symbols for the PUSCH and/or the PUCCH, which the UE may use to schedule a single-symbol DMRS and/or a double-symbol DMRS. An NR network may support (e.g., for cyclic prefix orthogonal frequency division multiplexing (CP-OFDM)) a common DMRS structure for downlink and uplink, wherein a DMRS location, a DMRS pattern, and/or a scrambling sequence for the DMRS may be the same or different.

[0158] A PUSCH may comprise one or more layers, and the UE may transmit at least one symbol with DMRS present on a layer of the one or more layers of the PUSCH. In an example, a higher layer may configure up to three DMRSs for the PUSCH.

[0159] Uplink PT-RS (which may be used by a base station for phase tracking and/or phase-noise compensation) may or may not be present depending on an RRC configuration of the

UE. The presence and/or pattern of uplink PT-RS may be configured on a UE-specific basis by a combination of RRC signaling and/or one or more parameters employed for other purposes (e.g., Modulation and Coding Scheme (MCS)), which may be indicated by DCI. When configured, a dynamic presence of uplink PT-RS may be associated with one or more DCI parameters comprising at least MCS. A radio network may support a plurality of uplink PT-RS densities defined in time/frequency domain. When present, a frequency domain density may be associated with at least one configuration of a scheduled bandwidth. The UE may assume a same precoding for a DMRS port and a PT-RS port. A number of PT-RS ports may be fewer than a number of DMRS ports in a scheduled resource. For example, uplink PT-RS may be confined in the scheduled time/frequency duration for the UE.

[0160] SRS may be transmitted by a UE to a base station for channel state estimation to support uplink channel dependent scheduling and/or link adaptation. SRS transmitted by the UE may allow a base station to estimate an uplink channel state at one or more frequencies. A scheduler at the base station may employ the estimated uplink channel state to assign one or more resource blocks for an uplink PUSCH transmission from the UE. The base station may semi-statically configure the UE with one or more SRS resource sets. For an SRS resource set, the base station may configure the UE with one or more SRS resources. An SRS resource set applicability may be configured by a higher layer (e.g., RRC) parameter. For example, when a higher layer parameter indicates beam management, an SRS resource in a SRS resource set of the one or more SRS resource sets (e.g., with the same/similar time domain behavior, periodic, aperiodic, and/or the like) may be transmitted at a time instant (e.g., simultaneously). The UE may transmit one or more SRS resources in SRS resource sets. An NR network may support aperiodic, periodic and/or semi-persistent SRS transmissions. The UE may transmit SRS resources based on one or more trigger types, wherein the one or more trigger types may comprise higher layer signaling (e.g., RRC) and/or one or more DCI formats. In an example, at least one DCI format may be employed for the UE to select at least one of one or more configured SRS resource sets. An SRS trigger type 0 may refer to an SRS triggered based on a higher layer signaling. An SRS trigger type 1 may refer to an SRS triggered based on one or more DCI formats. In an example, when PUSCH and SRS are transmitted in a same slot, the UE may be configured to transmit SRS after a transmission of a PUSCH and a corresponding uplink DMRS.

[0161] The base station may semi-statically configure the UE with one or more SRS configuration parameters indicating at least one of following: a SRS resource configuration identifier; a number of SRS ports; time domain behavior of an SRS resource configuration (e.g., an indication of periodic, semi-persistent, or aperiodic SRS); slot, mini-slot, and/or

subframe level periodicity; offset for a periodic and/or an aperiodic SRS resource; a number of OFDM symbols in an SRS resource; a starting OFDM symbol of an SRS resource; an SRS bandwidth; a frequency hopping bandwidth; a cyclic shift; and/or an SRS sequence ID.

[0162] An antenna port is defined such that the channel over which a symbol on the antenna port is conveyed can be inferred from the channel over which another symbol on the same antenna port is conveyed. If a first symbol and a second symbol are transmitted on the same antenna port, the receiver may infer the channel (e.g., fading gain, multipath delay, and/or the like) for conveying the second symbol on the antenna port, from the channel for conveying the first symbol on the antenna port. A first antenna port and a second antenna port may be referred to as quasi co-located (QCLed) if one or more large-scale properties of the channel over which a first symbol on the first antenna port is conveyed may be inferred from the channel over which a second symbol on a second antenna port is conveyed. The one or more large-scale properties may comprise at least one of: a delay spread; a Doppler spread; a Doppler shift; an average gain; an average delay; and/or spatial Receiving (Rx) parameters.

[0163] Channels that use beamforming require beam management. Beam management may comprise beam measurement, beam selection, and beam indication. A beam may be associated with one or more reference signals. For example, a beam may be identified by one or more beamformed reference signals. The UE may perform downlink beam measurement based on downlink reference signals (e.g., a channel state information reference signal (CSI-RS)) and generate a beam measurement report. The UE may perform the downlink beam measurement procedure after an RRC connection is set up with a base station.

[0164] FIG. 11B illustrates an example of channel state information reference signals (CSI-RSs) that are mapped in the time and frequency domains. A square shown in FIG. 11B may span a resource block (RB) within a bandwidth of a cell. A base station may transmit one or more RRC messages comprising CSI-RS resource configuration parameters indicating one or more CSI-RSs. One or more of the following parameters may be configured by higher layer signaling (e.g., RRC and/or MAC signaling) for a CSI-RS resource configuration: a CSI-RS resource configuration identity, a number of CSI-RS ports, a CSI-RS configuration (e.g., symbol and resource element (RE) locations in a subframe), a CSI-RS subframe configuration (e.g., subframe location, offset, and periodicity in a radio frame), a CSI-RS power parameter, a CSI-RS sequence parameter, a code division multiplexing (CDM) type parameter, a frequency density, a transmission comb, quasi co-location (QCL) parameters (e.g., QCL-scramblingidentity, crs-portscount, mbsfn-subframeconfiglist, csi-rs-configZPid, qcl-csi-rs-configNZPid), and/or other radio resource parameters.

[0165] The three beams illustrated in FIG. 11B may be configured for a UE in a UE-specific configuration. Three beams are illustrated in FIG. 11B (beam #1, beam #2, and beam #3), more or fewer beams may be configured. Beam #1 may be allocated with CSI-RS 1101 that may be transmitted in one or more subcarriers in an RB of a first symbol. Beam #2 may be allocated with CSI-RS 1102 that may be transmitted in one or more subcarriers in an RB of a second symbol. Beam #3 may be allocated with CSI-RS 1103 that may be transmitted in one or more subcarriers in an RB of a third symbol. By using frequency division multiplexing (FDM), a base station may use other subcarriers in a same RB (for example, those that are not used to transmit CSI-RS 1101) to transmit another CSI-RS associated with a beam for another UE. By using time domain multiplexing (TDM), beams used for the UE may be configured such that beams for the UE use symbols from beams of other UEs.

[0166] CSI-RSs such as those illustrated in FIG. 11B (e.g., CSI-RS 1101, 1102, 1103) may be transmitted by the base station and used by the UE for one or more measurements. For example, the UE may measure a reference signal received power (RSRP) of configured CSI-RS resources. The base station may configure the UE with a reporting configuration and the UE may report the RSRP measurements to a network (for example, via one or more base stations) based on the reporting configuration. In an example, the base station may determine, based on the reported measurement results, one or more transmission configuration indication (TCI) states comprising a number of reference signals. In an example, the base station may indicate one or more TCI states to the UE (e.g., via RRC signaling, a MAC CE, and/or a DCI). The UE may receive a downlink transmission with a receive (Rx) beam determined based on the one or more TCI states. In an example, the UE may or may not have a capability of beam correspondence. If the UE has the capability of beam correspondence, the UE may determine a spatial domain filter of a transmit (Tx) beam based on a spatial domain filter of the corresponding Rx beam. If the UE does not have the capability of beam correspondence, the UE may perform an uplink beam selection procedure to determine the spatial domain filter of the Tx beam. The UE may perform the uplink beam selection procedure based on one or more sounding reference signal (SRS) resources configured to the UE by the base station. The base station may select and indicate uplink beams for the UE based on measurements of the one or more SRS resources transmitted by the UE.

[0167] In a beam management procedure, a UE may assess (e.g., measure) a channel quality of one or more beam pair links, a beam pair link comprising a transmitting beam transmitted by a base station and a receiving beam received by the UE. Based on the assessment, the UE may transmit a beam measurement report indicating one or more beam pair quality

parameters comprising, e.g., one or more beam identifications (e.g., a beam index, a reference signal index, or the like), RSRP, a precoding matrix indicator (PMI), a channel quality indicator (CQI), and/or a rank indicator (RI).

[0168] FIG. 12A illustrates examples of three downlink beam management procedures: P1, P2, and P3. Procedure P1 may enable a UE measurement on transmit (Tx) beams of a transmission reception point (TRP) (or multiple TRPs), e.g., to support a selection of one or more base station Tx beams and/or UE Rx beams (shown as ovals in the top row and bottom row, respectively, of P1). Beamforming at a TRP may comprise a Tx beam sweep for a set of beams (shown, in the top rows of P1 and P2, as ovals rotated in a counter-clockwise direction indicated by the dashed arrow). Beamforming at a UE may comprise an Rx beam sweep for a set of beams (shown, in the bottom rows of P1 and P3, as ovals rotated in a clockwise direction indicated by the dashed arrow). Procedure P2 may be used to enable a UE measurement on Tx beams of a TRP (shown, in the top row of P2, as ovals rotated in a counter-clockwise direction indicated by the dashed arrow). The UE and/or the base station may perform procedure P2 using a smaller set of beams than is used in procedure P1, or using narrower beams than the beams used in procedure P1. This may be referred to as beam refinement. The UE may perform procedure P3 for Rx beam determination by using the same Tx beam at the base station and sweeping an Rx beam at the UE.

[0169] FIG. 12B illustrates examples of three uplink beam management procedures: U1, U2, and U3. Procedure U1 may be used to enable a base station to perform a measurement on Tx beams of a UE, e.g., to support a selection of one or more UE Tx beams and/or base station Rx beams (shown as ovals in the top row and bottom row, respectively, of U1). Beamforming at the UE may include, e.g., a Tx beam sweep from a set of beams (shown in the bottom rows of U1 and U3 as ovals rotated in a clockwise direction indicated by the dashed arrow). Beamforming at the base station may include, e.g., an Rx beam sweep from a set of beams (shown, in the top rows of U1 and U2, as ovals rotated in a counter-clockwise direction indicated by the dashed arrow). Procedure U2 may be used to enable the base station to adjust its Rx beam when the UE uses a fixed Tx beam. The UE and/or the base station may perform procedure U2 using a smaller set of beams than is used in procedure P1, or using narrower beams than the beams used in procedure P1. This may be referred to as beam refinement. The UE may perform procedure U3 to adjust its Tx beam when the base station uses a fixed Rx beam.

[0170] A UE may initiate a beam failure recovery (BFR) procedure based on detecting a beam failure. The UE may transmit a BFR request (e.g., a preamble, a UCI, an SR, a MAC CE, and/or the like) based on the initiating of the BFR procedure. The UE may detect the

beam failure based on a determination that a quality of beam pair link(s) of an associated control channel is unsatisfactory (e.g., having an error rate higher than an error rate threshold, a received signal power lower than a received signal power threshold, an expiration of a timer, and/or the like).

[0171] The UE may measure a quality of a beam pair link using one or more reference signals (RSs) comprising one or more SS/PBCH blocks, one or more CSI-RS resources, and/or one or more demodulation reference signals (DMRSs). A quality of the beam pair link may be based on one or more of a block error rate (BLER), an RSRP value, a signal to interference plus noise ratio (SINR) value, a reference signal received quality (RSRQ) value, and/or a CSI value measured on RS resources. The base station may indicate that an RS resource is quasi co-located (QCLed) with one or more DM-RSs of a channel (e.g., a control channel, a shared data channel, and/or the like). The RS resource and the one or more DMRSs of the channel may be QCLed when the channel characteristics (e.g., Doppler shift, Doppler spread, average delay, delay spread, spatial Rx parameter, fading, and/or the like) from a transmission via the RS resource to the UE are similar or the same as the channel characteristics from a transmission via the channel to the UE.

[0172] Random Access

[0173] A network (e.g., a gNB and/or an ng-eNB of a network) and/or the UE may initiate a random access procedure. A UE in an RRC_IDLE state and/or an RRC_INACTIVE state may initiate the random access procedure to request a connection setup to a network. The UE may initiate the random access procedure from an RRC_CONNECTED state. The UE may initiate the random access procedure to request uplink resources (e.g., for uplink transmission of an SR when there is no PUCCH resource available) and/or acquire uplink timing (e.g., when uplink synchronization status is non-synchronized). The UE may initiate the random access procedure to request one or more system information blocks (SIBs) (e.g., other system information such as SIB2, SIB3, and/or the like). The UE may initiate the random access procedure for a beam failure recovery request. A network may initiate a random access procedure for a handover and/or for establishing time alignment for an SCell addition.

[0174] FIG. 13A illustrates a four-step contention-based random access procedure. Prior to initiation of the procedure, a base station may transmit a configuration message 1310 to the UE. The procedure illustrated in FIG. 13A comprises transmission of four messages: a Msg 1 1311, a Msg 2 1312, a Msg 3 1313, and a Msg 4 1314. The Msg 1 1311 may include and/or be referred to as a preamble (or a random access preamble). The Msg 2 1312 may include and/or be referred to as a random access response (RAR).

[0175] The configuration message 1310 may be transmitted, for example, using one or more RRC messages. The one or more RRC messages may indicate one or more random access channel (RACH) parameters to the UE. The one or more RACH parameters may comprise at least one of following: general parameters for one or more random access procedures (e.g., RACH-configGeneral); cell-specific parameters (e.g., RACH-ConfigCommon); and/or dedicated parameters (e.g., RACH-configDedicated). The base station may broadcast or multicast the one or more RRC messages to one or more UEs. The one or more RRC messages may be UE-specific (e.g., dedicated RRC messages transmitted to a UE in an RRC_CONNECTED state and/or in an RRC_INACTIVE state). The UE may determine, based on the one or more RACH parameters, a time-frequency resource and/or an uplink transmit power for transmission of the Msg 1 1311 and/or the Msg 3 1313. Based on the one or more RACH parameters, the UE may determine a reception timing and a downlink channel for receiving the Msg 2 1312 and the Msg 4 1314.

[0176] The one or more RACH parameters provided in the configuration message 1310 may indicate one or more Physical RACH (PRACH) occasions available for transmission of the Msg 1 1311. The one or more PRACH occasions may be predefined. The one or more RACH parameters may indicate one or more available sets of one or more PRACH occasions (e.g., prach-ConfigIndex). The one or more RACH parameters may indicate an association between (a) one or more PRACH occasions and (b) one or more reference signals. The one or more RACH parameters may indicate an association between (a) one or more preambles and (b) one or more reference signals. The one or more reference signals may be SS/PBCH blocks and/or CSI-RSs. For example, the one or more RACH parameters may indicate a number of SS/PBCH blocks mapped to a PRACH occasion and/or a number of preambles mapped to a SS/PBCH blocks.

[0177] The one or more RACH parameters provided in the configuration message 1310 may be used to determine an uplink transmit power of Msg 1 1311 and/or Msg 3 1313. For example, the one or more RACH parameters may indicate a reference power for a preamble transmission (e.g., a received target power and/or an initial power of the preamble transmission). There may be one or more power offsets indicated by the one or more RACH parameters. For example, the one or more RACH parameters may indicate: a power ramping step; a power offset between SSB and CSI-RS; a power offset between transmissions of the Msg 1 1311 and the Msg 3 1313; and/or a power offset value between preamble groups. The one or more RACH parameters may indicate one or more thresholds based on which the UE may determine at least one reference signal (e.g., an SSB and/or CSI-RS) and/or an uplink carrier (e.g., a normal uplink (NUL) carrier and/or a supplemental uplink (SUL) carrier).

[0178] The Msg 1 1311 may include one or more preamble transmissions (e.g., a preamble transmission and one or more preamble retransmissions). An RRC message may be used to configure one or more preamble groups (e.g., group A and/or group B). A preamble group may comprise one or more preambles. The UE may determine the preamble group based on a pathloss measurement and/or a size of the Msg 3 1313. The UE may measure an RSRP of one or more reference signals (e.g., SSBs and/or CSI-RSs) and determine at least one reference signal having an RSRP above an RSRP threshold (e.g., *rsrp-ThresholdSSB* and/or *rsrp-ThresholdCSI-RS*). The UE may select at least one preamble associated with the one or more reference signals and/or a selected preamble group, for example, if the association between the one or more preambles and the at least one reference signal is configured by an RRC message.

[0179] The UE may determine the preamble based on the one or more RACH parameters provided in the configuration message 1310. For example, the UE may determine the preamble based on a pathloss measurement, an RSRP measurement, and/or a size of the Msg 3 1313. As another example, the one or more RACH parameters may indicate: a preamble format; a maximum number of preamble transmissions; and/or one or more thresholds for determining one or more preamble groups (e.g., group A and group B). A base station may use the one or more RACH parameters to configure the UE with an association between one or more preambles and one or more reference signals (e.g., SSBs and/or CSI-RSs). If the association is configured, the UE may determine the preamble to include in Msg 1 1311 based on the association. The Msg 1 1311 may be transmitted to the base station via one or more PRACH occasions. The UE may use one or more reference signals (e.g., SSBs and/or CSI-RSs) for selection of the preamble and for determining of the PRACH occasion. One or more RACH parameters (e.g., *ra-ssb-OccasionMskIndex* and/or *ra-OccasionList*) may indicate an association between the PRACH occasions and the one or more reference signals.

[0180] The UE may perform a preamble retransmission if no response is received following a preamble transmission. The UE may increase an uplink transmit power for the preamble retransmission. The UE may select an initial preamble transmit power based on a pathloss measurement and/or a target received preamble power configured by the network. The UE may determine to retransmit a preamble and may ramp up the uplink transmit power. The UE may receive one or more RACH parameters (e.g., *PREAMBLE_POWER_RAMPING_STEP*) indicating a ramping step for the preamble retransmission. The ramping step may be an amount of incremental increase in uplink transmit power for a retransmission. The UE may ramp up the uplink transmit power if the UE determines a reference signal (e.g., SSB and/or CSI-RS) that is the same as a previous

preamble transmission. The UE may count a number of preamble transmissions and/or retransmissions (e.g., PREAMBLE_TRANSMISSION_COUNTER). The UE may determine that a random access procedure completed unsuccessfully, for example, if the number of preamble transmissions exceeds a threshold configured by the one or more RACH parameters (e.g., preambleTransMax).

[0181] The Msg 2 1312 received by the UE may include an RAR. In some scenarios, the Msg 2 1312 may include multiple RARs corresponding to multiple UEs. The Msg 2 1312 may be received after or in response to the transmitting of the Msg 1 1311. The Msg 2 1312 may be scheduled on the DL-SCH and indicated on a PDCCH using a random access RNTI (RA-RNTI). The Msg 2 1312 may indicate that the Msg 1 1311 was received by the base station. The Msg 2 1312 may include a time-alignment command that may be used by the UE to adjust the UE's transmission timing, a scheduling grant for transmission of the Msg 3 1313, and/or a Temporary Cell RNTI (TC-RNTI). After transmitting a preamble, the UE may start a time window (e.g., ra-ResponseWindow) to monitor a PDCCH for the Msg 2 1312. The UE may determine when to start the time window based on a PRACH occasion that the UE uses to transmit the preamble. For example, the UE may start the time window one or more symbols after a last symbol of the preamble (e.g., at a first PDCCH occasion from an end of a preamble transmission). The one or more symbols may be determined based on a numerology. The PDCCH may be in a common search space (e.g., a Type1-PDCCH common search space) configured by an RRC message. The UE may identify the RAR based on a Radio Network Temporary Identifier (RNTI). RNTIs may be used depending on one or more events initiating the random access procedure. The UE may use random access RNTI (RA-RNTI). The RA-RNTI may be associated with PRACH occasions in which the UE transmits a preamble. For example, the UE may determine the RA-RNTI based on: an OFDM symbol index; a slot index; a frequency domain index; and/or a UL carrier indicator of the PRACH occasions. An example of RA-RNTI may be as follows:

$$\text{RA-RNTI} = 1 + s_id + 14 \times t_id + 14 \times 80 \times f_id + 14 \times 80 \times 8 \times ul_carrier_id$$

where s_id may be an index of a first OFDM symbol of the PRACH occasion (e.g., $0 \leq s_id < 14$), t_id may be an index of a first slot of the PRACH occasion in a system frame (e.g., $0 \leq t_id < 80$), f_id may be an index of the PRACH occasion in the frequency domain (e.g., $0 \leq f_id < 8$), and $ul_carrier_id$ may be a UL carrier used for a preamble transmission (e.g., 0 for an NUL carrier, and 1 for an SUL carrier).

The UE may transmit the Msg 3 1313 in response to a successful reception of the Msg 2 1312 (e.g., using resources identified in the Msg 2 1312). The Msg 3 1313 may be used for contention resolution in, for example, the contention-based random access procedure

illustrated in FIG. 13A. In some scenarios, a plurality of UEs may transmit a same preamble to a base station and the base station may provide an RAR that corresponds to a UE.

Collisions may occur if the plurality of UEs interpret the RAR as corresponding to themselves. Contention resolution (e.g., using the Msg 3 1313 and the Msg 4 1314) may be used to increase the likelihood that the UE does not incorrectly use an identity of another the UE. To perform contention resolution, the UE may include a device identifier in the Msg 3 1313 (e.g., a C-RNTI if assigned, a TC-RNTI included in the Msg 2 1312, and/or any other suitable identifier).

[0182] The Msg 4 1314 may be received after or in response to the transmitting of the Msg 3 1313. If a C-RNTI was included in the Msg 3 1313, the base station will address the UE on the PDCCH using the C-RNTI. If the UE's unique C-RNTI is detected on the PDCCH, the random access procedure is determined to be successfully completed. If a TC-RNTI is included in the Msg 3 1313 (e.g., if the UE is in an RRC_IDLE state or not otherwise connected to the base station), Msg 4 1314 will be received using a DL-SCH associated with the TC-RNTI. If a MAC PDU is successfully decoded and a MAC PDU comprises the UE contention resolution identity MAC CE that matches or otherwise corresponds with the CCCH SDU sent (e.g., transmitted) in Msg 3 1313, the UE may determine that the contention resolution is successful and/or the UE may determine that the random access procedure is successfully completed.

[0183] The UE may be configured with a supplementary uplink (SUL) carrier and a normal uplink (NUL) carrier. An initial access (e.g., random access procedure) may be supported in an uplink carrier. For example, a base station may configure the UE with two separate RACH configurations: one for an SUL carrier and the other for an NUL carrier. For random access in a cell configured with an SUL carrier, the network may indicate which carrier to use (NUL or SUL). The UE may determine the SUL carrier, for example, if a measured quality of one or more reference signals is lower than a broadcast threshold. Uplink transmissions of the random access procedure (e.g., the Msg 1 1311 and/or the Msg 3 1313) may remain on the selected carrier. The UE may switch an uplink carrier during the random access procedure (e.g., between the Msg 1 1311 and the Msg 3 1313) in one or more cases. For example, the UE may determine and/or switch an uplink carrier for the Msg 1 1311 and/or the Msg 3 1313 based on a channel clear assessment (e.g., a listen-before-talk).

[0184] FIG. 13B illustrates a two-step contention-free random access procedure. Similar to the four-step contention-based random access procedure illustrated in FIG. 13A, a base station may, prior to initiation of the procedure, transmit a configuration message 1320 to the UE. The configuration message 1320 may be analogous in some respects to the configuration

message 1310. The procedure illustrated in FIG. 13B comprises transmission of two messages: a Msg 1 1321 and a Msg 2 1322. The Msg 1 1321 and the Msg 2 1322 may be analogous in some respects to the Msg 1 1311 and a Msg 2 1312 illustrated in FIG. 13A, respectively. As will be understood from FIGS. 13A and 13B, the contention-free random access procedure may not include messages analogous to the Msg 3 1313 and/or the Msg 4 1314.

[0185] The contention-free random access procedure illustrated in FIG. 13B may be initiated for a beam failure recovery, other SI request, SCell addition, and/or handover. For example, a base station may indicate or assign to the UE the preamble to be used for the Msg 1 1321. The UE may receive, from the base station via PDCCH and/or RRC, an indication of a preamble (e.g., ra-PreambleIndex).

[0186] After transmitting a preamble, the UE may start a time window (e.g., ra-ResponseWindow) to monitor a PDCCH for the RAR. In the event of a beam failure recovery request, the base station may configure the UE with a separate time window and/or a separate PDCCH in a search space indicated by an RRC message (e.g., recoverySearchSpaceId). The UE may monitor for a PDCCH transmission addressed to a Cell RNTI (C-RNTI) on the search space. In the contention-free random access procedure illustrated in FIG. 13B, the UE may determine that a random access procedure successfully completes after or in response to transmission of Msg 1 1321 and reception of a corresponding Msg 2 1322. The UE may determine that a random access procedure successfully completes, for example, if a PDCCH transmission is addressed to a C-RNTI. The UE may determine that a random access procedure successfully completes, for example, if the UE receives an RAR comprising a preamble identifier corresponding to a preamble transmitted by the UE and/or the RAR comprises a MAC sub-PDU with the preamble identifier. The UE may determine the response as an indication of an acknowledgement for an SI request.

[0187] FIG. 13C illustrates another two-step random access procedure. Similar to the random access procedures illustrated in FIGS. 13A and 13B, a base station may, prior to initiation of the procedure, transmit a configuration message 1330 to the UE. The configuration message 1330 may be analogous in some respects to the configuration message 1310 and/or the configuration message 1320. The procedure illustrated in FIG. 13C comprises transmission of two messages: a Msg A 1331 and a Msg B 1332.

[0188] Msg A 1331 may be transmitted in an uplink transmission by the UE. Msg A 1331 may comprise one or more transmissions of a preamble 1341 and/or one or more transmissions of a transport block 1342. The transport block 1342 may comprise contents

that are similar and/or equivalent to the contents of the Msg 3 1313 illustrated in FIG. 13A. The transport block 1342 may comprise UCI (e.g., an SR, a HARQ ACK/NACK, and/or the like). The UE may receive the Msg B 1332 after or in response to transmitting the Msg A 1331. The Msg B 1332 may comprise contents that are similar and/or equivalent to the contents of the Msg 2 1312 (e.g., an RAR) illustrated in FIGS. 13A and 13B and/or the Msg 4 1314 illustrated in FIG. 13A.

[0189] The UE may initiate the two-step random access procedure in FIG. 13C for licensed spectrum and/or unlicensed spectrum. The UE may determine, based on one or more factors, whether to initiate the two-step random access procedure. The one or more factors may be: a radio access technology in use (e.g., LTE, NR, and/or the like); whether the UE has valid TA or not; a cell size; the UE's RRC state; a type of spectrum (e.g., licensed vs. unlicensed); and/or any other suitable factors.

[0190] The UE may determine, based on two-step RACH parameters included in the configuration message 1330, a radio resource and/or an uplink transmit power for the preamble 1341 and/or the transport block 1342 included in the Msg A 1331. The RACH parameters may indicate a modulation and coding schemes (MCS), a time-frequency resource, and/or a power control for the preamble 1341 and/or the transport block 1342. A time-frequency resource for transmission of the preamble 1341 (e.g., a PRACH) and a time-frequency resource for transmission of the transport block 1342 (e.g., a PUSCH) may be multiplexed using FDM, TDM, and/or CDM. The RACH parameters may enable the UE to determine a reception timing and a downlink channel for monitoring for and/or receiving Msg B 1332.

[0191] The transport block 1342 may comprise data (e.g., delay-sensitive data), an identifier of the UE, security information, and/or device information (e.g., an International Mobile Subscriber Identity (IMSI)). The base station may transmit the Msg B 1332 as a response to the Msg A 1331. The Msg B 1332 may comprise at least one of following: a preamble identifier; a timing advance command; a power control command; an uplink grant (e.g., a radio resource assignment and/or an MCS); a UE identifier for contention resolution; and/or an RNTI (e.g., a C-RNTI or a TC-RNTI). The UE may determine that the two-step random access procedure is successfully completed if: a preamble identifier in the Msg B 1332 is matched to a preamble transmitted by the UE; and/or the identifier of the UE in Msg B 1332 is matched to the identifier of the UE in the Msg A 1331 (e.g., the transport block 1342).

[0192] A UE and a base station may exchange control signaling. The control signaling may be referred to as L1/L2 control signaling and may originate from the PHY layer (e.g., layer 1) and/or the MAC layer (e.g., layer 2). The control signaling may comprise downlink control

signaling transmitted from the base station to the UE and/or uplink control signaling transmitted from the UE to the base station.

[0193] The downlink control signaling may comprise: a downlink scheduling assignment; an uplink scheduling grant indicating uplink radio resources and/or a transport format; a slot format information; a preemption indication; a power control command; and/or any other suitable signaling. The UE may receive the downlink control signaling in a payload transmitted by the base station on a physical downlink control channel (PDCCH). The payload transmitted on the PDCCH may be referred to as downlink control information (DCI). In some scenarios, the PDCCH may be a group common PDCCH (GC-PDCCH) that is common to a group of UEs.

[0194] A base station may attach one or more cyclic redundancy check (CRC) parity bits to a DCI in order to facilitate detection of transmission errors. When the DCI is intended for a UE (or a group of the UEs), the base station may scramble the CRC parity bits with an identifier of the UE (or an identifier of the group of the UEs). Scrambling the CRC parity bits with the identifier may comprise Modulo-2 addition (or an exclusive OR operation) of the identifier value and the CRC parity bits. The identifier may comprise a 16-bit value of a radio network temporary identifier (RNTI).

[0195] DCIs may be used for different purposes. A purpose may be indicated by the type of RNTI used to scramble the CRC parity bits. For example, a DCI having CRC parity bits scrambled with a paging RNTI (P-RNTI) may indicate paging information and/or a system information change notification. The P-RNTI may be predefined as "FFFE" in hexadecimal. A DCI having CRC parity bits scrambled with a system information RNTI (SI-RNTI) may indicate a broadcast transmission of the system information. The SI-RNTI may be predefined as "FFFF" in hexadecimal. A DCI having CRC parity bits scrambled with a random access RNTI (RA-RNTI) may indicate a random access response (RAR). A DCI having CRC parity bits scrambled with a cell RNTI (C-RNTI) may indicate a dynamically scheduled unicast transmission and/or a triggering of PDCCH-ordered random access. A DCI having CRC parity bits scrambled with a temporary cell RNTI (TC-RNTI) may indicate a contention resolution (e.g., a Msg 3 analogous to the Msg 3 1313 illustrated in FIG. 13A). Other RNTIs configured to the UE by a base station may comprise a Configured Scheduling RNTI (CS-RNTI), a Transmit Power Control-PUCCH RNTI (TPC-PUCCH-RNTI), a Transmit Power Control-PUSCH RNTI (TPC-PUSCH-RNTI), a Transmit Power Control-SRS RNTI (TPC-SRS-RNTI), an Interruption RNTI (INT-RNTI), a Slot Format Indication RNTI (SFI-RNTI), a Semi-Persistent CSI RNTI (SP-CSI-RNTI), a Modulation and Coding Scheme Cell RNTI (MCS-C-RNTI), and/or the like.

[0196] Depending on the purpose and/or content of a DCI, the base station may transmit the DCIs with one or more DCI formats. For example, DCI format 0_0 may be used for scheduling of PUSCH in a cell. DCI format 0_0 may be a fallback DCI format (e.g., with compact DCI payloads). DCI format 0_1 may be used for scheduling of PUSCH in a cell (e.g., with more DCI payloads than DCI format 0_0). DCI format 1_0 may be used for scheduling of PDSCH in a cell. DCI format 1_0 may be a fallback DCI format (e.g., with compact DCI payloads). DCI format 1_1 may be used for scheduling of PDSCH in a cell (e.g., with more DCI payloads than DCI format 1_0). DCI format 2_0 may be used for providing a slot format indication to a group of UEs. DCI format 2_1 may be used for notifying a group of UEs of a physical resource block and/or OFDM symbol where the UE may assume no transmission is intended to the UE. DCI format 2_2 may be used for transmission of a transmit power control (TPC) command for PUCCH or PUSCH. DCI format 2_3 may be used for transmission of a group of TPC commands for SRS transmissions by one or more UEs. DCI format(s) for new functions may be defined in future releases. DCI formats may have different DCI sizes, or may share the same DCI size.

[0197] After scrambling a DCI with a RNTI, the base station may process the DCI with channel coding (e.g., polar coding), rate matching, scrambling and/or QPSK modulation. A base station may map the coded and modulated DCI on resource elements used and/or configured for a PDCCH. Based on a payload size of the DCI and/or a coverage of the base station, the base station may transmit the DCI via a PDCCH occupying a number of contiguous control channel elements (CCEs). The number of the contiguous CCEs (referred to as aggregation level) may be 1, 2, 4, 8, 16, and/or any other suitable number. A CCE may comprise a number (e.g., 6) of resource-element groups (REGs). A REG may comprise a resource block in an OFDM symbol. The mapping of the coded and modulated DCI on the resource elements may be based on mapping of CCEs and REGs (e.g., CCE-to-REG mapping).

[0198] FIG. 14A illustrates an example of CORESET configurations for a bandwidth part. The base station may transmit a DCI via a PDCCH on one or more control resource sets (CORESETs). A CORESET may comprise a time-frequency resource in which the UE tries to decode a DCI using one or more search spaces. The base station may configure a CORESET in the time-frequency domain. In the example of FIG. 14A, a first CORESET 1401 and a second CORESET 1402 occur at the first symbol in a slot. The first CORESET 1401 overlaps with the second CORESET 1402 in the frequency domain. A third CORESET 1403 occurs at a third symbol in the slot. A fourth CORESET 1404 occurs at the seventh

symbol in the slot. CORESETs may have a different number of resource blocks in frequency domain.

[0199] FIG. 14B illustrates an example of a CCE-to-REG mapping for DCI transmission on a CORESET and PDCCH processing. The CCE-to-REG mapping may be an interleaved mapping (e.g., for the purpose of providing frequency diversity) or a non-interleaved mapping (e.g., for the purposes of facilitating interference coordination and/or frequency-selective transmission of control channels). The base station may perform different or same CCE-to-REG mapping on different CORESETs. A CORESET may be associated with a CCE-to-REG mapping by RRC configuration. A CORESET may be configured with an antenna port quasi co-location (QCL) parameter. The antenna port QCL parameter may indicate QCL information of a demodulation reference signal (DMRS) for PDCCH reception in the CORESET.

[0200] The base station may transmit, to the UE, RRC messages comprising configuration parameters of one or more CORESETs and one or more search space sets. The configuration parameters may indicate an association between a search space set and a CORESET. A search space set may comprise a set of PDCCH candidates formed by CCEs at a given aggregation level. The configuration parameters may indicate: a number of PDCCH candidates to be monitored per aggregation level; a PDCCH monitoring periodicity and a PDCCH monitoring pattern; one or more DCI formats to be monitored by the UE; and/or whether a search space set is a common search space set or a UE-specific search space set. A set of CCEs in the common search space set may be predefined and known to the UE. A set of CCEs in the UE-specific search space set may be configured based on the UE's identity (e.g., C-RNTI).

[0201] As shown in FIG. 14B, the UE may determine a time-frequency resource for a CORESET based on RRC messages. The UE may determine a CCE-to-REG mapping (e.g., interleaved or non-interleaved, and/or mapping parameters) for the CORESET based on configuration parameters of the CORESET. The UE may determine a number (e.g., at most 10) of search space sets configured on the CORESET based on the RRC messages. The UE may monitor a set of PDCCH candidates according to configuration parameters of a search space set. The UE may monitor a set of PDCCH candidates in one or more CORESETs for detecting one or more DCIs. Monitoring may comprise decoding one or more PDCCH candidates of the set of the PDCCH candidates according to the monitored DCI formats. Monitoring may comprise decoding a DCI content of one or more PDCCH candidates with possible (or configured) PDCCH locations, possible (or configured) PDCCH formats (e.g., number of CCEs, number of PDCCH candidates in common search spaces, and/or number of

PDCCH candidates in the UE-specific search spaces) and possible (or configured) DCI formats. The decoding may be referred to as blind decoding. The UE may determine a DCI as valid for the UE, in response to CRC checking (e.g., scrambled bits for CRC parity bits of the DCI matching a RNTI value). The UE may process information contained in the DCI (e.g., a scheduling assignment, an uplink grant, power control, a slot format indication, a downlink preemption, and/or the like).

[0202] The UE may transmit uplink control signaling (e.g., uplink control information (UCI)) to a base station. The uplink control signaling may comprise hybrid automatic repeat request (HARQ) acknowledgements for received DL-SCH transport blocks. The UE may transmit the HARQ acknowledgements after receiving a DL-SCH transport block. Uplink control signaling may comprise channel state information (CSI) indicating channel quality of a physical downlink channel. The UE may transmit the CSI to the base station. The base station, based on the received CSI, may determine transmission format parameters (e.g., comprising multi-antenna and beamforming schemes) for a downlink transmission. Uplink control signaling may comprise scheduling requests (SR). The UE may transmit an SR indicating that uplink data is available for transmission to the base station. The UE may transmit a UCI (e.g., HARQ acknowledgements (HARQ-ACK), CSI report, SR, and the like) via a physical uplink control channel (PUCCH) or a physical uplink shared channel (PUSCH). The UE may transmit the uplink control signaling via a PUCCH using one of several PUCCH formats.

[0203] There may be five PUCCH formats and the UE may determine a PUCCH format based on a size of the UCI (e.g., a number of uplink symbols of UCI transmission and a number of UCI bits). PUCCH format 0 may have a length of one or two OFDM symbols and may include two or fewer bits. The UE may transmit UCI in a PUCCH resource using PUCCH format 0 if the transmission is over one or two symbols and the number of HARQ-ACK information bits with positive or negative SR (HARQ-ACK/SR bits) is one or two. PUCCH format 1 may occupy a number between four and fourteen OFDM symbols and may include two or fewer bits. The UE may use PUCCH format 1 if the transmission is four or more symbols and the number of HARQ-ACK/SR bits is one or two. PUCCH format 2 may occupy one or two OFDM symbols and may include more than two bits. The UE may use PUCCH format 2 if the transmission is over one or two symbols and the number of UCI bits is two or more. PUCCH format 3 may occupy a number between four and fourteen OFDM symbols and may include more than two bits. The UE may use PUCCH format 3 if the transmission is four or more symbols, the number of UCI bits is two or more and PUCCH resource does not include an orthogonal cover code. PUCCH format 4 may occupy a number

between four and fourteen OFDM symbols and may include more than two bits. The UE may use PUCCH format 4 if the transmission is four or more symbols, the number of UCI bits is two or more and the PUCCH resource includes an orthogonal cover code.

[0204] The base station may transmit configuration parameters to the UE for a plurality of PUCCH resource sets using, for example, an RRC message. The plurality of PUCCH resource sets (e.g., up to four sets) may be configured on an uplink BWP of a cell. A PUCCH resource set may be configured with a PUCCH resource set index, a plurality of PUCCH resources with a PUCCH resource being identified by a PUCCH resource identifier (e.g., pucch-Resourceid), and/or a number (e.g. a maximum number) of UCI information bits the UE may transmit using one of the plurality of PUCCH resources in the PUCCH resource set. When configured with a plurality of PUCCH resource sets, the UE may select one of the plurality of PUCCH resource sets based on a total bit length of the UCI information bits (e.g., HARQ-ACK, SR, and/or CSI). If the total bit length of UCI information bits is two or fewer, the UE may select a first PUCCH resource set having a PUCCH resource set index equal to “0”. If the total bit length of UCI information bits is greater than two and less than or equal to a first configured value, the UE may select a second PUCCH resource set having a PUCCH resource set index equal to “1”. If the total bit length of UCI information bits is greater than the first configured value and less than or equal to a second configured value, the UE may select a third PUCCH resource set having a PUCCH resource set index equal to “2”. If the total bit length of UCI information bits is greater than the second configured value and less than or equal to a third value (e.g., 1406), the UE may select a fourth PUCCH resource set having a PUCCH resource set index equal to “3”.

[0205] After determining a PUCCH resource set from a plurality of PUCCH resource sets, the UE may determine a PUCCH resource from the PUCCH resource set for UCI (HARQ-ACK, CSI, and/or SR) transmission. The UE may determine the PUCCH resource based on a PUCCH resource indicator in a DCI (e.g., with a DCI format 1_0 or DCI for 1_1) received on a PDCCH. A three-bit PUCCH resource indicator in the DCI may indicate one of eight PUCCH resources in the PUCCH resource set. Based on the PUCCH resource indicator, the UE may transmit the UCI (HARQ-ACK, CSI and/or SR) using a PUCCH resource indicated by the PUCCH resource indicator in the DCI.

[0206] FIG. 15 illustrates an example of a wireless device 1502 in communication with a base station 1504 in accordance with embodiments of the present disclosure. The wireless device 1502 and base station 1504 may be part of a mobile communication network, such as the mobile communication network 100 illustrated in FIG. 1A, the mobile communication network 150 illustrated in FIG. 1B, or any other communication network. Only one wireless

device 1502 and one base station 1504 are illustrated in FIG. 15, but it will be understood that a mobile communication network may include more than one UE and/or more than one base station, with the same or similar configuration as those shown in FIG. 15.

[0207] The base station 1504 may connect the wireless device 1502 to a core network (not shown) through radio communications over the air interface (or radio interface) 1506. The communication direction from the base station 1504 to the wireless device 1502 over the air interface 1506 is known as the downlink, and the communication direction from the wireless device 1502 to the base station 1504 over the air interface is known as the uplink. Downlink transmissions may be separated from uplink transmissions using FDD, TDD, and/or some combination of the two duplexing techniques.

[0208] In the downlink, data to be sent to the wireless device 1502 from the base station 1504 may be provided to the processing system 1508 of the base station 1504. The data may be provided to the processing system 1508 by, for example, a core network. In the uplink, data to be sent to the base station 1504 from the wireless device 1502 may be provided to the processing system 1518 of the wireless device 1502. The processing system 1508 and the processing system 1518 may implement layer 3 and layer 2 OSI functionality to process the data for transmission. Layer 2 may include an SDAP layer, a PDCP layer, an RLC layer, and a MAC layer, for example, with respect to FIG. 2A, FIG. 2B, FIG. 3, and FIG. 4A. Layer 3 may include an RRC layer as with respect to FIG. 2B.

[0209] After being processed by processing system 1508, the data to be sent to the wireless device 1502 may be provided to a transmission processing system 1510 of base station 1504. Similarly, after being processed by the processing system 1518, the data to be sent to base station 1504 may be provided to a transmission processing system 1520 of the wireless device 1502. The transmission processing system 1510 and the transmission processing system 1520 may implement layer 1 OSI functionality. Layer 1 may include a PHY layer with respect to FIG. 2A, FIG. 2B, FIG. 3, and FIG. 4A. For transmit processing, the PHY layer may perform, for example, forward error correction coding of transport channels, interleaving, rate matching, mapping of transport channels to physical channels, modulation of physical channel, multiple-input multiple-output (MIMO) or multi-antenna processing, and/or the like.

[0210] At the base station 1504, a reception processing system 1512 may receive the uplink transmission from the wireless device 1502. At the wireless device 1502, a reception processing system 1522 may receive the downlink transmission from base station 1504. The reception processing system 1512 and the reception processing system 1522 may implement layer 1 OSI functionality. Layer 1 may include a PHY layer with respect to FIG. 2A, FIG.

2B, FIG. 3, and FIG. 4A. For receive processing, the PHY layer may perform, for example, error detection, forward error correction decoding, deinterleaving, demapping of transport channels to physical channels, demodulation of physical channels, MIMO or multi-antenna processing, and/or the like.

[0211] As shown in FIG. 15, a wireless device 1502 and the base station 1504 may include multiple antennas. The multiple antennas may be used to perform one or more MIMO or multi-antenna techniques, such as spatial multiplexing (e.g., single-user MIMO or multi-user MIMO), transmit/receive diversity, and/or beamforming. In other examples, the wireless device 1502 and/or the base station 1504 may have a single antenna.

[0212] The processing system 1508 and the processing system 1518 may be associated with a memory 1514 and a memory 1524, respectively. Memory 1514 and memory 1524 (e.g., one or more non-transitory computer readable mediums) may store computer program instructions or code that may be executed by the processing system 1508 and/or the processing system 1518 to carry out one or more of the functionalities discussed in the present application. Although not shown in FIG. 15, the transmission processing system 1510, the transmission processing system 1520, the reception processing system 1512, and/or the reception processing system 1522 may be coupled to a memory (e.g., one or more non-transitory computer readable mediums) storing computer program instructions or code that may be executed to carry out one or more of their respective functionalities.

[0213] The processing system 1508 and/or the processing system 1518 may comprise one or more controllers and/or one or more processors. The one or more controllers and/or one or more processors may comprise, for example, a general-purpose processor, a digital signal processor (DSP), a microcontroller, an application specific integrated circuit (ASIC), a field programmable gate array (FPGA) and/or other programmable logic device, discrete gate and/or transistor logic, discrete hardware components, an on-board unit, or any combination thereof. The processing system 1508 and/or the processing system 1518 may perform at least one of signal coding/processing, data processing, power control, input/output processing, and/or any other functionality that may enable the wireless device 1502 and the base station 1504 to operate in a wireless environment.

[0214] The processing system 1508 and/or the processing system 1518 may be connected to one or more peripherals 1516 and one or more peripherals 1526, respectively. The one or more peripherals 1516 and the one or more peripherals 1526 may include software and/or hardware that provide features and/or functionalities, for example, a speaker, a microphone, a keypad, a display, a touchpad, a power source, a satellite transceiver, a universal serial bus (USB) port, a hands-free headset, a frequency modulated (FM) radio unit, a media player, an

Internet browser, an electronic control unit (e.g., for a motor vehicle), and/or one or more sensors (e.g., an accelerometer, a gyroscope, a temperature sensor, a radar sensor, a lidar sensor, an ultrasonic sensor, a light sensor, a camera, and/or the like). The processing system 1508 and/or the processing system 1518 may receive user input data from and/or provide user output data to the one or more peripherals 1516 and/or the one or more peripherals 1526. The processing system 1518 in the wireless device 1502 may receive power from a power source and/or may be configured to distribute the power to the other components in the wireless device 1502. The power source may comprise one or more sources of power, for example, a battery, a solar cell, a fuel cell, or any combination thereof. The processing system 1508 and/or the processing system 1518 may be connected to a GPS chipset 1517 and a GPS chipset 1527, respectively. The GPS chipset 1517 and the GPS chipset 1527 may be configured to provide geographic location information of the wireless device 1502 and the base station 1504, respectively.

[0215] FIG. 16A illustrates an example structure for uplink transmission. A baseband signal representing a physical uplink shared channel may perform one or more functions. The one or more functions may comprise at least one of: scrambling; modulation of scrambled bits to generate complex-valued symbols; mapping of the complex-valued modulation symbols onto one or several transmission layers; transform precoding to generate complex-valued symbols; precoding of the complex-valued symbols; mapping of precoded complex-valued symbols to resource elements; generation of complex-valued time-domain Single Carrier-Frequency Division Multiple Access (SC-FDMA) or CP-OFDM signal for an antenna port; and/or the like. In an example, when transform precoding is enabled, a SC-FDMA signal for uplink transmission may be generated. In an example, when transform precoding is not enabled, an CP-OFDM signal for uplink transmission may be generated by FIG. 16A. These functions are illustrated as examples and it is anticipated that other mechanisms may be implemented in various embodiments.

[0216] FIG. 16B illustrates an example structure for modulation and up-conversion of a baseband signal to a carrier frequency. The baseband signal may be a complex-valued SC-FDMA or CP-OFDM baseband signal for an antenna port and/or a complex-valued Physical Random Access Channel (PRACH) baseband signal. Filtering may be employed prior to transmission.

[0217] FIG. 16C illustrates an example structure for downlink transmissions. A baseband signal representing a physical downlink channel may perform one or more functions. The one or more functions may comprise: scrambling of coded bits in a codeword to be transmitted on a physical channel; modulation of scrambled bits to generate complex-valued

modulation symbols; mapping of the complex-valued modulation symbols onto one or several transmission layers; precoding of the complex-valued modulation symbols on a layer for transmission on the antenna ports; mapping of complex-valued modulation symbols for an antenna port to resource elements; generation of complex-valued time-domain OFDM signal for an antenna port; and/or the like. These functions are illustrated as examples and it is anticipated that other mechanisms may be implemented in various embodiments.

[0218] FIG. 16D illustrates another example structure for modulation and up-conversion of a baseband signal to a carrier frequency. The baseband signal may be a complex-valued OFDM baseband signal for an antenna port. Filtering may be employed prior to transmission.

[0219] A wireless device may receive from a base station one or more messages (e.g. RRC messages) comprising configuration parameters of a plurality of cells (e.g. primary cell, secondary cell). The wireless device may communicate with at least one base station (e.g. two or more base stations in dual-connectivity) via the plurality of cells. The one or more messages (e.g. as a part of the configuration parameters) may comprise parameters of physical, MAC, RLC, PCDP, SDAP, RRC layers for configuring the wireless device. For example, the configuration parameters may comprise parameters for configuring physical and MAC layer channels, bearers, etc. For example, the configuration parameters may comprise parameters indicating values of timers for physical, MAC, RLC, PCDP, SDAP, RRC layers, and/or communication channels.

[0220] A timer may begin running once it is started and continue running until it is stopped or until it expires. A timer may be started if it is not running or restarted if it is running. A timer may be associated with a value (e.g. the timer may be started or restarted from a value or may be started from zero and expire once it reaches the value). The duration of a timer may not be updated until the timer is stopped or expires (e.g., due to BWP switching). A timer may be used to measure a time period/window for a process. When the specification refers to an implementation and procedure related to one or more timers, it will be understood that there are multiple ways to implement the one or more timers. For example, it will be understood that one or more of the multiple ways to implement a timer may be used to measure a time period/window for the procedure. For example, a random access response window timer may be used for measuring a window of time for receiving a random access response. In an example, instead of starting and expiry of a random access response window timer, the time difference between two time stamps may be used. When a timer is restarted, a process for measurement of time window may be restarted. Other example implementations may be provided to restart a measurement of a time window.

[0221] A device-to-device (D2D) communication may comprise two radio interfaces (e.g., a Uu interface and a PC5 interface). The Uu interface may be a radio interface between a wireless device and a radio access network. A base station may communicate with a wireless device via a Uu link with the Uu interface. The PC5 interface may be a radio interface between a first wireless device and a second wireless device. The first wireless device may communicate with the second wireless device via a sidelink (SL) with the PC5 interface.

[0222] FIG. 17A and FIG. 17B illustrate examples of an in-coverage D2D communication as per an aspect of an embodiment of the present disclosure. In the example of FIG. 17A, a first wireless device 1720 may communicate with a second wireless device 1730 via a sidelink. Both the first wireless device 1720 and the second wireless device 1730 may be within a coverage of a base station 1710. In an example, the base station 1710 may communicate with the first wireless device 1720 via a first Uu link. The base station 1710 may communicate with the second wireless device 1730 via a second Uu link.

[0223] In the example of FIG. 17B, a sidelink may connect a first wireless device 1760 with a second wireless device 1770. The first wireless device 1760 may be within a first coverage of a first base station 1740. The second wireless device 1770 may be within a second coverage of a second base station 1750. In an example, the first base station 1740 may communicate with the first wireless device 1760 via a first Uu link. The second base station 1750 may communicate with the second wireless device 1770 via a second Uu link.

[0224] FIG. 18 illustrates an example of a partial-coverage D2D communication as per an aspect of an embodiment of the present disclosure. A first wireless device 1820 may be within a coverage of a base station 1810. A second wireless device 1830 may be out of the coverage of the base station 1810. The first wireless device 1820 may communicate with the second wireless device 1830 via a sidelink. In the example of FIG. 18, the base station 1810 may be able to communicate with the first wireless device 1820 via a first Uu link. The base station 1810 may not be able to communicate with the second wireless device 1830 via a second Uu link.

[0225] FIG. 19 illustrates an example of an out-of-coverage D2D communication as per an aspect of an embodiment of the present disclosure. A first wireless device 1920 may communicate with a second wireless device 1930 via a sidelink. Both the first wireless device 1920 and the second wireless device 1930 may be out of a coverage of a base station 1910. The base station 1910 may not be able to communicate with the first wireless device 1920 via a first Uu link. The base station 1910 may not be able to communicate with the second wireless device 1930 via a second Uu link.

[0226] FIG. 20 illustrates an example of a D2D communication as per an aspect of an embodiment of the present disclosure. A transmitter (Tx) wireless device 2020 may transmit a first sidelink transmission to a first receiver (Rx) wireless device 2030. The Tx wireless device 2020 may transmit a second sidelink transmission to a second Rx wireless device 2040. In an example, the Tx wireless device 2020 may transmit the first sidelink transmission and the second sidelink transmission in a multicast manner. In an example, the Tx wireless device 2020 may transmit the first sidelink transmission and the second sidelink transmission in a unicast manner. The Tx wireless device 2020 may receive a first sidelink feedback from the first Rx wireless device 2030 in response to the first sidelink transmission. The Tx wireless device 2020 may receive a second sidelink feedback from the second Rx wireless device 2040 in response to the second sidelink transmission. In an example, the Tx wireless device 2020 may be able to communication with a base station 2010 when the Tx wireless device 2020 is in-coverage of the base station 2010. The Tx wireless device 2020 may send an uplink request 2060 to the base station 2010 for requesting radio resources for one or more sidelink transmissions before transmitting the one or more sidelink transmissions. The Tx wireless device 2020 may send an uplink report 2060 to the base station 2010 indicating information of the one or more sidelink transmissions. The Tx wireless device 2020 may receive control information from the base station 2010 for controlling the one or more sidelink communications. In an example, the Tx wireless device 2020 may not be able to communicate with the base station 2010 (e.g., for the uplink request, the uplink report, and the downlink control) when the Tx wireless device 2020 is out-of-coverage of the base station 2010.

[0227] FIG. 21 illustrates an example mapping between a resource pool (RP) and a zone as per an aspect of an embodiment of the present disclosure. In an example, a base station may transmit to a wireless device one or more messages comprising one or more configuration parameters. The one or more configuration parameters may indicate one or more sidelink bandwidth parts (BWPs) on a carrier in a cell. The one or more configuration parameters may comprise one or more RP configuration parameters indicating one or more RPs within a sidelink BWP of the one or more sidelink BWPs. An RP of the one or more RPs may be a set of time and frequency resources. In an example, the RP may comprise contiguous resources in the time and/or frequency domain on a carrier in a cell. In an example, the RP may comprise non-contiguous resources in the time and/or frequency domain on the carrier in the cell. In an example, the one or more configuration parameters may comprise one or more zone configuration parameters indicating a zone configuration. In an example, the zone configuration parameters may comprise a length parameter of a zone and a width parameter

of the zone. In an example, the zone configuration may further comprise a height parameter of the zone. The zone configuration may determine a geographic area referred to as a zone. The wireless device may use zone configuration parameters to determine a zone, in which the wireless device is geographically positioned, based on the wireless device's geographic location. The wireless device may use a zone identification (ID) to identify the zone. In an example, an RP may map to one or more zones based on one or more RP configuration parameters, configuring the RP, comprising the zone IDs of the one or more zones.

[0228] FIG. 22 illustrates an example of vehicle-to-everything (V2X) communications via a Uu interface and/or a PC5 interface as per an aspect of an embodiment of the present disclosure. In an example, the V2X communications may be vehicle-to-vehicle (V2V) communications. A wireless device in the V2V communications may be a vehicle. In an example, the V2X communications may be vehicle-to-pedestrian (V2P) communications. A wireless device in the V2P communications may be a pedestrian equipped with a wireless device. In an example, the V2X communications may be vehicle-to-infrastructure (V2I) communications. The infrastructure in the V2I communications may be a base station or a road side unit. A wireless device in the V2X communications may be a Tx wireless device performing sidelink transmissions to a Rx wireless device. The wireless device in the V2X communications may be the Rx wireless device receiving sidelink transmissions from the Tx wireless device.

[0229] In existing technologies, uplink preemption may be supported for low-latency high-reliability communication. In an example, a base station may assign first radio resources to a first wireless device for a first transmission. The first transmission may be a first uplink transmission. Before the first transmission, the base station may assign second radio resources to a second wireless device for a second transmission associated with latency-critical data. The second transmission may be a second uplink transmission. In the case of a high-load data traffic over the radio resources, the base station may preempt the first transmission using the first radio resources (by the first wireless device) so that at least a portion of the first radio resources can be used by the second wireless device to complete the latency-critical second transmission. Accordingly, the base station may transmit a first downlink control information (DCI) to the first wireless device for canceling first radio resources assigned for the first transmission. The first DCI may be a group common DCI that is decodable by a group of one or more wireless devices (including, for example, the first wireless device). The base station may transmit a second DCI to the second wireless device for assigning the first radio resources for the latency-critical second transmission. The second

transmission from the second wireless device may preempt the first transmission from the first wireless device.

[0230] In an example, implementing uplink preemption for a sidelink communication may decrease radio resource efficiency. FIG. 23 illustrates an example of a sidelink preemption following uplink preemption. A communication range 2345 may be a communication range of a first sidelink transmission from a wireless device 2310. A communication range 2350 may be a communication range of a second sidelink transmission from a wireless device 2315. For preempting the second sidelink transmission by the first sidelink transmission, a base station 2305 may transmit a first group common DCI, to wireless devices (e.g., 2310, 2315, 2320, 2325, 2330, 2335, 2340 in FIG. 23) within a group, for canceling first radio resources assigned for the second sidelink transmission by the wireless device 2315. A group range 2355 may define a coverage of the group. The wireless devices (e.g., 2310, 2315, 2320, 2325, 2330, 2335, 2340 in FIG. 23) within the group may not be able to transmit a sidelink transmission via the first radio resources based on the first group common DCI. Preemption using the first group common DCI may decrease radio resource efficiency when the wireless device 2310 is a certain distance from the wireless device 2315 (as shown in FIG. 23, where the communication range 2345 does not overlap with the communication range 2350). This is because the wireless device 2315 may be able to transmit the second sidelink transmission via the first radio resources without increasing interference to the first sidelink transmission. There is a need to develop an enhanced method for sidelink preemption to solve the problem of decreasing radio resource efficiency by implementing uplink preemption to sidelink preemption.

[0231] Example embodiments implements an enhanced method for sidelink preemption. In an example embodiment, a base station may transmit a group common DCI for canceling assigned radio resources to one or more wireless devices. The group common DCI may further assign the cancelled radio resources to a second Tx wireless device. In an example embodiment, a base station may transmit multiple DCIs for canceling assigned radio resources to one or more wireless devices, wherein the multiple DCIs are not group common DCIs. In an example embodiment, a base station may transmit one or more DCIs for indicating sidelink preemption to one or more wireless devices. The one or more DCIs may assign first radio resources to a wireless device for a standalone sidelink control information (SA SCI) transmission. The one or more DCIs may assign second radio resources to the wireless device for a sidelink transmission. The one or more DCIs may comprise group common DCI. The one or more DCIs may comprise specific DCI to the wireless device. In an example embodiment, a first Tx wireless device may receive a DCI assigning a first radio

resources from a base station. The base station may transmit one or more group common DCIs indicating cancelation of the first radio resources. The first Tx wireless device, in response to receiving the one or more group common DCIs for canceling assigned radio resources, may determine whether to cancel the first radio resources based on the one or more group common DCIs and one or more sidelink control information (SCIs) indicating a sidelink preemption. For example, a second Tx wireless device may transmit the one or more SCIs indicating a sidelink preemption (e.g., a resource reservation, an indication of resource stealing, a resource assignment, and/or the like) on the first radio resources. In response to receiving the one or more SCIs, the first Tx wireless device may determine to cancel the first radio resources, when a distance between the first Tx wireless device and second Tx wireless device being smaller than a summation of a first distance threshold and a second distance threshold. In response to receiving the one or more SCIs, the first Tx wireless device may not cancel the first radio resources but reduce a transmission power via the first radio resources, when the distance between the first Tx wireless device and second Tx wireless device being smaller than the summation of the first distance threshold and the second distance threshold. In response to receiving the one or more SCIs, the first Tx wireless device may not cancel the first radio resources, when the distance between the first Tx wireless device and second Tx wireless device being larger than or equal to the summation of the first distance threshold and the second distance threshold.

[0232] Example embodiments of the present disclosure may reduce the number of DCI transmissions for implementing a sidelink preemption. For example, a sidelink preemption (e.g., resource stealing/resource reservation adaptation) may be accomplished based on a group common DCI instead of separate multiple unicast DCIs. Example embodiments of the present disclosure may increase radio resource efficiency during a sidelink preemption. For example, a sidelink operation may be confirmed based on reception of one or more SCIs to minimize unnecessary resource cancelation. Example embodiments of the present disclosure may reduce interference among multiple sidelink transmission during sidelink preemption. For example, a first communication range of a first sidelink from a first wireless device may be overlapped with a second communication range of a second sidelink from a second wireless device. The first wireless device may reduce a transmission power to minimize potential interference to a third wireless device which is in an overlapped area of the first communication range and the second communication range.

[0233] For sidelink communications, a sidelink preemption may be based on sidelink priorities. A sidelink priority may be determined based on quality of service (QoS) requirements of the sidelink transmission such as a latency requirement of the sidelink

transmission and reliability requirement of the transmission, etc. The sidelink priority may be a data packet priority such as ProSe Per-Packet Priority (PPPP). The sidelink priority may be related to logical channel prioritization (LCP). A first sidelink transmission may preempt a second sidelink transmission when resources of transmissions are partially or fully overlapped, in response to a first priority of the first sidelink transmission being higher than a second priority of the second sidelink transmission.

[0234] FIG. 24 illustrates an example of a sidelink preemption as per an aspect of an embodiment of the present disclosure. In an example, a base station 2405 may transmit a DCI 2425 to a wireless device 2410. The DCI 2425 may indicate a sidelink preemption. The DCI 2425 may indicate first radio resources for a SCI transmission 2440. The SCI 2440 may be a standalone (SA) SCI. A SA SCI may be a SCI transmitted within a time slot without a transport block (TB) attached with the SA SCI in the same time slot. In an example, the first radio resources may be within a first RP, wherein the first RP is configured for sidelink communications. In an example, the first radio resources may comprise radio resources configured for uplink and/or downlink transmissions. The DCI 2425 may indicate second radio resources for a first sidelink transmission. In an example, the second radio resources may be within a second RP, wherein the second RP is configured for sidelink communications. In an example, the second radio resources may comprise radio resources configured for uplink and/or downlink transmissions. The first RP may be different from the second RP. The DCI 2425 may indicate an identification (ID) of a wireless device. The DCI 2425 may be a group common DCI. The wireless device 2410 may determine the ID of the wireless device in the DCI 2425 being the same as a first ID of the wireless device 2410. In response to receiving the DCI 2425, the wireless device 2410 may transmit the SCI 2440 via the first radio resources. The SCI 2440 may indicate a sidelink preemption. The SCI 2440 may indicate the second radio resources for the first sidelink transmission. The SCI 2440 may indicate a first geographic location of the wireless device 2410. The SCI 2440 may indicate a first distance threshold of the first sidelink transmission.

[0235] A base station 2420 may transmit a DCI 2430 to a wireless device 2415. The DCI 2430 may indicate the sidelink preemption. The DCI 2430 may indicate the first radio resources for the SCI transmission 2440. The DCI 2430 may indicate the second radio resources for the first sidelink transmission. The DCI 2430 may indicate the ID of the wireless device. The base station 2405 may be the same as the base station 2420. The DCI 2430 may be a group common DCI. The DCI 2425 may be the same as the DCI 2430, when the DCI 2425 and the DCI 2430 are group common DCIs. The wireless device 2415 may determine the ID of the wireless device in the DCI 2430 being different from a second ID of

the wireless device 2415. In response to receiving the DCI 2430, the wireless device 2415 may determine a conflict of radio resources between third radio resources and at least one of the first radio resources and the second radio resources. In an example, a base station may assign the third radio resources, to the wireless device 2415, for a second sidelink transmission. The base station may be the base station 2420. In an example, the wireless device 2415 may determine the third radio resources for the second sidelink transmission. The wireless device 2415 may receive the SCI 2440 via the first radio resources after determining the conflict of radio resources. The wireless device 2415 may determine to transmit a request for fourth radio resources, to the base station 2420, for the second sidelink transmission in response to receiving the SCI 2440.

[0236] FIG. 25 illustrates an example of a sidelink preemption as per an aspect of an embodiment of the present disclosure. In an example, a base station 2405 may transmit a DCI 2510 to a wireless device 2410. The DCI 2510 may indicate a sidelink preemption. The DCI 2510 may indicate first radio resources for a SCI transmission 2550. The SCI 2550 may be a SA SCI. In an example, the first radio resources may be within a first RP, wherein the first RP is configured for sidelink communications. In an example, the first radio resources may comprise radio resources configured for uplink and/or downlink transmissions. The DCI 2510 may indicate second radio resources for a first sidelink transmission. In an example, the second radio resources may be within a second RP, wherein the second RP is configured for sidelink communications. In an example, the second radio resources may comprise radio resources configured for uplink and/or downlink transmissions. The first RP may be different from the second RP. The DCI 2510 may be a group common DCI. The base station 2405 may transmit one or more DCIs 2540 to the wireless device 2410. The one or more DCIs 2540 may indicate the sidelink preemption. The one or more DCIs 2540 may indicate an ID of a wireless device. The one or more DCIs 2540 may indicate the first radio resources for the SCI transmission 2550. The one or more DCIs 2540 may indicate the second radio resources for the first sidelink transmission. The one or more DCIs 2540 may be specific (e.g., UE-specific) DCIs to the wireless device 2410. The wireless device 2410 may determine the ID of the wireless device in the one or more DCIs 2540 being the same as a first ID of the wireless device 2410. In response to receiving the one or more DCIs 2540, the wireless device 2410 may transmit the SCI 2550 via the first radio resources. The SCI 2550 may indicate the sidelink preemption. The SCI 2550 may indicate the second radio resources for the first sidelink transmission. The SCI 2550 may indicate a first geographic location of the wireless device 2410. The SCI 2550 may indicate a first distance threshold of the first sidelink transmission.

[0237] A base station 2420 may transmit a DCI 2520 to a wireless device 2415. The DCI 2520 may indicate the sidelink preemption. The DCI 2520 may indicate the first radio resources for the SCI transmission 2550. The DCI 2520 may indicate the second radio resources for the first sidelink transmission. The base station 2405 may be the same as the base station 2420. The DCI 2520 may be a group common DCI. The DCI 2510 may be the same as the DCI 2520, when the DCI 2510 and the DCI 2520 are group common DCIs. In response to receiving the DCI 2520, the wireless device 2415 may determine a conflict of radio resources between third radio resources and at least one of the first radio resources and the second radio resources. In an example, a base station may assign the third radio resources, to the wireless device 2415, for a second sidelink transmission. The base station may be the base station 2420. In an example, the wireless device 2415 may determine the third radio resources for the second sidelink transmission. The wireless device 2415 may receive the SCI 2550 via the first radio resources after determining the conflict of radio resources. The wireless device 2415 may determine to transmit a request for fourth radio resources, to the base station 2420, for the second sidelink transmission in response to receiving the SCI 2550.

[0238] FIG. 26 illustrates an example of a sidelink preemption as per an aspect of an embodiment of the present disclosure. In an example, a base station 2405 may transmit a DCI 2610 to a wireless device 2410. The DCI 2610 may indicate a sidelink preemption. The DCI 2610 may indicate first radio resources for a SCI transmission 2640. The SCI 2640 may be a SA SCI. In an example, the first radio resources may be within a first RP, wherein the first RP is configured for sidelink communications. In an example, the first radio resources may comprise radio resources configured for uplink and/or downlink transmissions. The DCI 2610 may indicate second radio resources for a first sidelink transmission. In an example, the second radio resources may be within a second RP, wherein the second RP is configured for sidelink communications. In an example, the second radio resources may comprise radio resources configured for uplink and/or downlink transmissions. The first RP may be different from the second RP. The DCI 2610 may indicate an ID of a wireless device. The DCI 2610 may be a group common DCI. The wireless device 2410 may determine the ID of the wireless device in the DCI 2610 being the same as a first ID of the wireless device 2410. In response to receiving the DCI 2610, the wireless device 2410 may transmit the SCI 2640 via the first radio resources. The SCI 2640 may indicate a sidelink preemption. The SCI 2640 may indicate the second radio resources for the first sidelink transmission. The SCI 2640 may indicate a first geographic location of the wireless device 2410. The SCI 2640 may indicate a first distance threshold of the first sidelink transmission.

[0239] A base station 2420 may transmit a DCI 2620 to a wireless device 2415. The DCI 2620 may indicate the sidelink preemption. The DCI 2620 may indicate the first radio resources for the SCI transmission 2640. The DCI 2620 may indicate the second radio resources for the first sidelink transmission. The DCI 2620 may indicate the ID of the wireless device. The base station 2405 may be the same as the base station 2420. The DCI 2620 may be a group common DCI. The DCI 2610 may be the same as the DCI 2620, when the DCI 2610 and the DCI 2620 are group common DCIs. The wireless device 2415 may determine the ID of the wireless device in the DCI 2620 being different from a second ID of the wireless device 2415. In response to receiving the DCI 2620, the wireless device 2415 may determine a conflict of radio resources between third radio resources and at least one of the first radio resources and the second radio resources. In an example, a base station may assign the third radio resources, to the wireless device 2415, for a second sidelink transmission. The base station may be the base station 2420. In an example, the wireless device 2415 may determine the third radio resources for the second sidelink transmission. The wireless device 2415 may receive the SCI 2640 via the first radio resources after determining the conflict of radio resources. The Tx wireless device 2415 may determine to reduce a transmission power and transmit the second sidelink transmission via the third radio resources, in response to receiving the SCI 2640.

[0240] FIG. 27 illustrates an example of a sidelink preemption as per an aspect of an embodiment of the present disclosure. In an example, a base station 2405 may transmit a DCI 2710 to a wireless device 2410. The DCI 2710 may indicate a sidelink preemption. The DCI 2710 may indicate first radio resources for a SCI transmission 2750. The SCI 2750 may be a SA SCI. In an example, the first radio resources may be within a first RP, wherein the first RP is configured for sidelink communications. In an example, the first radio resources may comprise radio resources configured for uplink and/or downlink transmissions. The DCI 2710 may indicate second radio resources for a first sidelink transmission. In an example, the second radio resources may be within a second RP, wherein the second RP is configured for sidelink communications. In an example, the second radio resources may comprise radio resources configured for uplink and/or downlink transmissions. The first RP may be different from the second RP. The DCI 2710 may be a group common DCI. The base station 2405 may transmit one or more DCIs 2740 to the wireless device 2410. The one or more DCIs 2740 may indicate the sidelink preemption. The one or more DCIs 2740 may indicate an ID of a wireless device. The one or more DCIs 2740 may indicate the first radio resources for the SCI transmission 2750. The one or more DCIs 2740 may indicate the second radio resources for the first sidelink transmission. The one or more DCIs 2740 may be specific

(e.g., UE-specific) DCIs to the wireless device 2410. The wireless device 2410 may determine the ID of the wireless device in the one or more DCIs 2740 being the same as a first ID of the wireless device 2410. In response to receiving the one or more DCIs 2740, the wireless device 2410 may transmit the SCI 2750 via the first radio resources. The SCI 2750 may indicate the sidelink preemption. The SCI 2750 may indicate the second radio resources for the first sidelink transmission. The SCI 2750 may indicate a first geographic location of the wireless device 2410. The SCI 2750 may indicate a first distance threshold of the first sidelink transmission.

[0241] A base station 2420 may transmit a DCI 2720 to a wireless device 2415. The DCI 2720 may indicate the sidelink preemption. The DCI 2720 may indicate the first radio resources for the SCI transmission 2750. The DCI 2720 may indicate the second radio resources for the first sidelink transmission. The base station 2405 may be the same as the base station 2420. The DCI 2720 may be a group common DCI. The DCI 2710 may be the same as the DCI 2720, when the DCI 2710 and the DCI 2720 are group common DCIs. In response to receiving the DCI 2720, the wireless device 2415 may determine a conflict of radio resources between third radio resources and at least one of the first radio resources and the second radio resources. In an example, a base station may assign the third radio resources, to the wireless device 2415, for a second sidelink transmission. The base station may be the base station 2420. In an example, the wireless device 2415 may determine the third radio resources for the second sidelink transmission. The wireless device 2415 may receive the SCI 2750 via the first radio resources after determining the conflict of radio resources. The wireless device 2415 may determine to reduce a transmission power and transmit the sidelink transmission via the third radio resources, in response to receiving the SCI 2750.

[0242] FIG. 28 illustrates an example of a sidelink preemption as per an aspect of an embodiment of the present disclosure. In an example, a base station 2405 may transmit a DCI 2810 to a wireless device 2410. The DCI 2810 may indicate a sidelink preemption. The DCI 2810 may indicate second radio resources for a first sidelink transmission. In an example, the second radio resources may be within a second RP, wherein the second RP is configured for sidelink communications. In an example, the second radio resources may comprise radio resources configured for uplink and/or downlink transmissions. The DCI 2810 may indicate an ID of a wireless device. The DCI 2810 may be a group common DCI. The wireless device 2410 may determine the ID of the wireless device in the DCI 2810 being the same as a first ID of the wireless device 2410. In response to receiving the DCI 2810, the wireless device 2410 may determine first radio resources for a SCI transmission 2850. The SCI 2850 may be

a SA SCI. In an example, the first radio resources may be within a first RP, wherein the first RP is configured for sidelink communications. In an example, the first radio resources may comprise radio resources configured for uplink and/or downlink transmissions. The first RP may be different from the second RP. The wireless device 2410 may transmit the SCI 2850 via the first radio resources. The SCI 2850 may indicate the sidelink preemption. The SCI 2850 may indicate the second radio resources for the first sidelink transmission. The SCI 2850 may indicate a first geographic location of the wireless device 2410. The SCI 2850 may indicate a first distance threshold of the first sidelink transmission.

[0243] A base station 2420 may transmit a DCI 2820 to a wireless device 2415. The DCI 2820 may indicate the sidelink preemption. The DCI 2820 may indicate the second radio resources for the sidelink transmission 2850. The DCI 2820 may indicate the ID of the wireless device. The base station 2405 may be the same as the base station 2420. The DCI 2820 may be a group common DCI. The DCI 2810 may be the same as the DCI 2820, when the DCI 2810 and the DCI 2820 are group common DCIs. The wireless device 2415 may determine the ID of the wireless device in the DCI 2820 being different from a second ID of the wireless device 2415. In response to receiving the DCI 2820, the wireless device 2415 may determine a conflict of radio resources between third radio resources and the second radio resources. In an example, a base station may assign the third radio resources, to the wireless device 2415, for a second sidelink transmission. The base station may be the base station 2420. In an example, the wireless device 2415 may determine the third radio resources for the second sidelink transmission. The wireless device 2415 may start a time window 2870 in response to determining the conflict of radio resources. In an example, a base station may transmit an RRC message, to the wireless device 2415, for configuring the time window 2870. The base station may be the base station 2420. The RRC message may be a MAC CE. The RRC message may be a DCI. In an example, the time window 2870 may be stored in a Subscriber Identity Module (SIM) card of the wireless device 2415. The wireless device 2415 may receive the SCI 2850 via the first radio resources until an expiry of the time window 2870. The wireless device 2415 may determine to transmit a request for fourth radio resources, to the base station 2420, for the second sidelink transmission in response to receiving the SCI 2850 within the time window 2870. In an example, the wireless device 2415 may not receive the SCI 2850 via the first radio resources until the expiry of the time window 2870. The wireless device 2415 may transmit the second sidelink transmission via the third radio resources, in response to not receiving the SCI 2850 via the first radio resources until the expiry of the time window 2870.

[0244] FIG. 29 illustrates an example of a sidelink preemption as per an aspect of an embodiment of the present disclosure. In an example, a base station 2405 may transmit a DCI 2910 to a wireless device 2410. The DCI 2910 may indicate a sidelink preemption. The DCI 2910 may indicate second radio resources for a first sidelink transmission. In an example, the second radio resources may be within a second RP, wherein the second RP is configured for sidelink communications. In an example, the second radio resources may comprise radio resources configured for uplink and/or downlink transmissions. The DCI 2910 may be a group common DCI. The base station 2405 may transmit one or more DCIs 2940 to the wireless device 2410. The one or more DCIs 2940 may indicate an ID of a wireless device. The one or more DCIs 2940 may indicate the second radio resources for the first sidelink transmission. The one or more DCIs 2940 may be specific (e.g., UE-specific) DCIs to the wireless device 2410. The wireless device 2410 may determine the ID of the wireless device in the one or more DCIs 2940 being the same as a first ID of the wireless device 2410. In response to receiving the one or more DCIs 2940, the wireless device 2410 may determine first radio resources for a SCI transmission. In an example, the first radio resources may be within a first RP, wherein the first RP is configured for sidelink communications. In an example, the first radio resources may comprise radio resources configured for uplink and/or downlink transmissions. The first RP may be different from the second RP. The wireless device 2410 may transmit the SCI 2960 via the first radio resources. The SCI 2960 may indicate the sidelink preemption. The SCI 2960 may indicate the second radio resources for the first sidelink transmission. The SCI 2960 may indicate a first geographic location of the wireless device 2410. The SCI 2960 may indicate a first distance threshold of the first sidelink transmission.

[0245] A base station 2420 may transmit a DCI 2920 to a wireless device 2415. The DCI 2920 may indicate the sidelink preemption. The DCI 2920 may indicate the second radio resources for the first sidelink transmission. The DCI 2920 may indicate the ID of the wireless device. The base station 2405 may be the same as the base station 2420. The DCI 2920 may be a group common DCI. The DCI 2910 may be the same as the DCI 2920, when the DCI 2910 and the DCI 2920 are group common DCIs. In response to receiving the DCI 2920, the wireless device 2415 may determine a conflict of radio resources between third radio resources and the second radio resources. In an example, a base station may assign the third radio resources, to the wireless device 2415, for a second sidelink transmission. The base station may be the base station 2420. In an example, the wireless device 2415 may determine the third radio resources for the second sidelink transmission. The wireless device 2415 may start a time window 2980 in response to determining the conflict of radio

resources. In an example, a base station may transmit an RRC message, to the wireless device 2415, for configuring the time window 2980. The base station may be the base station 2420. The RRC message may be a MAC CE. The RRC message may be a DCI. In an example, the time window 2980 may be stored in a SIM card of the wireless device 2415. The wireless device 2415 may receive the SCI 2960 via the first radio resources until an expiry of the time window 2980. The wireless device 2415 may determine to transmit a request for fourth radio resources, to the base station 2420, for the second sidelink transmission in response to receiving the SCI 2960 within the time window 2980. In an example, the wireless device 2415 may not receive the SCI 2960 via the first radio resources until the expiry of the time window 2980. The wireless device 2415 may transmit the second sidelink transmission via the third radio resources, in response to not receiving the SCI 2960 via the first radio resources until the expiry of the time window 2980.

[0246] FIG. 30 illustrates an example of a sidelink preemption as per an aspect of an embodiment of the present disclosure. In an example, a base station 2405 may transmit a DCI 3010 to a wireless device 2410. The DCI 3010 may indicate a sidelink preemption. The DCI 3010 may indicate second radio resources for a first sidelink transmission. In an example, the second radio resources may be within a second RP, wherein the second RP is configured for sidelink communications. In an example, the second radio resources may comprise radio resources configured for uplink and/or downlink transmissions. The DCI 3010 may indicate an ID of a wireless device. The DCI 3010 may be a group common DCI. The wireless device 2410 may determine the ID of the wireless device in the DCI 3010 being the same as a first ID of the wireless device 2410. In response to receiving the DCI 3010, the wireless device 2410 may determine first radio resources for a SCI transmission 3050. The SCI 3050 may be a SA SCI. In an example, the first radio resources may be within a first RP, wherein the first RP is configured for sidelink communications. In an example, the first radio resources may comprise radio resources configured for uplink and/or downlink transmissions. The first RP may be different from the second RP. The wireless device 2410 may transmit the SCI 3050 via the first radio resources. The SCI 3050 may indicate the sidelink preemption. The SCI 3050 may indicate the second radio resources for the first sidelink transmission. The SCI 3050 may indicate a first geographic location of the wireless device 2410. The SCI 3050 may indicate a first distance threshold of the first sidelink transmission.

[0247] A base station 2420 may transmit a DCI 3020 to a wireless device 2415. The DCI 3020 may indicate the sidelink preemption. The DCI 3020 may indicate the second radio resources for the sidelink transmission 3050. The DCI 3020 may indicate the ID of the wireless device. The base station 2405 may be the same as the base station 2420. The DCI

3020 may be a group common DCI. The DCI 3010 may be the same as the DCI 3020, when the DCI 3010 and the DCI 3020 are group common DCIs. The wireless device 2415 may determine the ID of the wireless device in the DCI 3020 being different from a second ID of the wireless device 2415. In response to receiving the DCI 3020, the wireless device 2415 may determine a conflict of radio resources between third radio resources and the second radio resources. In an example, a base station may assign the third radio resources, to the wireless device 2415, for a second sidelink transmission. The base station may be the base station 2420. In an example, the wireless device 2415 may determine the third radio resources for the second sidelink transmission. The wireless device 2415 may start a time window 3070 in response to determining the conflict of radio resources. In an example, a base station may transmit an RRC message, to the wireless device 2415, for configuring the time window 3070. The base station may be the base station 2420. The RRC message may be a MAC CE. The RRC message may be a DCI. In an example, the time window 3070 may be stored in a SIM card of the wireless device 2415. The wireless device 2415 may receive the SCI 3050 via the first radio resources until an expiry of the time window 3070. The Tx wireless device 2415 may determine to reduce a transmission power and transmit the second sidelink transmission via the third radio resources, in response to receiving the SCI 3050 within the time window 3070. In an example, the wireless device 2415 may not receive the SCI 3050 via the first radio resources until the expiry of the time window 3070. The wireless device 2415 may transmit the second sidelink transmission via the third radio resources, in response to not receiving the SCI 3050 via the first radio resources until the expiry of the time window 3070.

[0248] FIG. 31 illustrates an example of a sidelink preemption as per an aspect of an embodiment of the present disclosure. In an example, a base station 2405 may transmit a DCI 3110 to a wireless device 2410. The DCI 3110 may indicate a sidelink preemption. The DCI 3110 may indicate second radio resources for a first sidelink transmission. In an example, the second radio resources may be within a second RP, wherein the second RP is configured for sidelink communications. In an example, the second radio resources may comprise radio resources configured for uplink and/or downlink transmissions. The DCI 3110 may be a group common DCI. The base station 2405 may transmit one or more DCIs 3140 to the wireless device 2410. The one or more DCIs 3140 may indicate an ID of a wireless device. The one or more DCIs 3140 may indicate the second radio resources for the first sidelink transmission. The one or more DCIs 3140 may be specific (e.g., UE-specific) DCIs to the wireless device 2410. The wireless device 2410 may determine the ID of the wireless device in the one or more DCIs 3140 being the same as a first ID of the wireless device 2410. In

response to receiving the one or more DCIs 3140, the wireless device 2410 may determine first radio resources for a SCI transmission. In an example, the first radio resources may be within a first RP, wherein the first RP is configured for sidelink communications. In an example, the first radio resources may comprise radio resources configured for uplink and/or downlink transmissions. The first RP may be different from the second RP. The wireless device 2410 may transmit the SCI 3160 via the first radio resources. The SCI 3160 may indicate the sidelink preemption. The SCI 3160 may indicate the second radio resources for the first sidelink transmission. The SCI 3160 may indicate a first geographic location of the wireless device 2410. The SCI 3160 may indicate a first distance threshold of the first sidelink transmission.

[0249] A base station 2420 may transmit a DCI 3120 to a wireless device 2415. The DCI 3120 may indicate the sidelink preemption. The DCI 3120 may indicate the second radio resources for the first sidelink transmission. The DCI 3120 may indicate the ID of the wireless device. The base station 2405 may be the same as the base station 2420. The DCI 3120 may be a group common DCI. The DCI 3110 may be the same as the DCI 3120, when the DCI 3110 and the DCI 3120 are group common DCIs. In response to receiving the DCI 3120, the wireless device 2415 may determine a conflict of radio resources between third radio resources and the second radio resources. In an example, a base station may assign the third radio resources, to the wireless device 2415, for a second sidelink transmission. The base station may be the base station 2420. In an example, the wireless device 2415 may determine the third radio resources for the second sidelink transmission. The wireless device 2415 may start a time window 3180 in response to determining the conflict of radio resources. In an example, a base station may transmit an RRC message, to the wireless device 2415, for configuring the time window 3180. The base station may be the base station 2420. The RRC message may be a MAC CE. The RRC message may be a DCI. In an example, the time window 3180 may be stored in a SIM card of the wireless device 2415. The wireless device 2415 may receive the SCI 3160 via the first radio resources until an expiry of the time window 3180. The Tx wireless device 2415 may determine to reduce a transmission power and transmit the second sidelink transmission via the third radio resources, in response to receiving the SCI 3160 within the time window 3180. In an example, the wireless device 2415 may not receive the SCI 3160 via the first radio resources until the expiry of the time window 3180. The wireless device 2415 may transmit the second sidelink transmission via the third radio resources, in response to not receiving the SCI 3160 via the first radio resources until the expiry of the time window 3180.

[0250] FIG. 32 illustrates an example of a sidelink preemption as per an aspect of an embodiment of the present disclosure. In an example, a base station 2405 may transmit a DCI 3210 to a wireless device 2410. The DCI 3210 may indicate a sidelink preemption. The DCI 3210 may indicate first radio resources for a SCI transmission 3220. The SCI 3220 may be a SA SCI. In an example, the first radio resources may be within a first RP, wherein the first RP is configured for sidelink communications. In an example, the first radio resources may comprise radio resources configured for uplink and/or downlink transmissions. The DCI 3210 may indicate second radio resources for a first sidelink transmission. In an example, the second radio resources may be within a second RP, wherein the second RP is configured for sidelink communications. In an example, the second radio resources may comprise radio resources configured for uplink and/or downlink transmissions. The first RP may be different from the second RP. The DCI 3210 may indicate an ID of a wireless device. The DCI 3210 may be a group common DCI. The wireless device 2410 may determine the ID of the wireless device in the DCI 3210 being the same as a first ID of the wireless device 2410. In response to receiving the DCI 3210, the wireless device 2410 may transmit the SCI 3220 via the first radio resources. The SCI 3220 may indicate the sidelink preemption. The SCI 3220 may indicate the second radio resources for the first sidelink transmission. The SCI 3220 may indicate a first geographic location of the wireless device 2410. The SCI 3220 may indicate a first distance threshold of the first sidelink transmission.

[0251] A wireless device 2415 may receive the SCI 3220 via the first radio resources. In response to receiving the SCI 3220, the wireless device 2415 may determine a conflict of radio resources between third radio resources and the second radio resources. In an example, a base station may assign the third radio resources, to the wireless device 2415, for a second sidelink transmission. The base station may be the base station 2405. In an example, the wireless device 2415 may determine the third radio resources for the second sidelink transmission. In an example, the wireless device 2415 may be in-coverage of a network. The wireless device 2415 may determine to transmit a request, to a base station, for requesting fourth radio resources for the second sidelink transmission in response to receiving the SCI 3220. In an example, the wireless device 2415 may be out-of-coverage of the network. The wireless device 2415 may determine to select fourth radio resources for the second sidelink transmission in response to receiving the SCI 3220.

[0252] FIG. 33 illustrates an example of a sidelink preemption as per an aspect of an embodiment of the present disclosure. In an example, a base station 2405 may transmit a DCI 3310 to a wireless device 2410. The DCI 3310 may indicate a sidelink preemption. The DCI 3310 may indicate first radio resources for a SCI transmission 3330. The SCI 3330 may be a

SA SCI. In an example, the first radio resources may be within a first RP, wherein the first RP is configured for sidelink communications. In an example, the first radio resources may comprise radio resources configured for uplink and/or downlink transmissions. The DCI 3310 may indicate second radio resources for a first sidelink transmission. In an example, the second radio resources may be within a second RP, wherein the second RP is configured for sidelink communications. In an example, the second radio resources may comprise radio resources configured for uplink and/or downlink transmissions. The first RP may be different from the second RP. The DCI 3310 may be a group common DCI. The base station 2405 may transmit one or more DCIs 3320 to the wireless device 2410, wherein the one or more DCIs 3320 may indicate an ID of a wireless device. The one or more DCIs 3320 may indicate the first radio resources for the SCI transmission 3330. The one or more DCIs 3320 may indicate the second radio resources for the first sidelink transmission. The one or more DCIs 3320 may be specific (e.g., UE-specific) DCIs to the wireless device 2410. The wireless device 2410 may determine the ID of the wireless device in the DCI 3320 being the same as a first ID of the wireless device 2410. In response to receiving the DCI 3320, the wireless device 2410 may transmit the SCI 3330 via the first radio resources. The SCI 3330 may indicate the sidelink preemption. The SCI 3330 may indicate the second radio resources for the first sidelink transmission. The SCI 3330 may indicate a first geographic location of the wireless device 2410. The SCI 3330 may indicate a first distance threshold of the first sidelink transmission.

[0253] A wireless device 2415 may receive the SCI 3330 via the first radio resources. In response to receiving the SCI 3330, the wireless device 2415 may determine a conflict of radio resources between third radio resources and the second radio resources. In an example, a base station may assign the third radio resources, to the wireless device 2415, for a second sidelink transmission. The base station may be the base station 2405. In an example, the wireless device 2415 may determine the third radio resources for the second sidelink transmission. In an example, the wireless device 2415 may be in-coverage of a network. The wireless device 2415 may determine to transmit a request, to a base station, for requesting fourth radio resources for the second sidelink transmission in response to receiving the SCI 3330. In an example, the wireless device 2415 may be out-of-coverage of the network. The wireless device 2415 may determine to select fourth radio resources for the second sidelink transmission in response to receiving the SCI 3330.

[0254] FIG. 34 illustrates an example of a sidelink preemption as per an aspect of an embodiment of the present disclosure. In an example, a base station 2405 may transmit a DCI 3410 to a wireless device 2410. The DCI 3410 may indicate a sidelink preemption. The DCI

3410 may indicate first radio resources for a SCI transmission 3420. The SCI 3420 may be a SA SCI. In an example, the first radio resources may be within a first RP, wherein the first RP is configured for sidelink communications. In an example, the first radio resources may comprise radio resources configured for uplink and/or downlink transmissions. The DCI 3410 may indicate second radio resources for a first sidelink transmission. In an example, the second radio resources may be within a second RP, wherein the second RP is configured for sidelink communications. In an example, the second radio resources may comprise radio resources configured for uplink and/or downlink transmissions. The first RP may be different from the second RP. The DCI 3410 may indicate an ID of a wireless device. The DCI 3410 may be a group common DCI. The wireless device 2410 may determine the ID of the wireless device in the DCI 3410 being the same as a first ID of the wireless device 2410. In response to receiving the DCI 3410, the wireless device 2410 may transmit the SCI 3420 via the first radio resources. The SCI 3420 may indicate the sidelink preemption. The SCI 3420 may indicate the second radio resources for the first sidelink transmission. The SCI 3420 may indicate a first geographic location of the wireless device 2410. The SCI 3420 may indicate a first distance threshold of the first sidelink transmission.

[0255] A wireless device 2415 may receive the SCI 3420 via the first radio resources. In response to receiving the SCI 3420, the wireless device 2415 may determine a conflict of radio resources between third radio resources and the second radio resources. In an example, a base station may assign the third radio resources, to the wireless device 2415, for a second sidelink transmission. The base station may be the base station 2405. In an example, the wireless device 2415 may determine the third radio resources for the second sidelink transmission. The Tx wireless device 2415 may determine to reduce a transmission power and transmit the sidelink transmission via the third radio resources, in response to receiving the SCI 3420.

[0256] FIG. 35 illustrates an example of a sidelink preemption as per an aspect of an embodiment of the present disclosure. In an example, a base station 2405 may transmit a DCI 3510 to a wireless device 2410. The DCI 3510 may indicate a sidelink preemption. The DCI 3510 may indicate first radio resources for a SCI transmission 3530. The SCI 3530 may be a SA SCI. In an example, the first radio resources may be within a first RP, wherein the first RP is configured for sidelink communications. In an example, the first radio resources may comprise radio resources configured for uplink and/or downlink transmissions. The DCI 3510 may indicate second radio resources for a first sidelink transmission. In an example, the second radio resources may be within a second RP, wherein the second RP is configured for sidelink communications. In an example, the second radio resources may comprise radio

resources configured for uplink and/or downlink transmissions. The first RP may be different from the second RP. The DCI 3510 may be a group common DCI. The base station 2405 may transmit one or more DCIs 3520 to the wireless device 2410, wherein the one or more DCIs 3520 may indicate an ID of a wireless device. The one or more DCIs 3520 may indicate the first radio resources for the SCI transmission 3530. The one or more DCIs 3520 may indicate the second radio resources for the first sidelink transmission. The one or more DCIs 3520 may be specific (e.g., UE-specific) DCIs to the wireless device 2410. The wireless device 2410 may determine the ID of the wireless device in the DCI 3520 being the same as a first ID of the wireless device 2410. In response to receiving the DCI 3520, the wireless device 2410 may transmit the SCI 3530 via the first radio resources. The SCI 3530 may indicate the sidelink preemption. The SCI 3530 may indicate the second radio resources for the first sidelink transmission. The SCI 3530 may indicate a first geographic location of the wireless device 2410. The SCI 3530 may indicate a first distance threshold of the first sidelink transmission.

[0257] A wireless device 2415 may receive the SCI 3530 via the first radio resources. In response to receiving the SCI 3530, the wireless device 2415 may determine a conflict of radio resources between third radio resources and the second radio resources. In an example, a base station may assign the third radio resources, to the wireless device 2415, for a second sidelink transmission. The base station may be the base station 2405. In an example, the wireless device 2415 may determine the third radio resources for the second sidelink transmission. The Tx wireless device 2415 may determine to reduce a transmission power and transmit the sidelink transmission via the third radio resources, in response to receiving the SCI 3530.

[0258] FIG. 36 illustrates an example of a wireless device procedure as per an aspect of an embodiment of the present disclosure. In an example, a second wireless device may be in-coverage of a network. The second wireless device may have a second ID. In an example, a second base station may assign third radio resources, to the second wireless device, for a second sidelink transmission. In an example, the second wireless device may determine the third radio resources for the second sidelink transmission. The second wireless device may receive one or more DCIs from a first base station. The first base station may be the same as the second base station. The one or more DCIs may indicate a sidelink preemption. The one or more DCIs may indicate a first ID of a first wireless device. The one or more DCIs may indicate first radio resources for a SA SCI transmission. The one or more DCIs may indicate second radio resources for a first sidelink transmission. The second wireless device may determine the second ID being different from the first ID based on the one or more DCIs.

The second wireless device may determine whether a conflict of radio resources happens between the first radio resources and the third radio resources. In response to determining the conflict of radio resource between the first radio resources and the third radio resources, the second wireless device may stop the second sidelink transmission via the conflicted radio resources. The second wireless device may monitor the SA SCI via the conflicted radio resources. In response to determining no conflict of radio resource between the first radio resources and the third radio resources, the second wireless device may further determine whether a conflict of radio resources happens between the second radio resources and the third radio resources. In response to determining the conflict of radio resource between the second radio resources and the third radio resources, the second wireless device may monitor the SA SCI via the first radio resources. In response to determining no conflict of radio resource between the second radio resources and the third radio resources, the second wireless device may determine to transmit the second sidelink transmission via the third radio resources.

[0259] FIG. 37 illustrates an example of a wireless device procedure as per an aspect of an embodiment of the present disclosure. In an example, a second wireless device may be in coverage of a network. The second wireless device may have a second ID. In an example, a second base station may assign third radio resources, to the second wireless device, for a second sidelink transmission. In an example, the second wireless device may determine the third radio resources for the second sidelink transmission. The second wireless device may receive one or more DCIs from a first base station. The first base station may be the same as the second base station. The one or more DCIs may indicate a sidelink preemption. The one or more DCIs may indicate a first ID of a first wireless device. The one or more DCIs may indicate second radio resources for a first sidelink transmission. The second wireless device may determine the second ID being different from the first ID based on the one or more DCIs. The second wireless device may determine whether a conflict of radio resources happens between the second radio resources and the third radio resources. In response to determining the conflict of radio resource between the second radio resources and the third radio resources, the wireless device may monitor the SA SCI. In response to determining no conflict of radio resource between the second radio resources and the third radio resources, the second wireless device may determine to transmit the second sidelink transmission via the third radio resources.

[0260] FIG. 38 illustrates an example of a wireless device procedure as per an aspect of an embodiment of the present disclosure. In an example, a second wireless device may be in coverage of a network. In an example, a first base station may assign third radio resources, to

the second wireless device, for a second sidelink transmission. In an example, the second wireless device may determine the third radio resources for the second sidelink transmission. The second wireless device may receive a SCI from a first wireless device. The SCI may indicate a sidelink preemption. The SCI may indicate second radio resources for a first sidelink transmission. The SCI may indicate a first geographic location of the first wireless device. The SCI may indicate a first distance threshold of the first sidelink transmission by the first wireless device, wherein the first distance threshold may be a communication range of the first sidelink transmission. The SCI may be a SA SCI. In response to receiving the SCI, the second wireless device may determine a distance between the first wireless device and the second wireless device based on the first geographic location and a second geographic location of the second wireless device. The second wireless device may determine a second distance threshold of the second sidelink transmission. In an example, the second distance threshold may be a communication range of the second sidelink transmission. In an example, the second wireless device may determine the second distance threshold based on the propagation pathloss of the second sidelink transmission given a transmission power by the second wireless device. The second wireless device may compare the distance with a summation of the first distance threshold and the second distance threshold. In an example, in response to the distance being larger than or equal to the summation of the first distance threshold and the second distance threshold, the second wireless device may transmit the second sidelink transmission via the third radio resources. In an example, in response to the distance being smaller than the summation of the first distance threshold and the second distance threshold, the second wireless device may transmit a request to a second base station for requesting fourth radio resources for the second sidelink transmission when the second wireless device is in-coverage of the second base station. In an example, in response to the distance being smaller than the summation of the first distance threshold and the second distance threshold, the second wireless device may reduce a transmission power and transmit the second sidelink transmission via the third radio resources with the transmission power.

[0261] FIG. 39 illustrates an example of a wireless device procedure as per an aspect of an embodiment of the present disclosure. In an example, a second wireless device may be in-coverage of a network. In an example, the second wireless device may be out-of-coverage of the network. In an example, a first base station may assign third radio resources, to the second wireless device, for a second sidelink transmission. In an example, the second wireless device may determine the third radio resources for the second sidelink transmission. The second wireless device may receive a SCI from a first wireless device. The SCI may

indicate a sidelink preemption. The SCI may indicate second radio resources for a first sidelink transmission. The SCI may indicate a first geographic location of the first wireless device. The SCI may indicate a first distance threshold of the first sidelink transmission by the first wireless device, wherein the first distance threshold may be a communication range of the first sidelink transmission. The SCI may be a SA SCI. In response to receiving the SCI, the second wireless device may determine whether a conflict of radio resources happens between the second radio resources and the third radio resources. In response to determining no conflict of radio resources between the second radio resources and the third radio resources, the second wireless device may transmit the second sidelink transmission via the third radio resources. In response to determining the conflict of radio resources between the second radio resources and the third radio resources, the second wireless device may determine a distance between the first wireless device and the second wireless device based on the first geographic location and a second geographic location of the second wireless device. The second wireless device may determine a second distance threshold of the second sidelink transmission. In an example, the second distance threshold may be a communication range of the second sidelink transmission. In an example, the second wireless device may determine the second distance threshold based on the propagation pathloss of the second sidelink transmission given a transmission power by the second wireless device. The second wireless device may compare the distance with a summation of the first distance threshold and the second distance threshold. In an example, in response to the distance being larger than or equal to the summation of the first distance threshold and the second distance threshold, the second wireless device may transmit the second sidelink transmission via the third radio resources. In an example, in response to the distance being smaller than the summation of the first distance threshold and the second distance threshold, the second wireless device may transmit a request to a second base station for requesting fourth radio resources for the second sidelink transmission when the second wireless device is in-coverage of the second base station. In an example, in response to the distance being smaller than the summation of the first distance threshold and the second distance threshold, the second wireless device may determine the fourth radio resources for the second sidelink transmission when the second wireless device is out-of-coverage of a network. In an example, in response to the distance being smaller than the summation of the first distance threshold and the second distance threshold, the second wireless device may reduce a transmission power and transmit the second sidelink transmission via the third radio resources with the transmission power.

[0262] FIG. 40 illustrates an example of a group common DCI as per an aspect of an embodiment of the present disclosure. A group common DCI for sidelink preemption may indicate a sidelink preemption. For example, a format of the group common DCI may implicitly indicate the sidelink preemption. For example, a sequence (e.g., a RNTI for indicating sidelink preemption) may scramble a CRC of the group common DCI for implicitly indicating the sidelink preemption. For example, the group common DCI may comprise a field for explicitly indicating the sidelink preemption. The group common DCI for sidelink preemption may indicate first radio resources for a SA SCI transmission. For example, the group common DCI may comprise a field for indicating resource assignment of the first radio resources. The group common DCI for sidelink preemption may indicate second radio resources for a sidelink transmission. For example, the group common DCI may comprise a field for indicating resource assignment of the second radio resources. The group common DCI for sidelink preemption may indicate an ID of a wireless device. For example, the group common DCI may comprise a field for indicating the ID of the wireless device.

[0263] In an example, a DCI for sidelink preemption may be a specific DCI to a wireless device. The DCI may not be a group common DCI (e.g., the DCI may not be broadcasted to a group of wireless devices). The DCI may indicate a sidelink preemption. For example, a format of the DCI may implicitly indicate the sidelink preemption. For example, a sequence (e.g., a RNTI for indicating sidelink preemption) may scramble a CRC of the DCI for implicitly indicating the sidelink preemption. For example, the DCI may comprise a field for explicitly indicating the sidelink preemption. The DCI for sidelink preemption may indicate first radio resources for a SA SCI transmission. For example, the DCI may comprise a field for indicating resource assignment of the first radio resources. The DCI for sidelink preemption may indicate second radio resources for a sidelink transmission. For example, the DCI may comprise a field for indicating resource assignment of the second radio resources. The DCI for sidelink preemption may indicate an ID of a wireless device. For example, the DCI may comprise a field for indicating the ID of the wireless device.

[0264] FIG. 41 illustrates an example of a SCI as per an aspect of an embodiment of the present disclosure. A SCI for sidelink preemption may be a SA SCI. The SCI for sidelink preemption may indicate a sidelink preemption. For example, the SCI may comprise a field indicating a first priority of a first sidelink transmission. A wireless device may select resources for a second sidelink transmission. The second sidelink transmission may have a second priority. In response to receiving the SCI, the wireless device may determine the sidelink preemption based on the priority. In an example, the wireless device may determine the first sidelink transmission preempt the second sidelink transmission, based on that the

first priority is higher than a priority threshold value and the first priority is higher than the second priority. In another example, the wireless device may determine the first sidelink transmission preempt the second sidelink transmission, based on that the first priority is higher than the second priority. The SCI for sidelink preemption may indicate radio resources for a sidelink transmission. For example, the SCI may comprise a field for indicating resource assignment of the second resources for the sidelink transmission. The SCI for sidelink preemption may indicate a geographic location of a wireless device. For example, the SCI may comprise a field for indicating a zone ID of a zone. The wireless device may be geographically located in the zone. The SCI may indicate the geographic location of the wireless device using the field of the zone ID of the zone. The SCI for sidelink preemption may indicate a distance threshold of the sidelink transmission. For example, the SCI may comprise a field for indicating the distance threshold.

[0265] In an example, a wireless device having a first ID may receive one or more DCIs from a base station. The one or more DCIs may indicate a sidelink preemption. The one or more DCIs may indicate first radio resources for transmission of a SCI. The one or more DCIs may indicate second radio resources for transmission of one or more sidelink signals. The one or more DCIs may indicate a second ID of a wireless device. The first wireless device may transmit the SCI via the first radio resources in response to the second ID being the same as the first ID, wherein the SCI may indicate the sidelink preemption and the second radio resources for the one or more sidelink signals. The first wireless device may transmit the one or more sidelink signals via the second radio resources. In an example, at least one DCI of the one or more DCIs is a group common DCI. In an example, the first radio resources may comprise uplink and/or downlink resources out of a RP. In an example, the second radio resources may comprise uplink and/or downlink resources out of a RP. In an example, the SCI may be a SA SCI.

[0266] In an example, a wireless device having a first ID may receive one or more DCIs from a base station. The one or more DCIs may indicate a sidelink preemption. The one or more DCIs may indicate second radio resources for transmission of one or more sidelink signals. The one or more DCIs may indicate a second ID of a wireless device. The first wireless device may determine first radio resources for transmitting a SCI in response to the second ID being the same as the first ID, wherein the SCI may indicate the sidelink preemption and the second radio resources for the one or more sidelink signals. The first wireless device may transmit the SCI via the first radio resources. The first wireless device may transmit the one or more sidelink signals via the second radio resources. In an example, at least one DCI of the one or more DCIs is a group common DCI. In an example, the first

radio resources may comprise uplink and/or downlink resources out of a RP. In an example, the second radio resources may comprise uplink and/or downlink resources out of a RP. In an example, the SCI may be a SA SCI.

[0267] In an example, a second wireless device may receive one or more SCIs from a first wireless device. The one or more SCIs may indicate a sidelink preemption. The one or more SCIs may indicate first radio resources for transmission of first one or more sidelink signals of the first wireless device. The one or more SCIs may indicate a first geographic location of the first wireless device. The one or more SCIs may indicate a first distance threshold for the transmission of the first one or more sidelink signals. The second wireless device may determine a radio resource conflict between second radio resources, for transmission of second one or more sidelink signals of the second wireless device, and the first radio resources. The second wireless device may stop the transmission of the second sidelink signals via the second radio resources based on the first geographic location, the first distance threshold, a second geographic location of the second wireless device, and a second distance threshold for the transmission of signals of the second wireless device. In an example, at least one SCI of the one or more SCIs is a SA SCI. In an example, the second wireless device may determine a distance between the first wireless device and the second wireless device based on the first geographic location and the second geographic location. In an example, the second wireless device may transmit the second sidelink signals via the second radio resources in response to the distance being larger than or equal to a summation of the first distance threshold and the second distance threshold. In an example, the second wireless device may transmit, to a base station, a request for requesting fourth radio resources for transmitting the second sidelink signals in response to the distance being smaller than the summation of the first distance threshold and the second distance threshold. In an example, the second wireless device may select the fourth radio resources for transmitting the second sidelink signals in response to the distance being smaller than the summation of the first distance threshold and the second distance threshold. In an example, the second wireless device may reduce a transmission power for transmitting the second sidelink signals in response to the distance being smaller than the summation of the first distance threshold and the second distance threshold. The second wireless device may transmit the second sidelink signals via the second radio resources with the reduced transmission power. In an example, the second wireless device may receive, from the base station, a DCI indicating the sidelink preemption.

[0268] FIG. 42 illustrates a flow diagram of an aspect of an example embodiment of the present disclosure. At 4210, a wireless device may receive, from a base station, one or more

DCI indicating a sidelink preemption. At 4220, the wireless device may transmit SCI, via first radio resources, in response to the sidelink preemption. The SCI may indicate resource assignment of second radio resources. At 4230, the wireless device may transmit a sidelink transmission via the second radio resources.

[0269] According to an example embodiment, the first wireless device may have a first ID. According to an example embodiment, the one or more DCI may indicate the second radio resources. According to an example embodiment, the one or more DCI may indicate a wireless device ID. According to an example embodiment, the wireless device may determine the first radio resources for the SCI based on the sidelink preemption and the wireless device ID being the same as the first ID.

[0270] According to an example embodiment, the one or more DCI may comprise a group common DCI. According to an example embodiment, the SCI may be a standalone SCI of the sidelink transmission. According to an example embodiment, the first radio resources may be in a first sidelink resource pool. According to an example embodiment, the second radio resources may be in the first sidelink resource pool. According to an example embodiment, the second radio resources may be in a second sidelink resource pool.

[0271] According to an example embodiment, the first radio resources may comprise uplink radio resources out of a sidelink resource pool. According to an example embodiment, the first radio resources may comprise downlink radio resources out of a sidelink resource pool. According to an example embodiment, the second radio resources may comprise uplink radio resources out of a sidelink resource pool. According to an example embodiment, the second radio resources may comprise downlink radio resources out of a sidelink resource pool.

[0272] FIG. 43 illustrates a flow diagram of an aspect of an example embodiment of the present disclosure. At 4310, a wireless device may receive, from a base station, one or more DCI. The one or more DCI may indicate a sidelink preemption. The one or more DCI may indicate resource assignment of first radio resources for a SCI transmission. At 4320, the wireless device may transmit the SCI via the first radio resources. The wireless device may transmit the SCI based on the sidelink preemption.

[0273] According to an example embodiment, the first wireless device may have a first ID. According to an example embodiment, the one or more DCI may indicate the second radio resources. According to an example embodiment, the one or more DCI may indicate a wireless device ID. According to an example embodiment, the SCI may indicate resource assignment of the second radio resources. According to an example embodiment, the wireless device may transmit the SCI based on that the wireless device ID is the same as the

first ID. According to an example embodiment, the wireless device may transmit the sidelink transmission via the second radio resources.

[0274] According to an example embodiment, the one or more DCI may comprise a group common DCI. According to an example embodiment, the SCI may be a standalone SCI of the sidelink transmission. According to an example embodiment, the first radio resources may be in a first sidelink resource pool. According to an example embodiment, the second radio resources may be in the first sidelink resource pool. According to an example embodiment, the second radio resources may be in a second sidelink resource pool.

[0275] According to an example embodiment, the first radio resources may comprise uplink radio resources out of a sidelink resource pool. According to an example embodiment, the first radio resources may comprise downlink radio resources out of a sidelink resource pool. According to an example embodiment, the second radio resources may comprise uplink radio resources out of a sidelink resource pool. According to an example embodiment, the second radio resources may comprise downlink radio resources out of a sidelink resource pool.

[0276] FIG. 44 illustrates a flow diagram of an aspect of an example embodiment of the present disclosure. At 4410, a second wireless device may receive SCI from a first wireless device. The SCI may indicate resource assignment of first radio resources for a first sidelink transmission of the first wireless device. At 4420, the second wireless device may determine a sidelink preemption. The second wireless device may determine the sidelink preemption based on a first priority of the first sidelink transmission being higher than a second priority of a second sidelink transmission of the second wireless device. The second wireless device may determine the sidelink preemption further based on the first radio resources overlap with second radio resources of the second sidelink transmission. At 4430, the second wireless device may transmit, to a base station, a request for third radio resources for the second sidelink transmission. The second wireless device may transmit the request based on the sidelink preemption.

[0277] According to an example embodiment, the SCI may indicate a first geographic location of the first wireless device. According to an example embodiment, the SCI may indicate a first distance threshold for the first sidelink transmission. According to an example embodiment, the transmission of the request may be further based on the first geographic location and/or the first distance threshold. According to an example embodiment, the first wireless device may be positioned in a zone. According to an example embodiment, a zone identifier of the zone, may indicate the first geographic location.

[0278] According to an example embodiment, the SCI may be a standalone SCI. According to an example embodiment, the SCI may be in a first sidelink resource pool. According to an

example embodiment, the first radio resources may be in a second sidelink resource pool. According to an example embodiment, the second wireless device may determine a distance between the first wireless device and the second wireless device based on the first geographic location and/or a second geographic location of the second wireless device. According to an example embodiment, the transmission of the request for the third radio resources may be based on the distance being smaller than a summation of the first distance threshold and a second distance threshold for the second sidelink transmission. According to an example embodiment, the second wireless device may receive, from the base station, DCI indicating the sidelink preemption.

[0279] FIG. 45 illustrates a flow diagram of an aspect of an example embodiment of the present disclosure. At 4510, a second wireless device may receive SCI from a first wireless device. The SCI may indicate resource assignment of first radio resources for a first sidelink transmission of the first wireless device. At 4520, the second wireless device may determine a sidelink preemption. The second wireless device may determine the sidelink preemption based on a first priority of the first sidelink transmission being higher than a second priority of a second sidelink transmission of the second wireless device. The second wireless device may determine the sidelink preemption further based on the first radio resources overlap with second radio resources of the second sidelink transmission. At 4530, the second wireless device may select third radio resources for the second sidelink transmission based on the sidelink preemption. The second wireless device may select third radio resources further based on a distance between the first wireless device and the second wireless device. At 4540, the second wireless device may transmit the second sidelink transmission via the third radio resources.

[0280] According to an example embodiment, the SCI may indicate a first geographic location of the first wireless device and/or a first distance threshold for the first sidelink transmission. According to an example embodiment, the second wireless device may determine the distance based on the first geographic location and/or the first distance threshold. According to an example embodiment, the first wireless device may be positioned in a zone. According to an example embodiment, a zone identifier of the zone may indicate the first geographic location.

[0281] According to an example embodiment, the SCI may be a standalone SCI. According to an example embodiment, the SCI may be in a first sidelink resource pool. According to an example embodiment, the first radio resources may be in a second sidelink resource pool. According to an example embodiment, the selection of the third radio resources may be based on that the distance is smaller than a summation of the first distance threshold and a

second distance threshold for the second sidelink transmission. According to an example embodiment, the second wireless device may receive, from a base station, DCI indicating the sidelink preemption.

[0282] FIG. 46 illustrates a flow diagram of an aspect of an example embodiment of the present disclosure. At 4610, a second wireless device may receive SCI from a first wireless device. The SCI may indicate resource assignment of first radio resources for a first sidelink transmission of the first wireless device. At 4620, the second wireless device may determine a sidelink preemption. The second wireless device may determine the sidelink preemption based on a first priority of the first sidelink transmission being higher than a second priority of a second sidelink transmission of the second wireless device. The second wireless device may determine the sidelink preemption further based on the first radio resources overlap with second radio resources of the second sidelink transmission. At 4630, the second wireless device may determine a transmission power for the second sidelink transmission based on the sidelink preemption. At 4640, the second wireless device may transmit the second sidelink transmission with the transmission power.

[0283] According to an example embodiment, the SCI may indicate a first geographic location of the first wireless device and/or a first distance threshold for the first sidelink transmission. According to an example embodiment, the determination of the transmission power may be based on the first geographic location and/or the first distance threshold. According to an example embodiment, the first wireless device may be positioned in a zone. According to an example embodiment, a zone identifier of the zone may indicate the first geographic location.

[0284] According to an example embodiment, the SCI may be a standalone SCI. According to an example embodiment, the SCI may be in a first sidelink resource pool. According to an example embodiment, the first radio resources may be in a second sidelink resource pool. According to an example embodiment, the second wireless device may determine a distance between the first wireless device and the second wireless device based on the first geographic location and a second geographic location of the second wireless device. According to an example embodiment, the determination of the transmission power may be based on that the distance is smaller than a summation of the first distance threshold and a second distance threshold for the second sidelink transmission. According to an example embodiment, the second wireless device may receive, from a base station, DCI indicating the sidelink preemption.

CLAIMS

What is claimed is:

1. A method comprising:
 - receiving, by a first wireless device having a first identification (ID), one or more downlink control information (DCI) indicating:
 - a sidelink preemption;
 - second radio resources for a sidelink transmission; and
 - a wireless device ID;
 - determining first radio resources for sidelink control information (SCI) in response to:
 - the sidelink preemption; and
 - the wireless device ID being the same as the first ID, wherein the SCI indicates the second radio resources;
 - transmitting the SCI via the first radio resources; and
 - transmitting the sidelink transmission via the second radio resources.
2. A method comprising:
 - receiving, by a first wireless device having a first identification (ID), one or more downlink control information (DCI) indicating:
 - a sidelink preemption;
 - second radio resources for a sidelink transmission; and
 - the first ID;
 - transmitting, via first resources, sidelink control information (SCI) in response to the one or more DCI, wherein the SCI indicates the second radio resources; and
 - transmitting the sidelink transmission via the second radio resources.
3. A method comprising:
 - receiving, by a first wireless device, one or more downlink control information (DCI) indicating a sidelink preemption;
 - transmitting, via first radio resources, sidelink control information (SCI) in response to the sidelink preemption, wherein the SCI indicates second radio resources; and
 - transmitting a sidelink transmission via the second radio resources.
4. The method of claim 3, wherein the first wireless device has a first identification (ID).
5. The method of any one of claims 3 and 4, wherein the one or more DCI further indicate:
 - the second radio resources; and
 - a wireless device ID.

6. The method of claim 5, further comprising determining the first radio resources for the SCI based on:
 - the sidelink preemption; and
 - the wireless device ID being the same as the first ID.
7. The method of any claims of 3 to 6, wherein the one or more DCI comprise a group common DCI.
8. The method of any claims of 3 to 7, wherein the SCI is a standalone SCI of the sidelink transmission.
9. The method of any claims of 3 to 8, wherein the first radio resources are in a first sidelink resource pool.
10. The method of any claims of 3 to 9, wherein the second radio resources are in the first sidelink resource pool.
11. The method of any claims of 3 to 9, wherein the second radio resources are in a second sidelink resource pool.
12. The method of any claims of 3 to 11, wherein the first radio resources comprise uplink radio resources out of a sidelink resource pool.
13. The method of any claims of 3 to 11, wherein the first radio resources comprise downlink radio resources out of a sidelink resource pool.
14. The method of any claims of 3 to 11, wherein the second radio resources comprise uplink radio resources out of a sidelink resource pool.
15. The method of any claims of 3 to 11, wherein the second radio resources comprise downlink radio resources out of a sidelink resource pool.
16. A method comprising:
 - receiving, by a first wireless device having a first identification (ID), one or more downlink control information (DCI) indicating:
 - a sidelink preemption;
 - first radio resources for sidelink control information (SCI);
 - second radio resources for a sidelink transmission; and
 - a wireless device ID;
 - in response to the sidelink preemption and the wireless device ID being the same as the first ID, transmitting:
 - the SCI via the first radio resources, wherein the SCI indicates the second radio resources; and
 - the sidelink transmission via the second radio resources.
17. A method comprising:

receiving, by a first wireless device, one or more downlink control information (DCI) indicating:

a sidelink preemption; and

first radio resources for sidelink control information (SCI); and

transmitting the SCI via the first radio resources based on the sidelink preemption.

18. The method of claim 17, wherein the first wireless device has a first identification (ID).
19. The method of any claims of 17 and 18, wherein the one or more DCI further indicate:
 - second radio resources for a sidelink transmission; and
 - a wireless device ID.
20. The method of any claims of 17 to 19, wherein the SCI indicates resource assignment of the second radio resources.
21. The method of any claims of 19 and 20, wherein the transmitting the SCI is further based on the wireless device ID being the same as the first ID.
22. The method of any claims of 17 to 21, further comprising transmitting the sidelink transmission via the second radio resources.
23. The method of any claims of 17 to 22, wherein the one or more DCI comprise a group common DCI.
24. The method of any claims of 19 to 23, wherein the SCI is a standalone SCI of the sidelink transmission.
25. The method of any claims of 17 to 24, wherein the first radio resources are in a first sidelink resource pool.
26. The method of any claims of 19 to 25, wherein the second radio resources are in the first sidelink resource pool.
27. The method of any claims of 19 to 25, wherein the second radio resources are in a second sidelink resource pool.
28. The method of any claims of 19 to 27, wherein the first radio resources comprise uplink radio resources out of a sidelink resource pool.
29. The method of any claims of 19 to 27, wherein the first radio resources comprise downlink radio resources out of a sidelink resource pool.
30. The method of any claims of 19 to 27, wherein the second radio resources comprise uplink radio resources out of a sidelink resource pool.
31. The method of any claims of 19 to 27, wherein the second radio resources comprise downlink radio resources out of a sidelink resource pool.
32. A method comprising:

receiving, by a second wireless device from a first wireless device, standalone sidelink control information (SCI) indicating:

first radio resources for a first sidelink transmission of the first wireless device;

a zone identifier of a zone, wherein the first wireless device is positioned,

indicating a first geographic location of the first wireless device; and

a first distance threshold for the first sidelink transmission;

determining a sidelink preemption based on:

a first priority of the first sidelink transmission being higher than a second

priority of a second sidelink transmission of the second wireless device; and

the first radio resources overlap with second radio resources of the second sidelink transmission; and

transmitting, by the second wireless device to a base station and based on the sidelink preemption, a request for third radio resources for the second sidelink transmission, based on:

the zone identifier; and

the first distance threshold.

33. A method comprising:

receiving, by a second wireless device from a first wireless device, sidelink control information (SCI) indicating:

first radio resources for a first sidelink transmission of the first wireless device;

a first geographic location of the first wireless device; and

a first distance threshold for the first sidelink transmission;

determining a sidelink preemption based on:

a first priority of the first sidelink transmission being higher than a second priority of a second sidelink transmission of the second wireless device; and

the first radio resources overlap with second radio resources of the second sidelink transmission; and

transmitting, by the second wireless device to a base station and based on the sidelink preemption, a request for third radio resources for the second sidelink transmission, based on:

the first geographic location; and

the first distance threshold.

34. A method comprising:

receiving, by a second wireless device from a first wireless device, sidelink control information (SCI) indicating first radio resources for a first sidelink transmission of the first wireless device;

determining a sidelink preemption based on:

a first priority of the first sidelink transmission being higher than a second priority of a second sidelink transmission of the second wireless device; and
the first radio resources overlap with second radio resources of the second sidelink transmission; and

transmitting, by the second wireless device to a base station and based on the sidelink preemption, a request for third radio resources for the second sidelink transmission.

35. The method of claim 34, wherein the SCI further indicates:
 - a first geographic location of the first wireless device; and
 - a first distance threshold for the first sidelink transmission.
36. The method of claim 35, wherein the transmitting the request is further based on:
 - the first geographic location; and
 - the first distance threshold.
37. The method of claim 36, wherein the first wireless device is positioned in a zone.
38. The method of claim 37, wherein a zone identifier, of the zone, indicates the first geographic location.
39. The method of any claims of 34 to 38, wherein the SCI is a standalone SCI.
40. The method of any claims of 34 to 39, wherein the SCI is in a first sidelink resource pool.
41. The method of any claims of 34 to 40, wherein the first radio resources are in a second sidelink resource pool.
42. The method of claim 36, further comprises determining a distance between the first wireless device and the second wireless device based on the first geographic location and a second geographic location of the second wireless device.
43. The method of claim 42, wherein the transmitting the request for the third radio resources is based on the distance being smaller than a summation of the first distance threshold and a second distance threshold for the second sidelink transmission.
44. The method of claim 34 further comprises receiving, from the base station, downlink control information (DCI) indicating the sidelink preemption.
45. A method comprising:
 - receiving, by a second wireless device from a first wireless device, standalone sidelink control information (SCI) indicating:
 - first radio resources for a first sidelink transmission of the first wireless device;

a zone identifier of a zone, wherein the first wireless device is positioned, indicating a first geographic location of the first wireless device; and
a first distance threshold for the first sidelink transmission;

determining a sidelink preemption based on:

a first priority of the first sidelink transmission being higher than a second priority of a second sidelink transmission of the second wireless device; and
the first radio resources overlap with second radio resources of the second sidelink transmission;

selecting, by the second wireless device, third radio resources for the second sidelink transmission based on:

the sidelink preemption;
the zone identifier; and
the first distance threshold; and

transmitting the second sidelink transmission via the third radio resources.

46. A method comprising

receiving, by a second wireless device from a first wireless device, sidelink control information (SCI) indicating:

first radio resources for a first sidelink transmission of the first wireless device;
a first geographic location of the first wireless device; and
a first distance threshold for the first sidelink transmission;

determining a sidelink preemption based on:

a first priority of the first sidelink transmission being higher than a second priority of a second sidelink transmission of the second wireless device; and
the first radio resources overlap with second radio resources of the second sidelink transmission;

selecting, by the second wireless device, third radio resources for the second sidelink transmission based on:

the sidelink preemption;
the first geographic location; and
the first distance threshold; and

transmitting the second sidelink transmission via the third radio resources.

47. A method comprising:

receiving, by a second wireless device from a first wireless device, sidelink control information (SCI) indicating first radio resources for a first sidelink transmission of the first wireless device;

determining a sidelink preemption based on:

a first priority of the first sidelink transmission being higher than a second priority of a second sidelink transmission of the second wireless device; and
the first radio resources overlap with second radio resources of the second sidelink transmission;

selecting, by the second wireless device, third radio resources for the second sidelink transmission based on:

the sidelink preemption; and

a distance between the first wireless device and the second wireless device; and
transmitting the second sidelink transmission via the third radio resources.

48. The method of claim 47, wherein the SCI further indicates:

a first geographic location of the first wireless device; and
a first distance threshold for the first sidelink transmission.

49. The method of claim 48, further comprising determining the distance based on:

the first geographic location; and
the first distance threshold.

50. The method of claim 49, wherein the first wireless device is positioned in a zone.

51. The method of claim 50, wherein a zone identifier, of the zone, indicates the first geographic location.

52. The method of any claims of 47 to 51, wherein the SCI is a standalone SCI.

53. The method of any claims of 47 to 52, wherein the SCI is in a first sidelink resource pool.

54. The method of any claims of 47 to 53, wherein the first radio resources are in a second sidelink resource pool.

55. The method of any claims of 48 to 54, wherein the selecting the third radio resources is based on the distance being smaller than a summation of the first distance threshold and a second distance threshold for the second sidelink transmission.

56. The method of any claims of 47 to 55 further comprises receiving, from a base station, downlink control information (DCI) indicating the sidelink preemption.

57. A method comprising:

receiving, by a second wireless device from a first wireless device, standalone sidelink control information (SCI) indicating:

first radio resources for a first sidelink transmission of the first wireless device;
a zone identifier of a zone, wherein the first wireless device is positioned,
indicating a first geographic location of the first wireless device; and
a first distance threshold for the first sidelink transmission;

determining a sidelink preemption based on:

a first priority of the first sidelink transmission being higher than a second priority of a second sidelink transmission of the second wireless device; and

the first radio resources overlap with second radio resources of the second sidelink transmission;

determining, by the second wireless device, a transmission power for the second sidelink transmission based on:

the sidelink preemption;

the zone identifier; and

the first distance threshold; and

transmitting the second sidelink transmission with the transmission power.

58. A method comprising:

receiving, by a second wireless device from a first wireless device, sidelink control information (SCI) indicating:

first radio resources for a first sidelink transmission of the first wireless device;

a first geographic location of the first wireless device; and

a first distance threshold for the first sidelink transmission;

determining a sidelink preemption based on:

a first priority of the first sidelink transmission being higher than a second priority of a second sidelink transmission of the second wireless device; and

the first radio resources overlap with second radio resources of the second sidelink transmission;

determining, by the second wireless device, a transmission power for the second sidelink transmission based on:

the sidelink preemption;

the first geographic location; and

the first distance threshold; and

transmitting the second sidelink transmission with the transmission power.

59. A method comprising:

receiving, by a second wireless device from a first wireless device, sidelink control information (SCI) indicating first radio resources for a first sidelink transmission of the first wireless device;

determining a sidelink preemption based on:

a first priority of the first sidelink transmission being higher than a second priority of a second sidelink transmission of the second wireless device; and

- the first radio resources overlap with second radio resources of the second sidelink transmission;
- determining, by the second wireless device and based on the sidelink preemption, a transmission power for the second sidelink transmission; and
- transmitting the second sidelink transmission with the transmission power.
60. The method of claim 59, wherein the SCI further indicates:
- a first geographic location of the first wireless device; and
 - a first distance threshold for the first sidelink transmission.
61. The method of claim 60, wherein the determining the transmission power is further based on:
- the first geographic location; and
 - the first distance threshold.
62. The method of claim 61, wherein the first wireless device is positioned in a zone.
63. The method of claim 62, wherein a zone identifier, of the zone, indicates the first geographic location.
64. The method of any claims of 59 to 63, wherein the SCI is a standalone SCI.
65. The method of any claims of 59 to 64, wherein the SCI is in a first sidelink resource pool.
66. The method of any claims of 59 to 65, wherein the first radio resources are in a second sidelink resource pool.
67. The method of any claims of 61 to 66, further comprises determining a distance between the first wireless device and the second wireless device based on the first geographic location and a second geographic location of the second wireless device.
68. The method of claim 67, wherein the determining the transmission power is based on the distance being smaller than a summation of the first distance threshold and a second distance threshold for the second sidelink transmission.
69. The method of any claims of 59 to 68 further comprises receiving, from a base station, downlink control information (DCI) indicating the sidelink preemption.
70. A wireless device comprising:
- one or more processors; and
 - memory storing instructions that, when executed by the one or more processors, cause the wireless device to perform the method of any one of claims 1 to 69.
71. A non-transitory computer-readable medium comprising instructions that, when executed by one or more processors, cause the one or more processors to perform the method of any one of claims 1 to 69.
72. A system comprising:

a base station comprising:

one or more first processors; and

first memory storing first instructions that, when executed by the one or more first processors, cause the base station to transmit one or more downlink control information (DCI) indicating a sidelink preemption; and

a wireless device comprising:

one or more second processors; and

second memory storing second instructions that, when executed by the one or more second processors, cause the wireless device to:

receive the one or more downlink control information (DCI);

transmit, via first radio resources, sidelink control information (SCI) in response to the sidelink preemption, wherein the SCI indicates second radio resources; and

transmit a sidelink transmission via the second radio resources.

73. A system comprising:

a base station comprising:

one or more first processors; and

first memory storing first instructions that, when executed by the one or more first processors, cause the base station to transmit one or more downlink control information (DCI) indicating:

a sidelink preemption; and

first radio resources for sidelink control information (SCI); and

a wireless device comprising:

one or more second processors; and

second memory storing second instructions that, when executed by the one or more second processors, cause the wireless device to:

receive the one or more downlink control information (DCI); and

transmit the SCI via the first radio resources based on the sidelink preemption.

74. A system comprising:

a base station;

a first wireless device; and

a second wireless device comprising:

one or more second processors; and

second memory storing second instructions that, when executed by the one or more second processors, cause the second wireless device to:

receive, from the first wireless device, sidelink control information (SCI) indicating first radio resources for a first sidelink transmission of the first wireless device;

determine a sidelink preemption based on:

a first priority of the first sidelink transmission being higher than a second priority of a second sidelink transmission of the second wireless device; and

the first radio resources overlap with second radio resources of the second sidelink transmission; and

transmit, to the base station and based on the sidelink preemption, a request for third radio resources for the second sidelink transmission.

75. A system comprising:

a first wireless device; and

a second wireless device comprising:

one or more second processors; and

second memory storing second instructions that, when executed by the one or more second processors, cause the second wireless device to:

receive, from the first wireless device, sidelink control information (SCI) indicating first radio resources for a first sidelink transmission of the first wireless device;

determine a sidelink preemption based on:

a first priority of the first sidelink transmission being higher than a second priority of a second sidelink transmission of the second wireless device; and

the first radio resources overlap with second radio resources of the second sidelink transmission;

select third radio resources for the second sidelink transmission based on:

the sidelink preemption; and

a distance between the first wireless device and the second wireless device; and

transmit the second sidelink transmission via the third radio resources.

76. A system comprising:

a first wireless device; and

a second wireless device comprising:

one or more second processors; and

second memory storing second instructions that, when executed by the one or more second processors, cause the second wireless device to:

receive, from the first wireless device, sidelink control information (SCI) indicating first radio resources for a first sidelink transmission of the first wireless device;

determine a sidelink preemption based on:

a first priority of the first sidelink transmission being higher than a second priority of a second sidelink transmission of the second wireless device; and

the first radio resources overlap with second radio resources of the second sidelink transmission;

determine, by the second wireless device and based on the sidelink preemption, a transmission power for the second sidelink transmission; and transmit the second sidelink transmission with the transmission power.

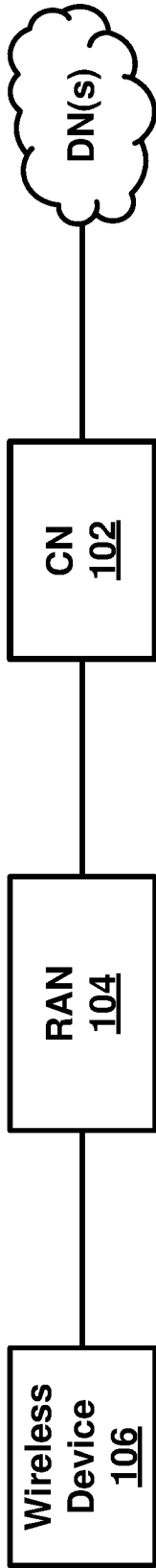

FIG. 1A

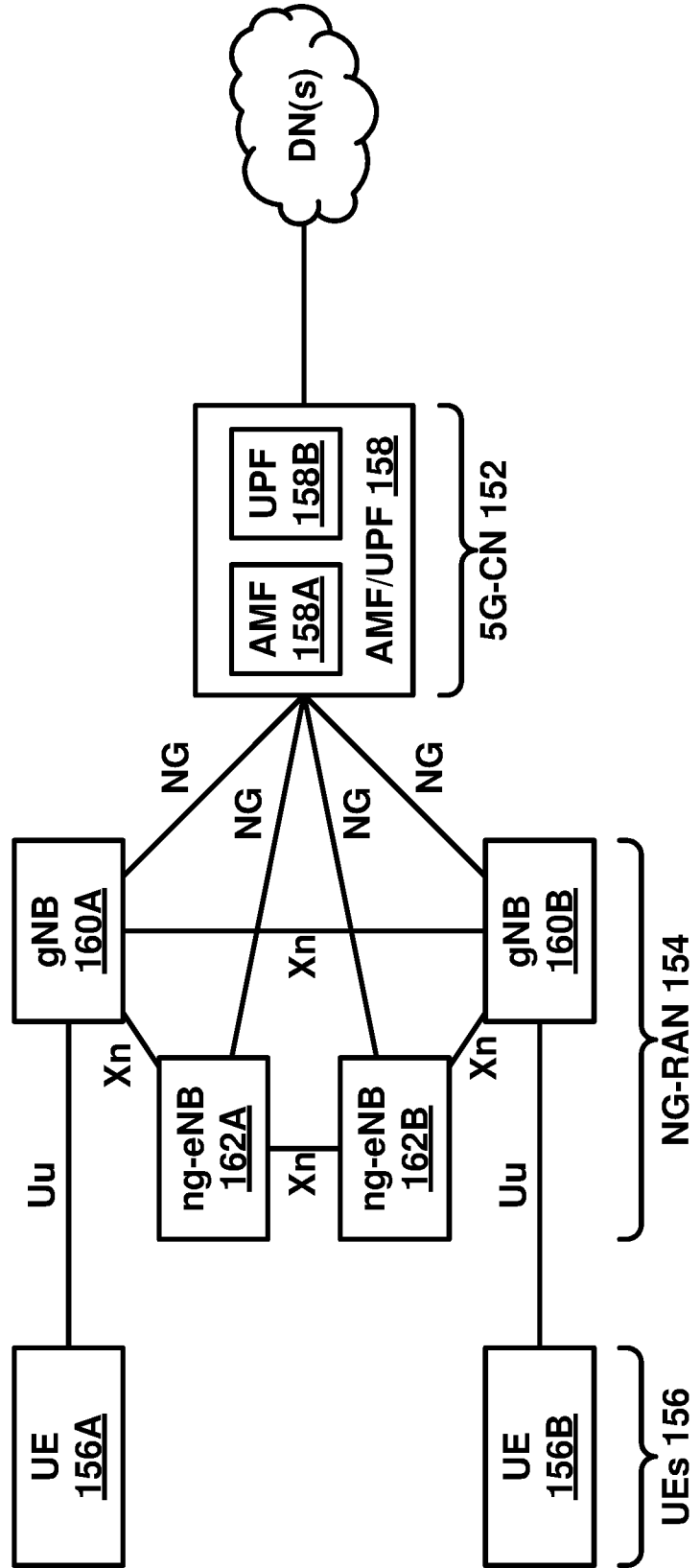

FIG. 1B



2/46

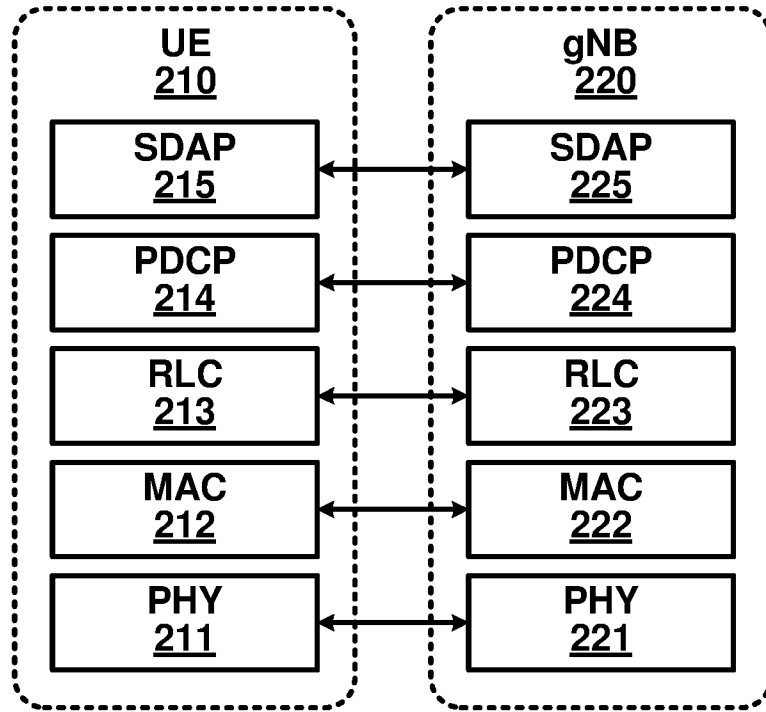

FIG. 2A

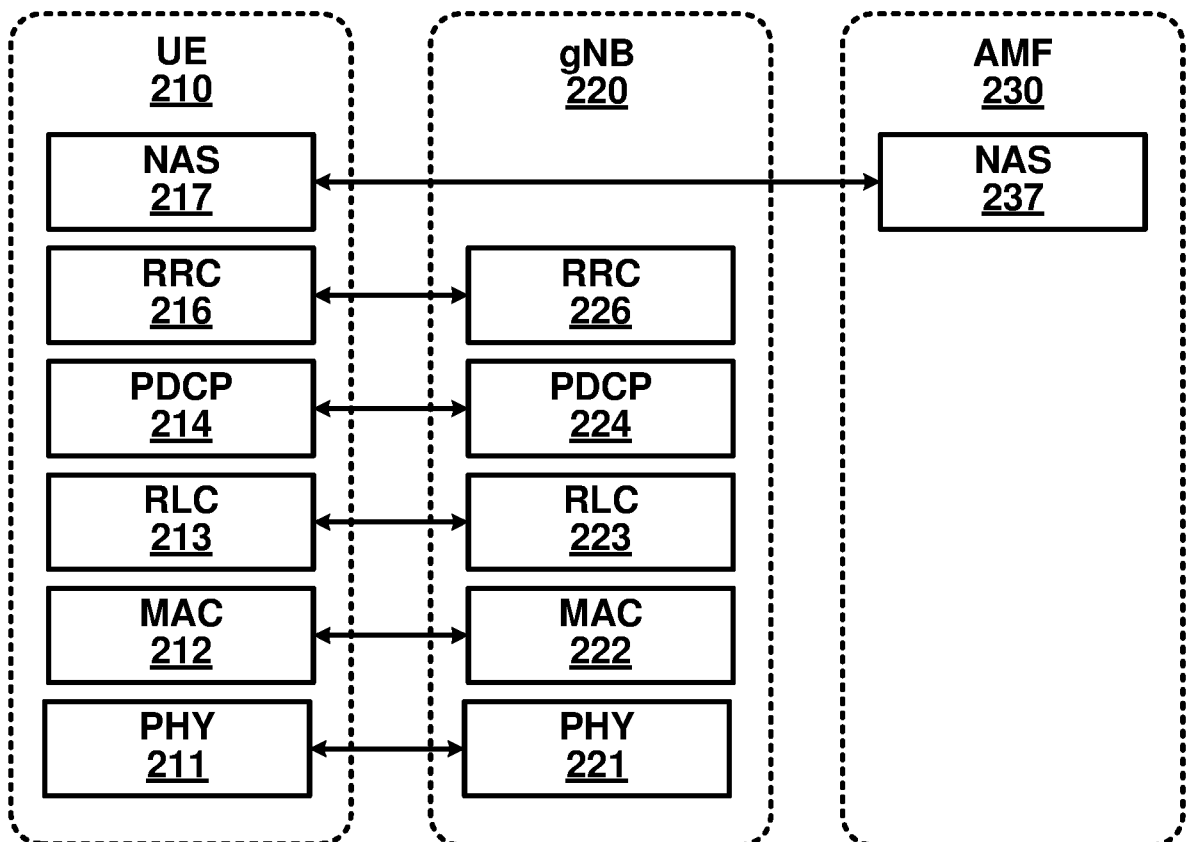

FIG. 2B

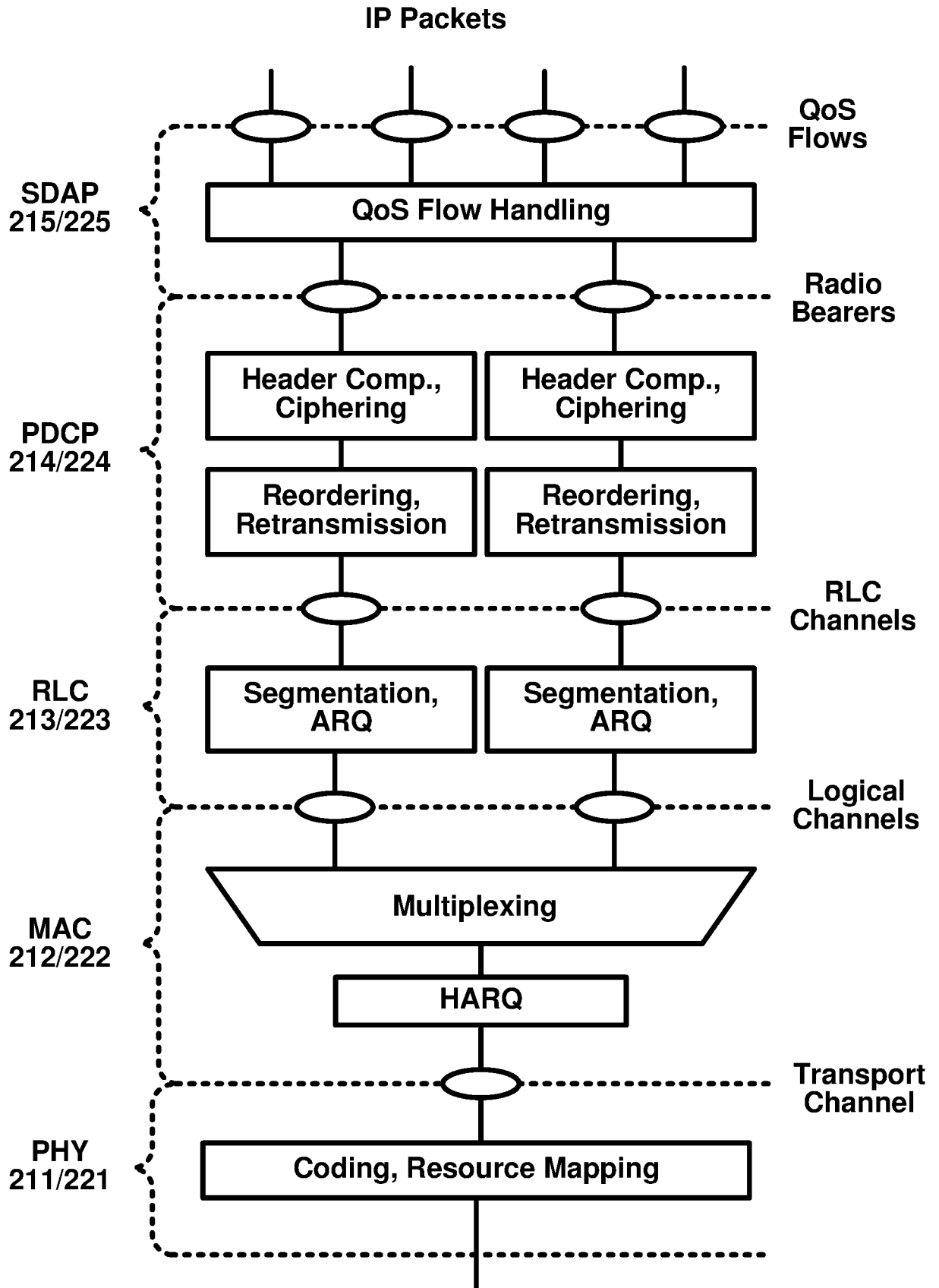

FIG. 3

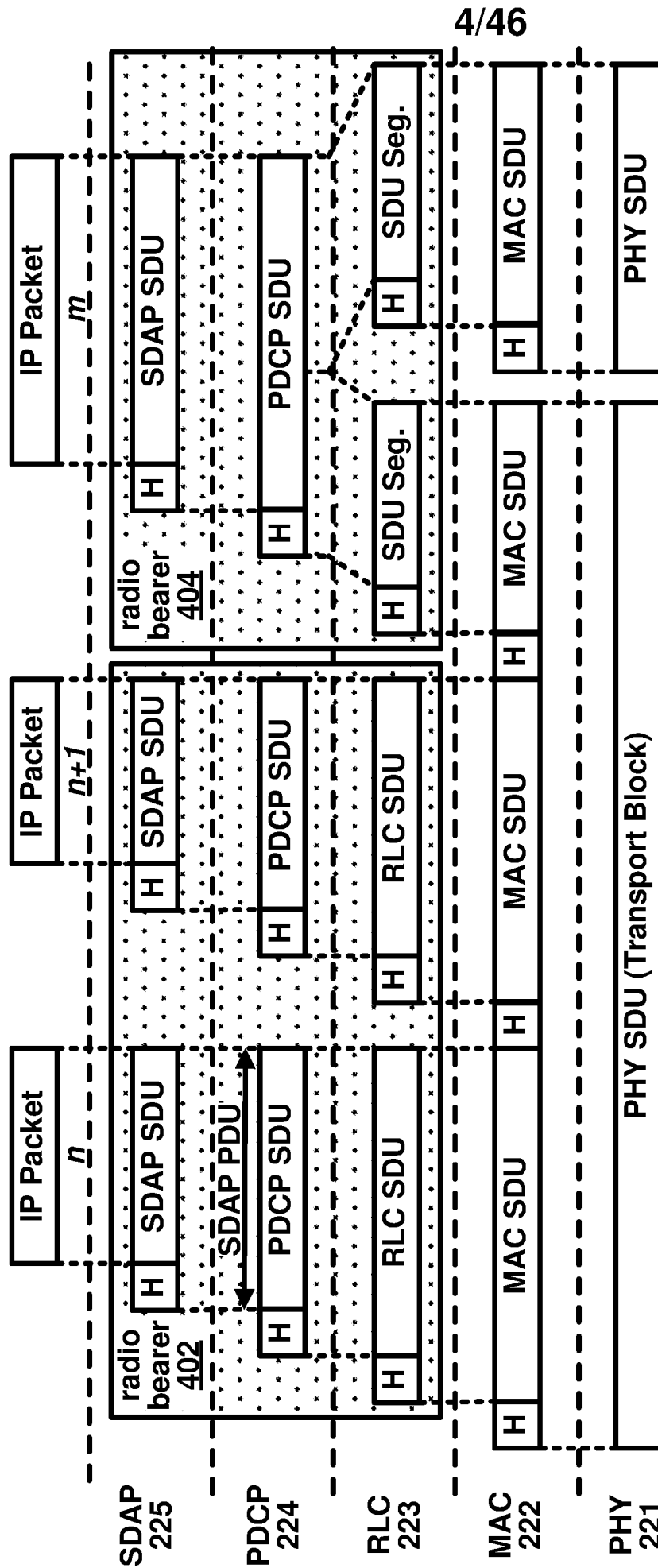

FIG. 4A

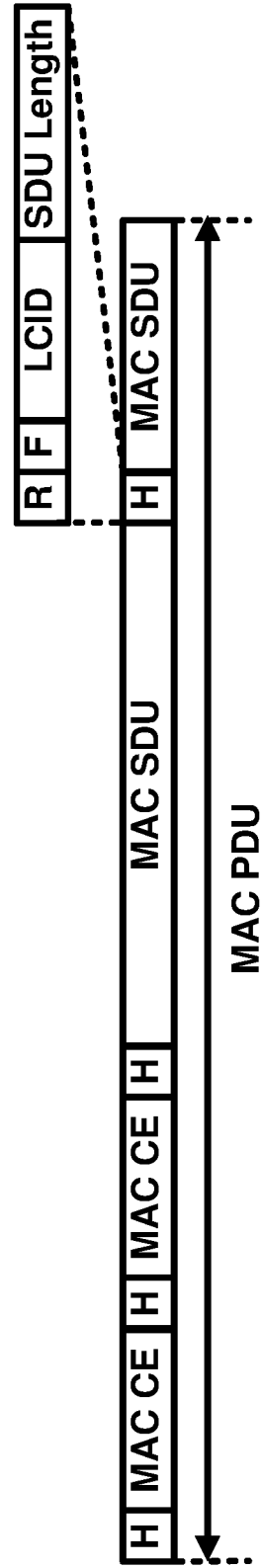

FIG. 4B

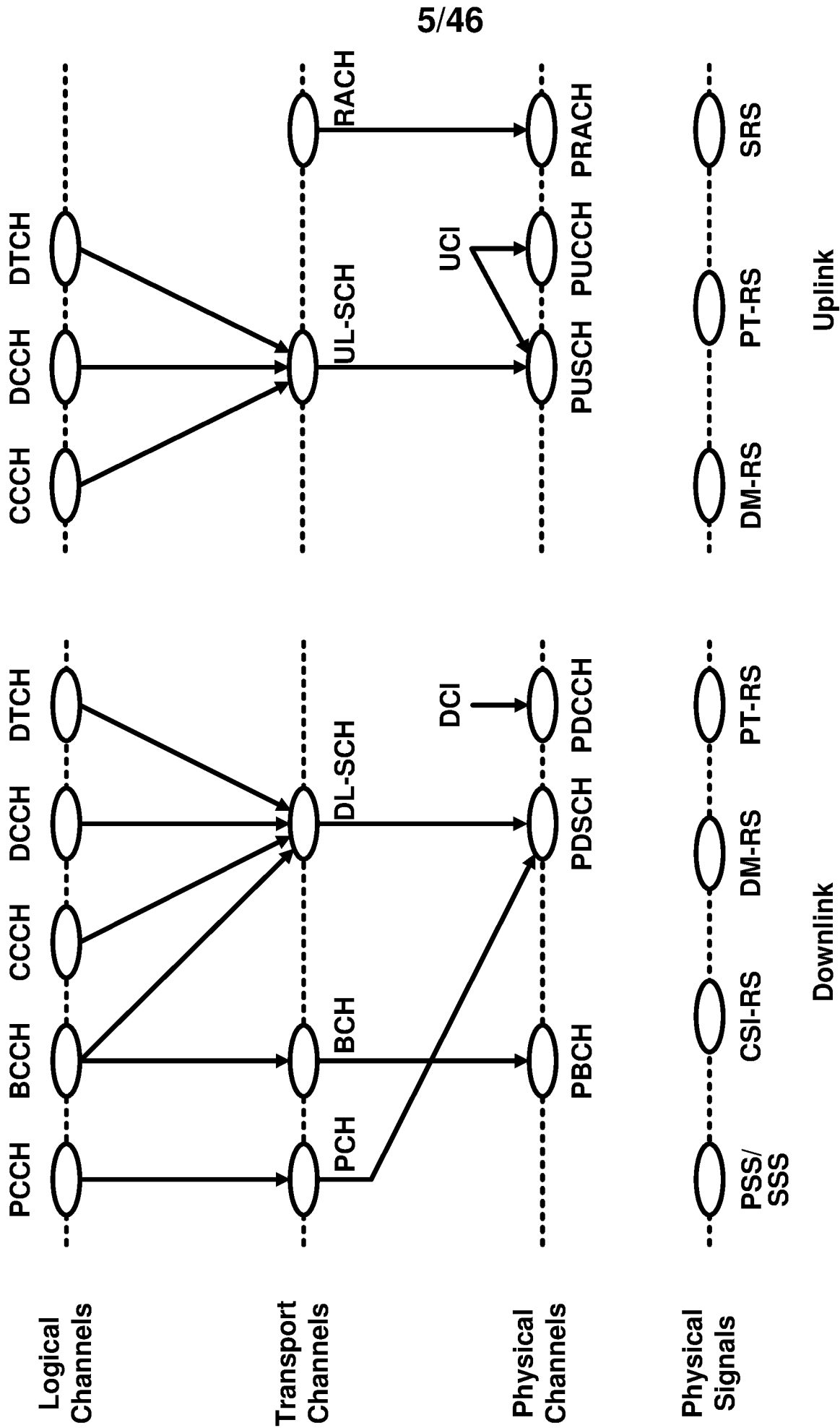

FIG. 5B

FIG. 5A

6/46

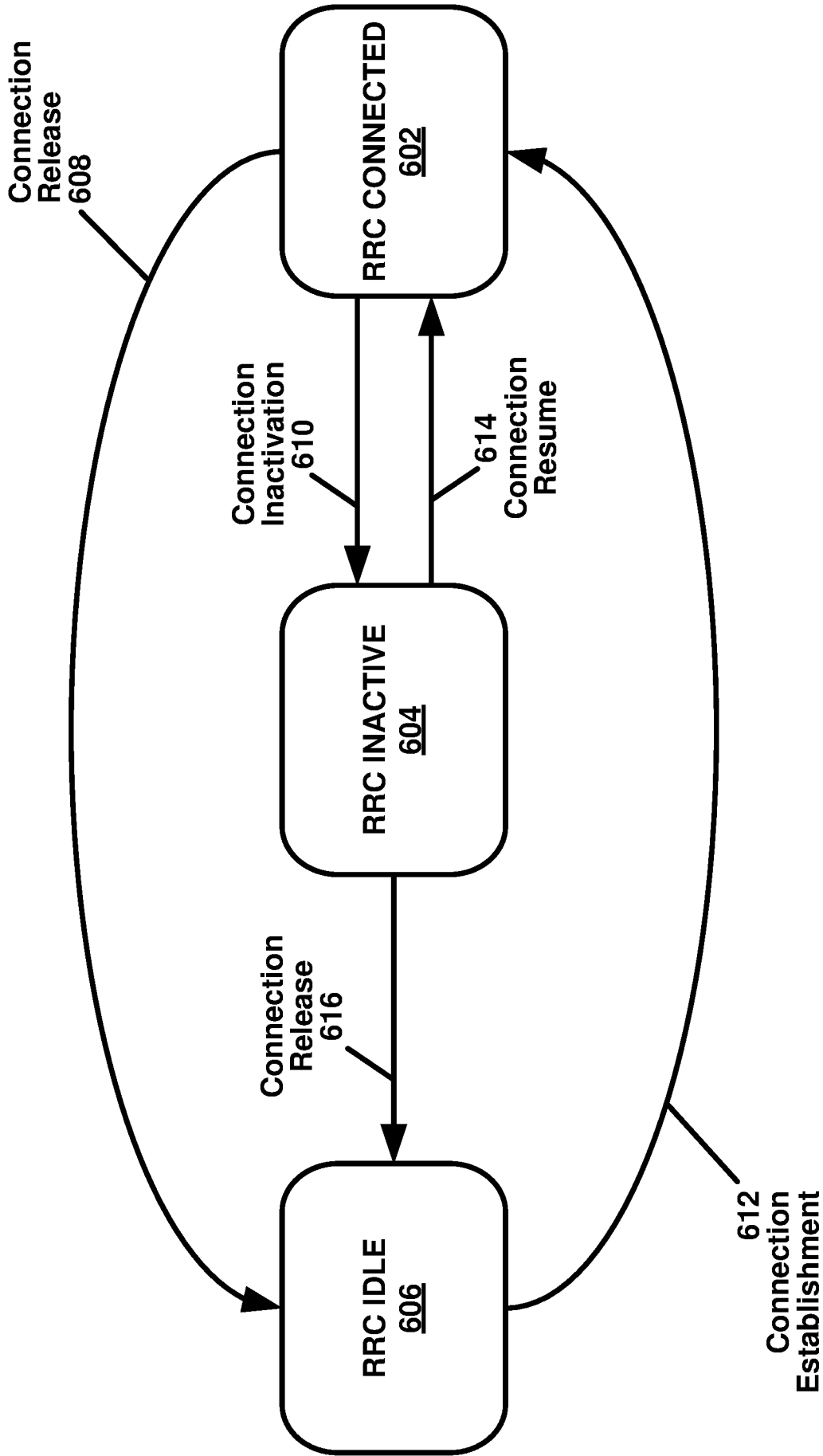

FIG. 6

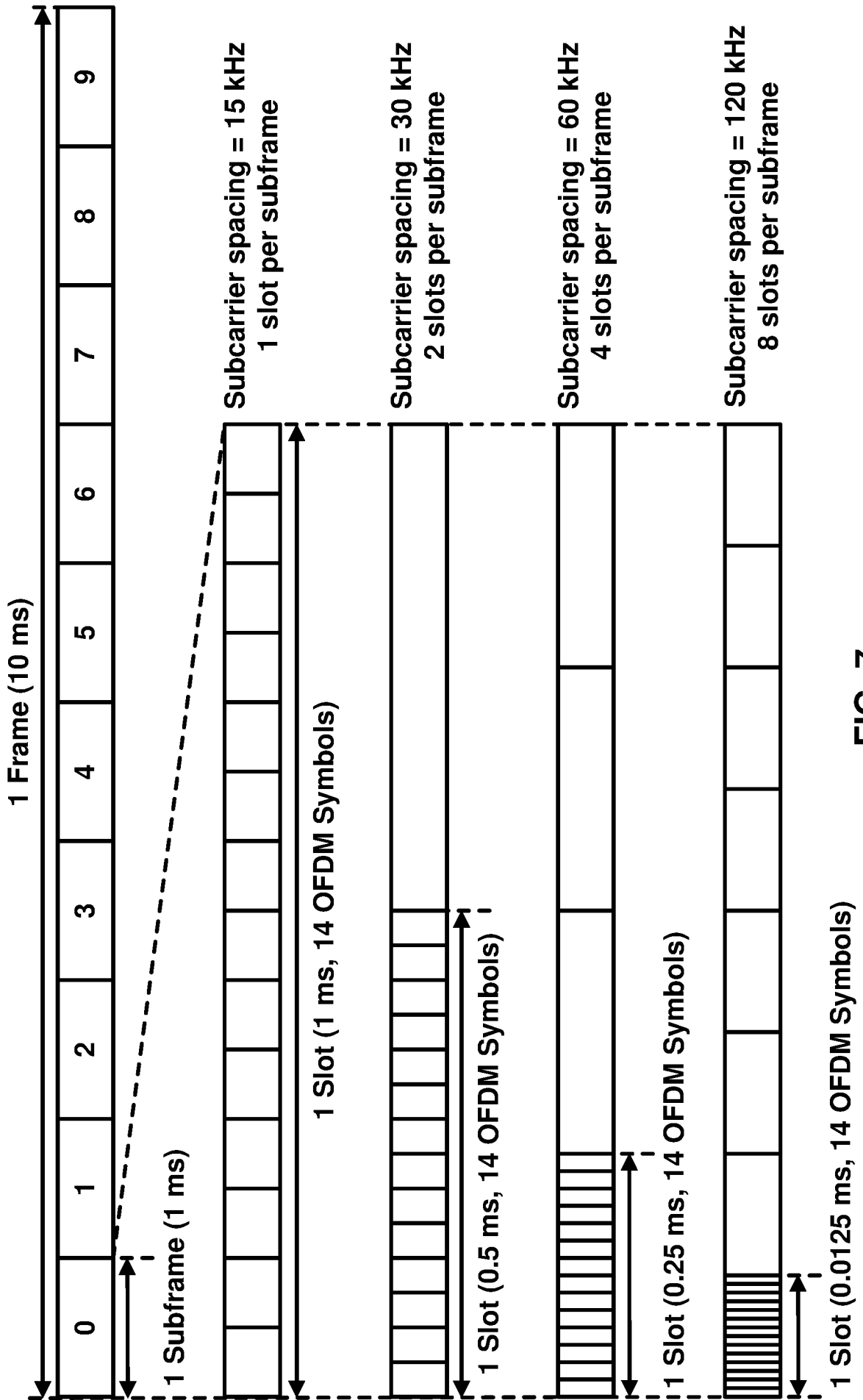

FIG. 7

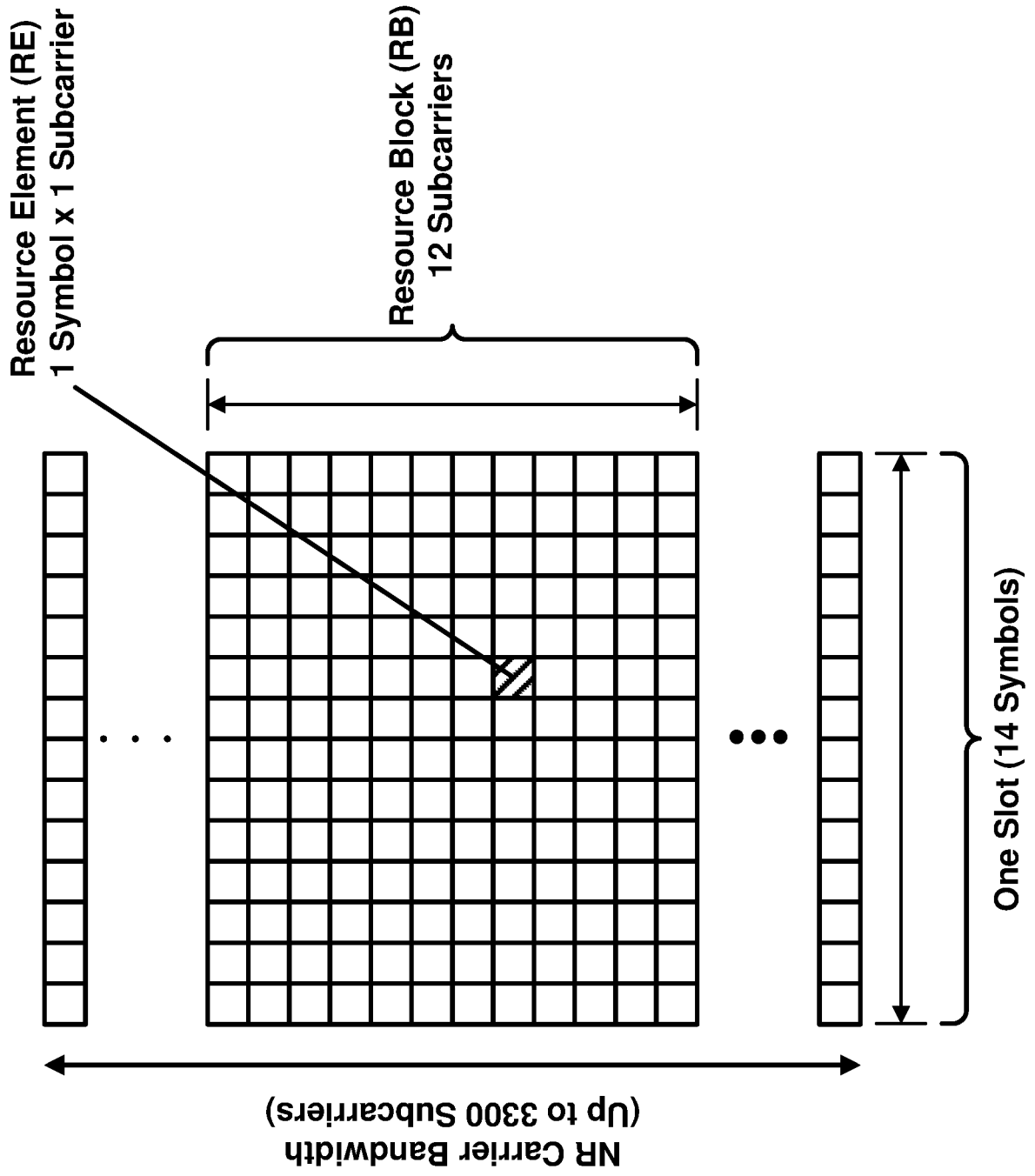

FIG. 8

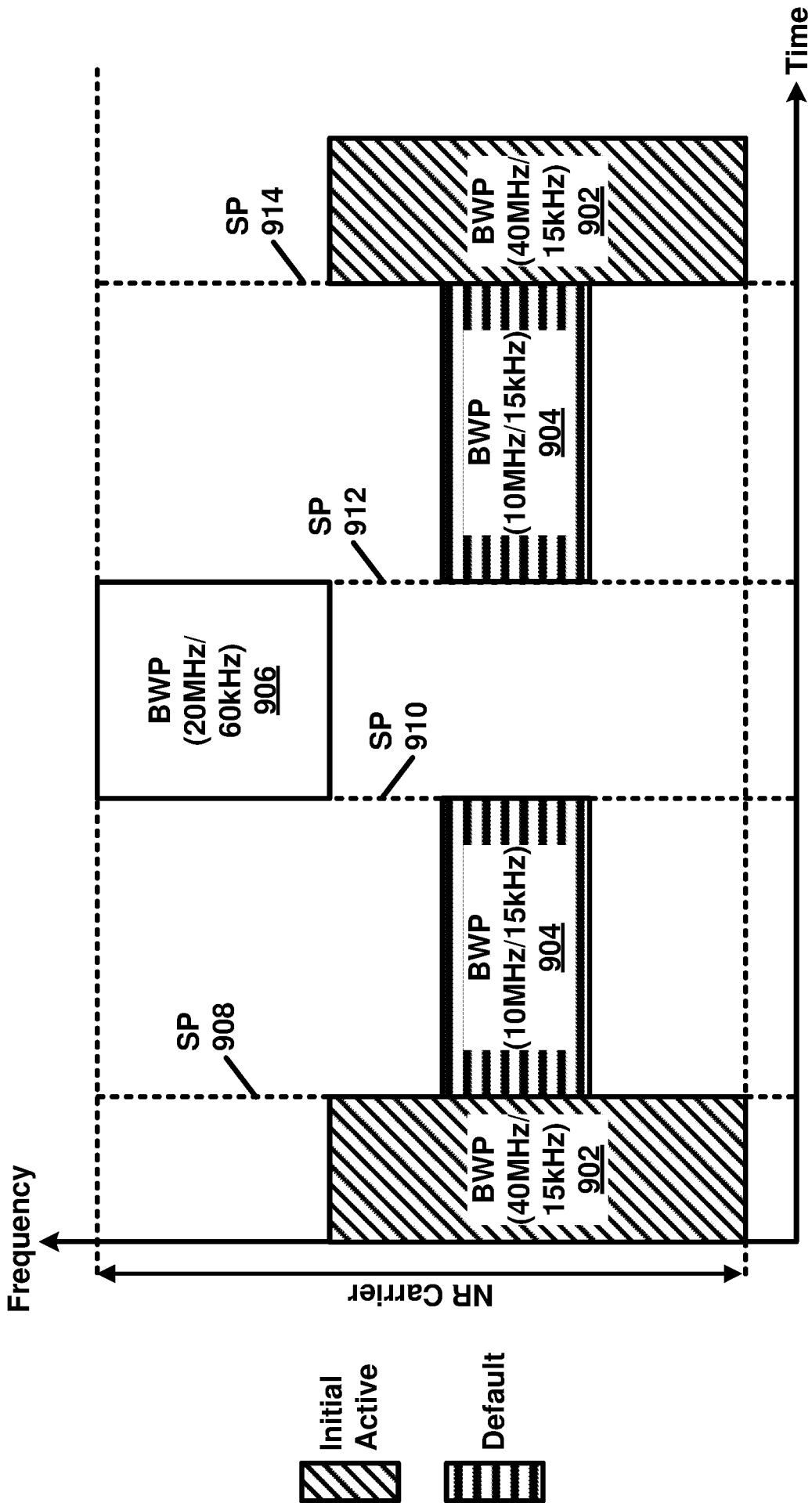

FIG. 9

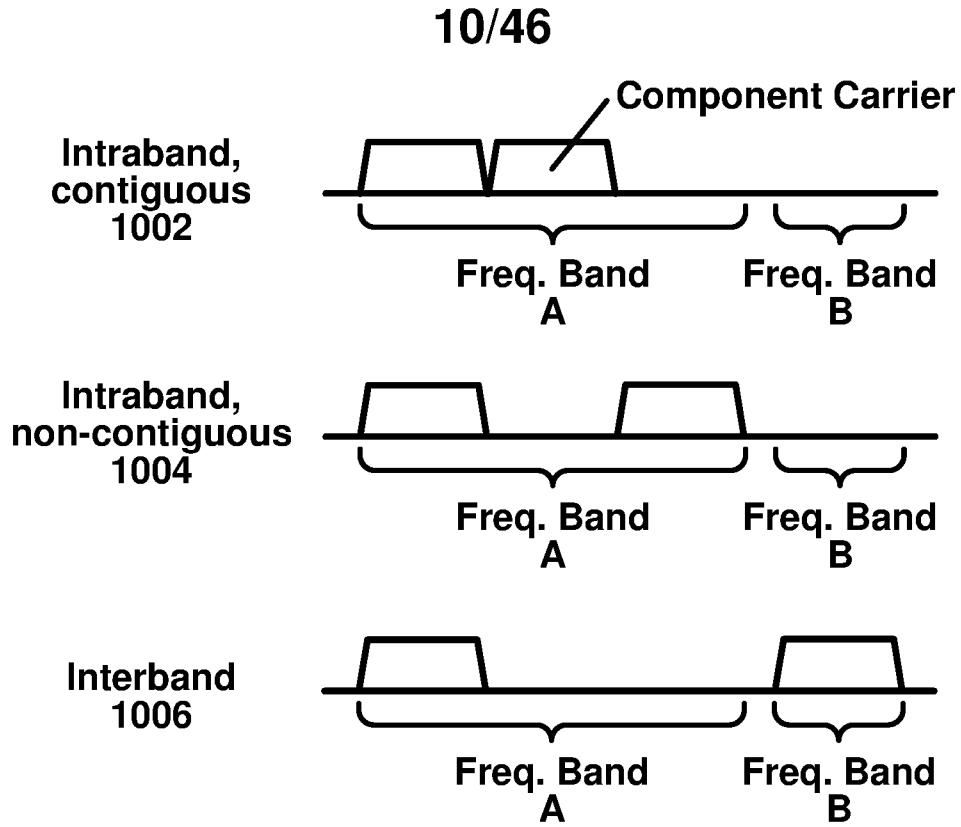

FIG. 10A

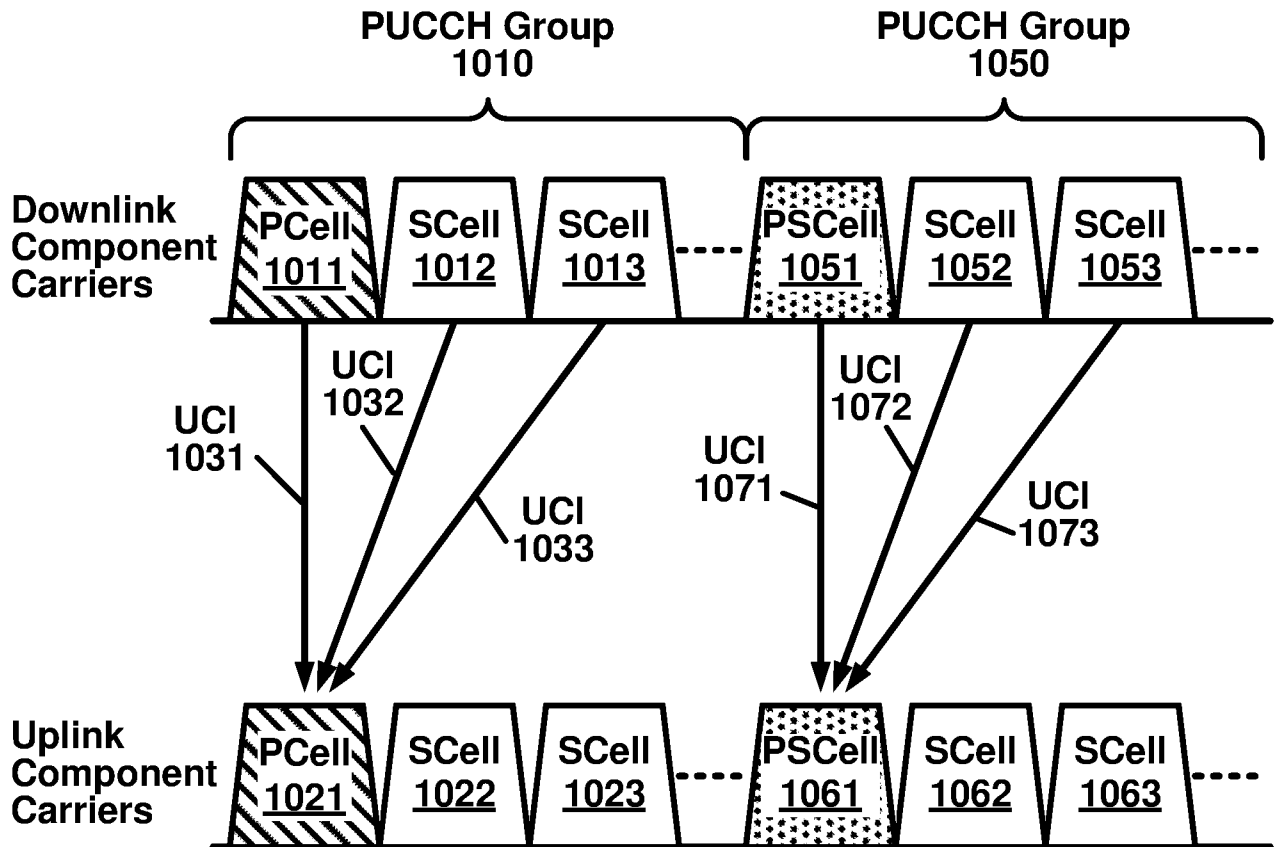

FIG. 10B

11/46

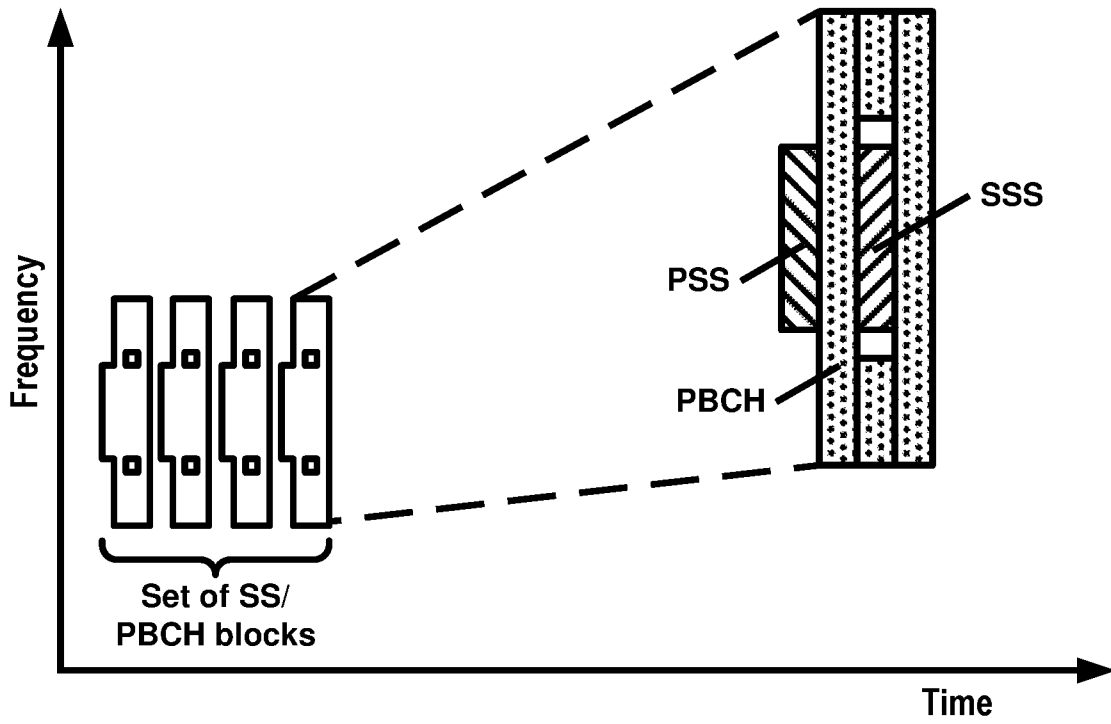

FIG. 11A

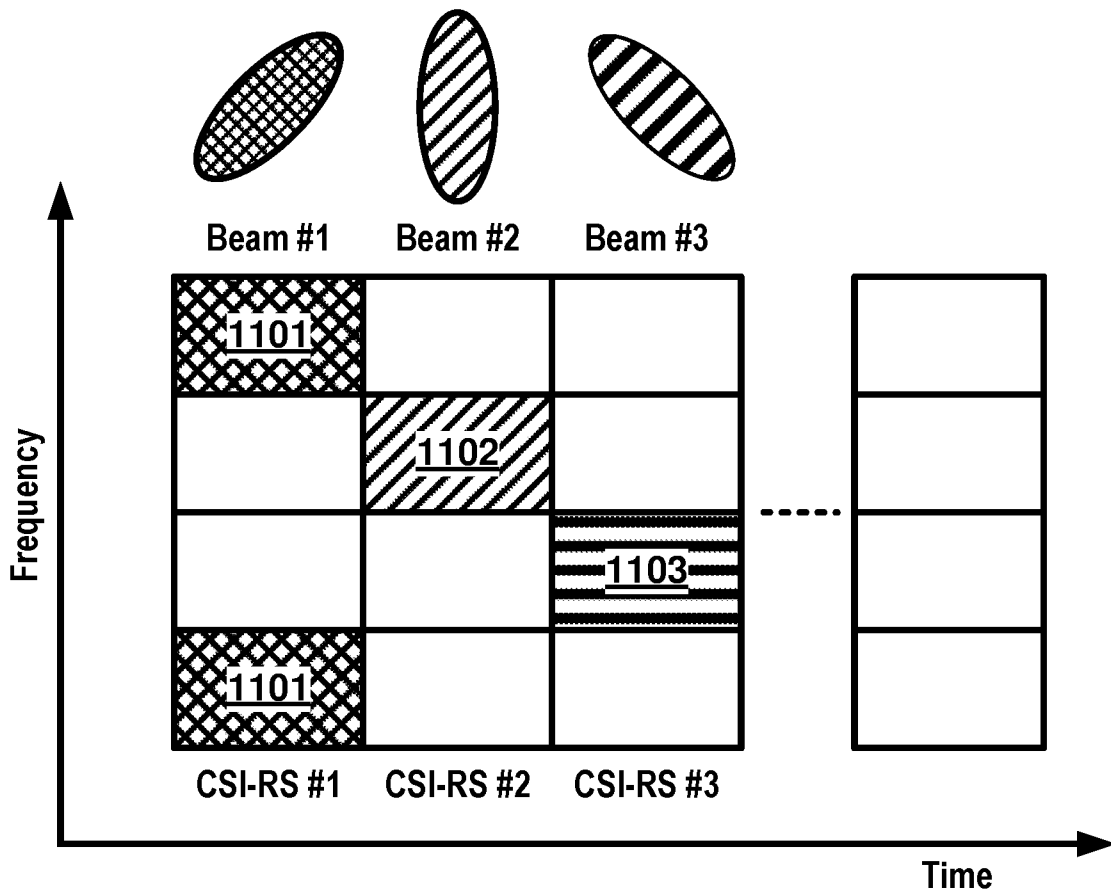

FIG. 11B

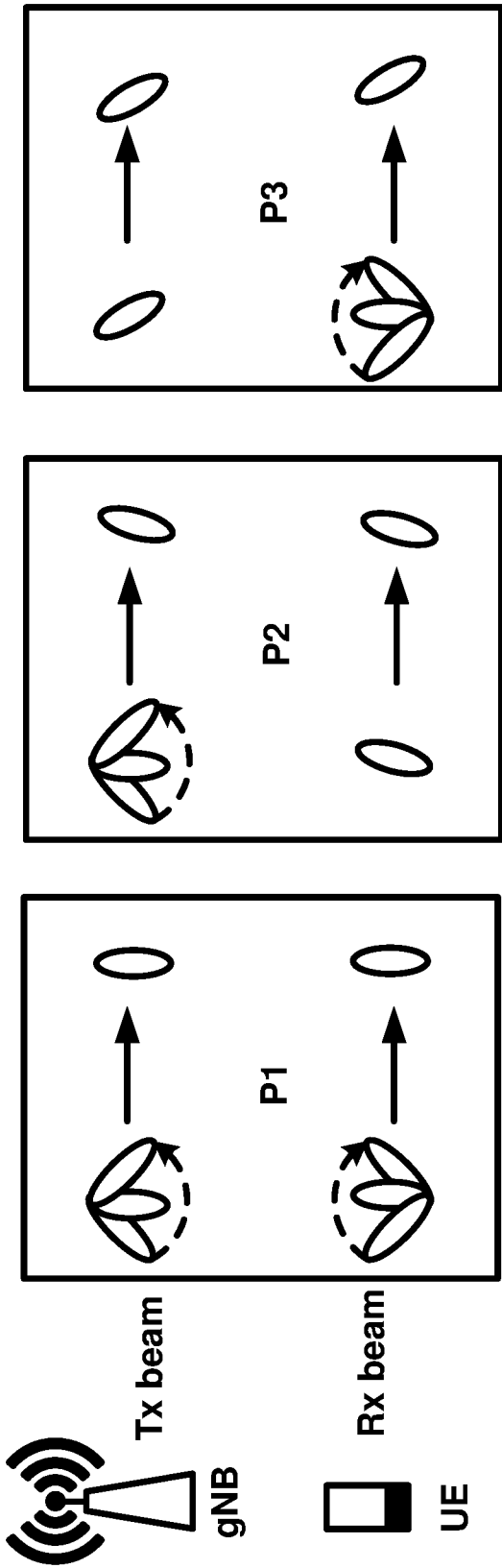

FIG. 12A

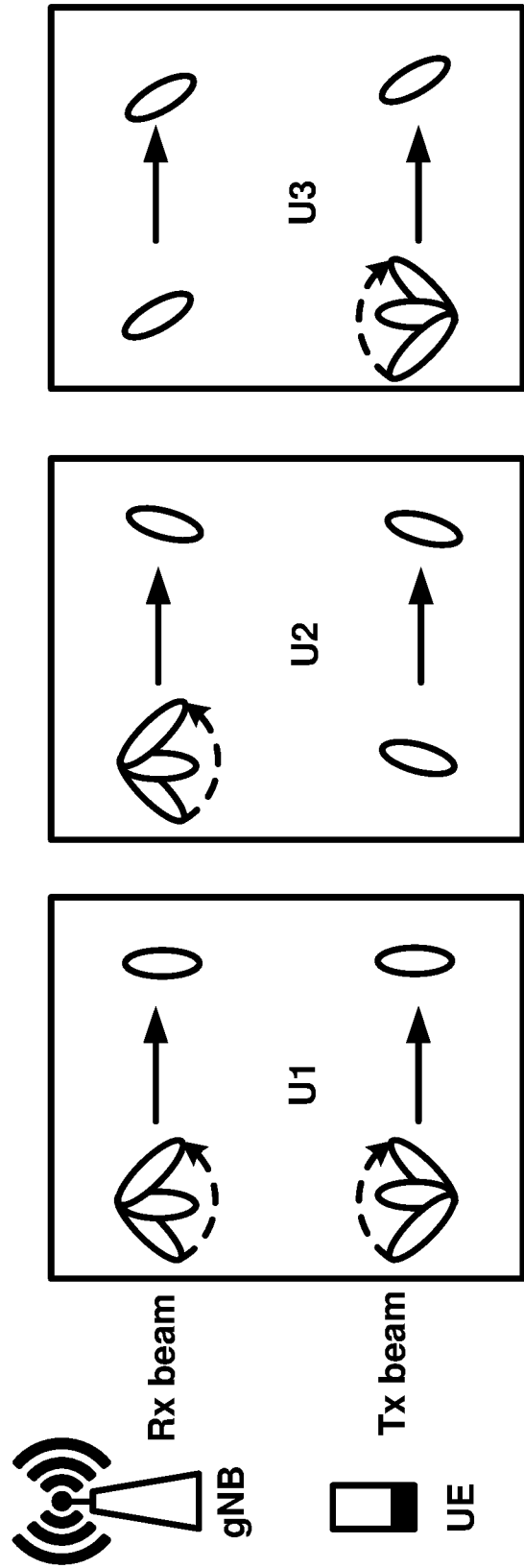

FIG. 12B

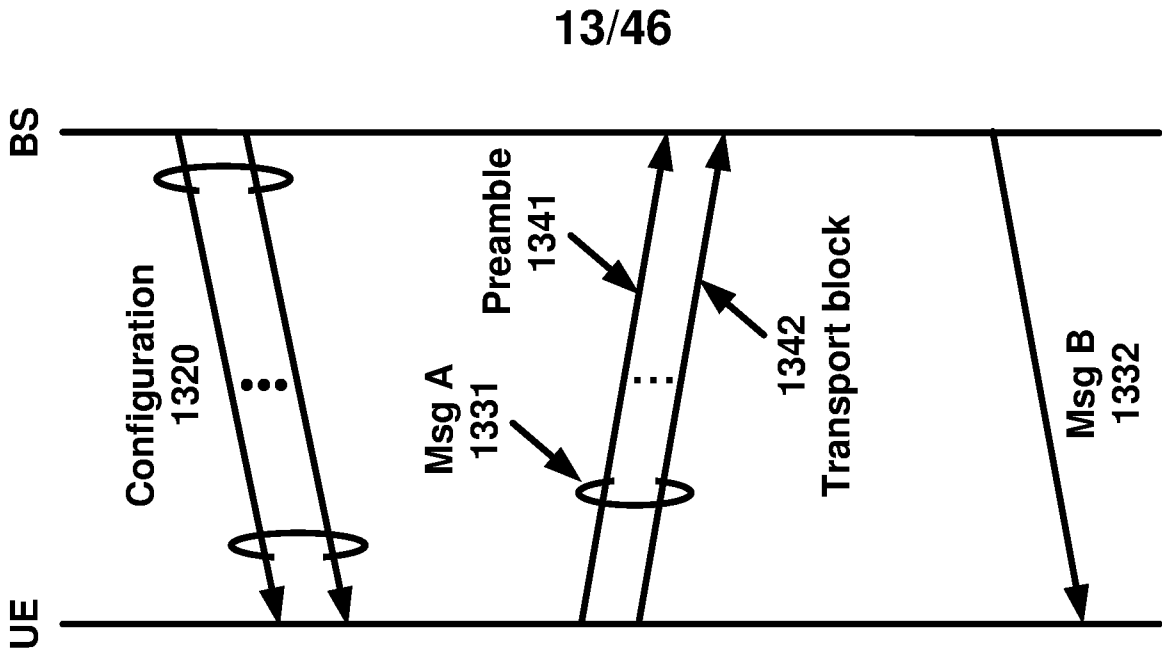

FIG. 13C

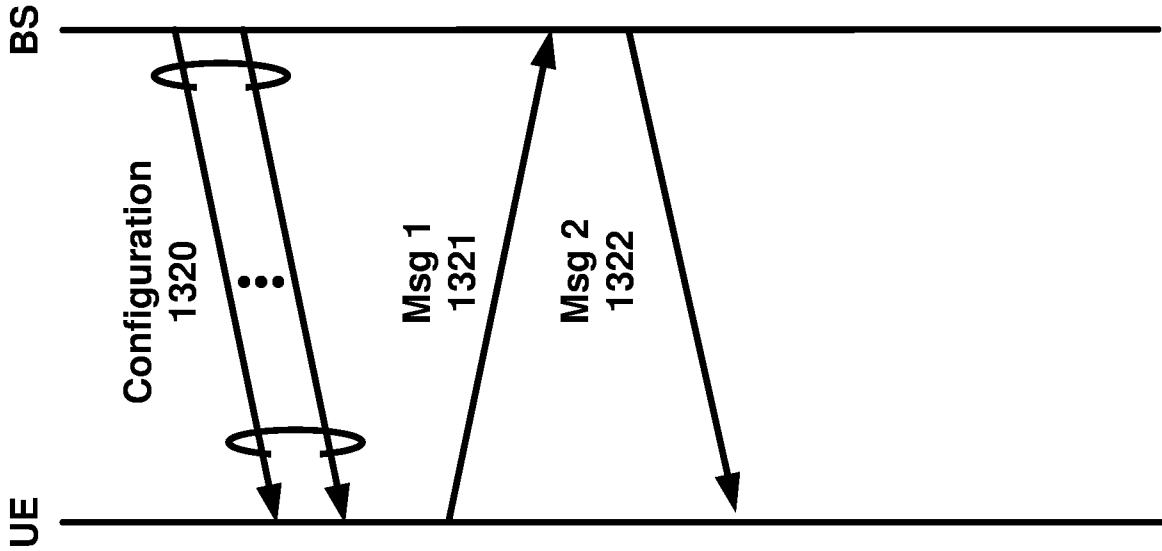

FIG. 13B

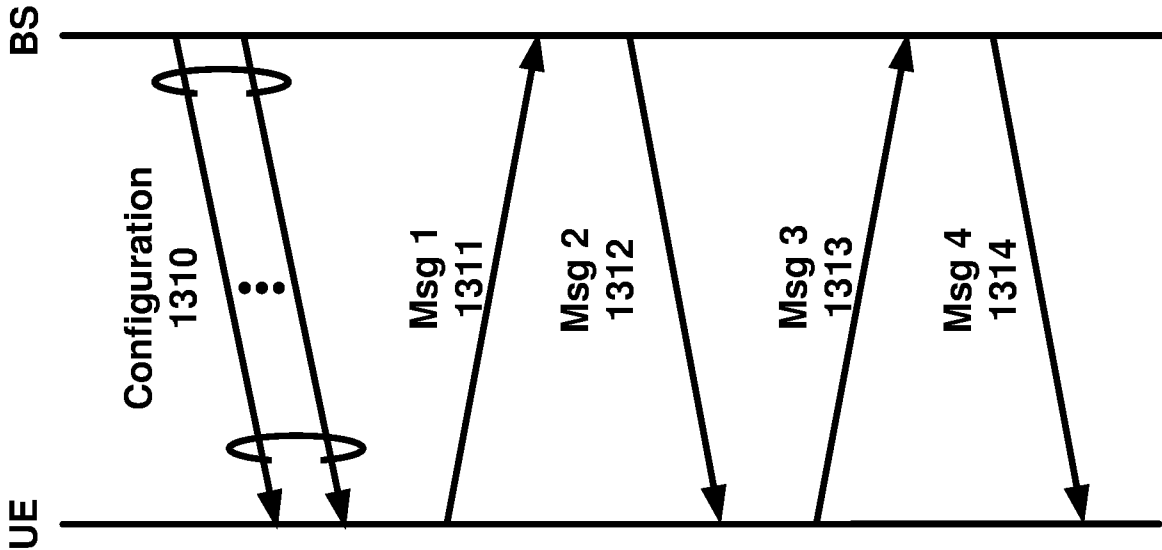

FIG. 13A

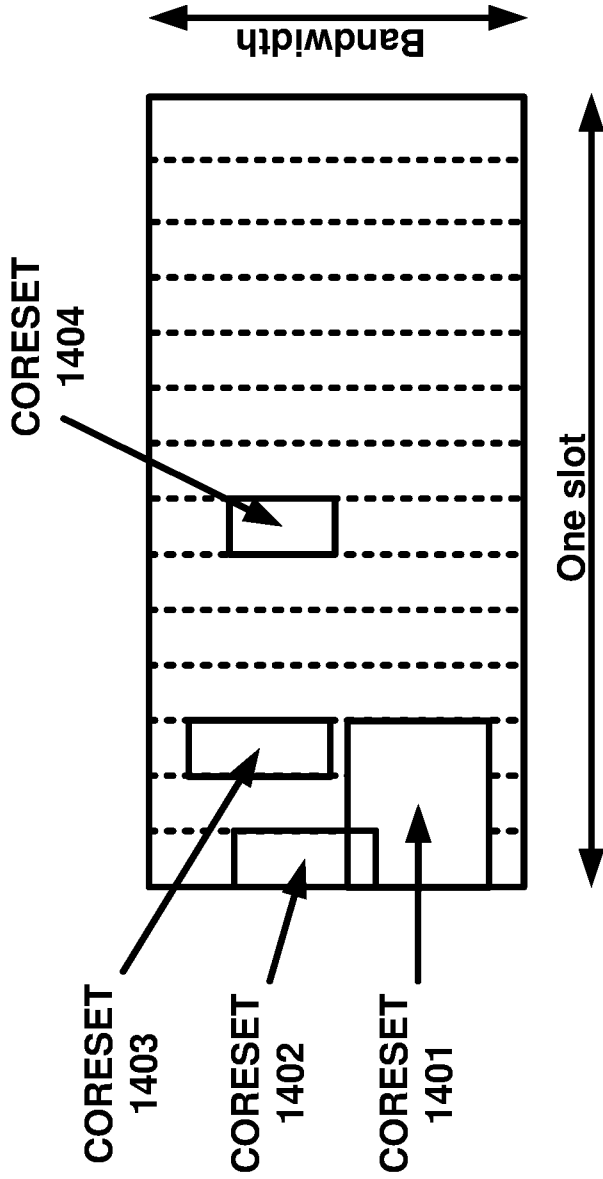

FIG. 14A

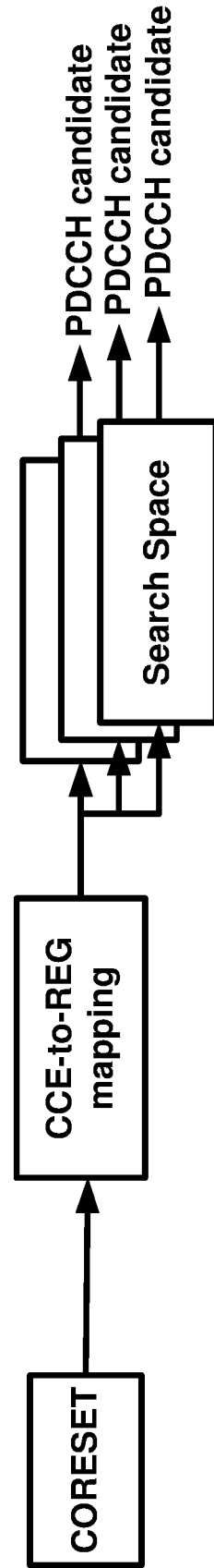

FIG. 14B

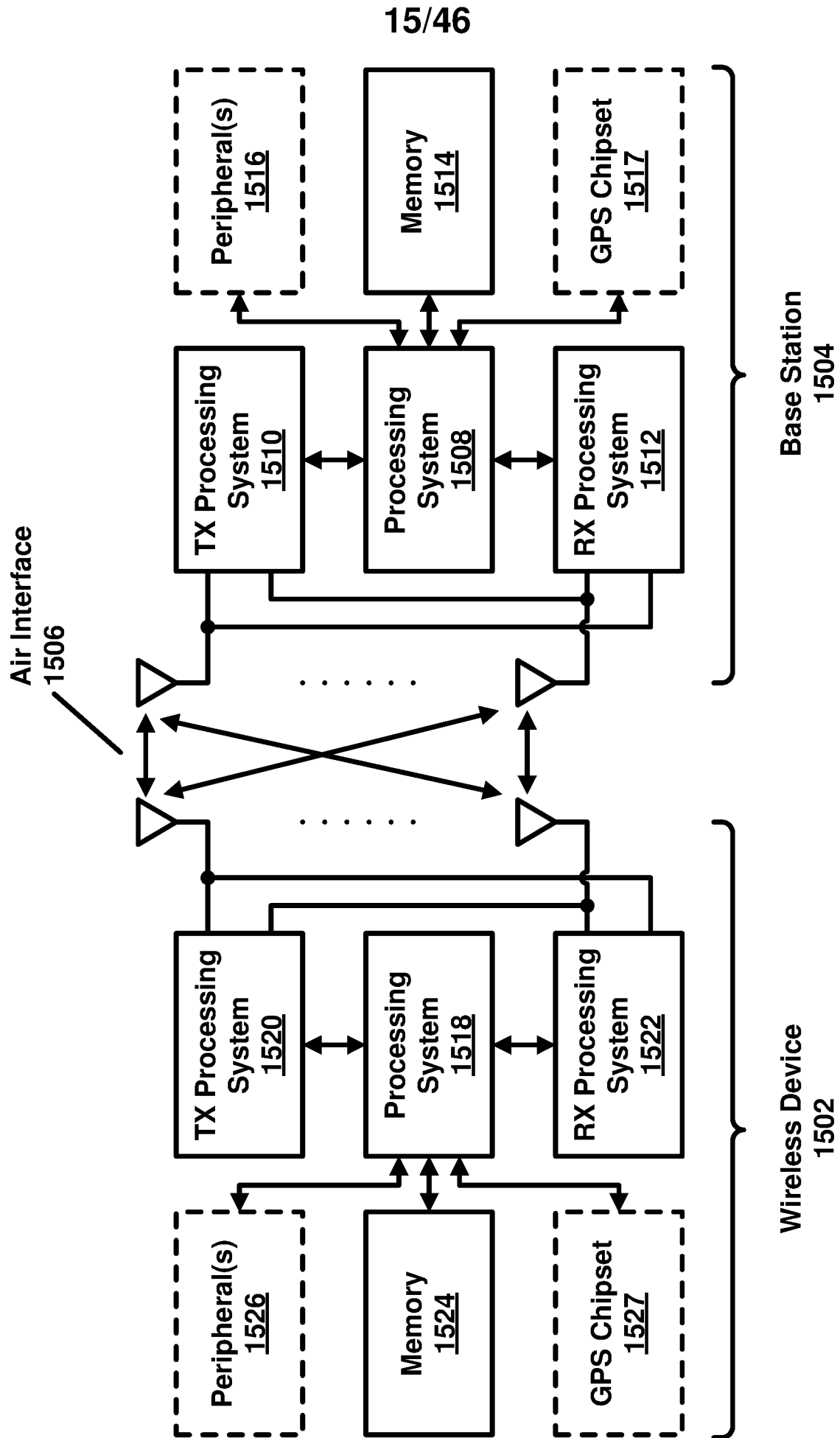

FIG. 15

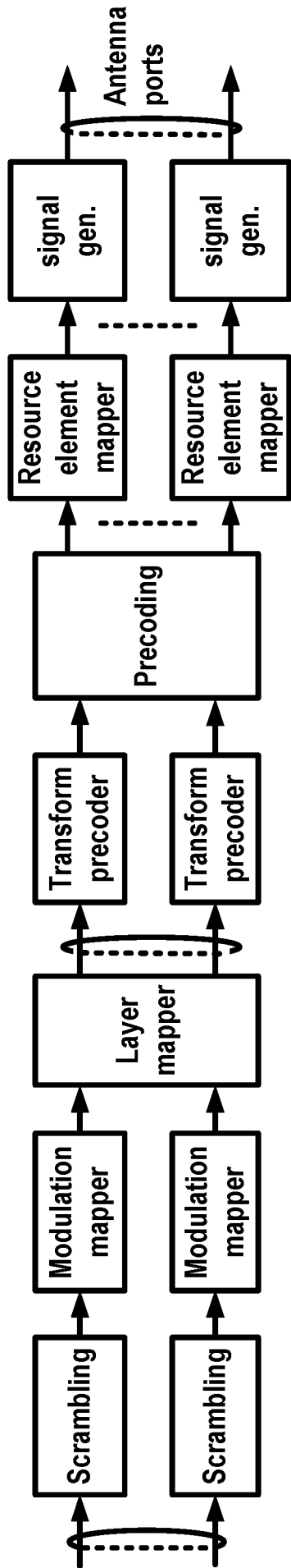

FIG. 16A

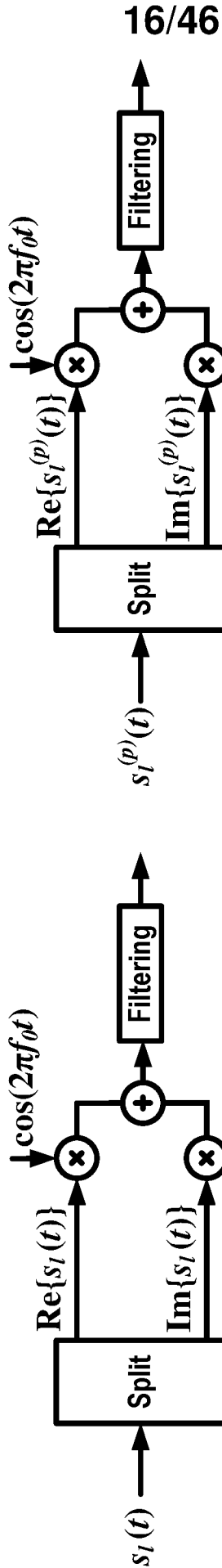

FIG. 16B

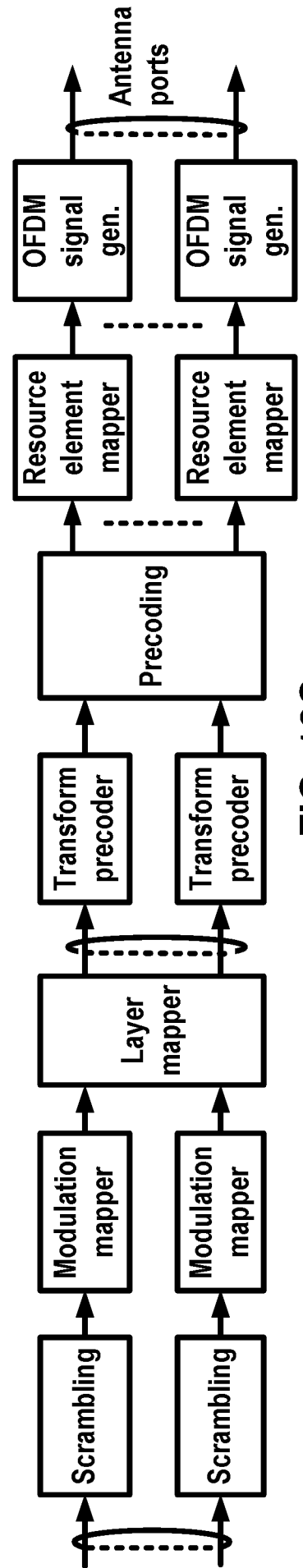

FIG. 16C

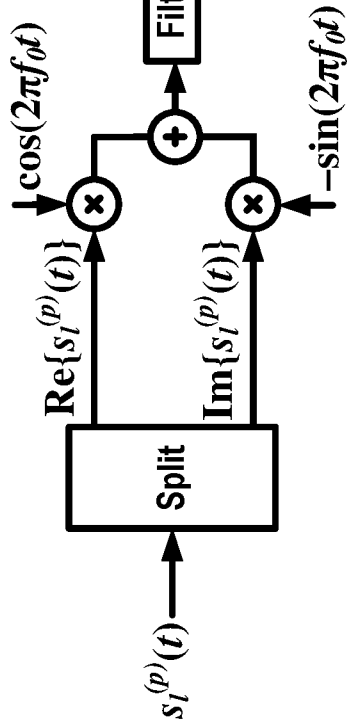

FIG. 16D

17/46

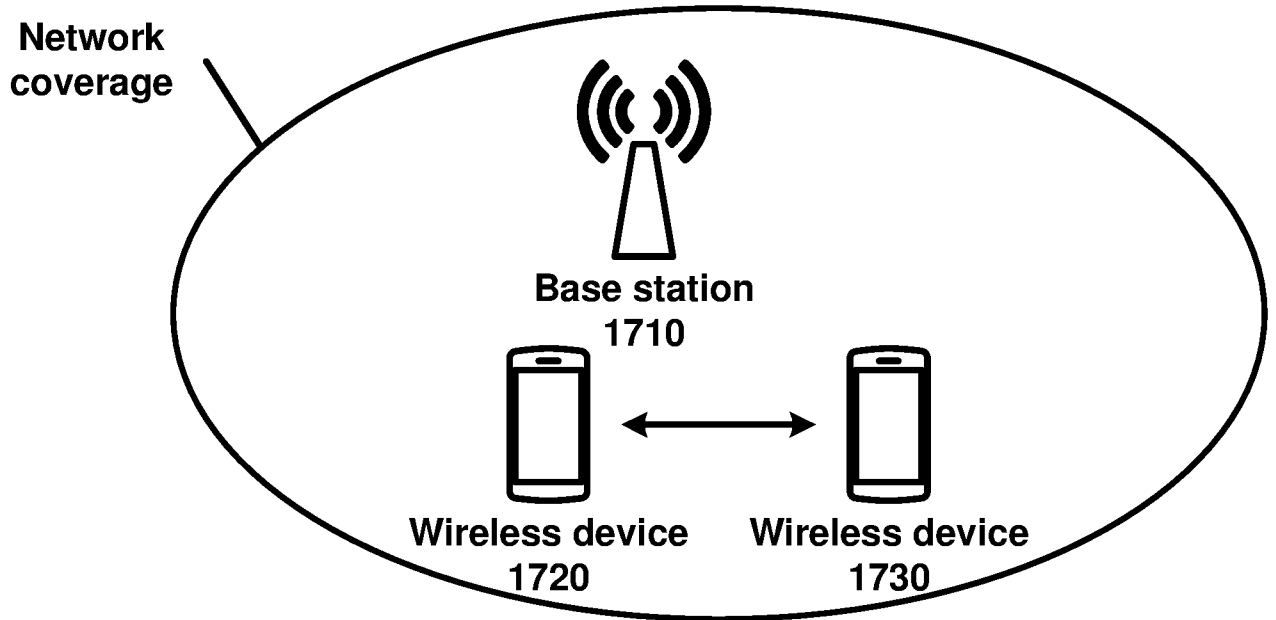

FIG. 17A

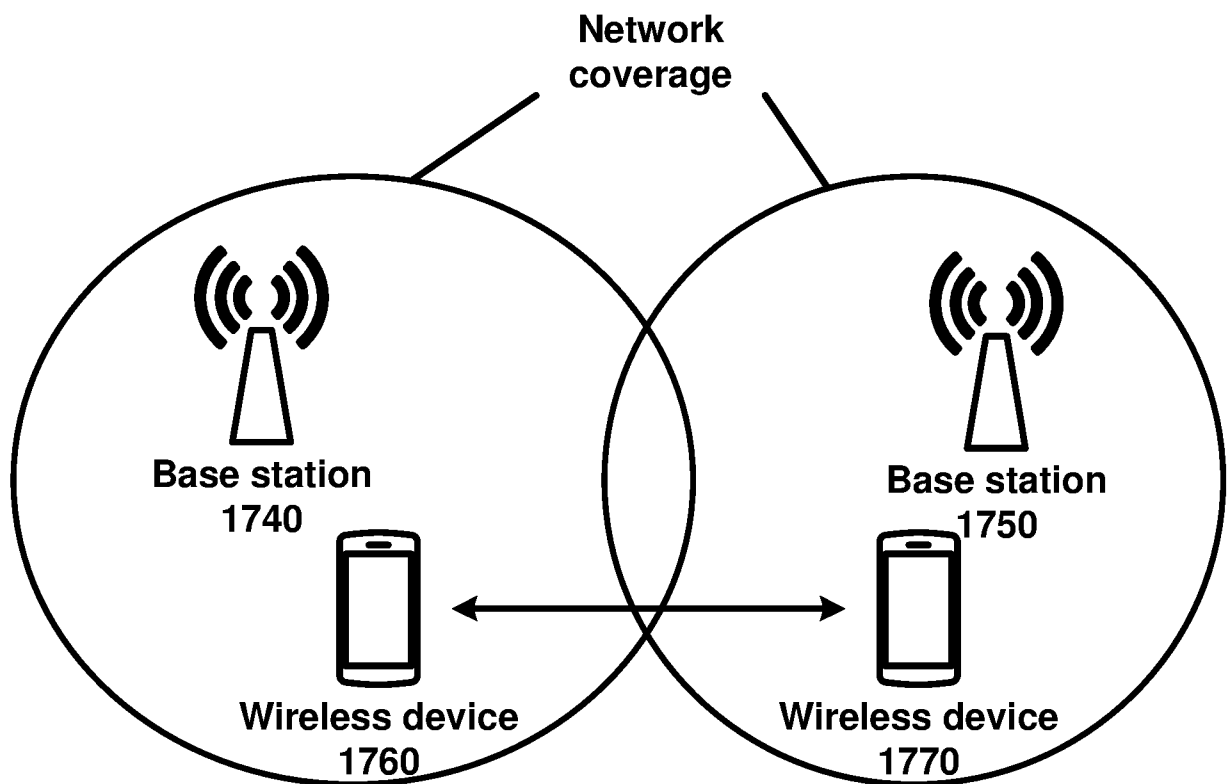

FIG. 17B

18/46

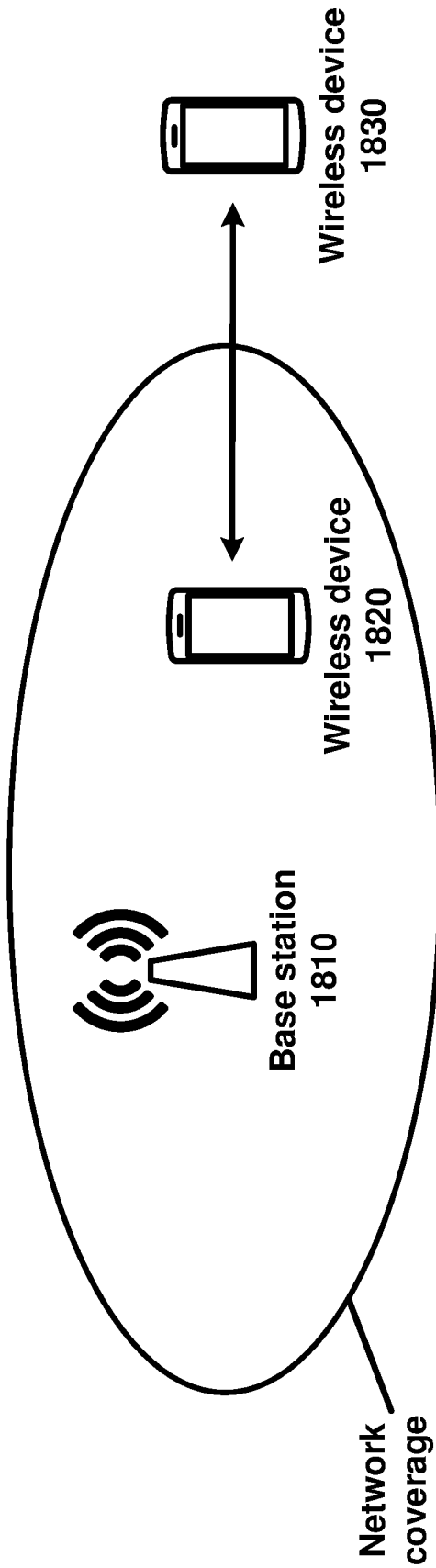

FIG. 18

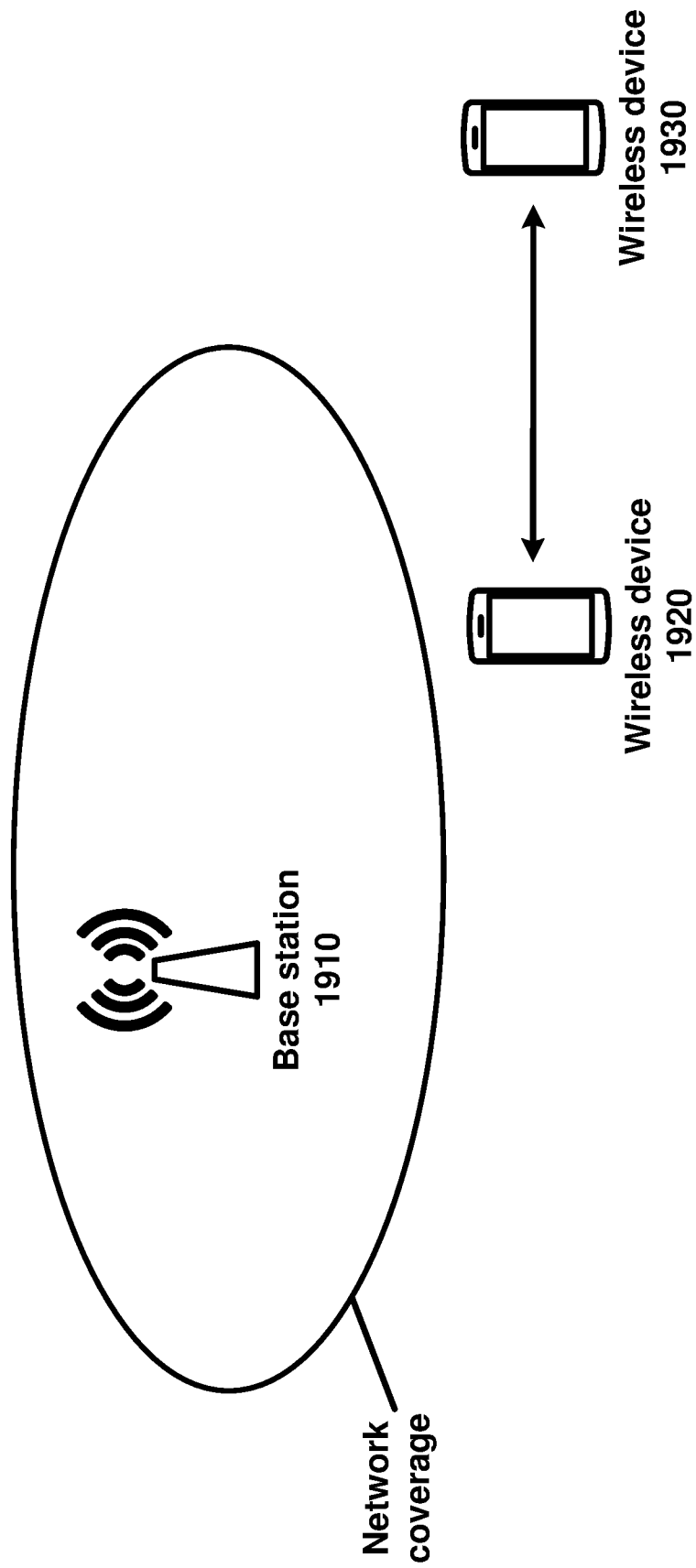

FIG. 19

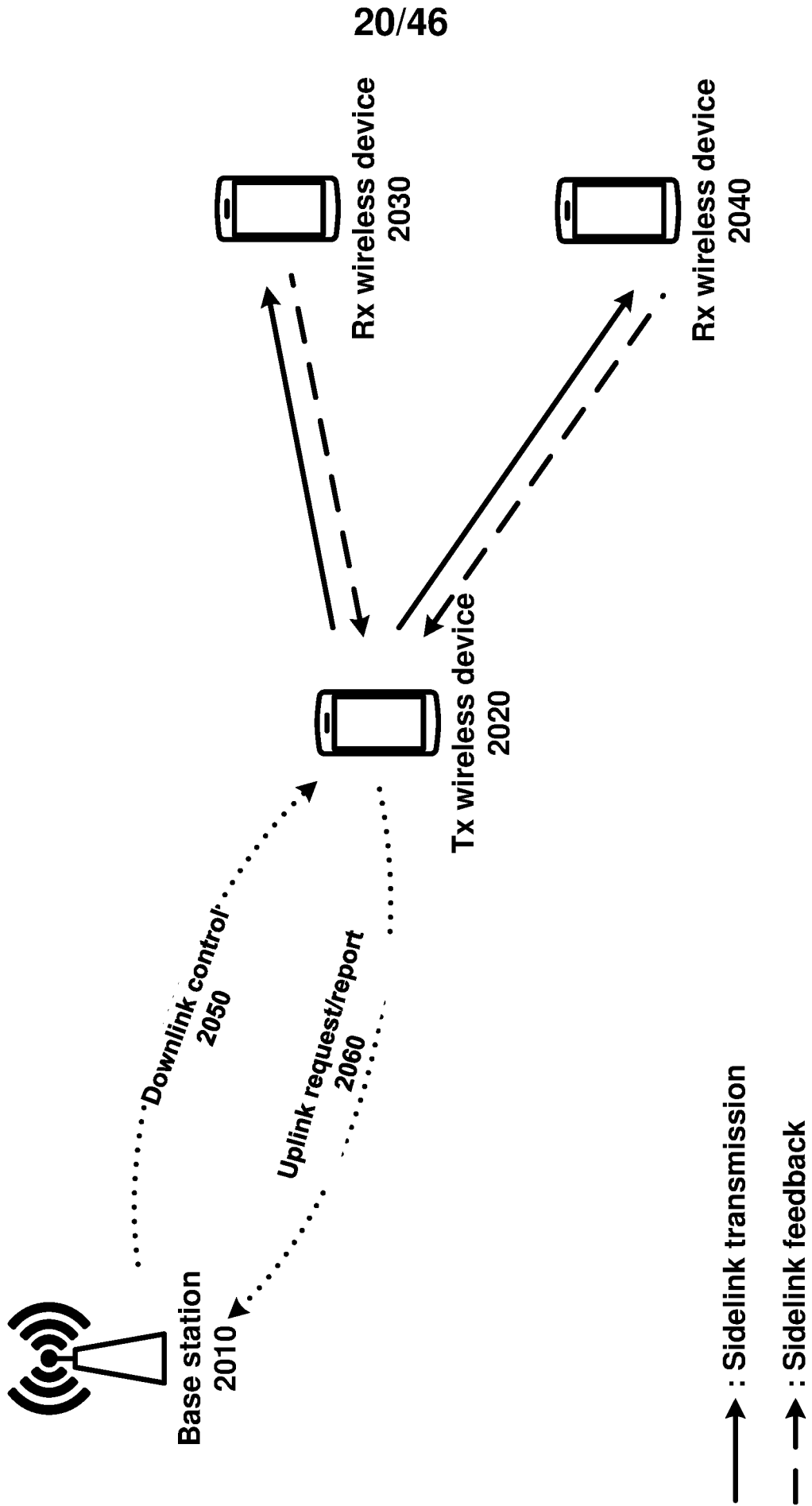

FIG. 20

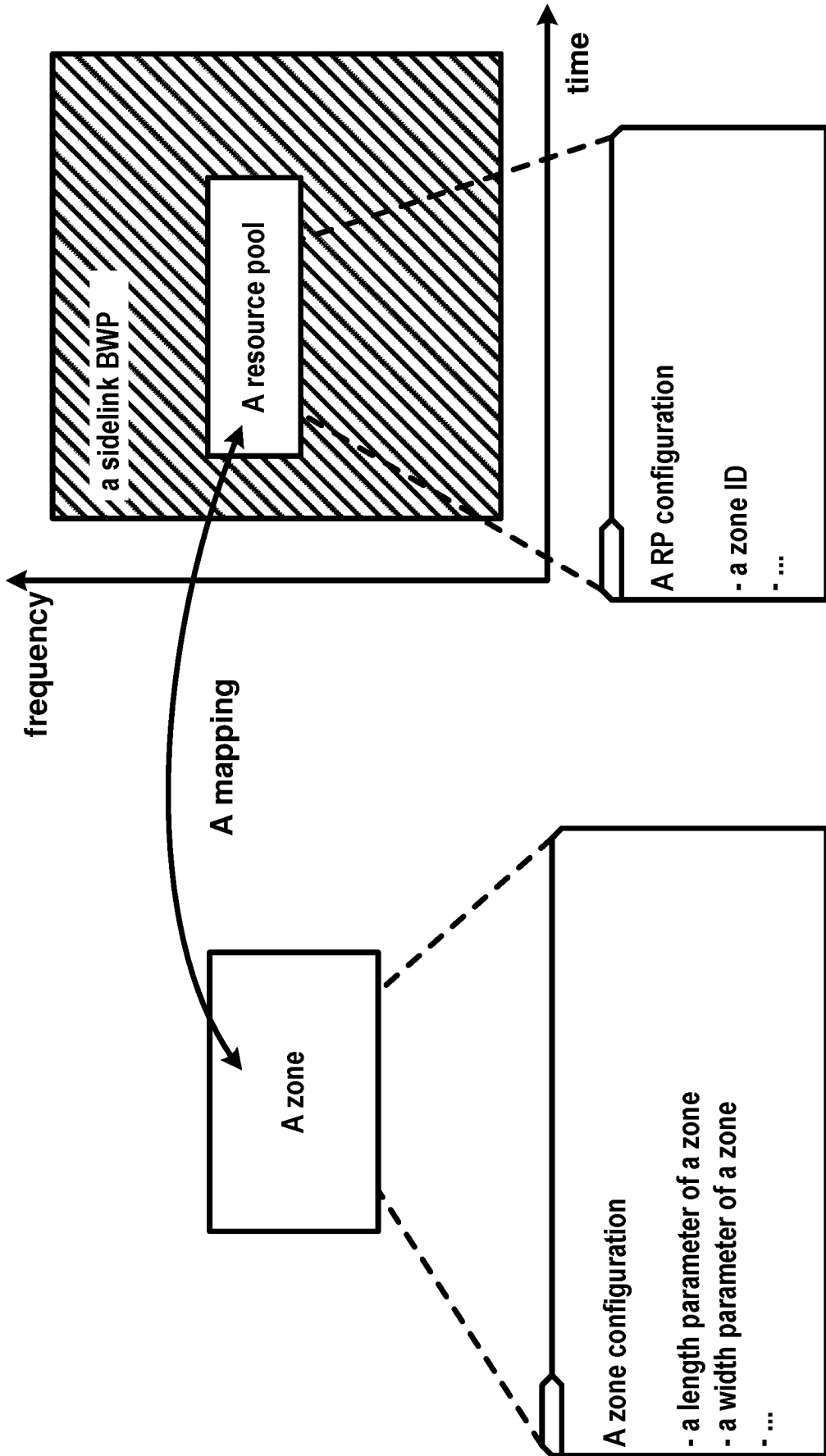

FIG. 21

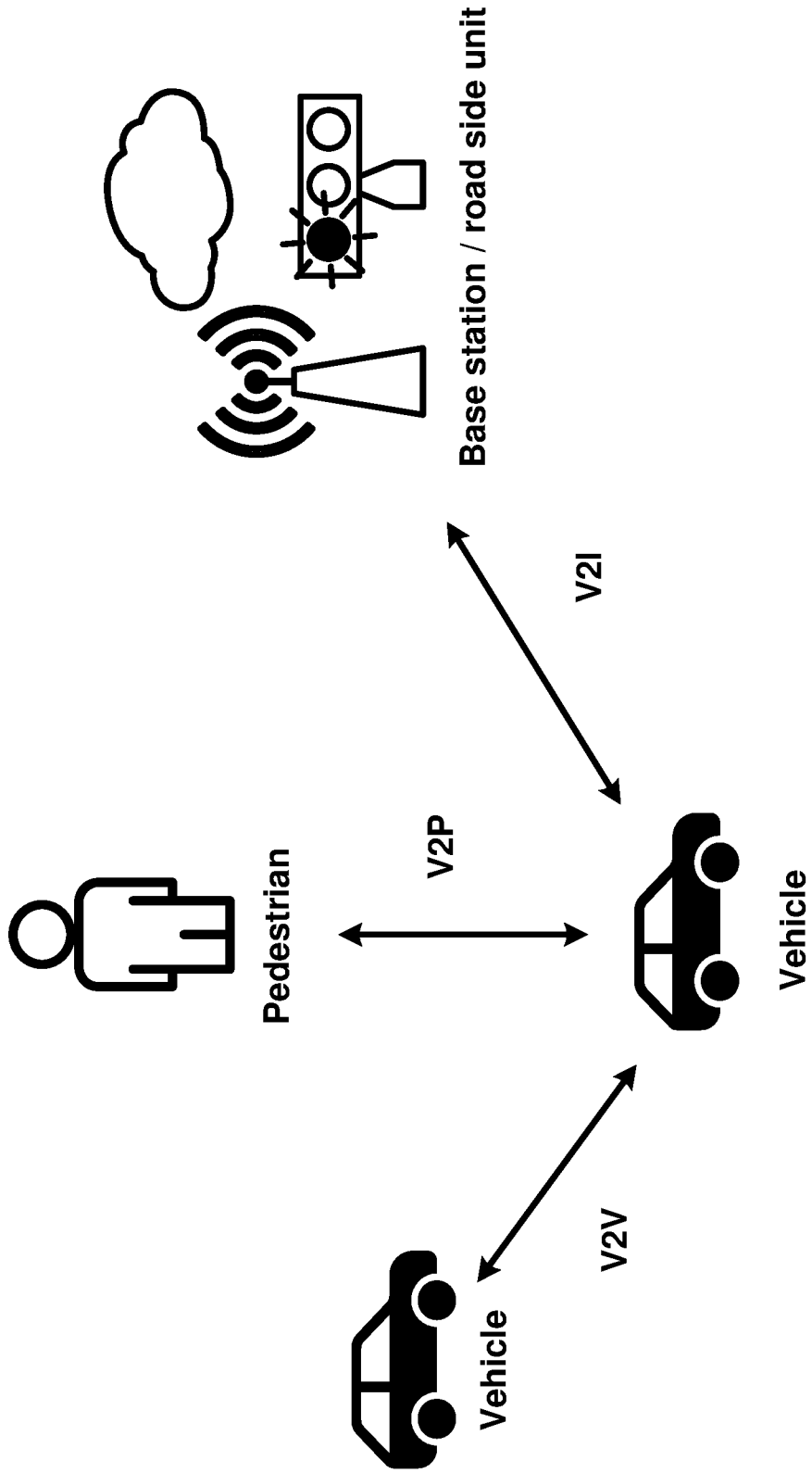

FIG. 22

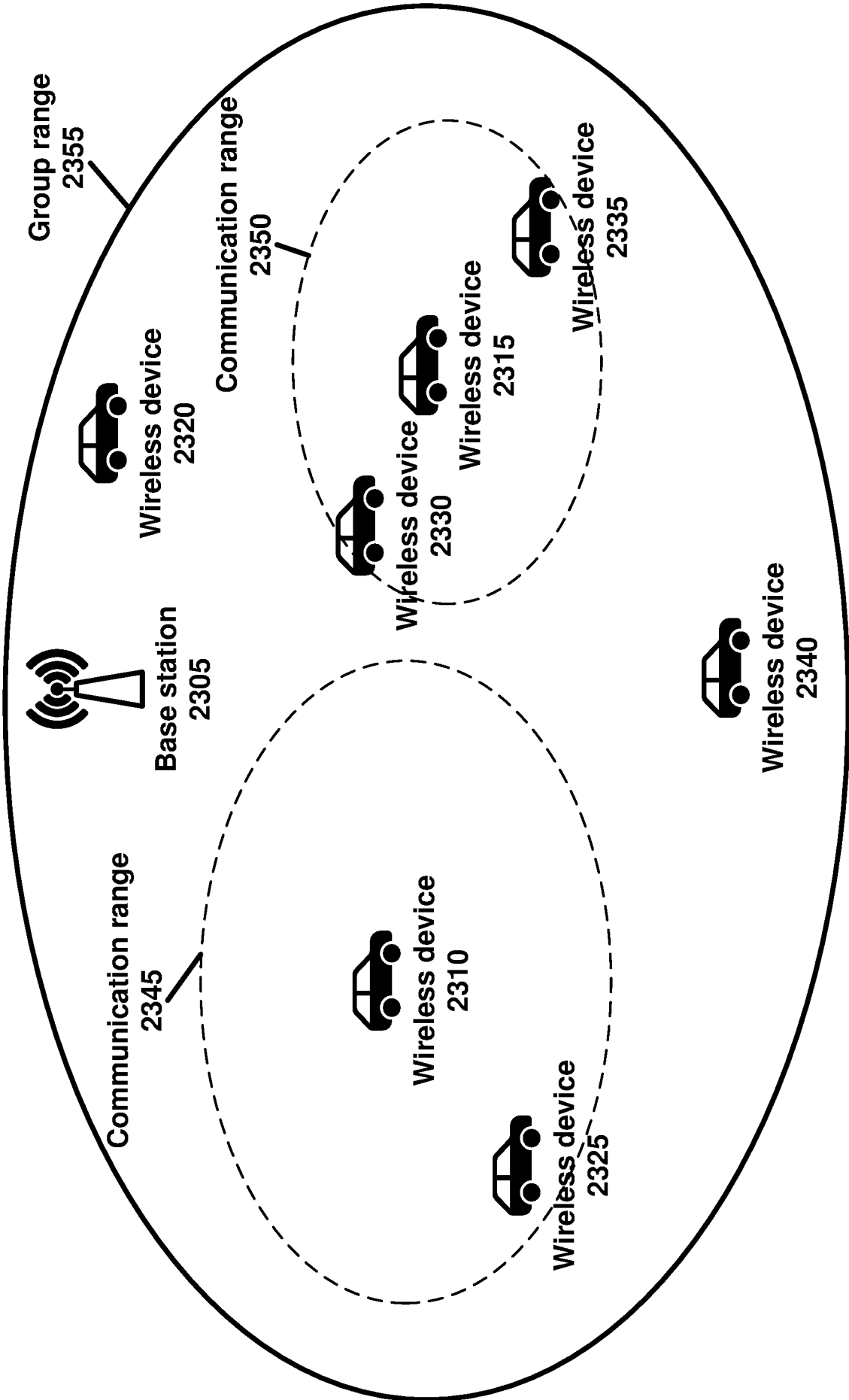

FIG. 23

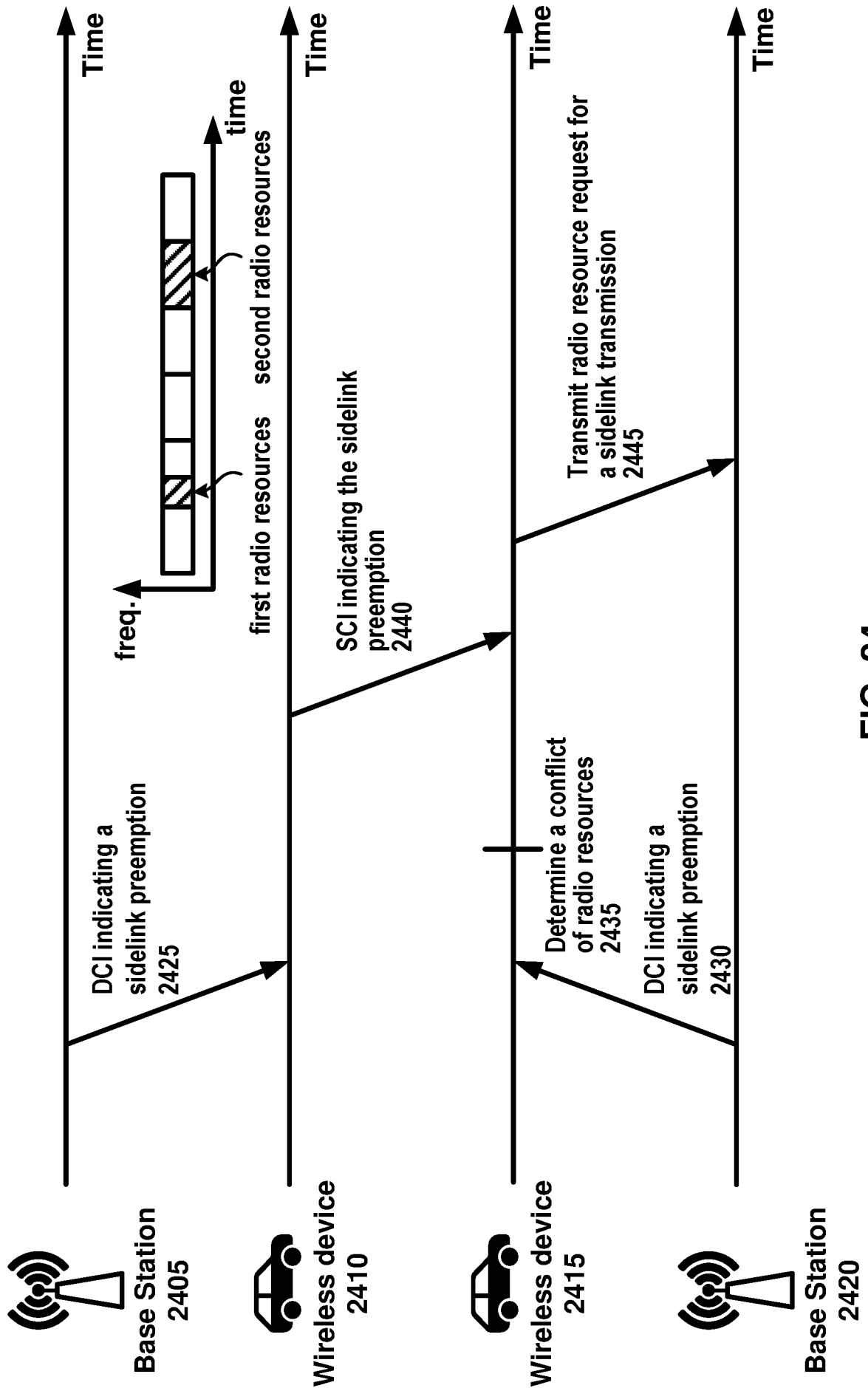

FIG. 24

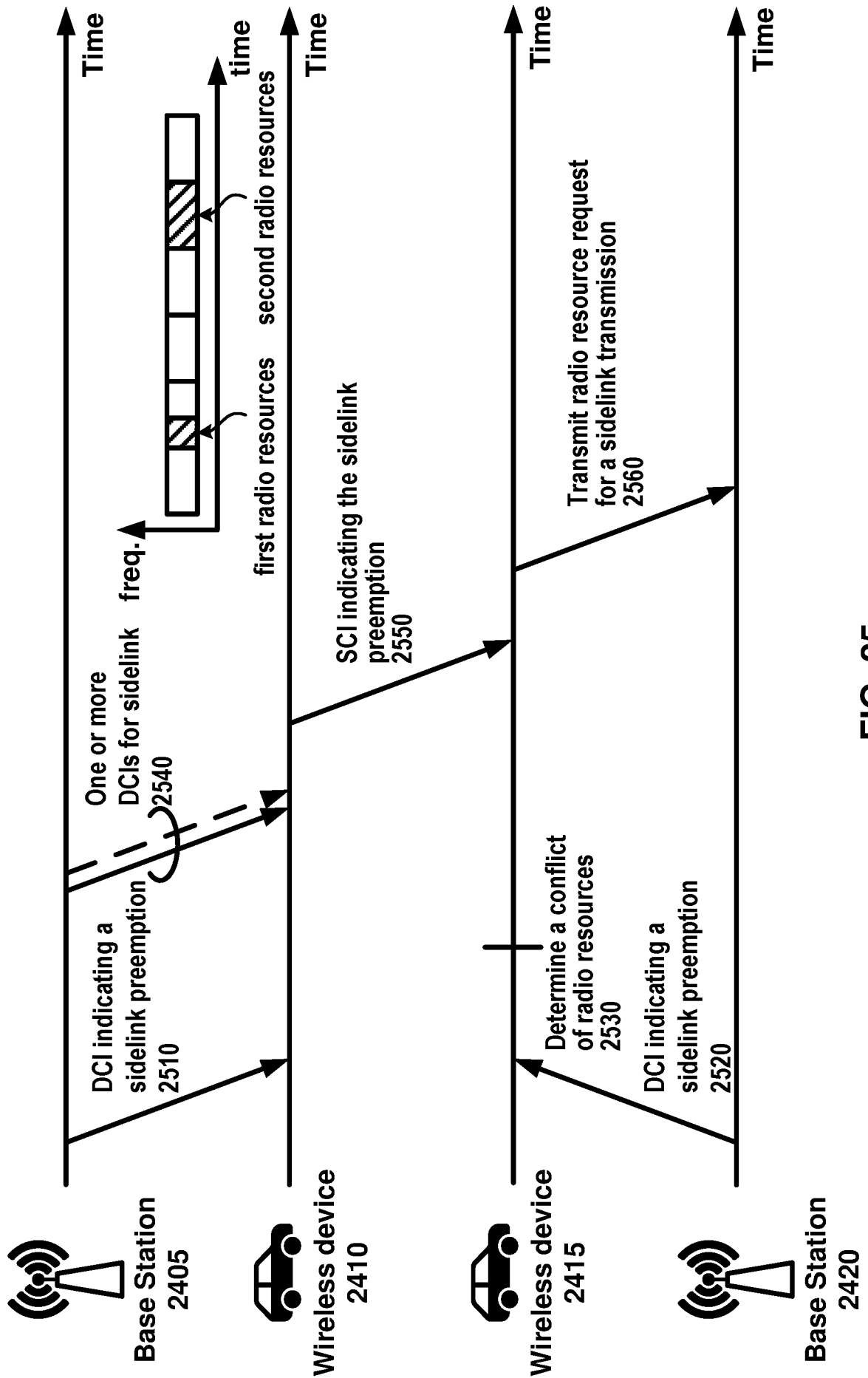

FIG. 25

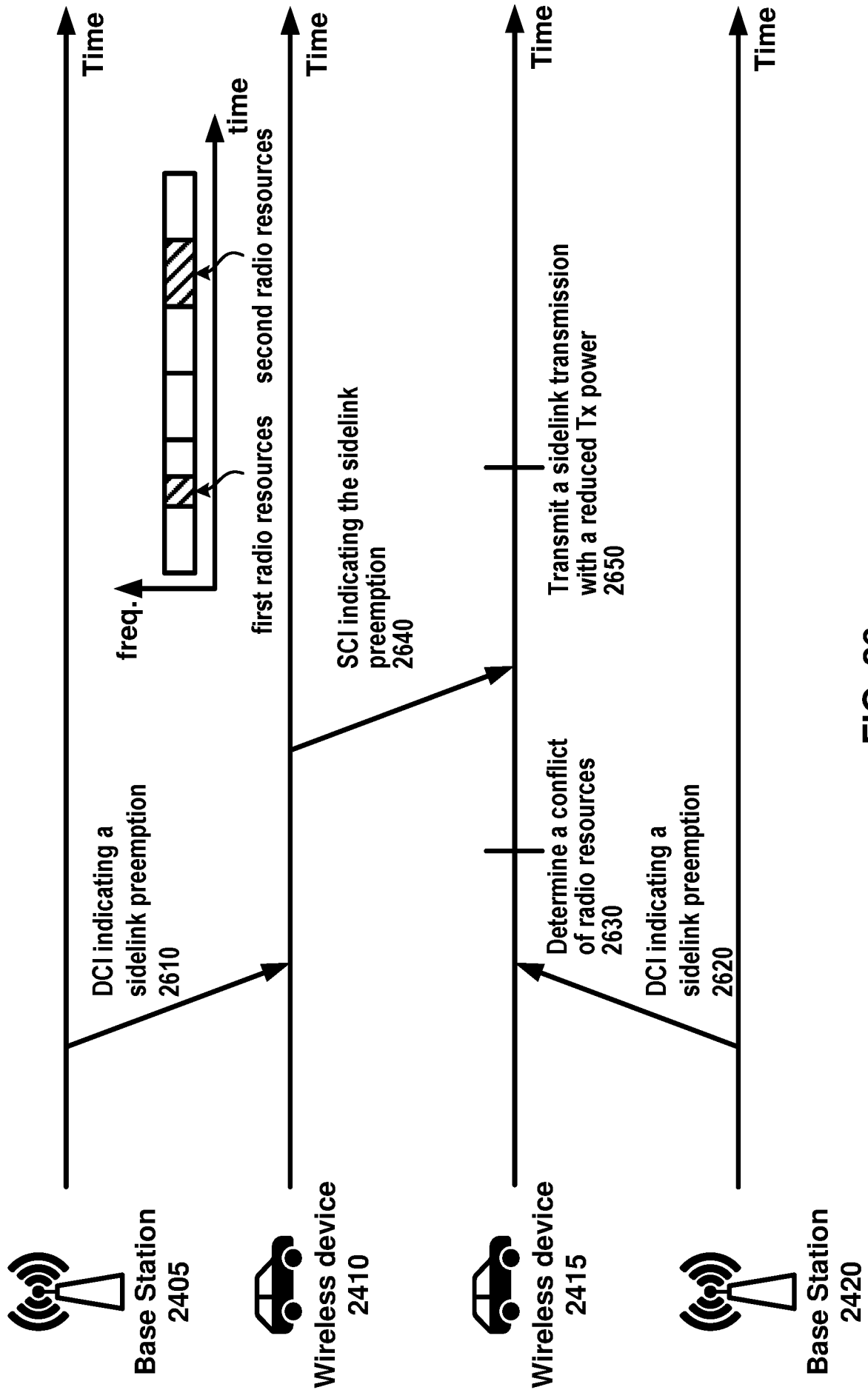

FIG. 26

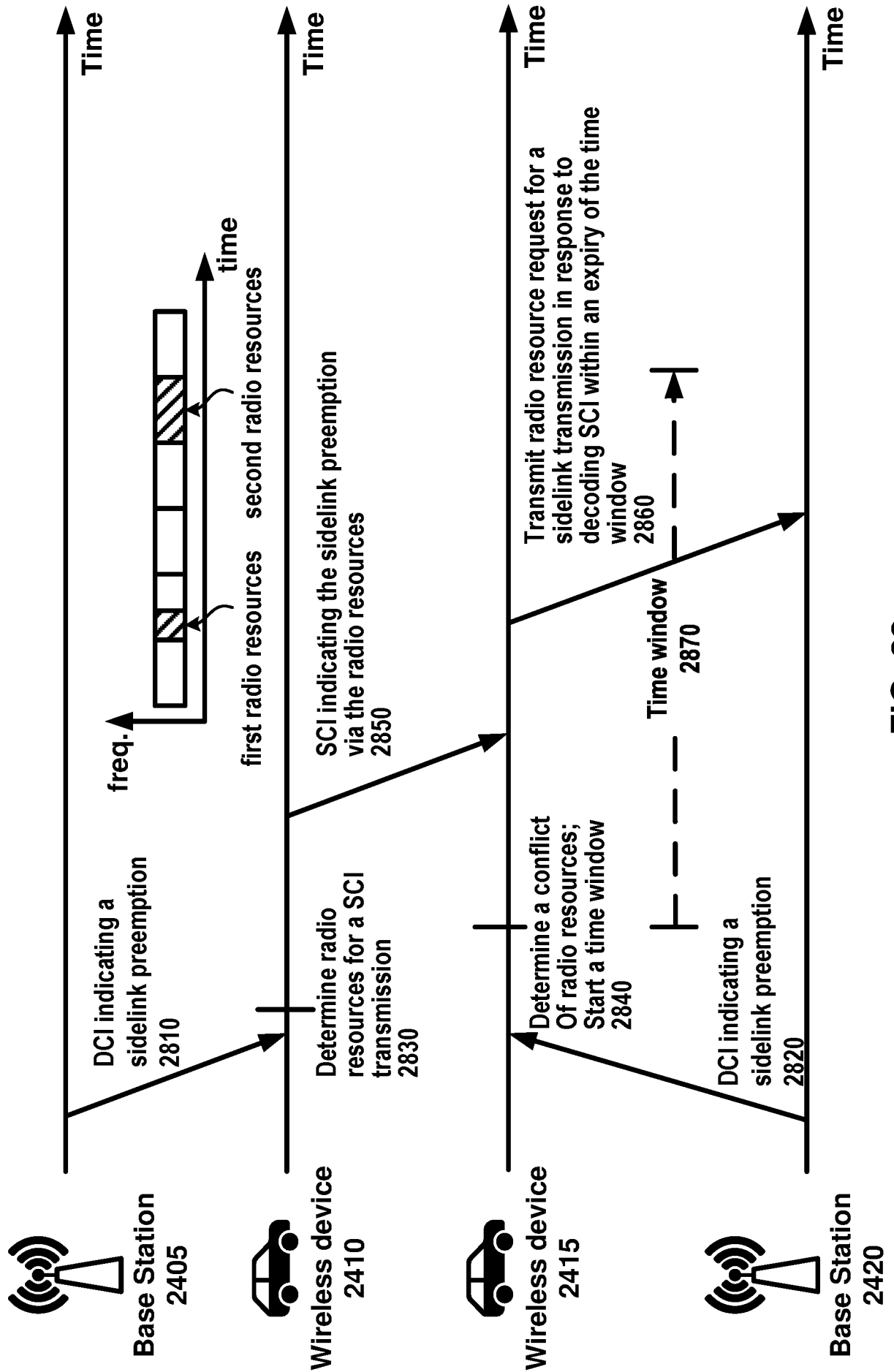

FIG. 28

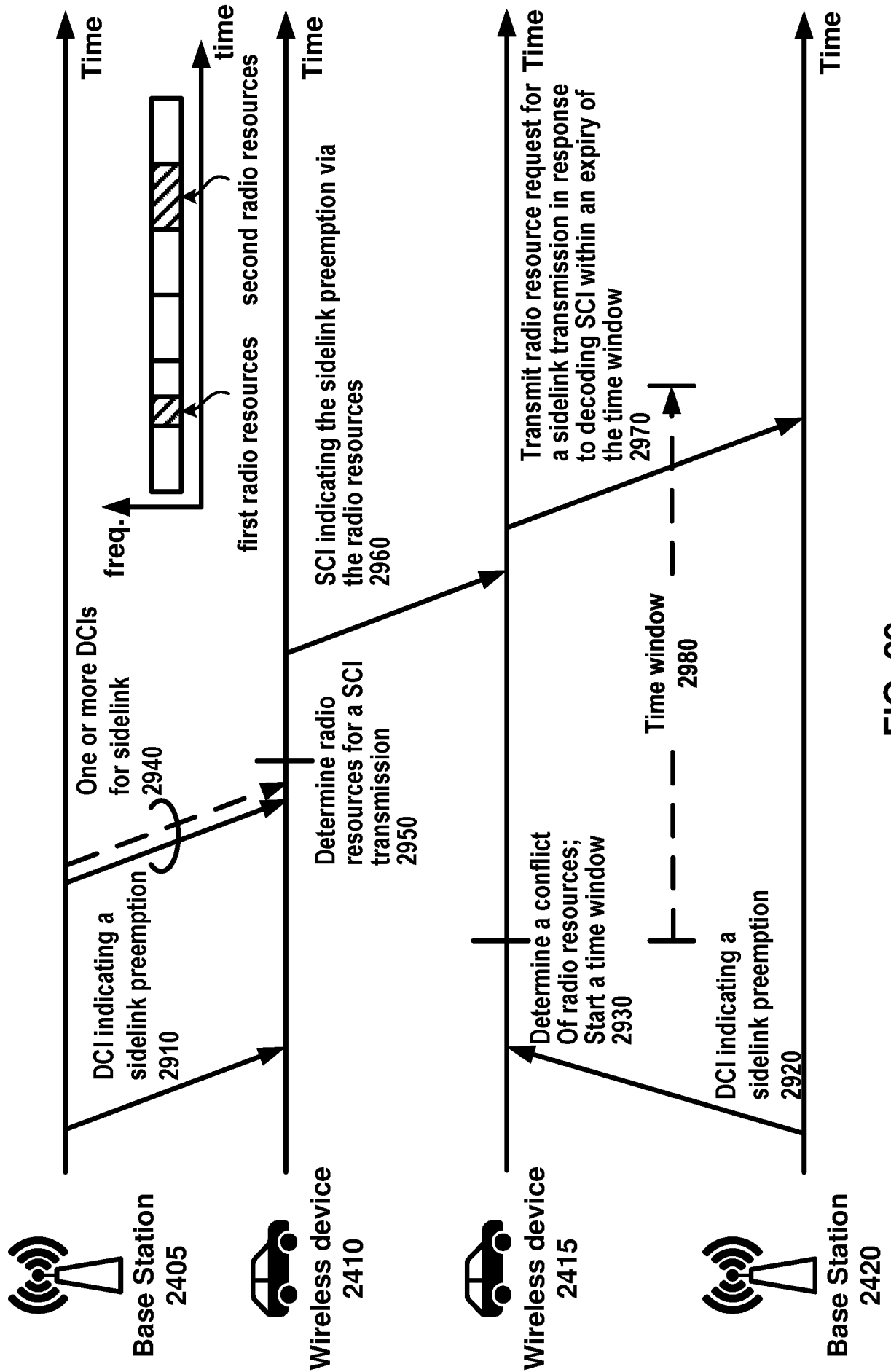

FIG. 29

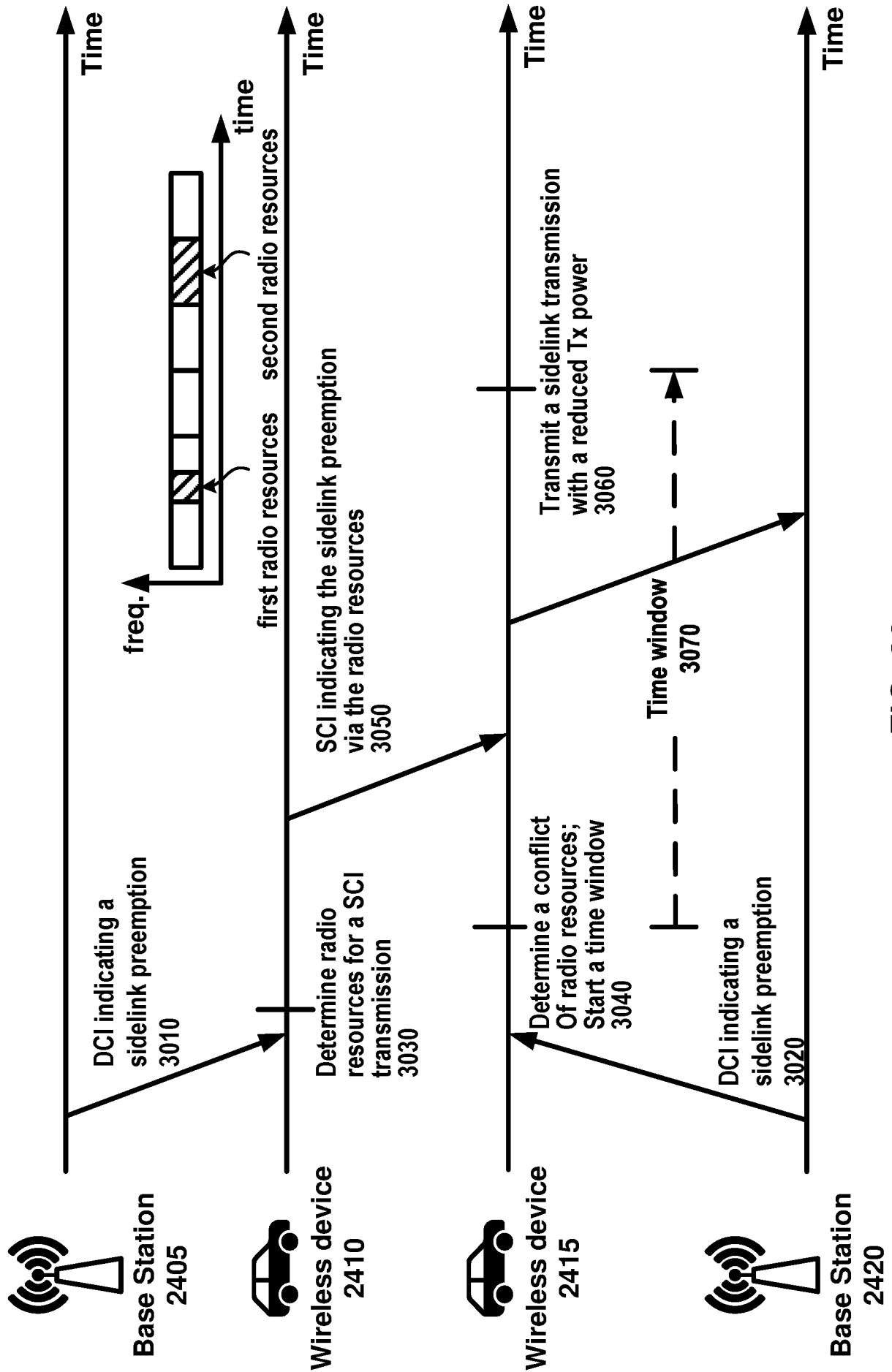

FIG. 30

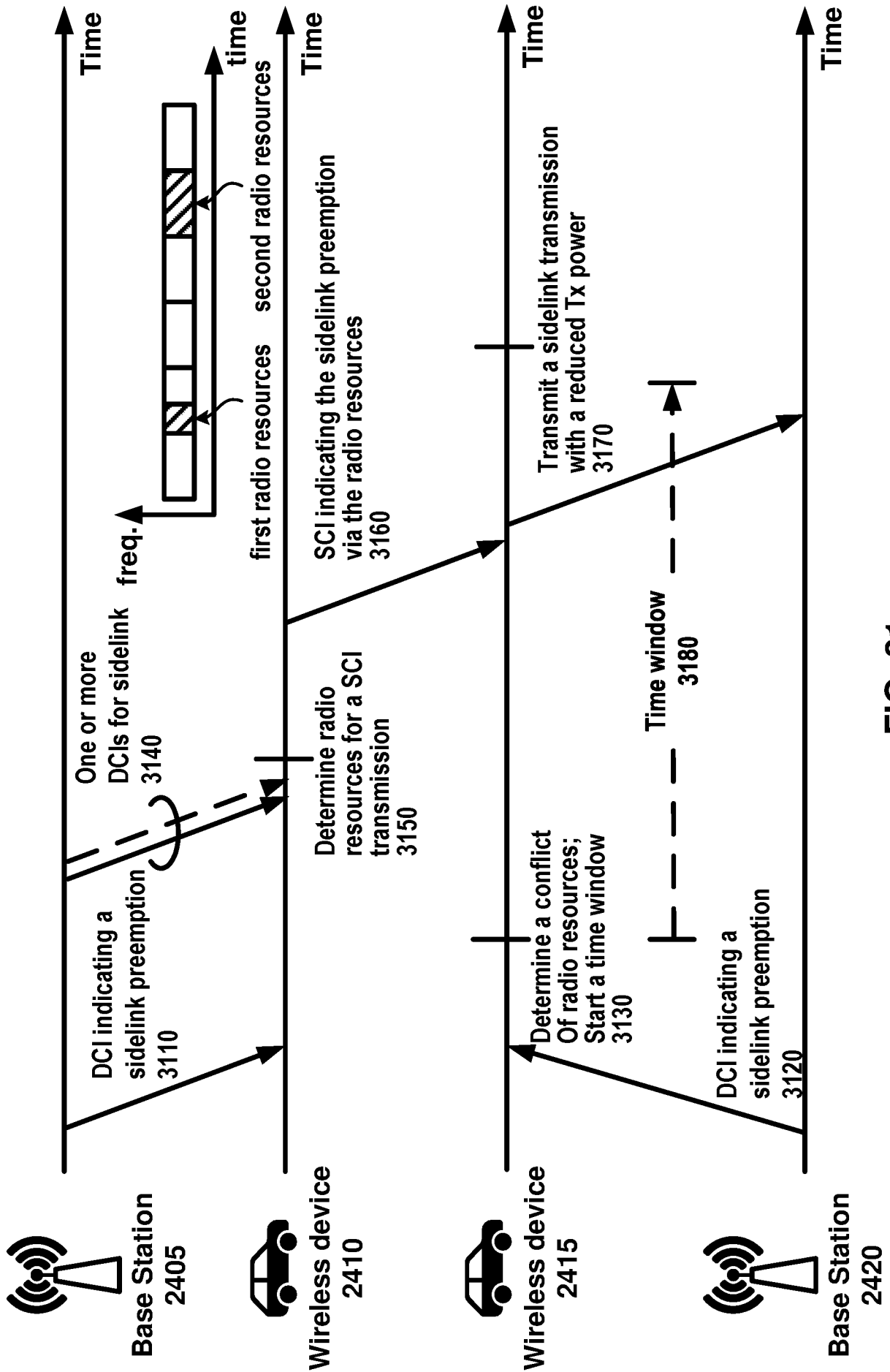

FIG. 31

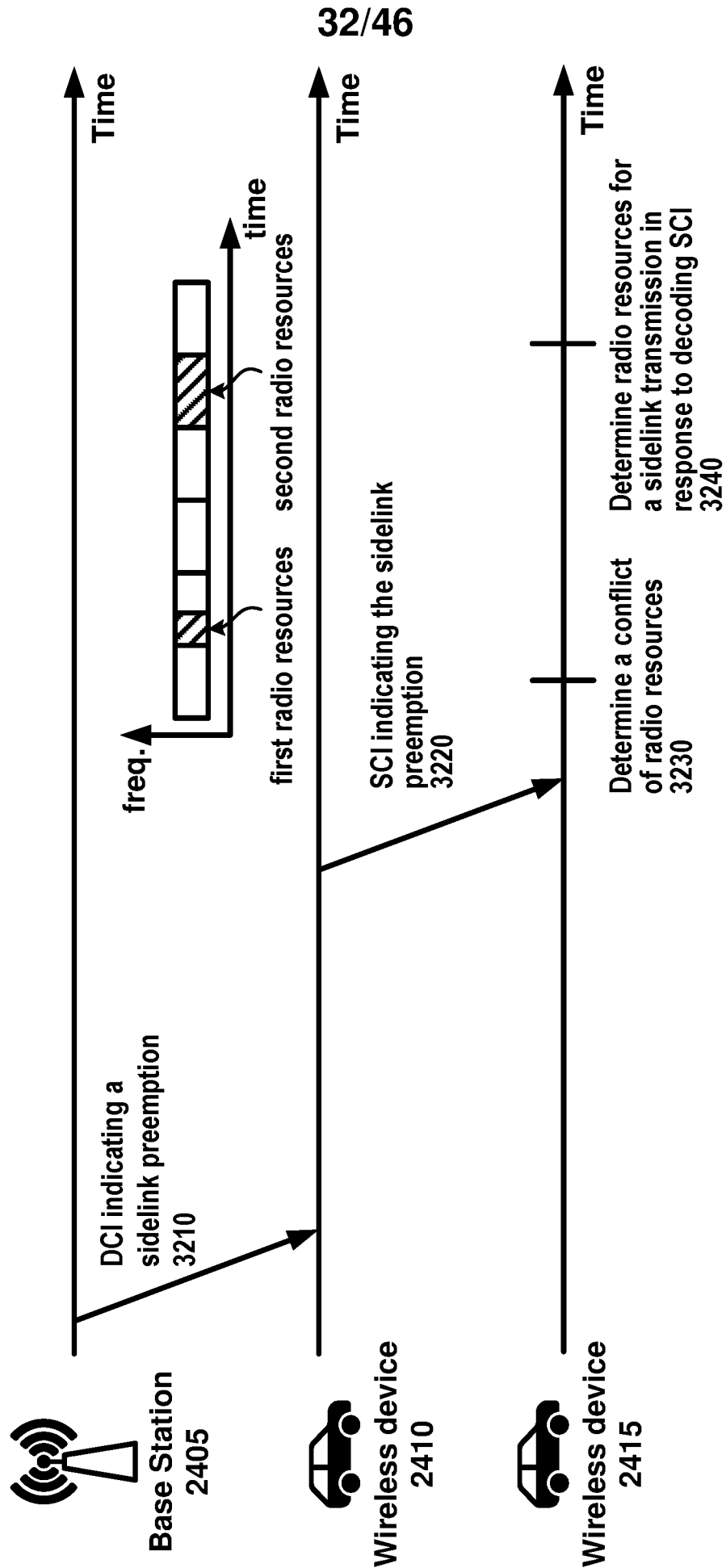

FIG. 32

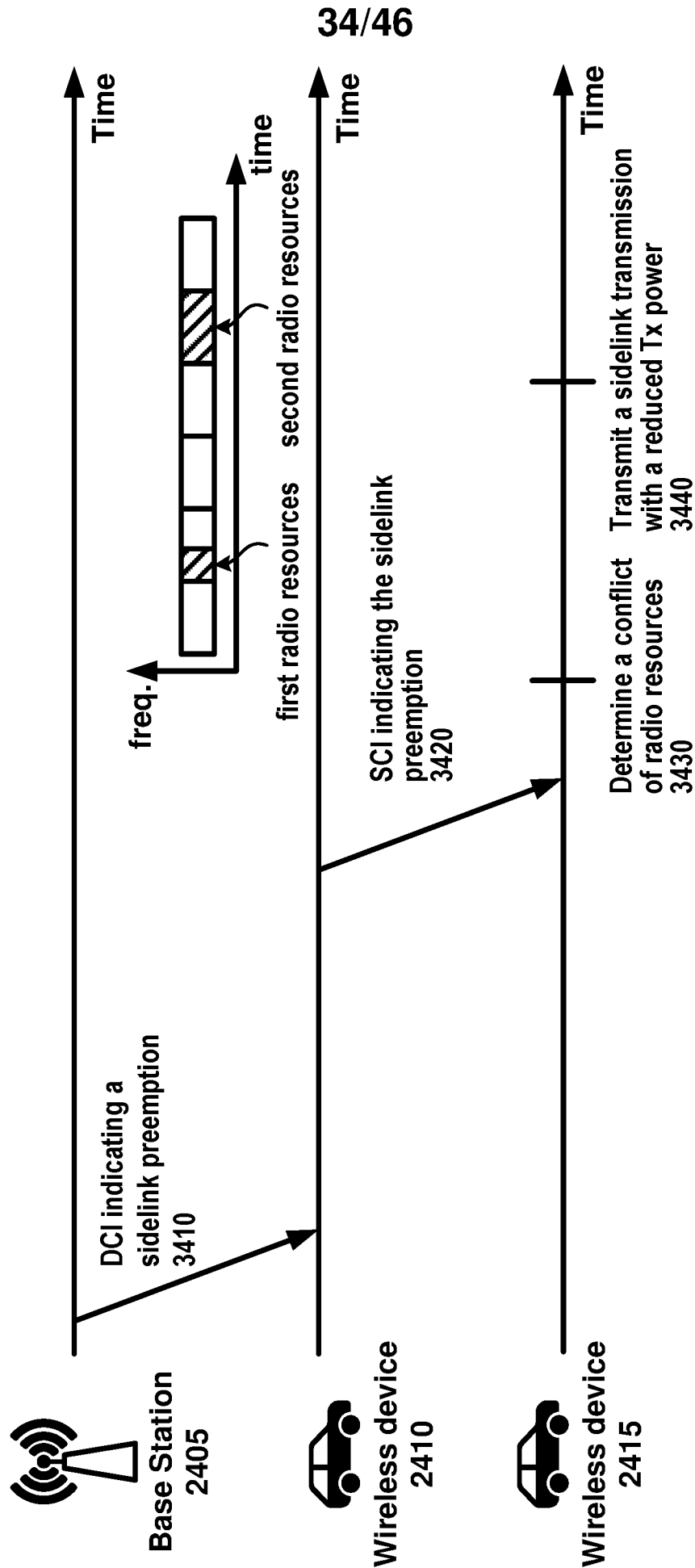

FIG. 34

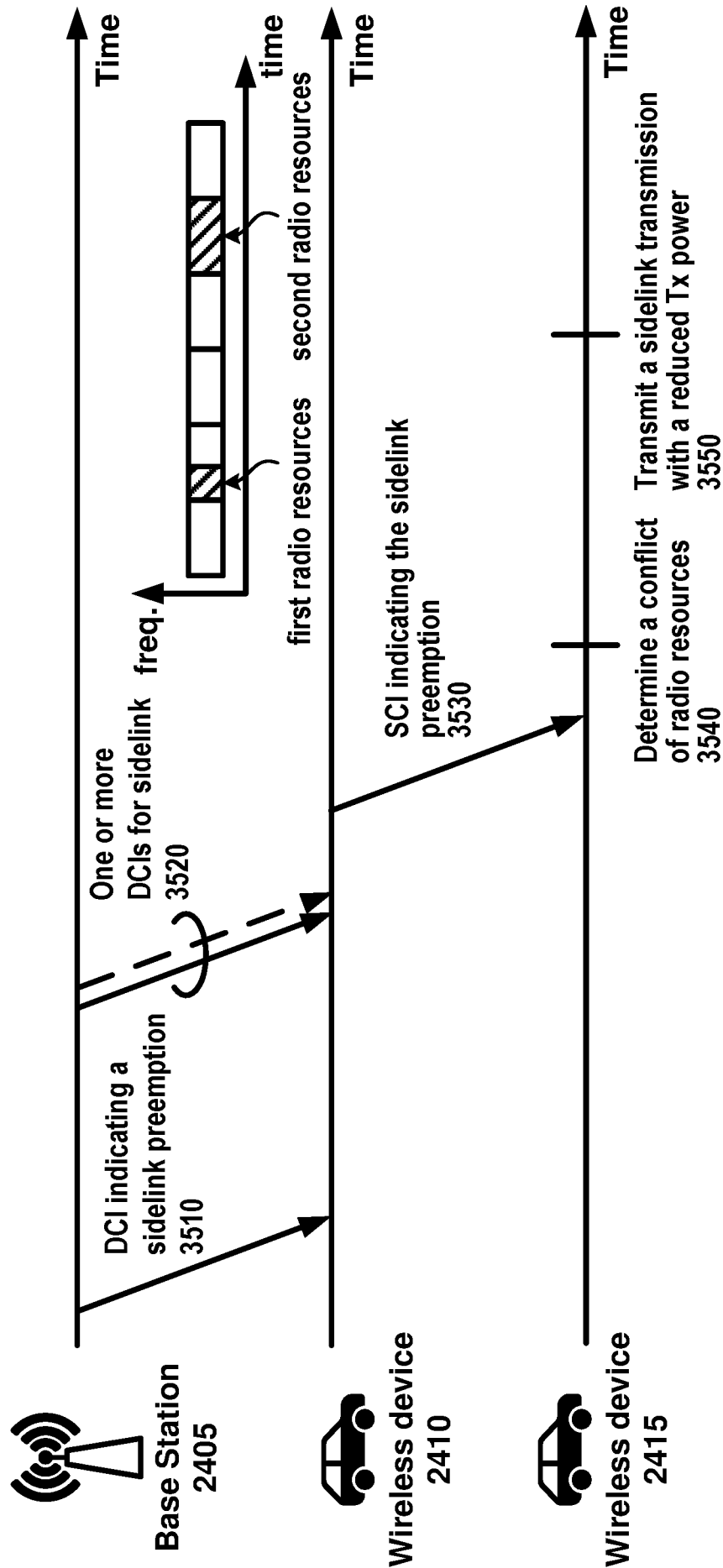

FIG. 35

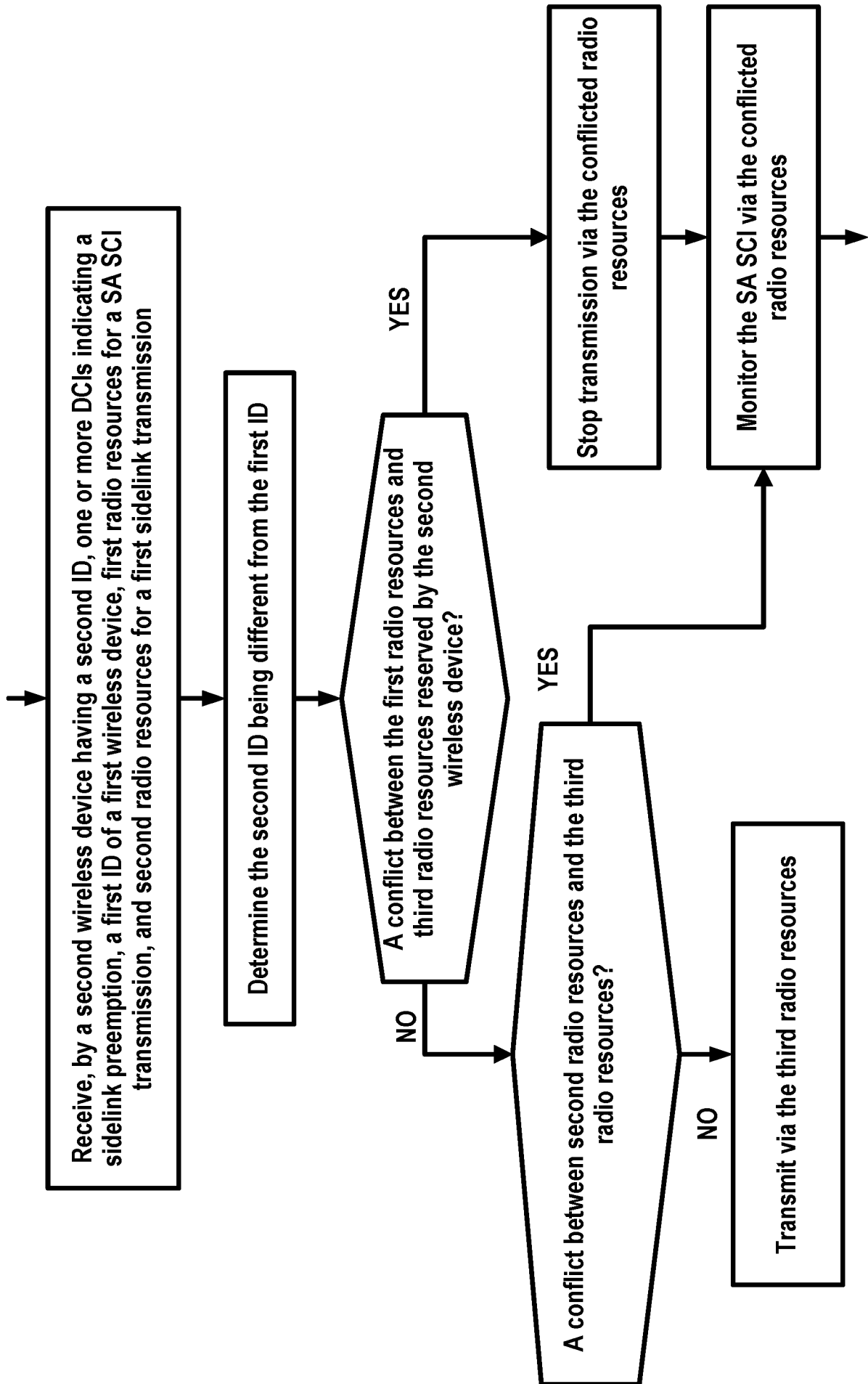

FIG. 36

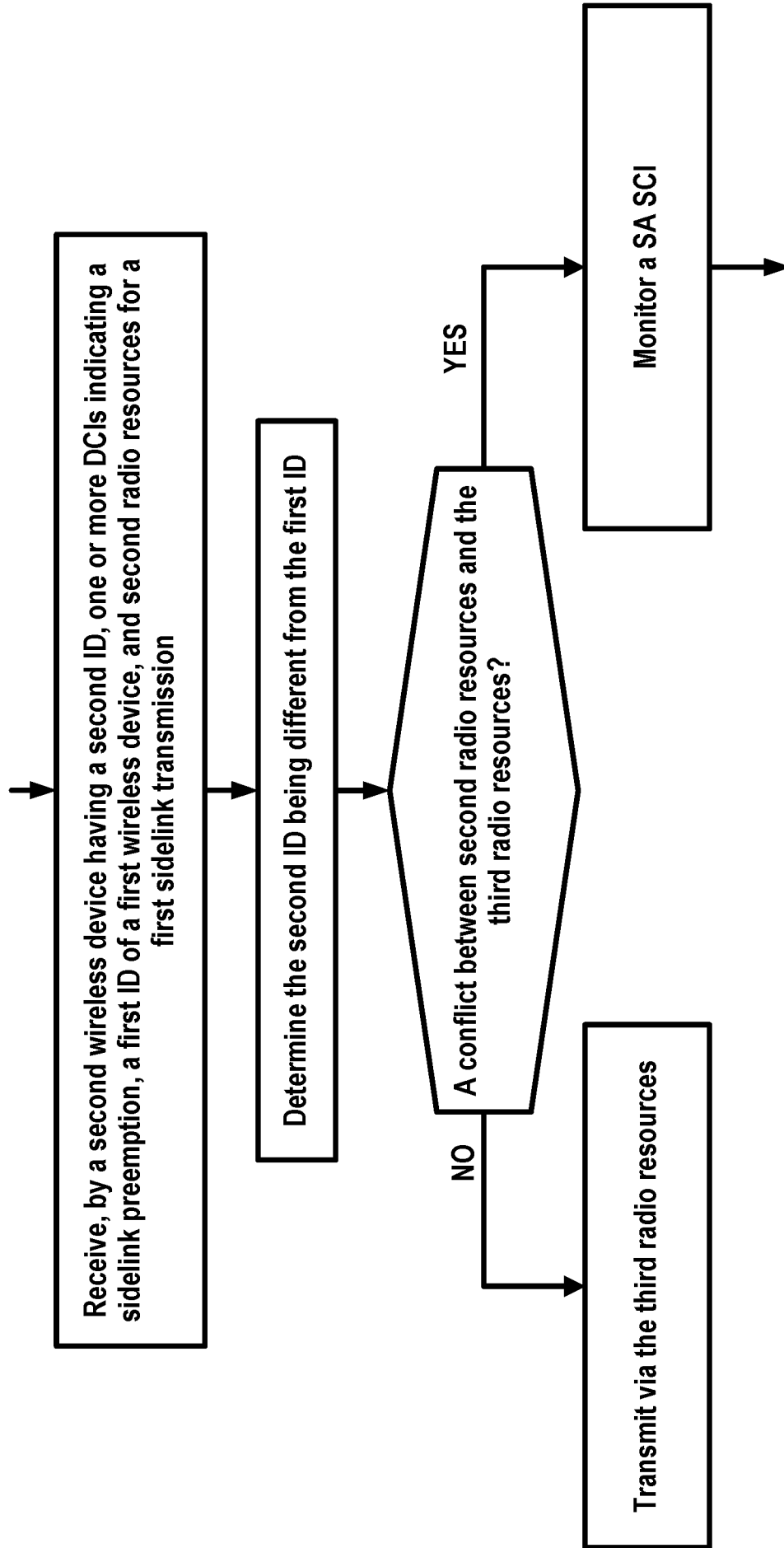

FIG. 37

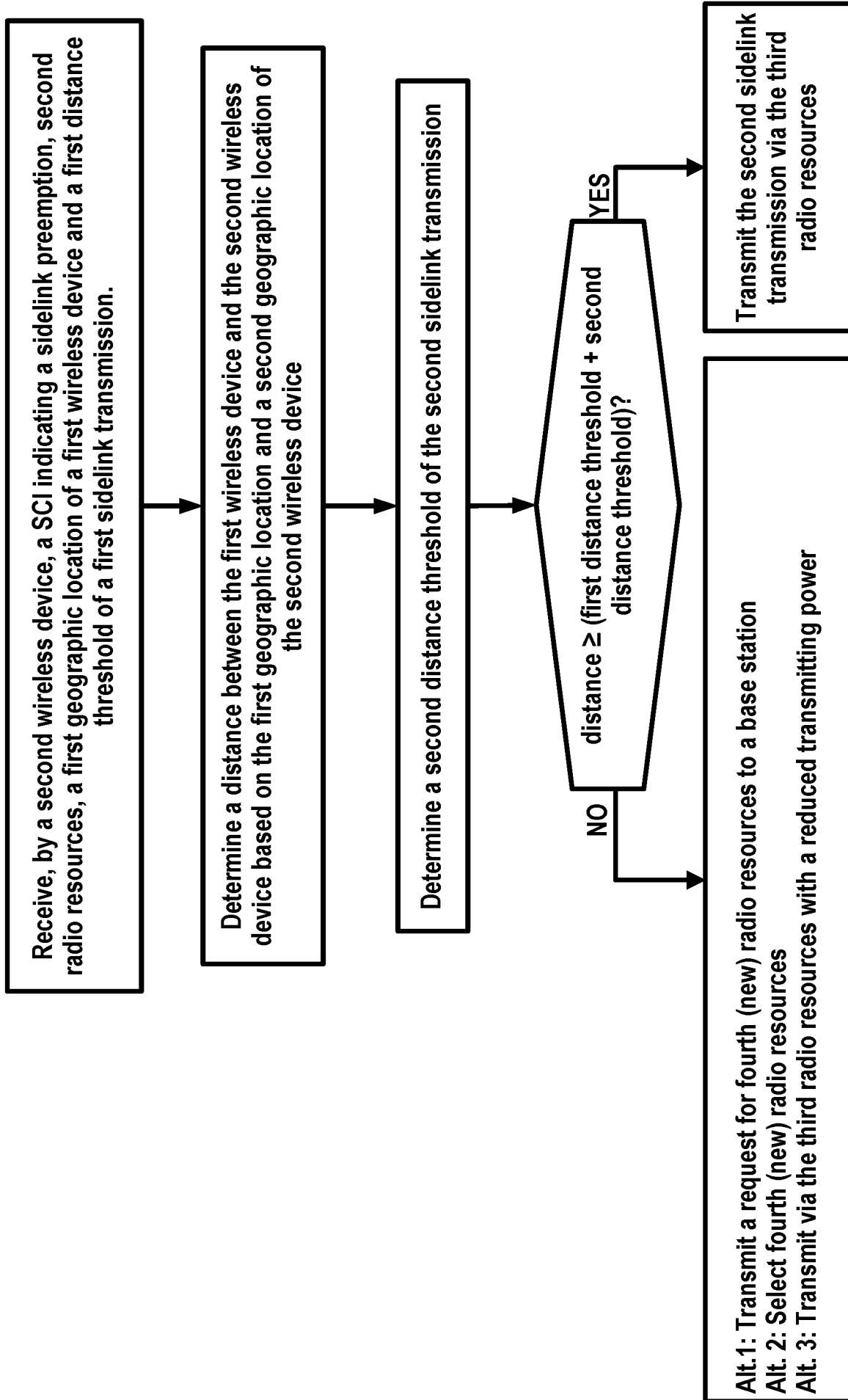

FIG. 38

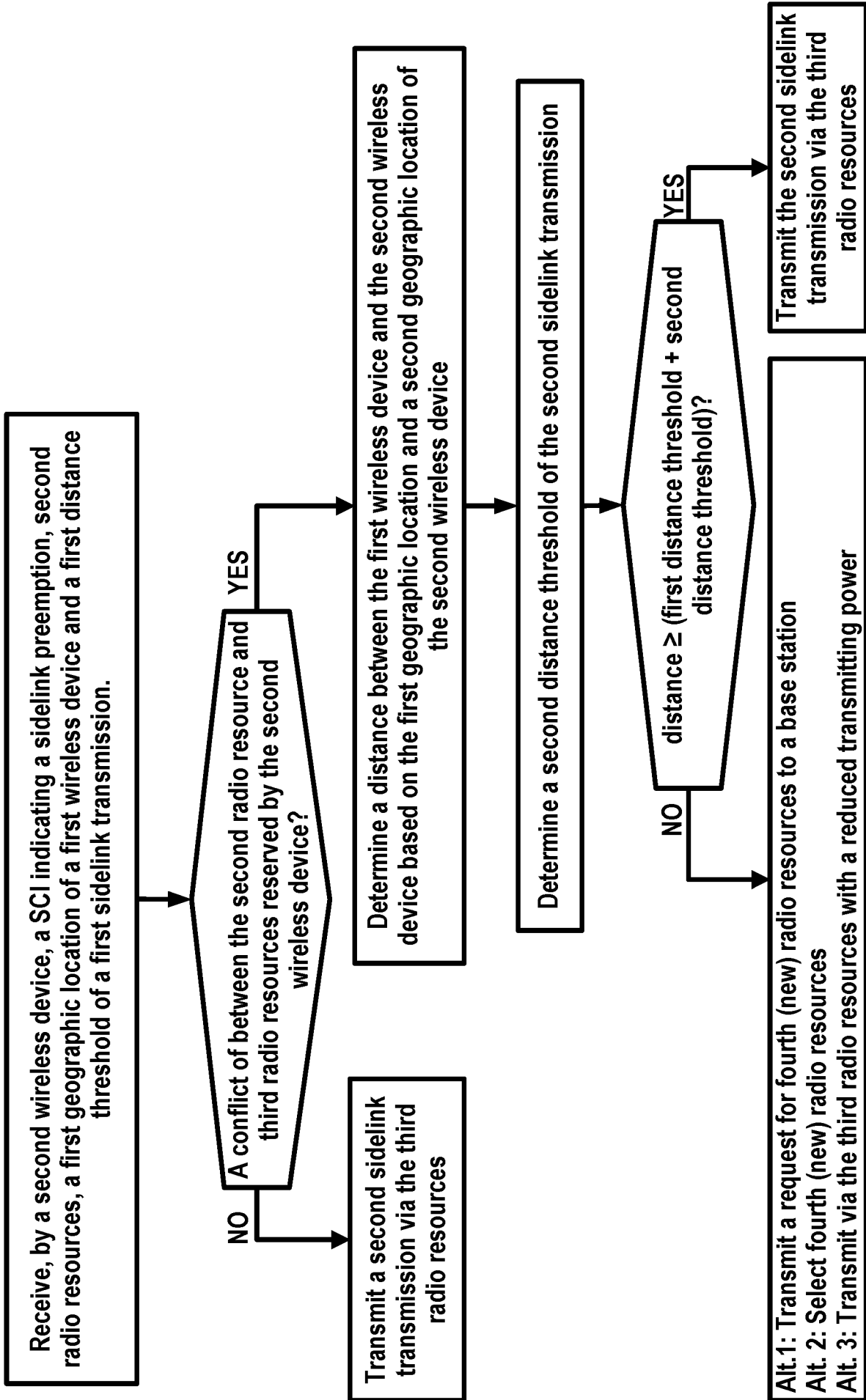

FIG. 39

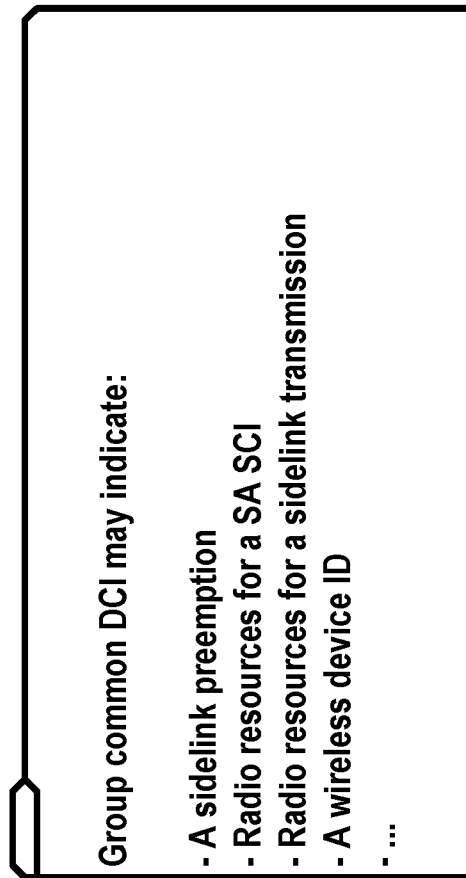

FIG. 40

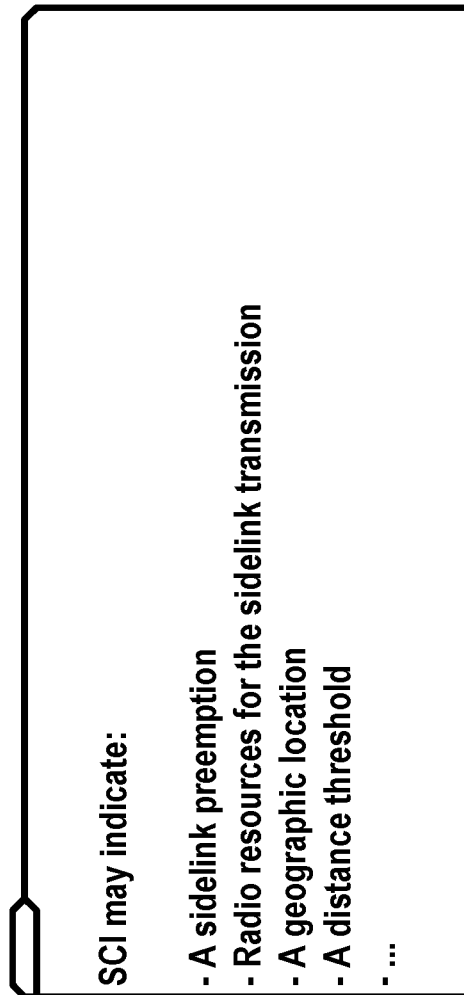

FIG. 41

42/46

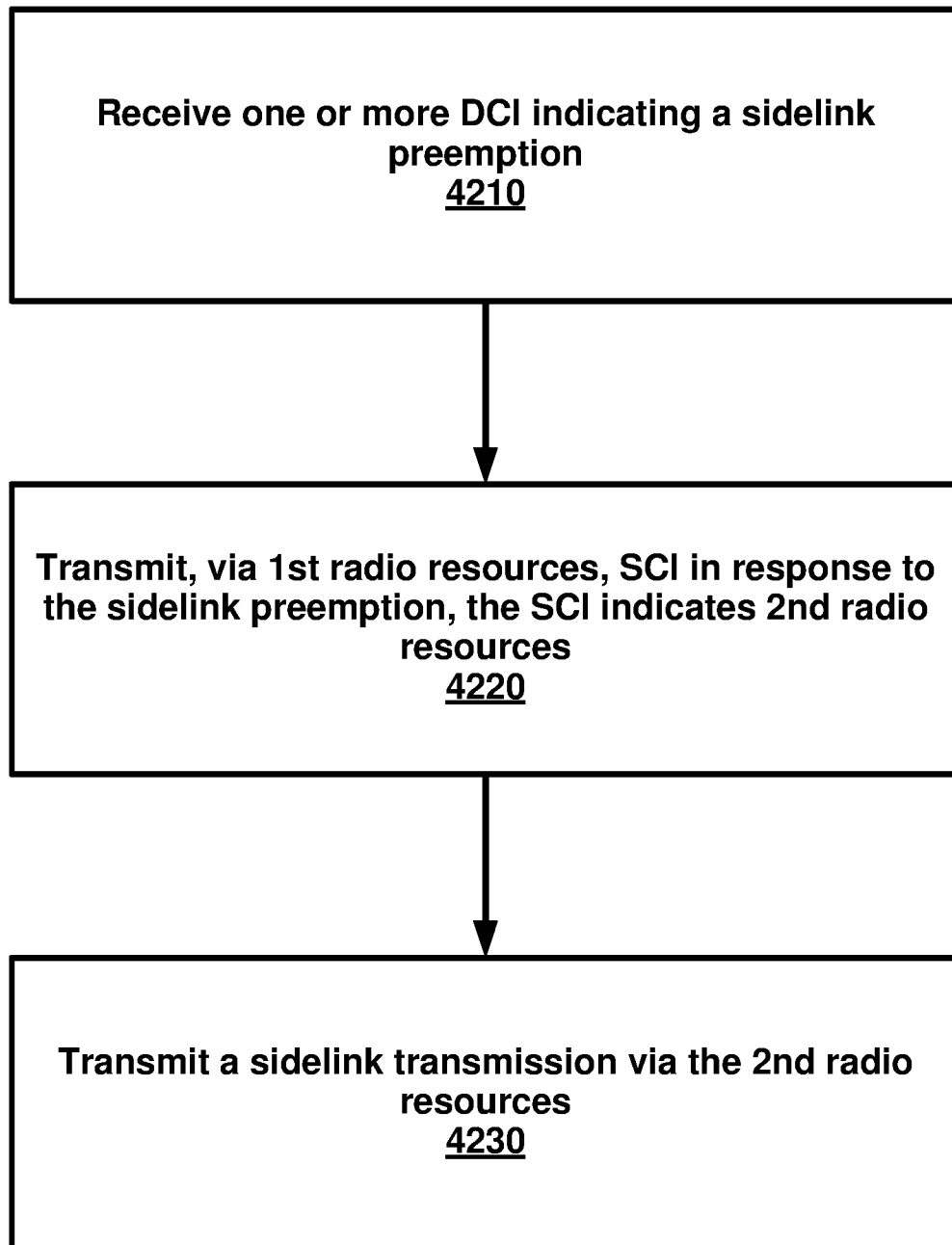

FIG. 42

43/46

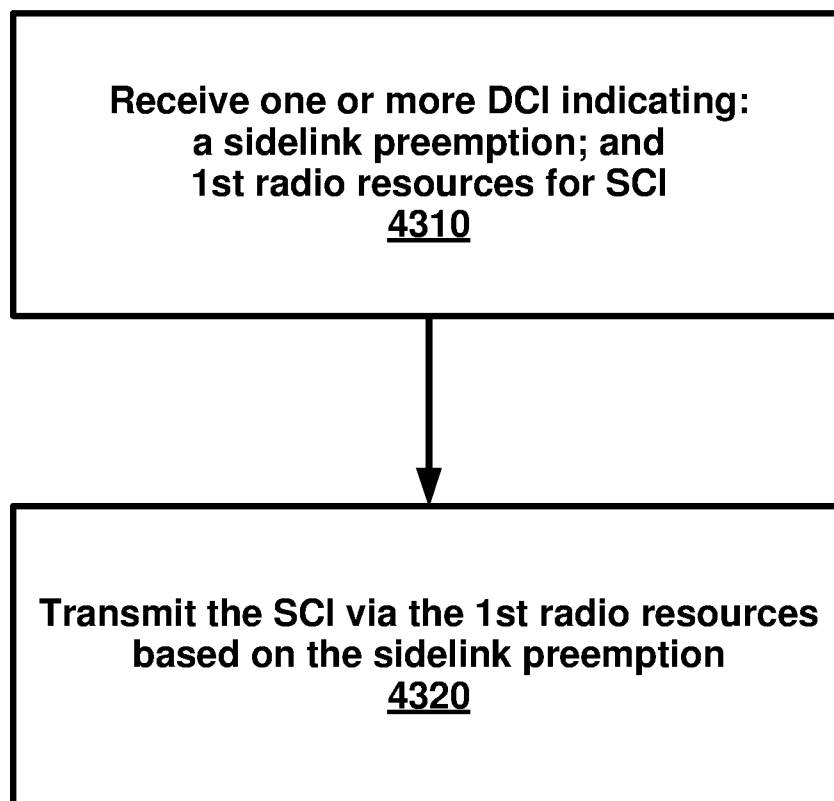
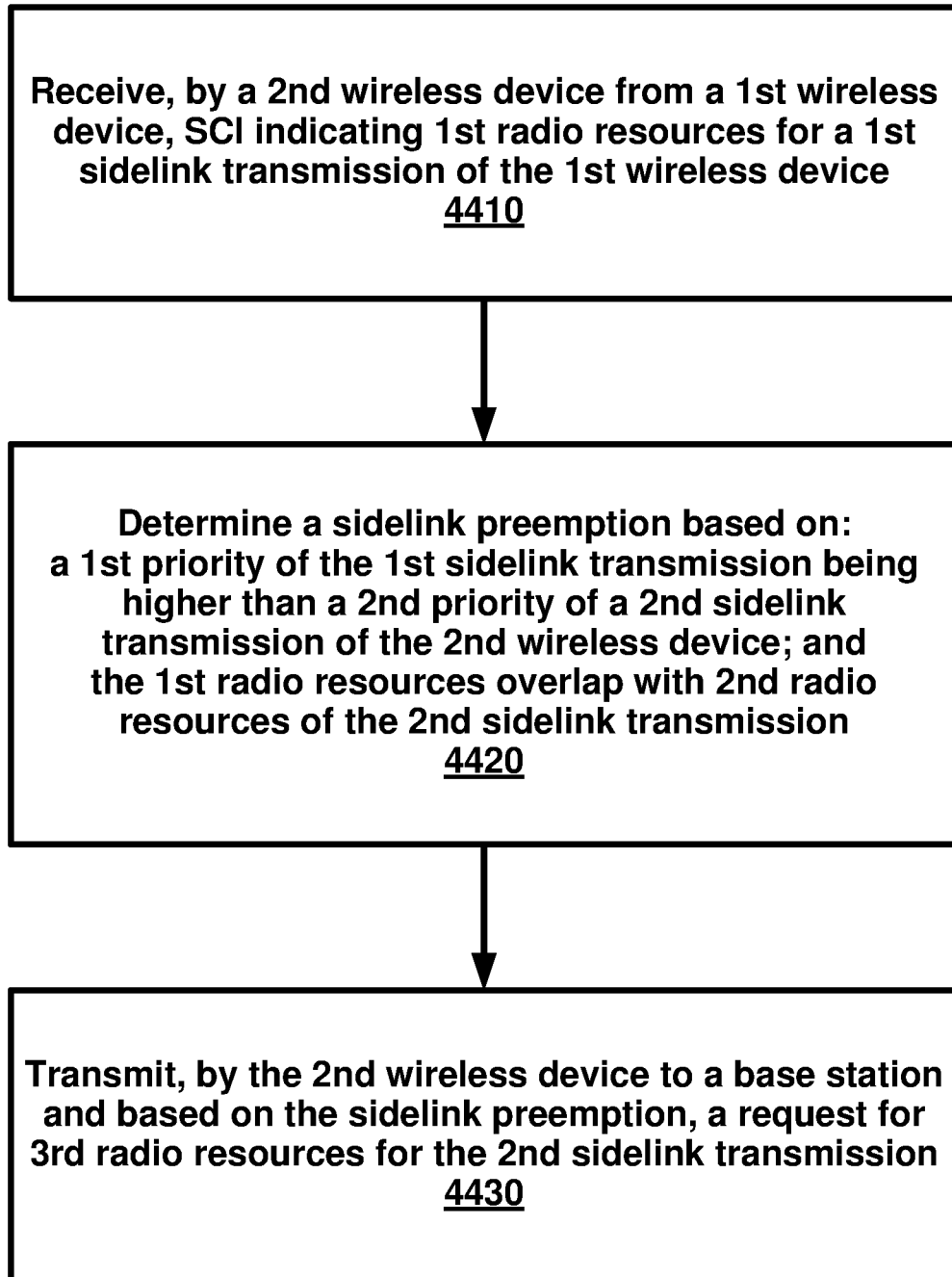
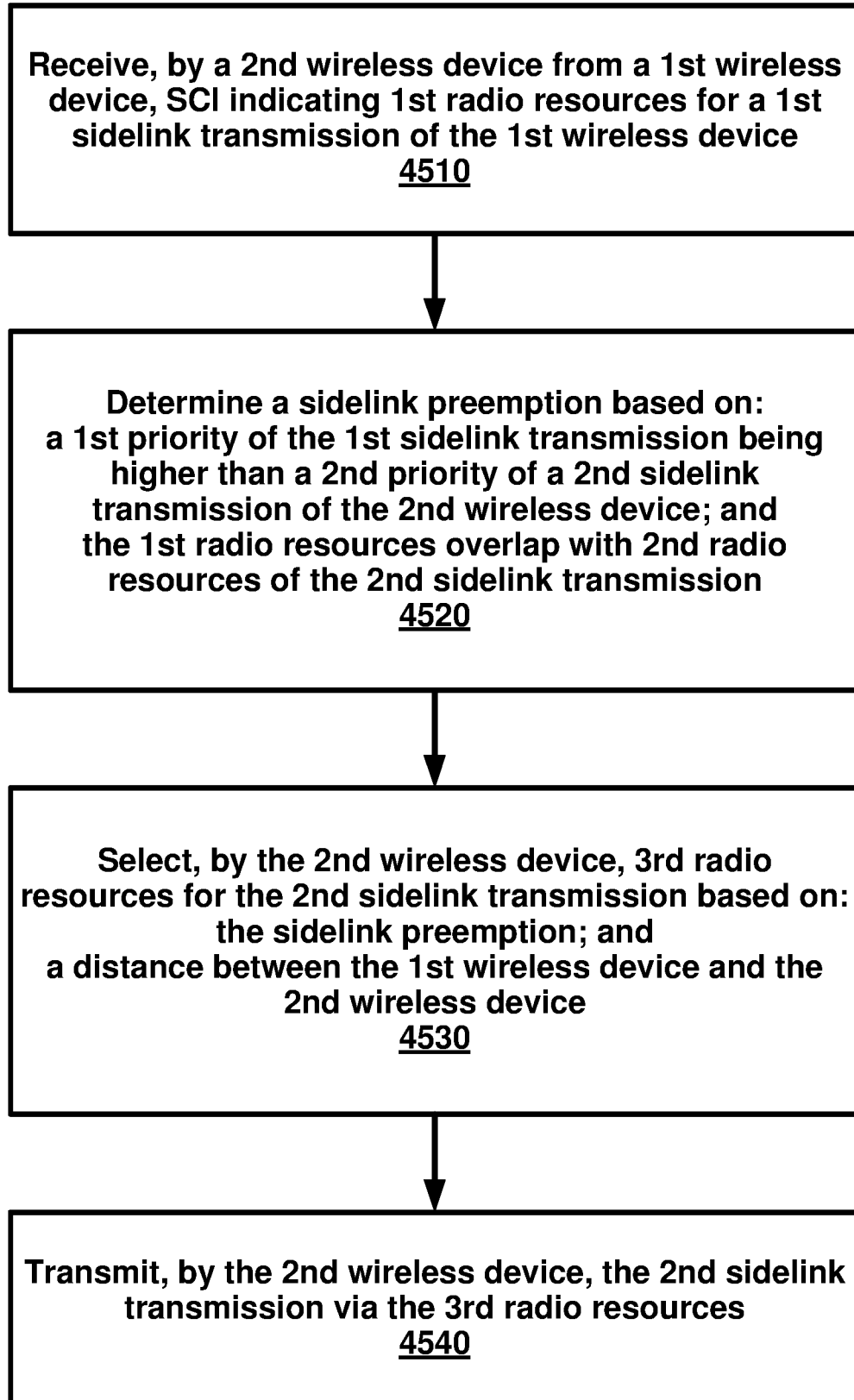
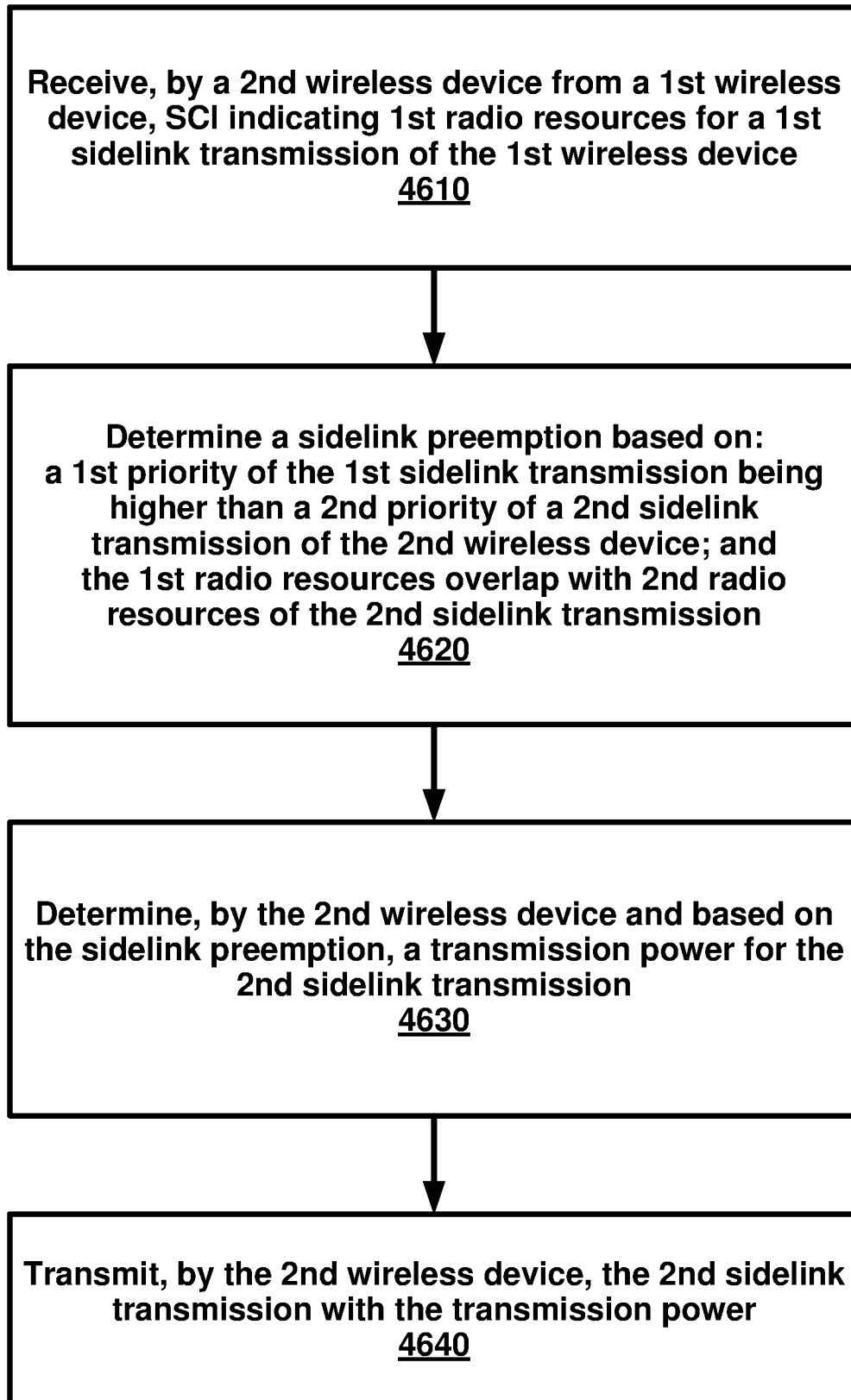

FIG. 43

44/46**FIG. 44**

45/46**FIG. 45**

46/46**FIG. 46**

INTERNATIONAL SEARCH REPORT

International application No
PCT/US2020/046462

A. CLASSIFICATION OF SUBJECT MATTER
INV. H04L5/00 H04W72/12 H04W88/04
ADD.
According to International Patent Classification (IPC) or to both national classification and IPC

B. FIELDS SEARCHED
Minimum documentation searched (classification system followed by classification symbols)
H04L H04W

Documentation searched other than minimum documentation to the extent that such documents are included in the fields searched

Electronic data base consulted during the international search (name of data base and, where practicable, search terms used)
EPO-Internal, WPI Data

C. DOCUMENTS CONSIDERED TO BE RELEVANT

Category*	Citation of document, with indication, where appropriate, of the relevant passages	Relevant to claim No.
X	CAICT: "Considerations on Pre-emption Issue in RA of NR V2X Sidelink Design", 3GPP DRAFT; R1-1901127, 3RD GENERATION PARTNERSHIP PROJECT (3GPP), MOBILE COMPETENCE CENTRE ; 650, ROUTE DES LUCIOLES ; F-06921 SOPHIA-ANTIPOLIS CEDEX ; FRANCE vol. RAN WG1, no. Taipei; 20190125 - 20190201 20 January 2019 (2019-01-20), XP051593971, Retrieved from the Internet: URL:http://www.3gpp.org/ftp/Meetings%5F3GPP P%5FSYNC/RAN1/Docs/R1%2D1901127%2Ezip [retrieved on 2019-01-20]	1-8, 16-20, 22-24, 70-73
Y	pages 1, 5; figures 1, 3-3,5, 7 ----- -/--	9-15, 25-31

Further documents are listed in the continuation of Box C.

See patent family annex.

* Special categories of cited documents :

- "A" document defining the general state of the art which is not considered to be of particular relevance
- "E" earlier application or patent but published on or after the international filing date
- "L" document which may throw doubts on priority claim(s) or which is cited to establish the publication date of another citation or other special reason (as specified)
- "O" document referring to an oral disclosure, use, exhibition or other means
- "P" document published prior to the international filing date but later than the priority date claimed

- "T" later document published after the international filing date or priority date and not in conflict with the application but cited to understand the principle or theory underlying the invention
- "X" document of particular relevance; the claimed invention cannot be considered novel or cannot be considered to involve an inventive step when the document is taken alone
- "Y" document of particular relevance; the claimed invention cannot be considered to involve an inventive step when the document is combined with one or more other such documents, such combination being obvious to a person skilled in the art
- "&" document member of the same patent family

Date of the actual completion of the international search 11 November 2020	Date of mailing of the international search report 18/01/2021
Name and mailing address of the ISA/ European Patent Office, P.B. 5818 Patentlaan 2 NL - 2280 HV Rijswijk Tel. (+31-70) 340-2040, Fax: (+31-70) 340-3016	Authorized officer Vucic, Jelena

INTERNATIONAL SEARCH REPORT

International application No

PCT/US2020/046462

C(Continuation). DOCUMENTS CONSIDERED TO BE RELEVANT		
Category*	Citation of document, with indication, where appropriate, of the relevant passages	Relevant to claim No.
X	INTEL CORPORATION: "Uu-based Sidelink Resource Allocation for V2X Use Cases", 3GPP DRAFT; R1-1902486 INTEL - EV2X_SL_CTRL, 3RD GENERATION PARTNERSHIP PROJECT (3GPP), MOBILE COMPETENCE CENTRE ; 650, ROUTE DES LUCIOLES ; F-06921 SOPHIA-ANTIPOLIS CEDEX ; FRANCE vol. RAN WG1, no. Athens, Greece; 20190225 - 20190301 16 February 2019 (2019-02-16), XP051600182, Retrieved from the Internet: URL: http://www.3gpp.org/ftp/tsg%5Fran/WG1%5FRL1/TSGR1%5F96/Docs/R1%2D1902486%2Ezip [retrieved on 2019-02-16]	1-8, 16-20, 22-24, 70-73
Y	Section 4.2	9-15, 25-31
Y	----- US 2018/206260 A1 (KHORYAEV ALEXEY [RU] ET AL) 19 July 2018 (2018-07-19)	9-15, 25-31
A	paragraphs [0032], [0047]; figure 16	1,2,4-6, 16,18,19
A	----- US 2018/324882 A1 (GULATI KAPIL [US] ET AL) 8 November 2018 (2018-11-08) paragraph [0073]	8,24
A	----- US 2017/041902 A1 (SHENG JIA [US]) 9 February 2017 (2017-02-09) the whole document -----	1-31, 70-73

INTERNATIONAL SEARCH REPORT

International application No.
PCT/US2020/046462

Box No. II Observations where certain claims were found unsearchable (Continuation of item 2 of first sheet)

This international search report has not been established in respect of certain claims under Article 17(2)(a) for the following reasons:

1. Claims Nos.:
because they relate to subject matter not required to be searched by this Authority, namely:

2. Claims Nos.:
because they relate to parts of the international application that do not comply with the prescribed requirements to such an extent that no meaningful international search can be carried out, specifically:

3. Claims Nos.:
because they are dependent claims and are not drafted in accordance with the second and third sentences of Rule 6.4(a).

Box No. III Observations where unity of invention is lacking (Continuation of item 3 of first sheet)

This International Searching Authority found multiple inventions in this international application, as follows:

see additional sheet

1. As all required additional search fees were timely paid by the applicant, this international search report covers all searchable claims.

2. As all searchable claims could be searched without effort justifying an additional fees, this Authority did not invite payment of additional fees.

3. As only some of the required additional search fees were timely paid by the applicant, this international search report covers only those claims for which fees were paid, specifically claims Nos.:

4. No required additional search fees were timely paid by the applicant. Consequently, this international search report is restricted to the invention first mentioned in the claims; it is covered by claims Nos.:

1-31, 72, 73(completely); 70, 71(partially)

Remark on Protest

- The additional search fees were accompanied by the applicant's protest and, where applicable, the payment of a protest fee.
- The additional search fees were accompanied by the applicant's protest but the applicable protest fee was not paid within the time limit specified in the invitation.
- No protest accompanied the payment of additional search fees.

FURTHER INFORMATION CONTINUED FROM PCT/ISA/ 210

This International Searching Authority found multiple (groups of) inventions in this international application, as follows:

1. claims: 1-31, 72, 73(completely); 70, 71(partially)

receiving, by a first wireless device, one or more downlink control information (DCI) indicating a sidelink preemption; transmitting, via first radio resources, sidelink control information (SCI) in response to the sidelink preemption, wherein the SCI indicates second radio resources; and transmitting a sidelink transmission via the second radio resources.

2. claims: 32-69, 74-76(completely); 70, 71(partially)

receiving, by a second wireless device from a first wireless device, sidelink control information (SCI) indicating first radio resources for a first sidelink transmission of the first wireless device; determining a sidelink preemption based on: a first priority of the first sidelink transmission being higher than a second priority of a second sidelink transmission of the second wireless device; and the first radio resources overlap with second radio resources of the second sidelink transmission; and transmitting, by the second wireless device to a base station and based on the sidelink preemption, a request for third radio resources for the second sidelink transmission.

INTERNATIONAL SEARCH REPORT

Information on patent family members

International application No

PCT/US2020/046462

Patent document cited in search report	Publication date	Patent family member(s)	Publication date
US 2018206260 A1	19-07-2018	EP 3335495 A1	20-06-2018
		EP 3764722 A1	13-01-2021
		US 2018206260 A1	19-07-2018
		US 2020015255 A1	09-01-2020
		WO 2017026973 A1	16-02-2017

US 2018324882 A1	08-11-2018	CN 110771257 A	07-02-2020
		EP 3620031 A1	11-03-2020
		TW 201844026 A	16-12-2018
		US 2018324882 A1	08-11-2018
		WO 2018204130 A1	08-11-2018

US 2017041902 A1	09-02-2017	AU 2016307444 A1	15-02-2018
		CN 108141847 A	08-06-2018
		EP 3332593 A1	13-06-2018
		JP 6746624 B2	26-08-2020
		JP 2018522478 A	09-08-2018
		US 2017041902 A1	09-02-2017
		WO 2017027375 A1	16-02-2017
