



- (51) International Patent Classification: *G09B 3/00* (2006.01)
- (21) International Application Number: PCT/US2012/054940
- (22) International Filing Date: 12 September 2012 (12.09.2012)
- (25) Filing Language: English
- (26) Publication Language: English
- (30) Priority Data: 2576/MUM/2011 13 September 2011 (13.09.2011) IN
- (71) Applicants (for all designated States except US): **MONK AKARSHALA DESIGN PRIVATE LIMITED** [IN/IN]; 1103, A Wing, Hillside, Raheja Vihar, Powai, Mumbai, Maharashtra 400072 (IN). **MONK AKARSHALA INC.** [US/US]; 5325 Elkhorn Blvd., #8109, Sacramento, CA 95842 (US).
- (72) Inventor; and
- (75) Inventor/Applicant (for US only): **KAPOOR, Samridh** [IN/IN]; C/o Monk Akarshala Design Private Limited, 1103, A Wing, Hillside, Raheja Vihar, Powai, Mumbai, Maharashtra 400072 (IN).
- (74) Agents: **HOPEWELL, Gregory, A.** et al.; Fenwick & West LLP, Silicon Valley Center, 801 California Street, Mountain View, CA 94041 (US).
- (81) Designated States (unless otherwise indicated, for every kind of national protection available): AE, AG, AL, AM, AO, AT, AU, AZ, BA, BB, BG, BH, BN, BR, BW, BY,

[Continued on next page]

(54) Title: RECRUITMENT SYSTEMS AND METHODS IN A MODULAR LEARNING SYSTEM

(57) Abstract: A modular learning system provides recruiting systems and methods to a recruiting user. A recruiting user provides a recruiting request to the modular learning system. The recruiting request specifies learning applications and minimum performance metrics for users qualifying for recruitment. Learning users who have performed the learning applications at the specified performance metrics are eligible for recruitment by the recruiting user and may be provided an interview with the recruiting user.

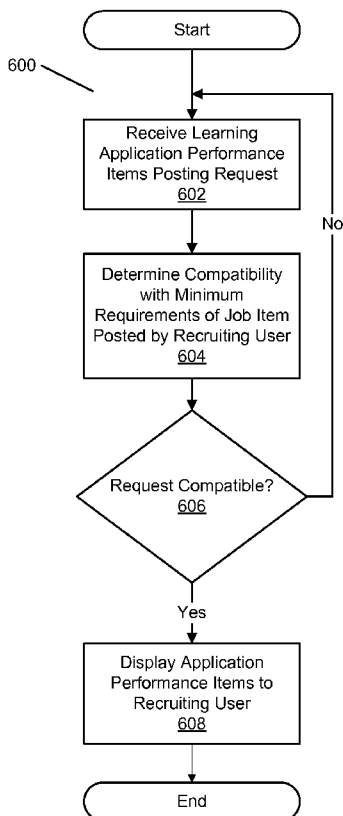

FIG. 6

WO 2013/040092 A1

BZ, CA, CH, CL, CN, CO, CR, CU, CZ, DE, DK, DM, DO, DZ, EC, EE, EG, ES, FI, GB, GD, GE, GH, GM, GT, HN, HR, HU, ID, IL, IN, IS, JP, KE, KG, KM, KN, KP, KR, KZ, LA, LC, LK, LR, LS, LT, LU, LY, MA, MD, ME, MG, MK, MN, MW, MX, MY, MZ, NA, NG, NI, NO, NZ, OM, PA, PE, PG, PH, PL, PT, QA, RO, RS, RU, RW, SC, SD, SE, SG, SK, SL, SM, ST, SV, SY, TH, TJ, TM, TN, TR, TT, TZ, UA, UG, US, UZ, VC, VN, ZA, ZM, ZW.

GM, KE, LR, LS, MW, MZ, NA, RW, SD, SL, SZ, TZ, UG, ZM, ZW), Eurasian (AM, AZ, BY, KG, KZ, RU, TJ, TM), European (AL, AT, BE, BG, CH, CY, CZ, DE, DK, EE, ES, FI, FR, GB, GR, HR, HU, IE, IS, IT, LT, LU, LV, MC, MK, MT, NL, NO, PL, PT, RO, RS, SE, SI, SK, SM, TR), OAPI (BF, BJ, CF, CG, CI, CM, GA, GN, GQ, GW, ML, MR, NE, SN, TD, TG).

**Published:**

— with international search report (Art. 21(3))

**(84) Designated States** (unless otherwise indicated, for every kind of regional protection available): ARIPO (BW, GH,

## **RECRUITMENT SYSTEMS AND METHODS IN A MODULAR LEARNING SYSTEM**

INVENTOR:

SAMRIDH KAPOOR, MUMBAI, INDIA

### **CROSS REFERENCE TO RELATED APPLICATIONS**

**[0001]** This application claims the benefit of Indian Provisional Specification No. 2576/MUM/2011, titled "Recruitment System and Methods in A Modular Learning System" filed on 13-September-2011, which is incorporated by reference in its entirety.

### **FIELD OF THE ART**

**[0002]** The present invention relates generally to modular learning systems, and more particularly to learner recruitment systems and methods in a modular learning system.

### **DESCRIPTION OF THE RELATED ART**

**[0003]** The current education environment includes members like students or learners, teachers, tutors, coaches, guides, professors or lecturers, content authors, and organizational members like preschools, schools, colleges, universities, educational boards and professional standards authorities, admission testing authorities, placement organizations, recruiters, HR departments of organizations, educational content and media publishers and local, regional, and national governments. All the above maintain some form of transactional and functional relationships with each other. Conventionally, a large number of placement organizations, recruiters, HR departments of organizations and educational institutions like colleges and universities provide placement services, or in case of HR departments, internal placement services, to students based partly on the educational qualifications like a degree or certification gained at a particular educational institution or training organization, or from a particular professional standards authority, in some cases the same authority or institution offering such placement services. Such placements may be managed by an applicant tracking system or a human resources management system of an organization, or a placement management system of an educational institution, with many particulars of each student, including job preferences and preferred placement companies present, updated and displayed to the corresponding authorized representatives of such organizations and such educational institutions. Recently, modular learning systems enable a plurality of kinds of users to establish transactional and functional relationships with each other, and such users include a

plurality of learning users and recruiting users, in addition to a plurality of learning applications.

**[0004]** However, some modular learning systems, especially those offering the purchase and performance of discrete microlearning experiences may find it difficult to offer employment opportunities to learning users in the manner used to offer the same to students of educational institutions in the traditional education environment, as each learning user may have completed a unique set of learning application performances on the said system, and a recruiting organization which generally defines the educational requirements of a potential employee, does so in the format of an accredited degree, course, program or equivalent requirement, all of which may not be offered by a modular learning system due to each learning user completing a unique set of learning application performances, and doing so indefinitely, with no traditional placement season due to a lack of an end date of a course, program or degree.

**[0005]** What is needed in the art is a system and method for recruiting users in a modular learning system to manage learning application based recruitments and, optionally, learning application based interview performances, based on the learning application performance experience and corresponding scores or reviews of a plurality of learning users on the said modular learning system through a learner recruitment management interface generated and displayed with corresponding input areas to each recruiting user on each said user's user device. Further, what is needed in the art is a system and method for learning users in a modular learning system to post performance data like score and review items for non interview-related learning application performances conducted earlier by the each said learning user on or through the said modular learning system, to a plurality of compatible recruiting users on the modular learning system. Further, what is needed in the art is a system and method for the modular learning system to receive a recruitment request from a recruiting user, determine the application particulars and, optionally, minimum metrics scores for each learning application in the job requirement and, optionally, manage and process the interview performance of one, some or all of plurality of learning applications in each recruitment request made by each recruiting user. Finally, what is needed in the art is a system and method for the modular learning system to receive a performance scores or reviews items posting request from the learning user, determine compatibility to minimum requirements like learning application requirements and, optionally, metrics/scores for the said learning applications and to display the said items to compatible recruiting users through a learner recruitment management interface on each said recruiting user's user device.

## BRIEF DESCRIPTION OF DRAWINGS

[0006] The disclosed embodiments have other advantages and features which will be more readily apparent from the detailed description, the appended claims, and the accompanying figures (or drawings). A brief introduction of the figures is below.

[0007] Figure (FIG.) 1 is a modular learning environment including a modular learning system 144 according to one embodiment.

[0008] FIG. 2 is a block diagram of a modular learning system according to one embodiment.

[0009] FIG. 3A is a block diagram of a learning application according to one embodiment.

[0010] FIG. 3B is a block diagram of a learning application according to an alternative embodiment.

[0011] FIG. 4 is a block diagram of the learner recruitment management module according to one embodiment.

[0012] FIG. 5 is a flow diagram of the method for recruiting user to manage learner recruitments in a modular learning system environment according to one embodiment.

[0013] FIG. 6 is a flow diagram of the method for a learning user to post performance data to a recruiting user in a modular learning system environment according to one embodiment.

[0014] FIG. 7 illustrates modules of an example machine able to read instructions from a machine-readable medium and execute them in a processor (or controller) according to one embodiment.

## DETAILED DESCRIPTION

[0015] A system and method of a recruiting user to manage learner recruitments in a modular learning system environment is provided. Further, a system and method for a learning user to post performance data to a recruiting user in a modular learning system environment is provided. The learner recruitment management module in the modular learning system 144 may comprise a plurality of modules and generators like a skills database module, an interview performance items module, a job items module, a learning application database module, an access control module, a recruiting user organization database module and a recruitment interface generator. The method of recruiting user to managing recruitments in a modular learning system environment may comprise a plurality of steps like receiving a learning user recruiting request from a recruiting user, determining particulars of

the learning user recruitment request, determining minimum metrics scores for each learning application in a job requirement, displaying interview confirmation to a learning user, determining trial performance availability, granting trial performance request, displaying application review on recruiter device screen, receiving recruiter review data, determining recruitment of the learning user displaying a 'job denied' status to the learning user in some embodiments, displaying a 'job confirmed' status to the learning user in other embodiments, and adding the learning user to recruiting user's organization database in such embodiments. The method for a learning user to post performance data to a recruiting user in a modular learning system environment may comprise a plurality of steps like receiving a learning performance posting request from a learning user, determining compatibility to minimum requirements of a recruiting user, and displaying learning performance items to the recruiting user.

#### CONFIGURATION OVERVIEW

**[0016]** A system and method of managing the purchase and performance of a learning application and associated application services stack is provided. A modular learning system 144 stores and manages a plurality of learning applications. For example, a learning application may relate to learning to swim, learning a level of mathematics, or learning a martial art. The learning application may relate to fact-based lesson, such as a history lesson, to a performance-based skill, such as swimming, or to a creative skill such as writing and directing a play. The learning applications comprise learning content and metadata for determining compatibility of the learning application with users and learning services required for performing the learning application. Prior to purchasing and using a learning application, a learning user is verified as compatible for receiving and using the learning application. Learning applications are described in further detail below.

**[0017]** Learning users purchasing a learning application may select learning service providers compatible with the particular learning application in order to learn the content of the learning application. Such learning services may include access to a learning facility, learning tools, learning aids, learning materials, tutoring services, testing services and other services. Each of these learning services may be selected by the learning user 102 and may be provided by a different entity. Each learning application comprises a plurality of kinds of application metadata in addition to the instructional content and associated media for a particular topic or subject. The instructional content and media of each learning application may comprise a specific unit of instruction for a particular portion of knowledge or a skill,

and may vary widely in scope. The learning user 102's relationship with the various application service providers is managed through modular learning system 144 with respect to individual learning applications. Each of the learning services is also associated with metadata which may describe aspects of the application services, application service availability, learning users compatible with the application services, schedules, and other aspects of the application services. This metadata relating to the learning services is described in further detail below.

**[0018]** For example, a learning user 102 using the modular learning system 144 may obtain, in micro increments of time and money, tutoring services from a particular tutoring user 112, learning applications from a content application authoring user 104, learning tools, aids or materials from a learning tools supplying user 118, learning visits from a learning visits organizing user 114, learning facility access to a learning facility 132, learning workshop access from a learning workshop organizing user 116 and may wish to seek placement or recruitment at another organization through a user registered on the system as a recruiting user -. The modular learning system 144 enables each of these entities to provide services to the learning user 102 using the learning applications. As such, the modular learning system 144 enables the learning user 102 to identify learning content applications the learning user 102 is interested in, and connecting the learning user 102 with application service providers that can provide distinct application services associated with those learning content applications.

**[0019]** Figure (FIG.) 1 is a modular learning environment 100 including a modular learning system 144 according to one embodiment. Modular learning system 144 operates in modular learning environment 100 and communicates with a plurality of user devices 140 over a network 142. The user devices 140 are operated by a plurality of kinds of users in the learning environment. The user devices 140 may comprise any of a variety of computing devices, such as a desktop computer, a laptop, a mobile device, a tablet computer, a set-top box, a kiosk, interactive television, gaming console, and other computing platforms suitable for communicating with modular learning system 144. The modular learning system 144 provides a system for managing curricula, learning facilities, standardized tests, learning applications, tutors, and other modules of a learning experience in micro increments of time and money. The modular learning system 144 enables the various users to communicate with other users in a learning environment and provide services to learning user 102. The network 142 includes a wireless area network, a local area network, a General Packet Radio Service

(GPRS) network, an Enhanced Data for Global Evolution (EDGE) network and the like. The user devices 140 are connected to the modular learning system 144 via the network 142.

**[0020]** Modular learning system 144 allows a learning user 102 to manage the purchase and performance of each module of a single microlearning service stack for a learning application (e.g. Breaststroke) or a group of learning applications (e.g. Breaststroke, Freestyle, Butterfly and Swimming Safety). Tutor access, such as access to a swimming instructor may be purchased in various increments, such as in hours. Learning content applications such as a breaststroke application with attached instructional media and other data may be purchased in timed access quantities or may be permanently purchased. Learning facility access such as an Olympic Sized Swimming Pool may be purchased in increments of hours or learning application performances such as ten laps. Learning tools or materials such as Swimming Goggles may be purchased as well. Each of these modules may be separately purchased and interacted with through an interface displayed on user device 140. In case of a learning performance which can be completed on the user device 140 itself, the learning application content is not only purchased and managed, but also performed, through an interface displayed on the user device 140. A learning user 102 may manage the purchase and performance of groups of microlearning performances in the form of learning visits and learning workshops, through an interface displayed on user device 140. Learning user 102 may manage an individual learning identity (or learning profile) and offer details of microlearning application performances completed by the learning user, as well as the personal learning metrics, scores, and reviews. This learning identity may be provided to recruiting users for the purpose of placement.

**[0021]** The modular learning system 144 manages, regulates and supervises the purchase, sale, preview, performance and review of a plurality of microlearning applications, each comprised modularly of a tutoring service, a learning application, learning facility access, and/or learning tools or infrastructure access, a learning visit, and/or a workshop as described in further detail below. The modular learning system 144 manages transactional and functional relationships between users of the modular learning system 144. These various users interact with the modular learning system 144 to modify learning applications and provide learning services as described below.

**[0022]** The modular learning system 144 may enable various other users including but not limited to tutors, authors, tool/material suppliers learning application template developers, translators, certifying user, learning facility administrators, learning event organizers, recruiters, and funders to modularly manage at least one of micro tutoring services associated

with specific learning applications, microlearning content applications, microlearning application templates, translation of microlearning content applications, certification of microlearning content applications, access to learning facilities, access to learning workshops, organization of learning visits associated with specific learning applications, supply of tools, aids and/or materials, recruitment services, as well as granular funding services.

**[0023]** The modular learning system 144 enables a tutoring user 112 to provide micro tutoring services to learning user 102. Tutoring user 112 are typically individuals with credentials or other knowledge in the area of learning applications. The tutoring user 112 may associate themselves with particular pieces of content to and may indicate qualifications to teach each learning application, as is described further below. The modular learning system 144 manages the sale of micro tutoring services and associated tutoring user 112 with specific learning applications to learning user 102. Tutoring user 112 assist the learning user 102 with learning the subject matter of the learning application. The tutoring user may provide tutoring to the learning user 102 by meeting the learning user 102 in person to assist the learning user 102 in performing the learning application. As such, the modular learning system 144 facilitates the meeting and communication of tutors and learners. Tutoring user 112 may also provide learning performance data to the modular learning system 144. The learning performance data may indicate, for example, the level of the learner's mastery or proficiency through scoring or other metrics for reviewing performance at a learning performance task. The tutoring user 112 provides input to the modular learning system 144 using a plurality of learning applications through an interface displayed on the tutoring user's 112 user device 140.

**[0024]** The modular learning system 144 enables a learning application authoring user 104 to manage the drafting, editing, testing, publishing, sale and updates of learning content in applications through an interface displayed on user device 140. That is, the learning application authoring user 104 authors individual pieces of learning content which may be purchased and used by a learning user. For example, a learning application authoring user 104 may create instructional content for learning the backstroke. The instructional content may comprise instructions and multimedia, as well as directions for the learning user 102 to practice aspects of the backstroke in a suitable pool. The learning application authoring user 104 may use a pre-existing application template to create the learning application.

**[0025]** The modular learning system 144 enables a learning application template developing user 110 to create learning templates for use in creating learning applications. The

learning application templates provide a framework for creating various types of learning applications. For example, learning application templates may comprise a quiz, simulation, role play, experiment, multimedia material, and other types of learning frameworks. The learning application template developing user 110 may manage the development, testing and sale of the learning application templates to learning application authoring users 104 through an interface displayed on a user device 140.

**[0026]** The modular learning system 144 enables a learning application translating user 106 to manage the translation and translation updates of learning content in applications and sale of such services to microlearning application authors through an interface displayed on a user device 140. The translations are provided to the modular learning system 144 and may be stored with the corresponding learning application to enable providing instructions to learning users 102 in a variety of languages.

**[0027]** The modular learning system 144 enables a learning application certifying user 108 to certify various learning applications according to standards applied by the certifying user 108. Such certifying users may include boards of education at various levels, universities, professional standards groups, and other certification authorities. Certifying users 108 may or may not be formal institutions. For example, a certifying user may include a company establishing a set of learning applications to prepare a candidate for a job with the company. The certifying user 108 manages the certification of each learning application as a part of their respective curricula or syllabi and manages the sale of such certification services to learning application authoring users, through an interface displayed on user device 140.

**[0028]** The learning facility 132 facilitates the performance of specific learning applications available on the modular learning system 144. Learning facility 132 may comprise any location suitable for performing types of learning applications. For example, learning facility 132 may comprise an athletic club, a chemistry lab, a science lab, a university, a library, or a tutor's home. In some embodiments, the modular learning system 144 enables a facility administering user 124 to determine the compatibility of various learning applications which can be performed within learning facility 132 by picking the learning infrastructure available in the learning facility and associating the learning facility 132 with each learning application (e.g. Breaststroke) compatible with the learning infrastructure (e.g. Olympic sized Swimming Pool). In one embodiment, rather than expressly associating the learning facility with individual learning applications, the learning facility administering user 124 indicates to the modular learning system 144 the specific infrastructures and amenities available at the learning facility 132. In this embodiment, the

modular learning system 144 enables a learning user 102 or learning application authoring user 104 to identify a learning facility 132 which is compatible with the learning application based on the infrastructure available at the learning facility 132. The modular learning system 144 may also identify compatible learning facilities based on metadata associated with the learning application and the infrastructure indicated by the learning facility administering user 124.

**[0029]** The learning facility 132 may comprise a variety of types of learning facilities, such as an independent learning facility, institutional learning facility, workplace learning facility, and temporary learning facility. The modular learning system 144 enables an administrator 124 of an independent learning facility owned, managed or franchised by the modular learning system 144 to manage the sale of learning facility access for performances of specific microlearning applications as well as sale of learning tools and materials (e.g. sulphuric acid or swimming goggles) or access to the same in micro increments of time and money (\$six/hour or \$five/learning application performance) depending on multiple factors like the learning infrastructure to be accessed (e.g. Swimming Pool, Computers, Chemistry Lab), number of hours of access, and the like, through an interface displayed on a user device 140.

**[0030]** The modular learning system 144 enables an administrator 124 of an institutional learning facility like a preschool, school, college or university (e.g. Bangalore University) associated, partnered or linked with the modular learning system 144 to, in addition to managing the sale associated with the independent learning facility (e.g. learning facility access for performances of specific microlearning applications), manage the learning performances of a plurality of learners (students or outsiders) across a plurality of learning applications available on the system (with the learning user's explicit consent), optionally delegated to a plurality of teachers, professors, lecturers or coaches registered as tutoring users 112 on the modular learning system 144, through an interface displayed on a user device 140.

**[0031]** The modular learning system 144 enables an administrator 124 of a workspace learning facility associated, partnered or linked with the modular learning system 144 to, in addition to managing the sale associated with the independent learning facility (e.g. learning facility access for performances of specific microlearning applications), manage the learning performances of a plurality of learners (employees) across a plurality of learning applications available on the system (with the learning user's explicit consent), optionally delegated to a plurality of Human Resource Managers, Trainers and/or immediate superiors, registered as

tutoring users 112 on the modular learning system, through an interface displayed on a user device 140.

**[0032]** The modular learning system 144 enables an administrator 124 of a temporary learning facility (e.g. a Cricket Ground available for net practice on Saturdays and Sundays from six in the morning to twelve in midnight) to, in addition to managing the sale associated with the independent learning facility (e.g. learning facility access for performances of specific microlearning applications), manage the hours of accessibility to the designated learning facility, through an interface displayed on a user device 140. In addition to managing the sale and performance of microlearning applications, an administrator of an independent, institutional, workspace, or temporary learning facility may manage the modular purchase of learning infrastructure (e.g. chemistry equipment, computers, cricket stumps) as well as learning tools, aids and materials (e.g. sulphuric acid, swimming goggles, cricket bat) from the modular learning system or a third party, topic wise, subject wise, location wise or otherwise based on the learning applications intended to be offered in the designated learning facility, through an interface displayed on a user device 140.

**[0033]** The modular learning system 144 enables a learning visit organizing user 114 to manage the organization of learning visits, and the sale of learning visits to learning users 102. The learning visit organizing user 114 may also associate a learning visit with compatible microlearning applications. Such learning visits may comprise, for example, a visit to a factory or industrial area, a museum, or a trip to a city. The learning visit organizing user 114 may associate the learning visit with learning applications and manage the learning performances during the learning visits. The management of performances of associated learning applications may be optionally provided by tutoring users 112. The learning visit organizing user 114 communicates with the modular learning system 144 through an interface displayed on a user device 140.

**[0034]** The modular learning system 144 enables a learning workshop organizing user 116 to manage the organization of workshops available to learning users 102. A workshop comprises a plurality of specific microlearning applications to be performed in the workshop, and a sequence of the microlearning applications to be performed at the workshop. The workshop may also specify learning tools, a designated learning facility, and a tutoring user or tutoring users to perform the workshop. As such, the workshop user organizes performance and modules of learning applications to be performed together with a group of learning users 102. The learning workshop organizing users 116 also manage the sale of such microlearning workshop access and manage the learning performances for a plurality of

learners. The learning workshop organizing users communicate with the modular learning system 144 through an interface displayed on a user device 140.

**[0035]** The modular learning system 144 enables a learning tools supplying user 118 to provide learning tools and materials such as chemicals, biology samples, computer software, and other materials for use with learning applications to learning users 102. The learning tools supplying user 118 manages the organization and sale of the learning tools and materials (or optionally, access to the same) to learning users and administrators of learning facility 132. The learning tools supplying user 118 may also associate learning tools with particular learning applications stored on modular learning system 144. Alternatively, the learning tools supplying user 118 may designate the tools available and the modular learning system 144 may determine which learning applications may require the tools provided by the learning tools supplying user 118. The learning tools supplying user communicates with the modular learning system 144 through an interface displayed on a user device 140.

**[0036]** The modular learning system 144 enables a recruiter 120 of learning users 102 to manage the recruitment of learning users 102 through the modular learning system 144. The recruiter 120 may view and filter learning users 102 by specific learning applications performed on the system, scores, metrics and reviews generated in relation to the learning applications performed by learning users 102. The recruiter may access and filter learning users 102 based on demographic data like the language used in performing the learning application. Recruiting user 120 may also operate as a certifying user 108 to certify particular learning applications that may be desirable to the recruiting user 120. The recruiting user may use the certified application as a filter prior considering learning users for a position. The recruiting user 120 manages recruiting access to the modular learning system 144 through an interface displayed on a user device 140.

**[0037]** The modular learning system 144 enables a funding user 122 of learning users 102 to provide funding and scholarship funds and other support to learning users 102. Such funding users 122 may comprise a parent, sibling, friend, spouse, relative, university, employer, or scholarship/ grant offering institution. The funds may be provided for the funding of specific learning users or of specific learning applications, or of specific microlearning goods and services associated with the specific learning applications, in small increments, through an interface displayed on a user device 140.

**[0038]** Although the modular learning environment 100 is described as being composed of various, user devices (e.g. personal computer), a network (e.g. internet, intranet, world wide web), learning facilities (e.g. an Independent Learning Facility, an Institutional

Learning Facility), it would be appreciated by one skilled in the art that fewer or more kinds of users (e.g. a Learning Application Fact Checking User, a Web Based Offsite Tutoring User), user devices (e.g. a mobile phone device, a portable gaming console device, a tablet device, a learning console device, gaming console device or server device attached to a television or other screen), networks (e.g. an intranet at a preschool, school, college, university, educational board, professional standards authority, coaching/tuition class; a social or professional network; an intranet at a company, HR department, training department and at a training organization) and learning facilities may comprise the modular learning environment 100, with the present disclosure still falling within the scope of various embodiments.

**[0039]** FIG. 2 is a block diagram of a modular learning system 144 according to one embodiment. The modular learning system 144 includes a variety of databases and modules for providing learning applications and learning services to users of the modular learning system 144. The modular learning system 144 maintains learning applications in a learning application database 204. The learning applications are sold to users along with microlearning services using the purchase management module 238. Performance of learning applications is enabled by performance management module 240. Additional modules of the modular learning system 144 are described below.

**[0040]** A user database 202 is configured for receiving, storing, updating and retrieving a plurality of data fields of each user, such as the user's name, address, and contact details. Depending on the user's role in the modular learning system 144, the user database 202 maintains additional information on the user. For example, for a learning user 102, the user database 202 maintains learning history outside the modular learning system 144, learning application performance history on the modular learning system 144, purchase history of learning applications as well as purchase history of a host of related microlearning purchase items like, for example, timed access to learning facility 132, timed access to tutor 112, and purchase of access to a learning tool from learning tools database 232. In some embodiments, the data fields are used to determine purchase compatibility using purchase management module 238 and to determine performance compatibility using performance management module 240.

**[0041]** The user database 202 may maintain information about each type of user based on the user's role in the system. The user information may be stored in a plurality of databases, each database associated with a user role, or the user roles may be stored in a single user database 202. For example, the additional user roles include learning application authoring

users, learning facility administering users, learning visit organizing users, learning facility administering users, and other types of users of the modular learning system 144.

**[0042]** In one embodiment, a distinct Learning User Database is configured for receiving, storing, updating and retrieving a plurality of data fields of each learning user 102, comprising the learning user's name, address, contact details as well as learning related data fields like learning history outside the modular learning system 144, learning application performance history on the modular learning system 144, purchase history of learning applications as well as purchase history of a host of related microlearning purchase items like, for example, access to learning facility 132, access to tutor 112, and purchase of access to an learning tool. In one embodiment, a distinct Learning Application Authoring User Database is configured for receiving, storing, updating and retrieving a plurality of data fields of each learning application authoring user, say, user 104. In one embodiment, a distinct Independent Learning Facility Administering User Database is configured for receiving, storing, updating and retrieving a plurality of data fields of each independent learning facility administering user, say, user 124. In one embodiment, a distinct Learning Tools Supplying User Database is configured for receiving, storing, updating and retrieving a plurality of data fields of each learning tools supplying user, say, user 118. In one embodiment, a distinct Learning Visit Organizing User Database is configured for receiving, storing, updating and retrieving a plurality of data fields of each learning visit organizing user 114. In one embodiment, a distinct Learning Application Translating User Database is configured for receiving, storing, updating and retrieving a plurality of data fields of each learning application translating user, say, user 106. In one embodiment, a distinct Learning Application Certifying User Database is configured for receiving, storing, updating and retrieving a plurality of data fields of each learning application certifying user, say, user 108. In one embodiment, a distinct Learning Application Template Developing User Database is configured for receiving, storing, updating and retrieving a plurality of data fields of each learning application template developing user, say, user 110. In one embodiment, a distinct Learning Workshop Organizing User Database is configured for receiving, storing, updating and retrieving a plurality of data fields of each learning workshop organizing user, say, user 116. In one embodiment, a distinct Recruiting User Database is configured for receiving, storing, updating and retrieving a plurality of data fields of each recruiting user, say, recruiting user 120. In one embodiment, a distinct Funding User Database is configured for receiving, storing, updating and retrieving a plurality of data fields of each funding user, say, funding user 122.

**[0043]** In one embodiment, a distinct Institutional Learning Facility Administering User Database is configured for receiving, storing, updating and retrieving a plurality of data fields of each, institutional learning facility administering user, say, user 124. In one embodiment, a distinct Workspace Learning Facility Administering User Database is used to is configured for receiving, storing, updating and retrieving a plurality of data fields of each workspace learning facility administering user, say, user 124. In one embodiment, a distinct Temporary Learning Facility Administering User Database is configured for receiving, storing, updating and retrieving a plurality of data fields of each temporary learning facility administering user, say, user 124. In one embodiment, a distinct Learning Facility Database is configured for receiving, storing, updating and retrieving a plurality of data fields of a plurality of kinds of learning facilities, say, facility 132, as received from a plurality of kinds of learning facility administering users, say, user 124. In one embodiment, a distinct Learning Visits Database is configured for receiving, storing, updating and retrieving a plurality of data fields of each learning visit from the respective learning visit organizing user, say user 114. In some embodiments, the data fields of the databases in the above embodiments are used to determine purchase compatibility using purchase management module 238 and to determine performance compatibility using performance management module 240.

**[0044]** The learning application database 204 is configured for receiving, storing, updating and retrieving all the learning application metadata of all learning applications whose purchase is managed through the module 238. Optionally, all purchase related metadata of the learning application, like number of copies accessed per day, segmented by location, language, learning facility, user device, as well as other learning related purchase analytics metadata that may be generated during the purchase process may be received, stored, and updated by the microlearning purchase management module in the learning application database 204.

**[0045]** In one embodiment, the database 204 is configured for receiving, storing, updating and retrieving all the learning application metadata of all learning applications whose performance is managed through the module 240. Optionally, all performance related metadata of the learning application, like number of copies performed per day, segmented by location, language, learning facility, user device, as well as other learning related performance analytics metadata that may be generated during the performance process may be received, stored, and updated by the microlearning performance management module in the learning application database 204.

**[0046]** A subject database 206 is configured for receiving, storing, updating and retrieving a plurality of data fields of each subject linked or tagged to each learning application 300 in Subject Metadata 312. The subject database 206 provides a categorization system for the learning applications and enables learning application authoring users, like user 104, to categorize learning applications as belonging to one or more subjects by associating them with one or more subjects, such subjects then stored in subject metadata 312 of each authored learning application 300. The subject database 206 also allows users to search for learning applications according to particular subjects using the subjects associated with the learning applications. For example, a tutoring user 112 with a mathematics specialty may search the learning applications using the subject database 206 to identify mathematics learning applications for the tutor to associate his services with.

**[0047]** A tutor database 208 is configured for receiving, storing, updating and retrieving a plurality of data fields of each tutoring user, comprising the tutoring user's name, address, contact details, as well as learning related data fields like learning users to whom microlearning services have or are being provided, performance data and performance review data for the tutoring services, tutoring history outside the modular learning system 144, and remittance history. In some embodiments, the data fields are used to determine purchase compatibility using purchase management module 238 and to determine performance compatibility using performance management module 240.

**[0048]** A learning facilities database 230 is configured for receiving, storing, updating and retrieving a plurality of data fields of a plurality of kinds of learning facilities such as learning facility 132 as received from learning facility administering users 124. In some embodiments, the data fields are used to determine purchase compatibility using purchase management module 238 and to determine performance compatibility using performance management module 240.

**[0049]** A learning tools database 232 is configured for receiving, storing, updating and retrieving a plurality of data fields of each learning tool or material from each learning tools supplying user 118. In some embodiments, the data fields are used to determine purchase compatibility using purchase management module 238 and to determine performance compatibility using performance management module 240.

**[0050]** Each of these databases, such as the tutor database 208, facilities database 230, and learning tools database 232, may also include information relating to purchase and performance compatibility. For example, a tutor in the tutor database may specify the tutor is

only willing to teach students aged 30–40, or a learning facility may indicate it is only willing to allow entry to learning users who are a member of the facility.

**[0051]** A purchase management module 238 is configured for managing the purchase of learning applications and associated application services as a microlearning stack by the learning user 102.

**[0052]** A performance management module 240 is configured for managing the performance of learning applications and associated application services as a microlearning stack by the learning user 102.

**[0053]** A learner recruitment management module 242 is configured for managing the recruitment of learners and associated application services as a microlearning stack by the learning user 102.

**[0054]** In one embodiment, the tutor database, learning facilities database, tools database and other application services databases form a single consolidated application services database in modular learning system 144.

**[0055]** Although the modular learning system 144 is described as being composed of various components like databases and modules, the modular learning system 144 may comprise fewer or more databases, components, and other modules. For example, the modular learning system 144 may include a Learning Application Genre Database, a Locational Learning Facility Price Range Database, a Learning Workshop Database, a Multilingual Dictionary Database, a Concept Tags Database, a Learning Objectives/Outcomes Database, a Micro tutoring Services Database, and a Skill and Ability Tags Database. The modular learning system 144 may also include an Age Compatibility Module, a Learner Ranking Module, a Tutor Ranking Module, a Learner Billing Module, a Tutor Remittance Module, a Profile Management Module, a User Roles Management Module, a Learning Tools Management Module, a Learning Facility Management Module, Metadata Management Module, a Notification Module, a Recruitment Module, a Funding Module, a Map Module, a Learning Application Template Programming Interface Module, an Age Compatibility Module or a Translation Interface Module, with the present disclosure still falling within the scope of various embodiments. In some embodiments, an individual or group may play a plurality of user roles on the modular learning system, (e.g. tutoring user learning new applications as a learning user through another tutoring user, a learning application authoring user translating the authored application or developing the application template), with the present disclosure still falling within the scope of various embodiments.

**[0056]** In various embodiments the modular learning system 144 may be any of a web application, a mobile application, or an embedded module or subsystem of a social networking environment, a learning content management system, a learning management system, a professional networking environment, an electronic commerce system, an electronic payments system, a mobile operating system, a computer based operating system, or of a tablet based operating system, with the present disclosure still falling within the scope of various embodiments.

**[0057]** In one embodiment, a distinct roles management module is configured for managing and authorizing different roles associated with the various users of the modular learning system 144 and in the respective user databases. For example, the roles management module may provide distinct feature tabs and functionalities to each user based on the role associated with him or her. It can be noted that, the roles management module may enable a user to have one or more roles for accessing the modular learning system 144. For example, a tutoring user can avail the functionality and interface tabs of a learning user and also of a translating user if authorized by the modular learning system 144.

**[0058]** In one embodiment, a distinct metadata management module is configured for managing metadata associated with a plurality of specific learning applications, like learning application 300. In one embodiment, the metadata management module is configured for receiving, storing, updating and retrieving various types of metadata associated with each learning application 300 in the learning application database 204. In another embodiment, the metadata management module is configured for receiving and storing updated metadata of a specific learning application 300 in database 204 at regular intervals of time as updated by different users in authorized user roles and retrieving the required metadata when requested by the purchase management module 238 and the performance management module 240 for determining compatibility and performance compatibility of requested microlearning service stack respectively. In yet another embodiment, the metadata management module enables various users of the modular learning platform to update metadata associated with specific learning applications in the learning application database according to their user role.

**[0059]** It is appreciated that, in some embodiments, various databases like 202, 204, 206, 208, 230, and 232, modules 238, 240 and 242 as well as the databases, engines, modules and components of the above embodiments may be stored in the form of machine readable instructions in the memory of the modular learning system 144 and executed by a processor of the modular learning system 144 to perform one or more embodiments disclosed herein. Alternatively, the various databases like 202, 204, 206, 208, 230, and 232, modules 238, 240

and 242 as well as the databases, engines, modules and components of the above embodiments may be implemented in the modular learning system in the form of an apparatus configured to perform one or more embodiments disclosed herein.

**[0060]** FIG. 3A is a block diagram of a learning application 300, according to one embodiment. Each learning application 300 comprises a plurality of kinds of application metadata in addition to the instructional content and associated media for a particular topic or subject. The instructional content and media of each learning application 300 may comprise a specific unit of instruction for a particular portion of knowledge or a skill, and may vary widely in scope. The learning application 300 may be very narrow in scope, such as “treading water” or may be broad in scope, such as “overview of world history”, depending on the authoring process of learning application authoring user 104. The learning application 300 could indicate a theoria (to think, a theory based application using primarily memory, reasoning, logic) performance type or a praxis performance type (to do, a practical performance type or a poeisis performance type). The learning application 300 may comprise metadata indicating associated application services for purchasing or performing the learning application 300 like tutor metadata 336, tools metadata 322 and learning facility metadata 316. In one embodiment, the learning application 300 may be requested for purchase or performance with associated application services as a microlearning service stack, wherein the application services comprise of access to tutoring user 112, access to a learning tool from learning tools database 232 and access to a learning facility from facilities database 230. For example, the media metadata 326 of a learning application 300 provided by learning application authoring user 104 may specify instructions for learning how to swim a breaststroke, but the media metadata 326 does not typically specify individual pools i.e. learning facilities to perform the learning application or tutors to coach and review the performance. Rather, the application services metadata like tutor metadata 336, tools metadata 322 and learning facility metadata 316 indicates tutors, tools, and facilities which the learning user may choose to perform the learning application’s instructions.

**[0061]** The Certification Metadata 302 is configured for receiving, storing, retrieving, displaying and updating certification history as well as live certifications of the learning application 300, including, for example, a certification from educational board 108 and another educational board in another state, present as a certifying user in database 202 or a distinct certifying user database. In some embodiments, the certification metadata is also used to determine purchase compatibility in the microlearning purchase management module 238 through learning application database 204 and to determine performance compatibility in the

microlearning performance management module 240 through learning application database 204.

**[0062]** The Scoring Metrics Metadata 304 is configured for receiving, storing, retrieving, displaying and updating a plurality of metrics for quantitative and qualitative scoring as defined and updated for learning application 300 by learning application authoring user 104. In some embodiments, the quantitative scoring of each metric is conducted during the performance by a dedicated module within the learning application 300 itself, while in other embodiments of a performance, especially a non screen based praxis or poesis performance, the quantitative and optionally, qualitative score for each metric is received through a user device 140 from the learning user 102 and/or the tutoring user 112. In some embodiments, the scoring metrics metadata is also used to determine purchase compatibility in the microlearning purchase management module 238 through learning application database 204 and to determine performance compatibility in the microlearning performance management module 240 through learning application database 204.

**[0063]** The Language Metadata 306 is configured for receiving, storing, retrieving, displaying and updating a plurality of translations of all user viewable application metadata for learning application 300 translated by, for example, learning application translating user 106 into Bengali, comprising of media metadata 326 like instructional text, subtitles to audio and video instructions, and all other linguistic content for the preview, performance and review of learning application 300 by learning user 102 and preview and review of the learning performance by tutoring user 112. In some embodiments, metadata 306 further comprises translations in at least one other language, of performance type metadata 308, duration metadata 310, subject links and tags metadata 312, age level metadata 314, learning facility metadata 316 authoring metadata 318, sequence metadata 320, tool metadata 322, mode metadata 324, medium metadata 328 and job skill metadata 330. In some embodiments, the language metadata is also used to determine purchase compatibility in the microlearning purchase management module 238 through learning application database 204 and to determine performance compatibility in the microlearning performance management module 240 through learning application database 204.

**[0064]** The Performance Type Metadata 308 is configured for receiving, storing, retrieving, displaying and updating the performance type of the learning application 300. For example, the metadata 308 could indicate a theoria (to think, a theory based application using primarily memory, reasoning, logic, like a 'Biomechanics of Swimming' Pop Quiz) performance type or a praxis performance type (to do, a practical performance type like an

‘eight hundred meters Freestyle Swim as per Olympic performance guidelines’ or a poeisis performance type (to make, a creation oriented performance type like a ‘five minute Synchronized Swimming Choreography’), such that the learning user is already aware of the task or performance type before purchasing and performing the learning application 300. In some embodiments, the performance type metadata is also used to determine purchase compatibility in the microlearning purchase management module 238 through learning application database 204 and to determine performance compatibility in the microlearning performance management module 240 through learning application database 204.

**[0065]** The Duration Metadata 310 is configured for receiving, storing, retrieving, displaying and updating the suggested duration of the learning application 300. In some embodiments, the metadata 310 indicates a fixed duration like, fifteen minutes, or thirty minutes, or one hour, while in other embodiments, the metadata indicates a variable duration with, optionally, a predetermined minimum or maximum duration depending on the duration metadata set by the learning application authoring user 104. In some embodiments, the duration metadata is also used to determine purchase compatibility in the microlearning purchase management module 238 through learning application database 204 and to determine performance compatibility in the microlearning performance management module 240 through learning application database 204.

**[0066]** The Subject Metadata 312 is configured for receiving, storing, retrieving, displaying and updating a plurality of subject links and tags attached to the learning application 300 by the learning application authoring user from among the subject links and tags present in the Subject Database 206. In some embodiments, the subject links and tags are attached to specific concepts or terms within the Media Metadata 326. In some embodiments, the subject link/tag metadata is also used to determine purchase compatibility in the microlearning purchase management module 238 through learning application database 204 and to determine performance compatibility in the microlearning performance management module 240 through learning application database 204.

**[0067]** The Age Level Metadata 314 is configured for receiving, storing, retrieving, displaying and updating the suggested age level of the learning user 102 for performance of the learning application 300. In some embodiments, the age level is set as a minimum suggested age say, for example, ten+ by the learning application authoring user 104. In other embodiments, a range of suggested learner ages is set by the learning application authoring user 104. In some embodiments, the age level metadata is also used to determine purchase compatibility in the microlearning purchase management module 238 through learning

application database 204 and to determine performance compatibility in the microlearning performance management module 240 through learning application database 204.

**[0068]** The Learning Facility Metadata 316 is configured for receiving, storing, retrieving, displaying and updating the suggested learning infrastructure required in a learning facility for performance of the learning application 300. In some embodiments, such learning facilities and infrastructure (e.g. Olympic Sized Swimming Pool) required for the performance of the learning application (e.g. eight hundred meters Freestyle to Olympic Guidelines) is received and updated by the learning application authoring user 104 by picking the same from a learning facilities database 230 available on the modular learning system 144. In other embodiments the metadata 316 is received and updated by the administering user 124 of learning facility 132. In some embodiments, the learning facility metadata is also used to determine purchase compatibility in the microlearning purchase management module 238 through learning application database 204 and to determine performance compatibility in the microlearning performance management module 240 through learning application database 204.

**[0069]** The Authoring Metadata 318 is configured for receiving, storing, retrieving, displaying and updating the authoring metadata received by the learning application author 104, including for example the name, signature, contact details, intellectual property disclaimer and other information of the user or user group. In some embodiments, the metadata also includes metadata generated by the modular learning system 144 during the authoring user's editing process, including the version history, tracked changes and time stamps of edits and updates to the learning content application. In some embodiments, the metadata may also include citations to other learning content applications or other learning application authoring users made by the user 104.

**[0070]** The Sequence Metadata 320 is configured for receiving, storing, retrieving, displaying and updating the suggested sequence of performance of the learning application 300 relative to another learning application. The sequence metadata may indicate if the learning application should be performed before, after, instead of, or with another learning application by learning application authoring user 104. The user 104 may wish for any learning user, say 102 to perform an advanced microbiology learning application 300 only after performing a corresponding beginner's microbiology learning application, irrespective of the learning user's age or quality of performance. In other embodiments, wherein the learning application authoring user is not the author of the suggested beginner's application, the user 104 may input a sequence suggesting to the learning user 102 to perform the learning

application before or after a learning application authored by another learning application authoring user. In some embodiments, the sequence metadata is also used to determine purchase compatibility in the microlearning purchase management module 238 through learning application database 204 and to determine performance compatibility in the microlearning performance management module 240 through learning application database 204.

**[0071]** The Tool Metadata 322 is configured for receiving, storing, retrieving, displaying and updating the compatible tools or learning materials to the learning application 300. In some embodiments, the tool compatibility is received from and updated by the learning application authoring user 104 by accessing the tools database 232. In other embodiments, the tool compatibility is received and updated by the learning tools supplying user 118 by accessing the learning application database 204. In still other embodiments, the tool compatibility may be updated by the modular learning system 144. In some embodiments, the tool metadata is used to determine purchase compatibility in the microlearning purchase management module 238 through learning application database 204 and to determine performance compatibility in the microlearning performance management module 240 through learning application database 204. In some embodiments, wherein the learning tool is a peripheral input device which can be connected to the user device 140 during the learning application performance (e.g. Electric Guitar attached to a user device 140 during an 'Introduction to Hard Rock' learning application) the Tool Metadata includes the compatibility to the user device 140. In other embodiments, wherein the learning material is not material to the user device 140, (e.g. Sulphuric Acid during a Chemistry Experiment) the Tool Metadata may not include any additional user device compatibility.

**[0072]** The Mode Metadata 324 is configured for receiving, storing, retrieving, displaying and updating the available modes of performance of the learning application. In some embodiments, the mode metadata is determined by the modes chosen by the learning application authoring user from the learning application template chosen. In various embodiments, the learning application may comprise an individual learner performance mode, a learner plus learner cooperative performance mode, a learner versus learner competitive performance mode, a learner plus tutor cooperative performance mode, a learner versus tutor competitive performance mode, a limited plurality of learners (e.g. four learners) cooperative performance mode, a limited plurality of learners (e.g. four learners) competitive performance mode, a tutor plus limited plurality of learners (e.g. nine learners) cooperative performance mode (a typical classroom mode). Although the Mode Metadata is described as

being composed of various available modes as chosen by the learning application authoring user, various other modes (e.g. a limited plurality of learners vs a limited plurality of learners competitive performance mode) may comprise the Mode Metadata 324 and still fall within the scope of various embodiments. In some embodiments, the various Media Metadata for the preview, performance and review screens for each mode of the same learning application and the sequence of the same (especially wherein the learning application 300 is performed by multiple users from the same user device and, optionally, by viewing the same display device) is received, stored, retrieved, displayed and updated in the Media Metadata 326. In some embodiments, the mode metadata is also used to determine purchase compatibility in the microlearning purchase management module 238 through learning application database 204 and to determine performance compatibility in the microlearning performance management module 240 through learning application database 204.

**[0073]** The Media Metadata 326 is configured for receiving, storing, retrieving, displaying and updating text, image, audio, video, animation, links and other interactive elements of the learning application as received and updated by the learning application authoring user 104 during the publishing and revision of the learning application 300. In other embodiments, the learning application Media Metadata may comprise the theorica, praxis or poesis task or, optionally, plurality of tasks to be completed during the performance, their sequence, and, optionally, the learning outcomes and objectives of the same. In some embodiments, the media metadata is also used to determine purchase compatibility in the microlearning purchase management module 238 through learning application database 204 and to determine performance compatibility in the microlearning performance management module 240 through learning application database 204.

**[0074]** The Medium Metadata 328 is configured for receiving, storing, retrieving, displaying and updating the medium of access to the learning application preview, review and performance screen during the microlearning performance. For example, for a Beginner's Kathak Dancing microlearning Application, in addition to requiring a compatible learning facility and tutoring user, the learning application authoring user 104 or, optionally, modular learning system 144 may require the preview and review screen to be viewable only on a display device connected to a learning console user device or the display device of a computer device but not a mobile device screen to ensure an optimum learning experience. In another case, for a Kathak Quiz microlearning application, the learning application authoring user 104 or, optionally, modular learning system 144 may require the performance screen, preview screen and review screen to be viewable only on a mobile device screen but not on a

display device connected to a learning console user device, or the display device of a computer device. In some embodiments, the medium metadata may further comprise the compatibility to a plurality of software platforms and, optionally, runtime environments as determined by the modular learning system 144. In some embodiments, the medium metadata is also used to determine purchase compatibility in the microlearning purchase management module 238 through learning application database 204 and to determine performance compatibility in the microlearning performance management module 240 through learning application database 204.

**[0075]** The Job Skill Metadata 330 is configured for receiving, storing, retrieving, displaying and updating the skills and abilities tagged to the learning application 300 by the learning application authoring user 104, the recruiting user 120 or, optionally, the modular learning system 144 from a skills and abilities database provided by the modular learning system 144. In some embodiments, the metadata is used by a recruiting user 120 to post the completion of the learning application (optionally, in a controlled testing environment) or group of applications as a minimum requirement for a particular job role to a plurality of potentially employable learning users. In other embodiments, the metadata is used by the recruiting user 120 to post the requirement of completion of the learning application 300 (optionally, in a controlled testing environment) or group of applications as a minimum requirement for a promotion to a higher post in a particular organization, to a plurality of potentially employable learning users. In some embodiments, the job skill metadata is also used to determine purchase compatibility in the microlearning purchase management module 238 through learning application database 204 and to determine performance compatibility in the microlearning performance management module 240 through learning application database 204.

**[0076]** The Error Metadata 332 is configured for receiving, storing, retrieving, displaying and updating the potential errors which can be made by the learning user 102 (e.g. ten potential errors in an auditing microlearning application), as determined by the learning application authoring user 104. In some embodiments, wherein the learning application (e.g. a Karnataka History Quiz) is performed through an input device on a user device 140 itself, the error metadata may be synchronized to each potential input point during the learning application 300 performed through the user device 140 by the learning application authoring user 104. In some embodiments, wherein the learning application (e.g. a Karate kata) 300's error metadata is outside the recordable boundaries of the user device 140, the potential errors may be entered with reference to each instructional step of the performance by the learning

application authoring user 104, such that at the time of the performance, the tutoring user (or, in some modes, the learning user 102 himself, another learning user, or the recruiting user 120) may note errors in each observable step of the performance and confirm the same on user device 140 to generate the score. In other embodiments, wherein the error observed by the observing user (say, tutoring user 112) is not part of the potential errors in the Error Metadata 332 of the application 300, the tutoring user 112 may update such errors to the Errors Metadata, or optionally, send the same to the learning application authoring user 104, to be updated after review. In some embodiments, the error metadata is also used to determine purchase compatibility in the microlearning purchase management module 238 through learning application database 204 and to determine performance compatibility in the microlearning performance management module 240 through learning application database 204.

[0077] The Template Metadata 334 is configured for receiving, storing, retrieving, displaying and updating the default script, formatting and media modules of the learning application template used to author the learning application 300. In some embodiments, wherein a particular sequence and format of the same has been chosen by the learning application authoring user from the options offered in the template developed by the learning application template developing user, the chosen setting may be a part of the Template Metadata 334. In various embodiments, the learning application templates may comprise a quiz, role play, simulation, project, experiment, essay, recital, research paper, race, challenge, problem, game, question, exercise or problem set. In some embodiments, the templates may be for performances conducted and supervised in front of a display device with an input device connected to the user device 140, while in other embodiments the templates may be for previews, reviews and guidelines for performances conducted without the input device, with the user device 140 merely placed next to the performance area or learning station (e.g. for Praxis Tasks in Dance Applications) as a reference point. Although the Template Metadata is described as being composed of various available templates as developed by the learning application template authoring user and chosen by the learning application authoring user, various other templates (e.g. a Swimming Race Template, a Patent Drafting Template) may comprise the Template Metadata 334 and still fall within the scope of various embodiments. In some embodiments, the template metadata is also used to determine purchase compatibility in the microlearning purchase management module 238 through learning application database 204 and to determine performance compatibility in the

microlearning performance management module 240 through learning application database 204.

**[0078]** The Tutor Metadata 336 is configured for receiving, storing, retrieving, displaying and updating the compatibility of tutoring users to learning content application. In some embodiments, the tutoring user compatibility is received from and updated by the tutoring user 112 by updating the tutor database 208 (e.g. a Mathematics Tutoring User whose medium of instruction is Mandarin updating compatibility to a plurality of Mathematics microlearning applications available in Mandarin, in the tutor database 208). In other embodiments, the tutoring user compatibility metadata is received from and updated by the tutoring user 112 by accessing the learning application database 204. In still other embodiments, the tutoring user compatibility metadata may be updated by the modular learning system 144. In some embodiments, the Tutor Metadata is also used to determine purchase compatibility in the microlearning purchase management module 238 through learning application database 204 and to determine performance compatibility in the microlearning performance management module 240 through learning application database 204.

**[0079]** In various embodiments, the metadata of learning application 300 is retrieved, displayed to and updated by a plurality of kinds of users as may be applicable to the kind of metadata and the kind of user. Optionally, in addition to receiving and storing the metadata, the modular learning system 144 may update the learning application metadata as and when generated in the system through a dynamic metadata update module or through a dedicated administering user. In some embodiments, the learning application authoring user 104 may further play the role of the learning application template developing user. In some embodiments, the modular learning system 144 may play the role of the learning application authoring user 104 and, optionally, the role of the learning application template developing user 110 to author and update the media and template metadata of the learning application 300.

**[0080]** In some embodiments, the microlearning purchase management module 238 and microlearning performance management module 240 retrieve some or all of the above metadata associated with the learning application 300 from a learning application database 204 in a repository module of the modular learning system 144.

**[0081]** In some embodiments, the media metadata 326 of the learning application may comprise an electronic textbook, an electronic journal, an instructional video, or an instructional animation. In some embodiments each learning application 300, may be a

distinct mobile application, browser based web application, or a desktop application. In some embodiments, each learning application 300 may be an executable file, a program, add in, macro, plug-in, or other program of instructions associated with a plurality of application programming interfaces of the modular learning system 144.

**[0082]** Although the learning application 300 is described as comprising various metadata and associated data fields stored and updated in learning application database 204, fewer or more metadata and associated data fields (e.g. Application Programming Interface Metadata, Organization versus Organization Social Learning Mode Metadata, University versus University Social Learning Mode Metadata, Testing Metadata, Learning Visits Metadata, Learning Workshops Metadata, Tutorials Metadata) may comprise the Learning Application 300 and associated learning application database 204, with the present disclosure still falling within the scope of various embodiments. In some embodiments, each version of the same learning application 300 with different metadata, for example language metadata, is treated as a distinct learning application in learning application database 204.

**[0083]** In some embodiments, an authorization to update certification metadata 302 of a learning application 300 is limited to a predetermined plurality of certifying users like user 108 and recruiting users like user 120. In some embodiments, an authorization to update scoring metrics metadata 304, performance type metadata 308, age level metadata 314, authoring metadata 318, mode metadata 324, media metadata 326, medium metadata 328, and error metadata 332 of a learning application 300 is limited to a predetermined plurality of learning application authoring users like user 104. In some embodiments, an authorization to update language metadata 306 of a learning application 300 is limited to a predetermined plurality of learning application translating users 106. In some embodiments, an authorization to update duration metadata 310 of a learning application 300 is limited to a predetermined plurality of learning application authoring users like user 104 and learning application template developing users like user 110. In some embodiments, an authorization to update subject link/tag metadata 312 of a learning application 300 is limited to a predetermined plurality of users in any user role. In various embodiments, such authorizations may be set by an administrator of system 144 based on the user role, user profile information and user preferences information of the corresponding users.

**[0084]** In some embodiments, an authorization to update learning facility metadata 316 of a learning application 300 with associated learning facilities is limited to a predetermined plurality of learning facility administering users like user 124. In some embodiments, an authorization to update sequence metadata 320 of a learning application 300 is limited to a

predetermined plurality of learning application authoring users like user 104 and tutoring users like user 112. In some embodiments, an authorization to update tool metadata 322 of a learning application 300 with associated learning tools is limited to a predetermined plurality of tool supplying users like user 118. In some embodiments, an authorization to update job skill metadata 330 of a learning application 300 is limited to a predetermined plurality of recruiting users like user 120. In some embodiments, an authorization to update template metadata 334 of a learning application 300 is limited to a predetermined plurality of learning application authoring users like user 104 and a predetermined plurality of template developing users like user 110. In some embodiments, an authorization to update tutor metadata 336 of a learning application 300 with associated tutoring services is limited to a predetermined plurality of tutoring users like user 112. In some embodiments, an authorization to update an optional learning event metadata of a learning application 300 with associated learning workshops, visits and other learning events is limited to a predetermined plurality of learning workshop organizing users like user 116 and learning visit organizing users like user 114. In some embodiments, the associations of application services to learning applications are enabled automatically by a metadata association module in the system 144. In some embodiments, each learning application 300 is associated with a subset of learning facilities in a learning facilities database 230. In some embodiments, each learning application 300 is further associated with a subset of learning stations of each associated learning facility. In some embodiments, each learning application is associated with a subset of tutors in a tutor database 208. In some embodiments, each learning application is associated with a subset of tools in a learning tools database 232.

**[0085]** FIG. 3B is a block diagram of a learning application 340 according to another example embodiment. The learning application 340 is illustrated to depict metadata of the learning application related to a microlearning service stack. The learning application 340 also illustrates some other performance data used during its performance by a learner. This microlearning service stack may be requested for purchase or performance by learning user 102. In this embodiment, the microlearning service stack includes a learning application 340, a time based tutoring service by a particular tutor in database 208, time based access to a particular learning facility from database 230, and access to a particular tool from database 232. The particular services above may or may not be associated with the corresponding tutor metadata, facilities metadata, and tool metadata of learning application 340 at the time of a request. The learning application 340 includes content data 342 which designates particular content media and content attributes of the learning application 340. The learning application

also includes other metadata as described above, such as tutor metadata 336, learning facility metadata 316, learning tool metadata 322, performance type metadata 308, and scoring metrics metadata 304. As such, the learning application 340 illustrates some aspects of the learning application used for purchase or performance of the learning application 340 by a learner as part of a microlearning service stack, such as content, tutors, facilities, and tools. The learning application 340 may also include any other metadata as described above with reference to FIG. 3A. Any other metadata as described above with reference to FIG. 3A may also be part of the content data 342 of the learning application 340.

**[0086]** The lifecycle of a learning application 300 is now described according to one embodiment. Initially, a learning application template developing user 110 creates a learning application template stored in a distinct template database in a modular learning system 144. Next, the learning application authoring user 104 publishes learning application content stored as media metadata of the learning application 300. In case a template has been chosen for the application 300, the template metadata is stored as well. The tutor metadata, learning facility metadata, learning tool metadata and other optional application services metadata indicating tutoring services, learning facilities, learning tools, and other application service types associated with the learning application 300 are dynamically updated by the corresponding tutoring users, learning facility administrators, tool suppliers and other application service providers. At this point, the learning user may modularly select application services in a microlearning stack to purchase or perform the learning application. Next, the learning user 102 selects the learning application 300 and identifies application services requested for purchase or performance as a consolidated stack. The approval of the purchase or performance request for learning application 300 and particular application services in the microlearning service stack may be determined by the specific metadata of the learning application 300 being associated with corresponding application services, and other specific metadata of the learning application being compatible with the profile information and preferences of the learning user.

**[0087]** FIG. 4 is a block diagram 400 of the learner recruitment management module 242. The skills database module 402 is configured for receiving, storing, retrieving and updating a plurality of job skills associated or tagged to a particular job item's learning applications by accessing the same from the job skill metadata 330 of the learning application, say learning application 300 in the learning application database module 408. In some embodiments, wherein the skills are tagged to a learning application by a recruiting user 120 instead of a learning application authoring user 104, the skills database module is used to receive and

store the job skill metadata once inputted by the recruiting user on the interface generated by the recruitment interface generator 414 and displayed on the user device 140.

**[0088]** The interview performance items module 404 is configured for receiving, storing, retrieving and updating a plurality of interview performance items generated during the recruitment method described herein. In some embodiments, the interview performance is requested by the recruiting user 120, while in other embodiments, the request may be initiated by the learning user once he receives confirmation of the compatibility to minimum learning experience requirements for a particular job item posted by the recruiting user. In some embodiments, the module receives, stores, retrieves and updates the particulars of each unique interview performance including the date, time, recruiting user, learning user, job item and other data items. In some embodiments, wherein the recruiting user 120 requires the learning user 102 to perform a learning application or a set of learning applications wherein the recruiting user acts as a monitoring user during the interview process (e.g. an Audition of ten singing applications comprising twenty learning tasks or Tryout of ten swimming applications comprising ten learning tasks), the interview performance items module includes a trial performance item for each such interview performance, with the trial performance item comprising particulars of the trial performance, like the date, time, place and other logistics of the same. In some embodiments, the performance itself is processed from beginning to end by the microlearning performance management module 240.

**[0089]** The job items module 406 is configured for receiving, storing, retrieving and updating job profile items received from a plurality of recruiting users, like recruiting user 120. Each job item includes the minimum plurality of learning applications to be performed before applying for the job, by the learning user. In addition, each job item includes the particulars of the job profile as inputted by the recruiting user 120 through the recruitment interface generated by generator 414, like the minimum work experience, the pay, the location, the perks and benefits, the skills required as chosen from the skills database 402 by the recruiting user 120. In some embodiments, the job items may be received based on inputs of a human resources administrator conducting internal hiring for promotion or reshuffling of the existing workforce of an organization. In such embodiments, the job item may include the learning applications published for the internal training of the company and only accessible for performance to a subset of learning users as determined by the recruiting user and the corresponding intra organizational learning application authoring user.

**[0090]** The learning application database module 408 is configured for receiving, storing, retrieving and updating a plurality of metadata, purchase analytics and performance analytics

of each learning application associated with a particular job item. In some embodiments, the database may be accessed by the job items module when the recruiting user stores particular learning applications as minimum requirements for a particular job item. For example, for a job role requiring proficiency particularly in a SAP supply chain management software, the recruiting user 120 may require the applicant learning user 102 to have completed 20 praxis learning applications and associated tasks using the SAP software as a learning tool in the presence of a monitoring user, say tutoring user 112 before being applicable for the job item. In such a case, the job items module accesses the learning application database module 408 to store the same against the particular job item. In some embodiments, wherein the recruiting user further specifies minimum scores in particular metrics of each learning application, the database module 408 displays the same to the recruiting user for input choices via the interface generated by generator 414 on a user device 140. In some embodiments, wherein a trial performance is required in the interview process, the database is used to access the appropriate metadata of each application and process the performance using microlearning performance management module 240.

**[0091]** The access control module 410 is configured for granting access to a learning user's performance scores, reviews and other performance data which have been received or generated outside the interview performance, to a compatible recruiting user 120. In some embodiments, wherein the performance data does not match the minimum requirements, and, optionally, the maximum requirements set for the particular job item by the recruiting user 120, the module does not grant access to the learning user's performance data even if the learning user 102 has requested the same. In other embodiments, once a learning user 102 has joined a recruiting user's organization, the module stores access preferences of the learning user 102 and grants access to the recruiting user organization for particular learning applications or groups of learning applications associated with the learning user's learning experience at that particular organization. (e.g. the swimming scores of a learning user learning swimming for recreation may not be accessible to his employing organization, while his training scores in an Ethics Workshop of fifteen learning applications may be accessible to the same recruiting user from the organization). In other embodiments, wherein the learning user is recruited from an organization already in the recruiting user organization database module 412 using the same modular learning system 144, and into another organization in the recruiting user organization database module 412 using the same modular learning system 144, the learning user may grant access to performance scores for a particular set of learning applications performed at the ex employer to the current employer to avoid retraining in the

same applications at the new employer. (e.g. In case of a job item requiring training in the SAP Supply Chain Management software and the SAP Customer Relationship Management software, the learning user may grant access to scores in ten learning applications performed to learn the SAP Supply Chain Management Module at the ex employer, and if the scores are found sufficient, may be required to only perform five applications to learn the SAP Customer Relationship Management software.

**[0092]** The recruiting user organization database module 412 is configured for receiving, storing, updating and retrieving a plurality of data items associated with each authorized individual acting as a recruiting user in a particular organization. In some embodiments, the module is used to receive, store, retrieve and update a recruiting user profile for the organization, for access by the learning user 102. In other embodiments, the module is used to retrieve and associate from time to time the subset of job items and interview performance items associated with the recruiting user, from among the entire plurality of job items and interview performance items received, stored and updated in the modules 402 and 404 by the modular learning system 144. In some embodiments, the module is further used to receive, store, update and retrieve a plurality of data items associated with the all learning users on the modular learning system 144 who are a part of each recruiting user organization, or are in the process of being chosen to be a part of the recruiting user organization.

**[0093]** The recruitment interface generator 414 is configured for generating a plurality of interface items for the recruiting user 120 on a user device 140 to manage the recruitment of learning users on the modular learning system 144, as well as to manage the internal training and promotion process of learning users already present in the recruiting user's organization. In some embodiments, the recruitment interface generator 414 is used to generate a plurality of interface items for the learning user 102 on a user device 140 to manage the exporting, sharing or posting of learning performances data of the learning user to a recruiting user or a preferred plurality of recruiting users, for the purpose of a job interview. Although the learner recruitment management module is described as being composed of various modules, fewer or more modules (e.g. Minimum Scoring Metrics Compatibility Module, Learning Performance Items Portability Module, Resume Parser, Professional Networking System Profile Importer Module) could comprise the module, with the present invention still falling within the scope of various embodiments.

**[0094]** FIG. 5 is a flow diagram 500 of the method for a recruiting user to manage recruitments in a modular learning system environment. At step 502, the modular learning system 144 receives a learning user recruitment request from a recruiting user, say, recruiting

user 120 through an interface generated by the recruitment interface generator 414 on a user device 140. At step 504, the recruiting user 120 inputs particulars of a job item, like the language preferred, the work experience preferred, the location of work, the pay, and other such items normally present in a job posting. In some embodiments, the particulars may be used to filter learning users who can even access the job item, by correlating and filtering the same from the learning user database 202.

**[0095]** At step 506, the recruiting user 120 inputs the choices of learning applications required to have been performed by any learning user, say learning user 102 before applying for the job item. (e.g. twenty five particular learning applications to be performed in microbiology, fifty particular applications to be performed in evolutionary biology in addition to five hundred particular applications of mathematics, and four hundred particular applications of chemistry, before applying for a particular job role). In some embodiments, in cases wherein repeated practice displays the quality or other personal traits of the learning user, the recruiting user 120 may input the minimum number of times the learning application or set of learning applications need to have been performed (e.g. in Acrobatic practice) before a learning user may apply for the job item. At step 508, the recruiting user 120 may input specific minimum scores in each scoring metric or aggregate scores for each learning application and, optionally, for each application in a set of applications to have been scored by a learning user 102 before applying for the job item, to restrict applicants even if the learning users have performed all the learning applications. In some embodiments, wherein the recruiting user does not wish to perform this granular filtering of learning users at this stage of the recruitment process, the method may proceed directly to step 510, with the present invention still falling within the scope of various embodiments.

**[0096]** At step 510, the interview performance items module 404 determines the preferences for an interview performance of a learning application or a set of learning applications required to be performed by the learning user or set of learning users in the interview with the recruiting user 120, based on preferences inputted by the recruiting user 120 through the interface generated by recruitment interface generator 414 on a user device 140. In some embodiments, wherein an interview performance is not required, and the recruiting user 120 simply wishes to schedule a non performance related interview with a particular learning user or set of learning users, an optional interview scheduling module in the learner recruitment management module 242 may be used to schedule the same in the learning user database 202 and the recruiting user organization database module 412, with the

next input from the recruiting user directly being the updation of the job status of the learning user or set of learning users, after the non performance related interview, at step 528.

**[0097]** At step 512, the recruitment interface generator 414 generates an interview confirmation item with the particulars of the interview and interview performance for the job item and displays the same to the learning user 102 on a user device 140.

**[0098]** At step 514, the interview performance items module 404 requests the microlearning performance management module 240 to determine the availability of the appropriate tools, learning infrastructure, monitoring user and, in some embodiments, the compatible controlled learning facility for the trial performance. At step 516, the microlearning performance management module 240 determines the immediate service availability of application services for the trial performance of the learning application or set of learning applications, during the interview process. In some embodiments, the recruiting user 120 may authorize a particular user or particular plurality of users as monitoring users during the trial performance. In some embodiments, the monitoring user may be a random tutoring user, while in other embodiments the monitoring user may be the recruiting user's organization's placement or hiring agency. In other embodiments, the recruiting user 120 may authorize the manager or senior under whom the learning user would work, as the monitoring user during the trial performance.

**[0099]** At step 518, the trial performance request is granted by the microlearning performance management module 240. At step 520, the microlearning performance management module 240 processes the application's preview, performance and review based on the learning application's metadata and, in some embodiments, the learning user's inputs on a user device 140. At step 522, the learning application's review screen is displayed on the recruiting user 120's device user device 140. At step 524, the microlearning performance management module 240 determines whether the learning performance for the performed application or, optionally, set of applications can be manually reviewed by a monitoring user, in this case the recruiting user 120. In the case of some applications, wherein the performance of the application occurs on the learning user's user device 140 itself (e.g. a SAP SCM Quiz), the learning application review screen may be directly displayed with the scores generated for the application based on the inputs received by the learning user, on the recruiting user 120's user device 140.

**[0100]** At step 526, when a manual review is possible or required (e.g. a Sales Call Roleplay), the interview performance items module 404 receives the scores inputted for each scoring metric and the review of the application performance from the recruiting user through

an the application review screen generated by the microlearning performance management module 240 on any of the user devices 140. In some embodiments, the recruiting user may review the performances of multiple learning users as is customary in an interview process, before confirming recruitment to a particular learning user. In such embodiments, the above scores and reviews data is received or generated for each unique interview, and stored as a unique interview performance data item, and the recruiting user proceeds to confirmation of a learning user after completing the interview related steps for each interviewing learning user, with the present invention still falling within the scope of various embodiments.

**[0101]** At step 528, the recruitment interface generator 414 receives a confirmation or denial input from the recruiting user 120 for the learning user 102 and the corresponding job item on a user device 140. At step 530, the recruitment interface generator 414 determines the appropriate interface item to display on the learning user's user device 140. At step 532, when the learning user has not been successfully recruited, the recruitment interface generator 414 generates a job denied interface item and displays it against the job item for the concerned learning user 102 on a user device 140. At step 534, when the learning user has been successfully recruited, the recruitment interface generator 414 generates a job confirmation interface item and displays it against the job item for the concerned learning user 102 on a user device 140. At step 536, the learning user 102 is added to the recruiting user 120's organization database in database module 412. In some embodiments, the access control module 410 is used to manage authorization by the recruited learning user to the recruiting user to access the performance history of the recruited learning user in learning applications performed in a personal capacity, in academic life or even in the previous employer's training program, in case they use the same modular learning system 144. In such embodiments, the learner performance items are also stored against the corresponding recruiting user in the recruiting user organization database module 412.

**[0102]** Although the method for a recruiting user to manage recruitments of learning users in a modular learning system environment is described as being composed of various steps, fewer or more steps (e.g. Filter Compatible Learning Users By Preferred Identity Items, Determine Minimum Application Practice Preferences From Recruiting User) may comprise the method, with the present invention still falling within the scope of various embodiments.

**[0103]** FIG. 6 is a flow diagram 600 of the method for a learning user to post performance data to a recruiting user in a modular learning system environment. At step 602, the modular learning system 144 receives a learning performance export or sharing request

from the learning user, say learning user 102, to be posted to a recruiting user, say recruiting user 120. In some embodiments, the learning user may export, share or post performance scores or reviews of a plurality of learning applications. In some embodiments, the learning user 102 may export, share or post performance scores or reviews of one or a plurality of learning applications to a plurality of recruiting users for one or a plurality of job items.

**[0104]** At step 604, the request is accessed by the access control module 410 to determine the minimum compatibility of the learning user's performance items for the chosen job item. At step 606, the access control module 410 determines the compatibility of the learning user's performance items by accessing the job items module 406, the learning user database 202, as well as the learning application database module 408. In case the learning user does not meet or exceed all of the minimum performance requirements of the job item as inputted by the recruiting user 120, the access control module 410 does not display the learning user's performance items and, optionally, other identity items to the recruiting user for the job item.

**[0105]** At step 608, when the performance items of the learning user for the job item meet the minimum performance requirements set for the application or set of applications by the recruiting user 120, the recruitment interface generator 414 displays the learning user 102's performance items including the scores and reviews generated or received for the performances of the learning applications relevant to the particular job item. In some embodiments, if the learning user 102 so authorizes, the access control module 410 grants access to other learning user identity items of the learning user including profile items, name, address and other personal particulars, as well as work experience and resume as inputted or imported by the learning user into the modular learning system 144 and stored and accessed through the learning user database 202.

**[0106]** Although the method for a learning user to post performance data to a recruiting user in a modular learning system environment is described as being composed of various steps, fewer or more steps (e.g. Display Learner Identity Items to Recruiting User) may comprise the method, with the present invention still falling within the scope of various embodiments.

#### COMPUTING MACHINE ARCHITECTURE

**[0107]** FIG. 7 is a block diagram illustrating modules of an example machine suitable for use as a modular learning system 144, in which any of the embodiments disclosed herein may be performed, according to one embodiment. This example machine is able to read

instructions from a machine-readable medium and execute them in a processor (or controller).

**[0108]** Specifically, FIG. 7 shows a diagrammatic representation of a machine in the example form of a computer system 700 within which instructions 724 (e.g., software) for causing the machine to perform any one or more of the methodologies discussed herein may be executed. In alternative embodiments, the machine operates as a standalone device or may be connected (e.g., networked) to other machines. In a networked deployment, the machine may operate in the capacity of a server machine or a client machine in a server-client network environment, or as a peer machine in a peer-to-peer (or distributed) network environment.

**[0109]** The machine may be a server computer, a client computer, a personal computer (PC), a tablet PC, a set-top box (STB), a personal digital assistant (PDA), a cellular telephone, a smartphone, a web appliance, a network router, switch or bridge, or any machine capable of executing instructions 724 (sequential or otherwise) that specify actions to be taken by that machine. Further, while only a single machine is illustrated, the term “machine” shall also be taken to include any collection of machines that individually or jointly execute instructions 724 to perform any one or more of the methodologies discussed herein.

**[0110]** The example computer system 700 includes a processor 702 (e.g., a central processing unit (CPU), a graphics processing unit (GPU), a digital signal processor (DSP), one or more application specific integrated circuits (ASICs), one or more radio-frequency integrated circuits (RFICs), or any combination of these), a main memory 704, and a static memory 706, which are configured to communicate with each other via a bus 708. The computer system 700 may further include a graphics display unit 710 (e.g., a plasma display panel (PDP), a liquid crystal display (LCD), a projector, or a cathode ray tube (CRT)). The computer system 700 may also include alphanumeric input device 712 (e.g., a keyboard), a cursor control device 714 (e.g., a mouse, a trackball, a joystick, a motion sensor, or other pointing instrument), a storage unit 716, a signal generation device 718 (e.g., a speaker), and a network interface device 720, which also are configured to communicate via the bus 708.

**[0111]** The storage unit 716 includes a machine readable medium 722 on which is stored instructions 724 (e.g., software) embodying any one or more of the methodologies or functions described herein. The instructions 724 (e.g., software) may also reside, completely or at least partially, within the main memory 704 or within the processor 702 (e.g., within a processor’s cache memory) during execution thereof by the computer system 700, the main memory 704 and the processor 702 also constituting machine-readable media. The

instructions 724 (e.g., software) may be transmitted or received over a network 142 via the network interface device 720.

**[0112]** While machine readable medium 722 is shown in an example embodiment to be a single medium, the term “machine-readable medium” should be taken to include a single medium or multiple media (e.g., a centralized or distributed database, or associated caches and servers) able to store instructions (e.g., instructions 724). The term “machine-readable medium” shall also be taken to include any medium that is capable of storing instructions (e.g., instructions 724) for execution by the machine and that cause the machine to perform any one or more of the methodologies disclosed herein. The term “machine-readable medium” includes, but not be limited to, data repositories in the form of solid-state memories, optical media, and magnetic media.

**[0113]** The modular learning system 144 may be one or more servers in which one or more methods disclosed herein are performed. The processor 702 may be a microprocessor, a state machine, an application specific integrated circuit, a field programmable gate array, etc. (e.g., Intel<sup>®</sup> Pentium<sup>®</sup> processor). The main memory 704 may be a dynamic random access memory and/or a primary memory of the modular learning system 144. The static memory 706 may be a hard drive, a flash drive, and/or other memory information associated with the modular learning system 144.

**[0114]** The bus 708 may be an interconnection between various circuits and/or structures of the modular learning system 144. The video display 710 may provide graphical representation of information on the modular learning system 144. The alphanumeric input device 712 may be a keypad, keyboard and/or any other input device. The cursor control device 714 may be a pointing device such as a mouse.

**[0115]** The storage unit 716 may be a hard drive, a storage system, and/or other longer term storage subsystem. The signal generation device 718 may be a bios and/or a functional operating system of the modular learning system 144. The network interface device 720 may be a device that may perform interface functions such as code conversion, protocol conversion and/or buffering required for communication to and from a network (e.g., the network 142 of FIG 1). The machine readable medium 722 may provide instructions 724 on which any of the methods disclosed herein may be performed. The instructions 724 may provide source code and/or data code to the processor 702 to enable any one/or more operations disclosed herein. For example, the modular learning system 144 may be stored in the form of instructions 724 on a storage medium such as the main memory 704 and/or the machine readable medium 722 such as compact disk.

[0116] In one embodiment, a non-transitory computer-readable storage medium having a program executable by a computing device (e.g. the modular learning system 144) causes the computing device to perform method steps illustrated in FIG 5A, 5B and FIG 6.

#### ADDITIONAL CONFIGURATION CONSIDERATIONS

[0117] As such, the modular learning system enables recruiting users to identify learning users for recruitment and learning users are able to identify job parameters for being recruited for learning users. For example, an engineering firm may use a recruiting user to seek learners for hiring who perform well on learning application for a particular computer programming language, for example the Java programming language, and seek to recruit learning users who performed well on learning applications for Java. For example, the recruitment interface generator 414 can be configured to identify those learners that have completed tutoring sessions with an engineer associated with a computer company to select a new hire for the company. The modular learning system 144 can then further process the retrieved subset to identify those learners that have acquired operating system certifications from certified learning applications. performed well with other users outside of the computer company. In this manner, the recruiting user is able to quickly and efficiently identify those learning users with the specific skill sets required for the job and learning users who already have some relationship with the company.

[0118] In addition to selecting users to hire based on the learning applications, recruiting users may provide feedback to the modular learning system 144 indicating the success or failure of the hire. For example, after hiring a user who has completed five learning applications in Java, the recruiting user may provide a response to the modular learning system 144 three and six months after hire to indicate whether the hire is performing well at the company of the recruiting user. Using the success and failure information provided by the recruiting user, the modular learning system can provide statistics of learning applications, tutors, and other learning services that are statistically more likely to provide learning users that are likely to be successful hires by the recruiting user, based on the success or failure of hiring other learning users.

[0119] Throughout this specification, plural instances may implement modules, operations, or structures described as a single instance. Although individual operations of one or more methods are illustrated and described as separate operations, one or more of the individual operations may be performed concurrently, and nothing requires that the operations be performed in the order illustrated. Structures and functionality presented as

separate modules in example configurations may be implemented as a combined structure or module. Similarly, structures and functionality presented as a single module may be implemented as separate modules. These and other variations, modifications, additions, and improvements fall within the scope of the subject matter herein.

**[0120]** Certain embodiments are described herein as including functionality implemented in computing logic or a number of modules, components, or mechanisms, for example, as illustrated in FIGS. 2, 4, and 5. Modules may constitute either software modules (e.g., code embodied on a machine-readable medium or in a transmission signal) or hardware modules. A hardware module is tangible unit capable of performing certain operations and may be configured or arranged in a certain manner. In example embodiments, one or more computer systems (e.g., a standalone, client or server computer system) or one or more hardware modules of a computer system (e.g., a processor or a group of processors) may be configured by software (e.g., an application or application portion) as a hardware module that operates to perform certain operations as described herein.

**[0121]** In various embodiments, a hardware module may be implemented mechanically or electronically. For example, a hardware module may comprise dedicated circuitry or logic that is permanently configured (e.g., as a special-purpose processor, such as a field programmable gate array (FPGA) or an application-specific integrated circuit (ASIC)) to perform certain operations. A hardware module may also comprise programmable logic or circuitry (e.g., as encompassed within a general-purpose processor or other programmable processor) that is temporarily configured by software to perform certain operations. It will be appreciated that the decision to implement a hardware module mechanically, in dedicated and permanently configured circuitry, or in temporarily configured circuitry (e.g., configured by software) may be driven by cost and time considerations.

**[0122]** The various operations of example methods described herein may be performed, at least partially, by one or more processors, e.g., processor 702, that are temporarily configured (e.g., by software) or permanently configured to perform the relevant operations. Whether temporarily or permanently configured, such processors may constitute processor-implemented modules that operate to perform one or more operations or functions. The modules referred to herein may, in some example embodiments, comprise processor-implemented modules.

**[0123]** The one or more processors may also operate to support performance of the relevant operations in a “cloud computing” environment or as a “software as a service” (SaaS). For example, at least some of the operations may be performed by a group of

computers (as examples of machines including processors), these operations being accessible via a network (e.g., the Internet) and via one or more appropriate interfaces (e.g., application program interfaces (APIs)).

**[0124]** In another embodiment, the microlearning purchase and performance interface provided by the modular learning system 144 can be accessed over a local area network, intranet or virtual private network accessible to a limited plurality of user devices at a preschool, school, college, university, educational board, professional standards authority, coaching class, a company, HR department, training department or at a training organization through a user device.

**[0125]** In another embodiment, the microlearning purchase and performance interface provided by the modular learning system 144 can be accessed over a wide area network, General Packet Radio Service network, an Enhanced Data for Global Evolution network, a 3G telecommunications network, a 4G LTE telecommunications network or other telecommunications network through a user device.

**[0126]** The performance of certain of the operations may be distributed among the one or more processors, not only residing within a single machine, but deployed across a number of machines. In some example embodiments, the one or more processors or processor-implemented modules may be located in a single geographic location (e.g., within a home environment, an office environment, or a server farm). In other example embodiments, the one or more processors or processor-implemented modules may be distributed across a number of geographic locations.

**[0127]** Some portions of this specification are presented in terms of algorithms or symbolic representations of operations on data stored as bits or binary digital signals within a machine memory (e.g., a computer memory). These algorithms or symbolic representations are examples of techniques used by those of ordinary skill in the data processing arts to convey the substance of their work to others skilled in the art. As used herein, an “algorithm” is a self-consistent sequence of operations or similar processing leading to a desired result. In this context, algorithms and operations involve physical manipulation of physical quantities. Typically, but not necessarily, such quantities may take the form of electrical, magnetic, or optical signals capable of being stored, accessed, transferred, combined, compared, or otherwise manipulated by a machine. It is convenient at times, principally for reasons of common usage, to refer to such signals using words such as “data,” “content,” “bits,” “values,” “elements,” “symbols,” “characters,” “terms,” “numbers,” “numerals,” or the like.

These words, however, are merely convenient labels and are to be associated with appropriate physical quantities.

**[0128]** Although the present embodiments have been described with reference to specific example embodiments, it will be evident that various modifications and changes may be made to these embodiments without departing from the broader spirit and scope of the various embodiments. For example, the various devices, modules, databases, etc. described herein may be enabled and operated using hardware circuitry (e.g., complementary metal-oxide-semiconductor (CMOS) based logic circuitry), firmware, software and/or any combination of hardware, firmware, and/or software (e.g., embodied in a machine readable medium).

**[0129]** Unless specifically stated otherwise, discussions herein using words such as “processing,” “computing,” “calculating,” “determining,” “presenting,” “displaying,” or the like may refer to actions or processes of a machine (e.g., a computer) that manipulates or transforms data represented as physical (e.g., electronic, magnetic, or optical) quantities within one or more memories (e.g., volatile memory, non-volatile memory, or a combination thereof), registers, or other machine modules that receive, store, transmit, or display information.

**[0130]** As used herein any reference to “one embodiment” or “an embodiment” means that a particular element, feature, structure, or characteristic described in connection with the embodiment is included in at least one embodiment. The appearances of the phrase “in one embodiment” in various places in the specification are not necessarily all referring to the same embodiment.

**[0131]** Some embodiments may be described using the expression “coupled” and “connected” along with their derivatives. For example, some embodiments may be described using the term “coupled” to indicate that two or more elements are in direct physical or electrical contact. The term “coupled,” however, may also mean that two or more elements are not in direct contact with each other, but yet still co-operate or interact with each other. The embodiments are not limited in this context.

**[0132]** As used herein, the terms “comprises,” “comprising,” “includes,” “including,” “has,” “having” or any other variation thereof, are intended to cover a non-exclusive inclusion. For example, a process, method, article, or apparatus that comprises a list of elements is not necessarily limited to only those elements but may include other elements not expressly listed or inherent to such process, method, article, or apparatus. Further, unless expressly stated to the contrary, “or” refers to an inclusive or and not to an exclusive or. For

example, a condition A or B is satisfied by any one of the following: A is true (or present) and B is false (or not present), A is false (or not present) and B is true (or present), and both A and B are true (or present).

**[0133]** In addition, use of the “a” or “an” are employed to describe elements and modules of the embodiments herein. This is done merely for convenience and to give a general sense of the invention. This description should be read to include one or at least one and the singular also includes the plural unless it is obvious that it is meant otherwise.

**[0134]** According to the embodiments described in FIG 1 through 6, various methods and electric structures may be embodied using transistors, logic gates, and electrical circuits (e.g., Application Specific Integrated Circuitry and/or in Digital Signal Processor circuitry). For example, the purchase management module 238, performance management module 240 and other modules of Figures 1 to 6 may be enabled using a purchase management circuit, a performance management circuit, and other circuits using one or more of the technologies described herein. In addition, it will be appreciated that the various operations, processes, and methods disclosed herein may be embodied in a machine-readable medium and/or a machine accessible medium compatible with a data processing system (e.g., a server) and may be performed in any order. Accordingly, the specification and drawings are to be regarded in an illustrative rather than a restrictive sense.

**[0135]** Upon reading this disclosure, those of skill in the art will appreciate still additional alternative structural and functional designs for a system and a process for managing the purchase and performance of learning applications and associated application services in a microlearning stack through the disclosed principles herein. Thus, while particular embodiments and applications have been illustrated and described, it is to be understood that the disclosed embodiments are not limited to the precise construction and modules disclosed herein. Various modifications, changes and variations, which will be apparent to those skilled in the art, may be made in the arrangement, operation and details of the method and apparatus disclosed herein without departing from the spirit and scope defined in the appended claims.

## WHAT IS CLAIMED IS:

1. A computer-implemented method for managing recruitments in a modular learning system, the method comprising:
  - receiving a learning user recruitment request from a user device operated by a recruiting user;
  - determining, from the learning user recruitment request, a minimum number of learning applications for the learning user recruitment request;
  - determining, from the learning user recruitment request, a minimum metrics score for each learning application in the learning user recruitment request;
  - providing, to a learning user qualifying for the minimum number of learning applications and the minimum metrics score, an interview confirmation to the learning user;
  - determining a trial performance availability for a trial performance of a learning application;
  - processing a trial performance of the learning application;
  - receiving recruiter review data for the trial performance;
  - determining a recruitment of learning user; and
  - responsive to a determination the learning user is recruited by the recruiting user, adding the learning user to an organization database associated with a recruiting user organization database.
2. The computer-implemented method of claim 1, wherein the learning user recruitment request specifies job skills metadata.
3. The computer-implemented method of claim 1, wherein the minimum number of learning applications are learning applications published by the recruiting user.
4. The computer-implemented method of claim 1, wherein the learning user provides access to view performance metrics of learning applications to the recruiting user.
5. The computer-implemented method of claim 4, wherein the performance metrics of the learning applications viewable by the recruiting user are applications specified by the recruiting user related to the recruitment request.

6. A non-transitory computer-readable storage medium having tangibly embodied thereon a program of instructions executable by a processor for executing steps comprising:
  - receiving a learning user recruitment request from a user device operated by a recruiting user;
  - determining, from the learning user recruitment request, a minimum number of learning applications for the learning user recruitment request;
  - determining, from the learning user recruitment request, a minimum metrics score for each learning application in the learning user recruitment request;
  - providing, to a learning user qualifying for the minimum number of learning applications and the minimum metrics score, an interview confirmation to the learning user;
  - determining a trial performance availability for a trial performance of a learning application;
  - processing a trial performance of the learning application;;
  - receiving recruiter review data for the trial performance;
  - determining a recruitment of learning user; and
  - responsive to a determination the learning user is recruited by the recruiting user, adding the learning user to an organization database associated with a recruiting user organization database.
7. The computer-readable storage medium of claim 6, wherein the learning user recruitment request specifies job skills metadata.
8. The computer-readable storage medium of claim 6, wherein the minimum number of learning applications are learning applications published by the recruiting user.
9. The computer-readable storage medium of claim 6, wherein the learning user provides access to view performance metrics of learning applications to the recruiting user.
10. The computer-readable storage medium of claim 9, wherein the performance metrics of the learning applications viewable by the recruiting user are applications specified by the recruiting user related to the recruitment request.

11. An apparatus comprising:
  - a network interface configured for managing recruitments in a modular learning system;
  - a processor coupled to the network interface;
  - a memory coupled to the processor, wherein the memory includes instructions for execution on the processor comprising steps for:
    - receiving a learning user recruitment request from a user device operated by a recruiting user;
    - determining, from the learning user recruitment request, a minimum number of learning applications for the learning user recruitment request;
    - determining, from the learning user recruitment request, a minimum metrics score for each learning application in the learning user recruitment request;
    - providing, to a learning user qualifying for the minimum number of learning applications and the minimum metrics score, an interview confirmation to the learning user;
    - determining a trial performance availability for a trial performance of a learning application;
    - processing a trial performance of the learning application;;
    - receiving recruiter review data for the trial performance;
    - determining a recruitment of learning user; and
    - responsive to a determination the learning user is recruited by the recruiting user, adding the learning user to an organization database associated with a recruiting user organization database.
12. The apparatus of claim 11, wherein the learning user recruitment request specifies job skills metadata.
13. The apparatus of claim 11, wherein the minimum number of learning applications are learning applications published by the recruiting user.
14. The apparatus of claim 11, wherein the learning user provides access to view performance metrics of learning applications to the recruiting user.
15. The apparatus of claim 14, wherein the performance metrics of the learning applications viewable by the recruiting user are applications specified by the recruiting user related to the recruitment request.

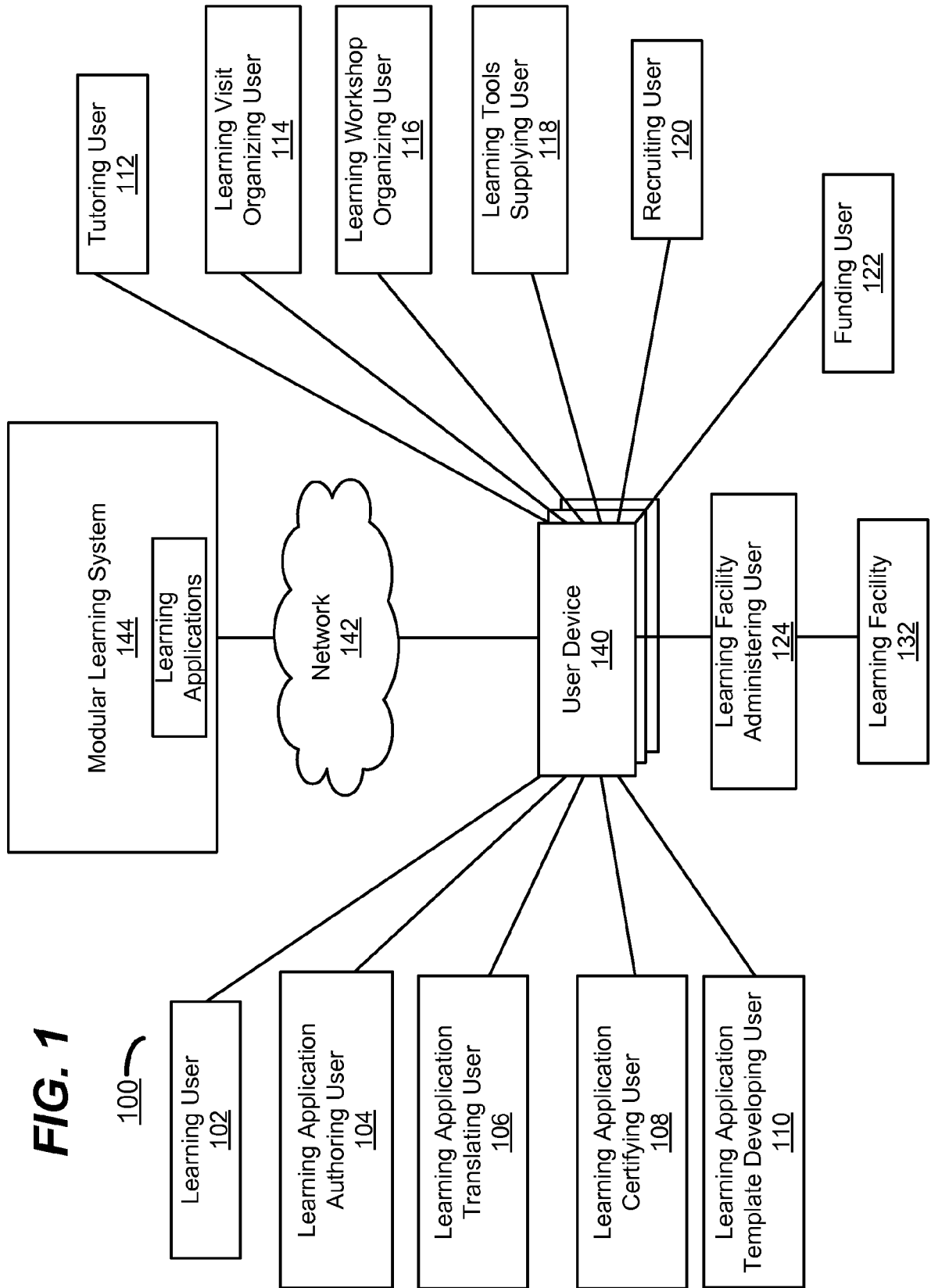

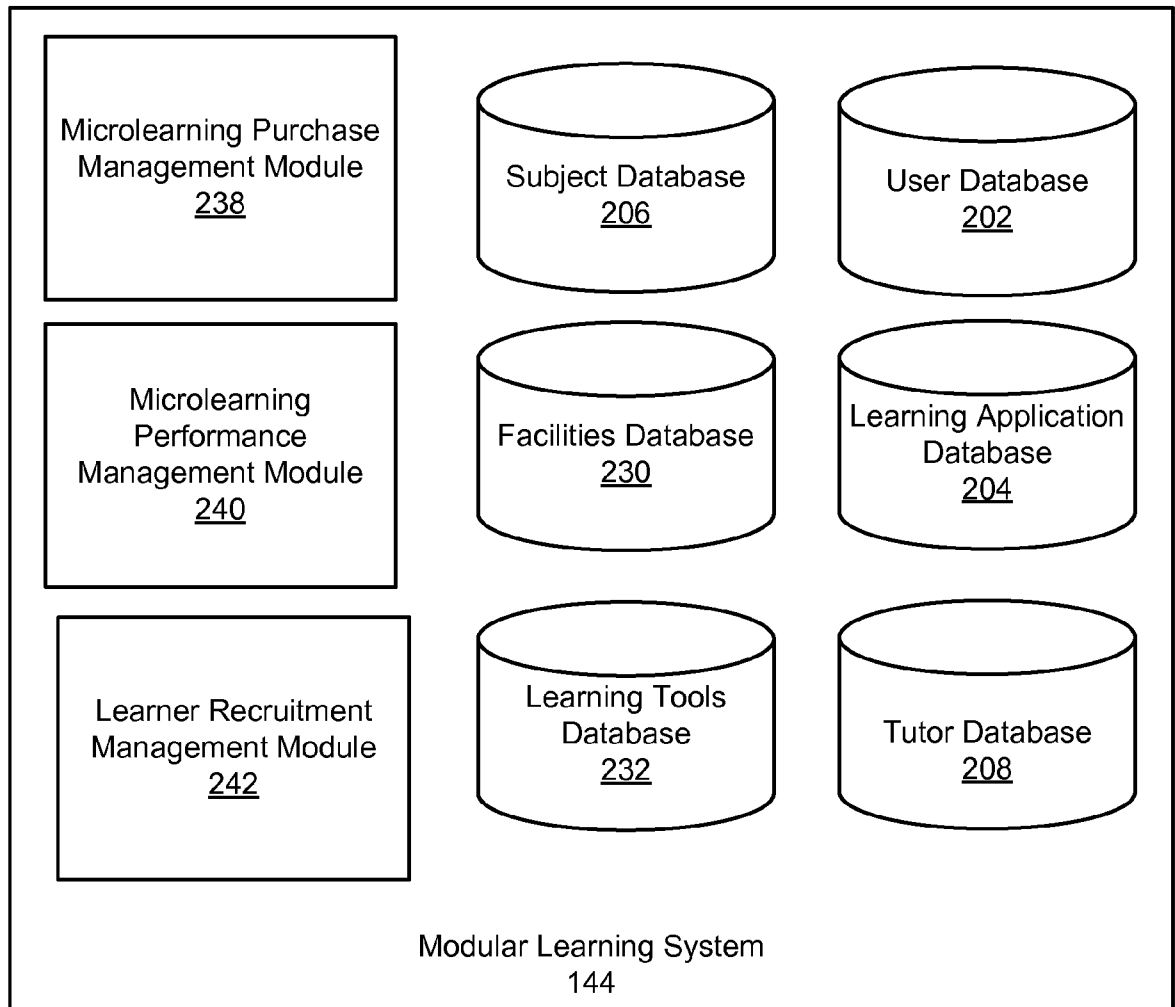
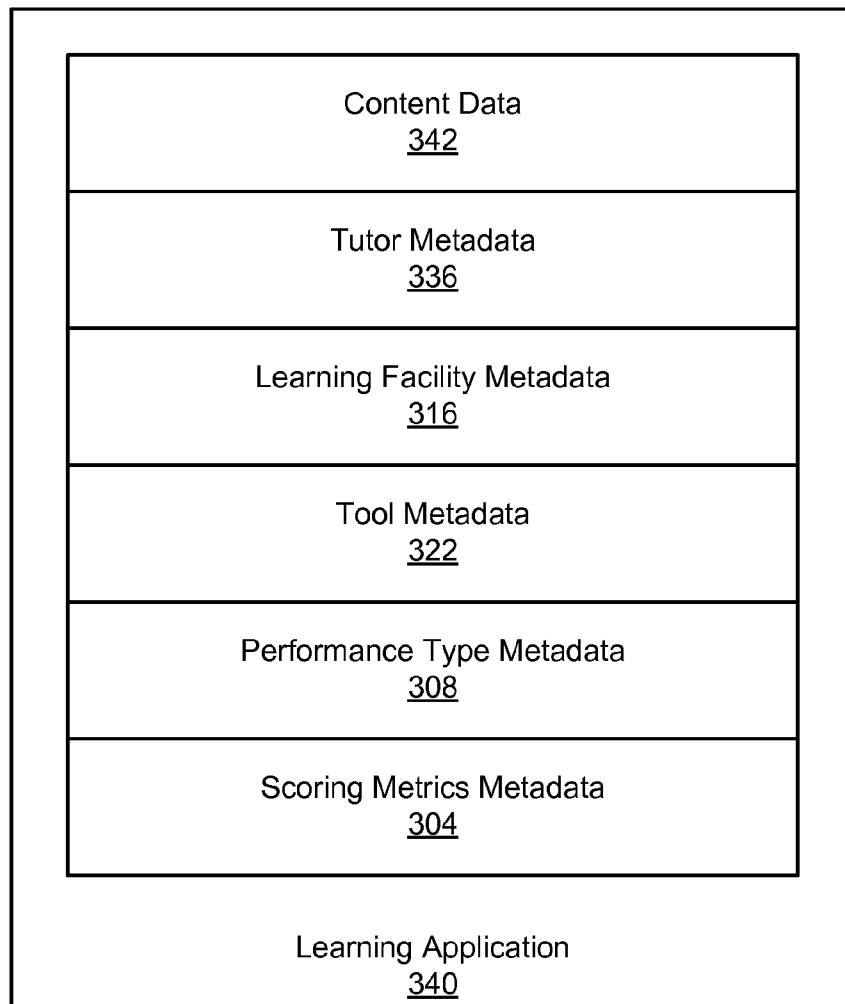

**FIG. 2**

Certification Metadata <u>302</u>	Scoring Metrics Metadata <u>304</u>
Language Metadata <u>306</u>	Performance Type Metadata <u>308</u>
Duration Metadata <u>310</u>	Subject Link/Tag Metadata <u>312</u>
Age Level Metadata <u>314</u>	Learning Facility Metadata <u>316</u>
Authoring Metadata <u>318</u>	Sequence Metadata <u>320</u>
Tool Metadata <u>322</u>	Mode Metadata <u>324</u>
Media Metadata <u>326</u>	Medium Metadata <u>328</u>
Job Skill Metadata <u>330</u>	Error Metadata <u>332</u>
Template Metadata <u>334</u>	Tutor Metadata <u>336</u>

Learning Application  
300

**FIG. 3A**

**FIG. 3B**

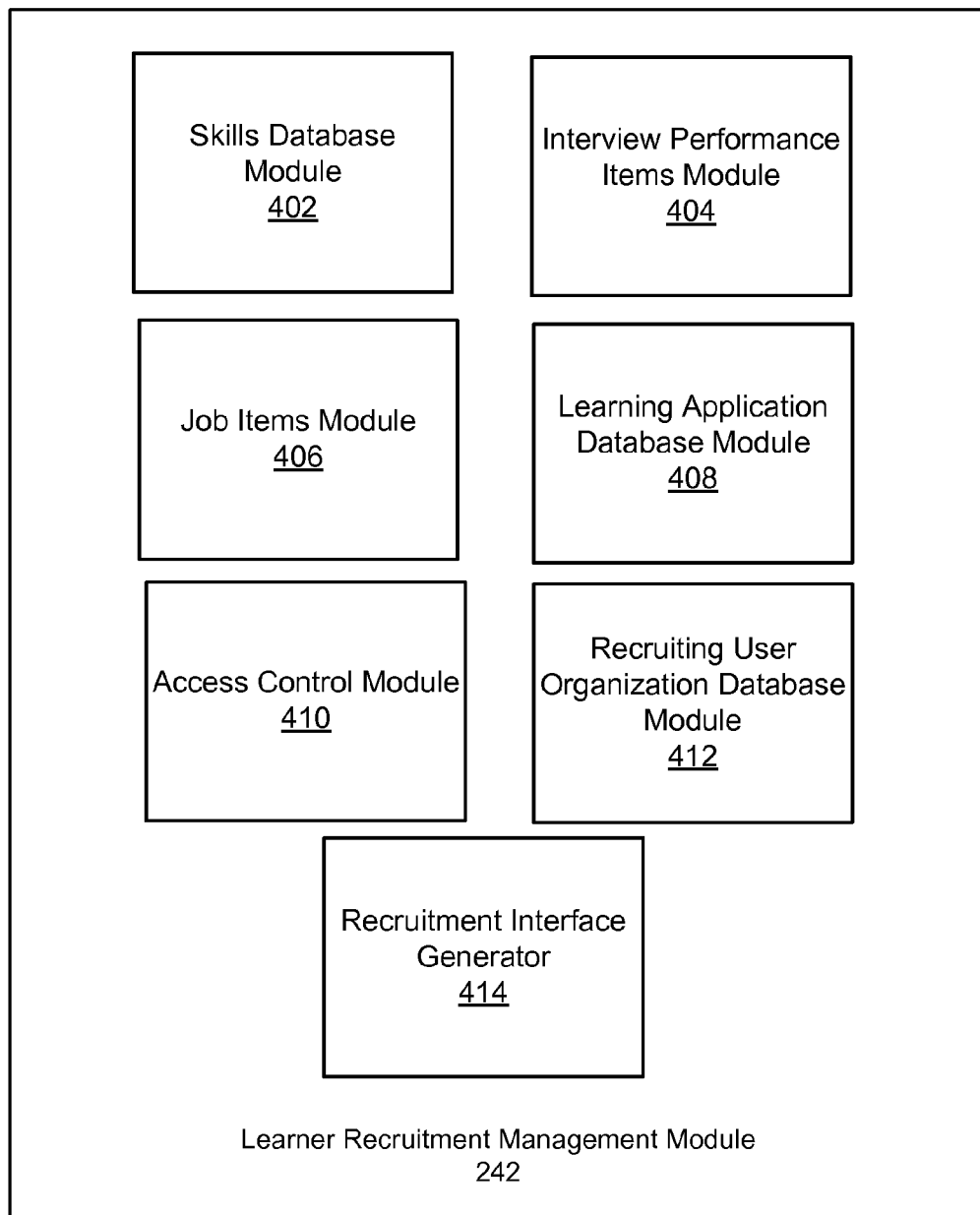

**FIG. 4**

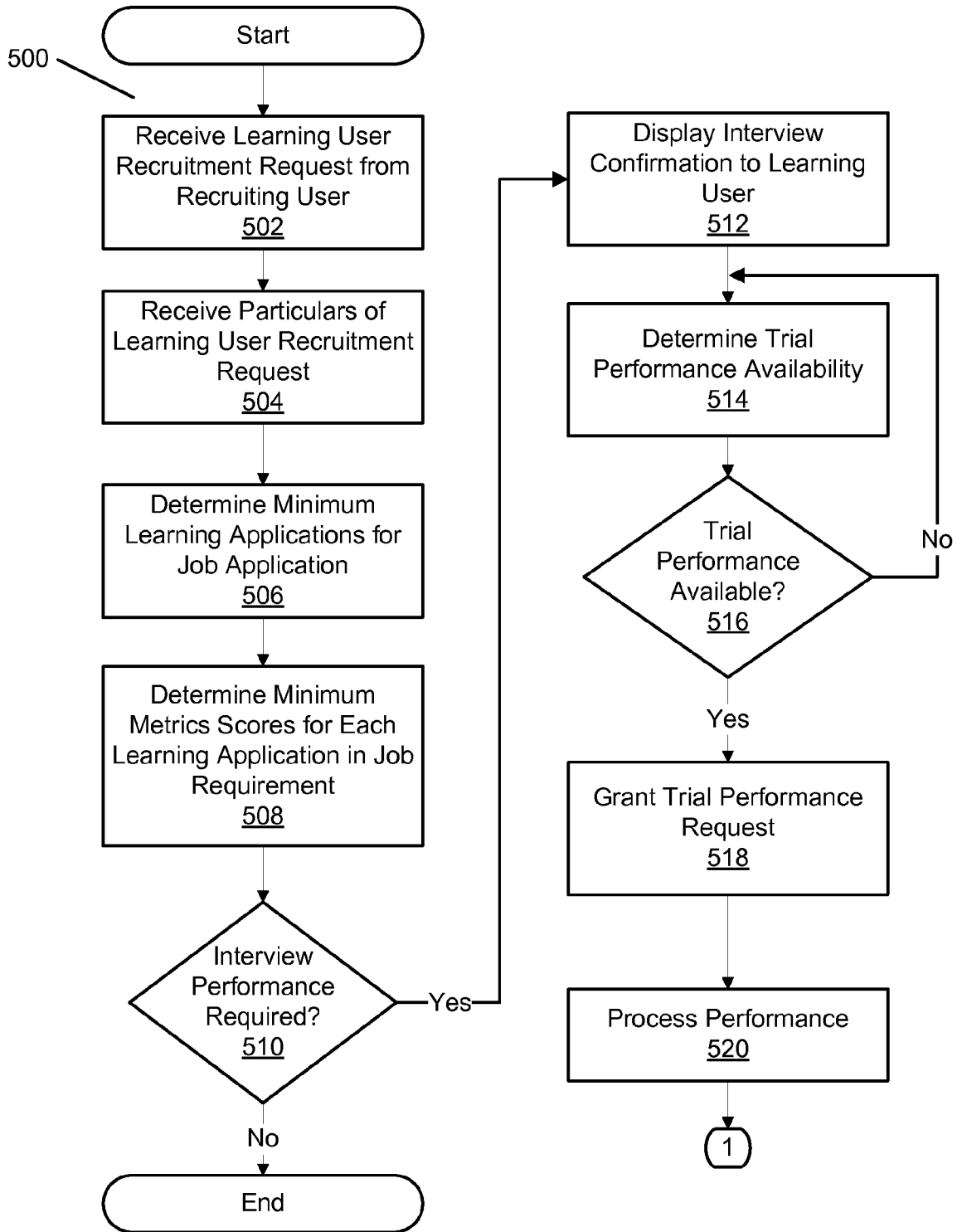

**FIG. 5A**

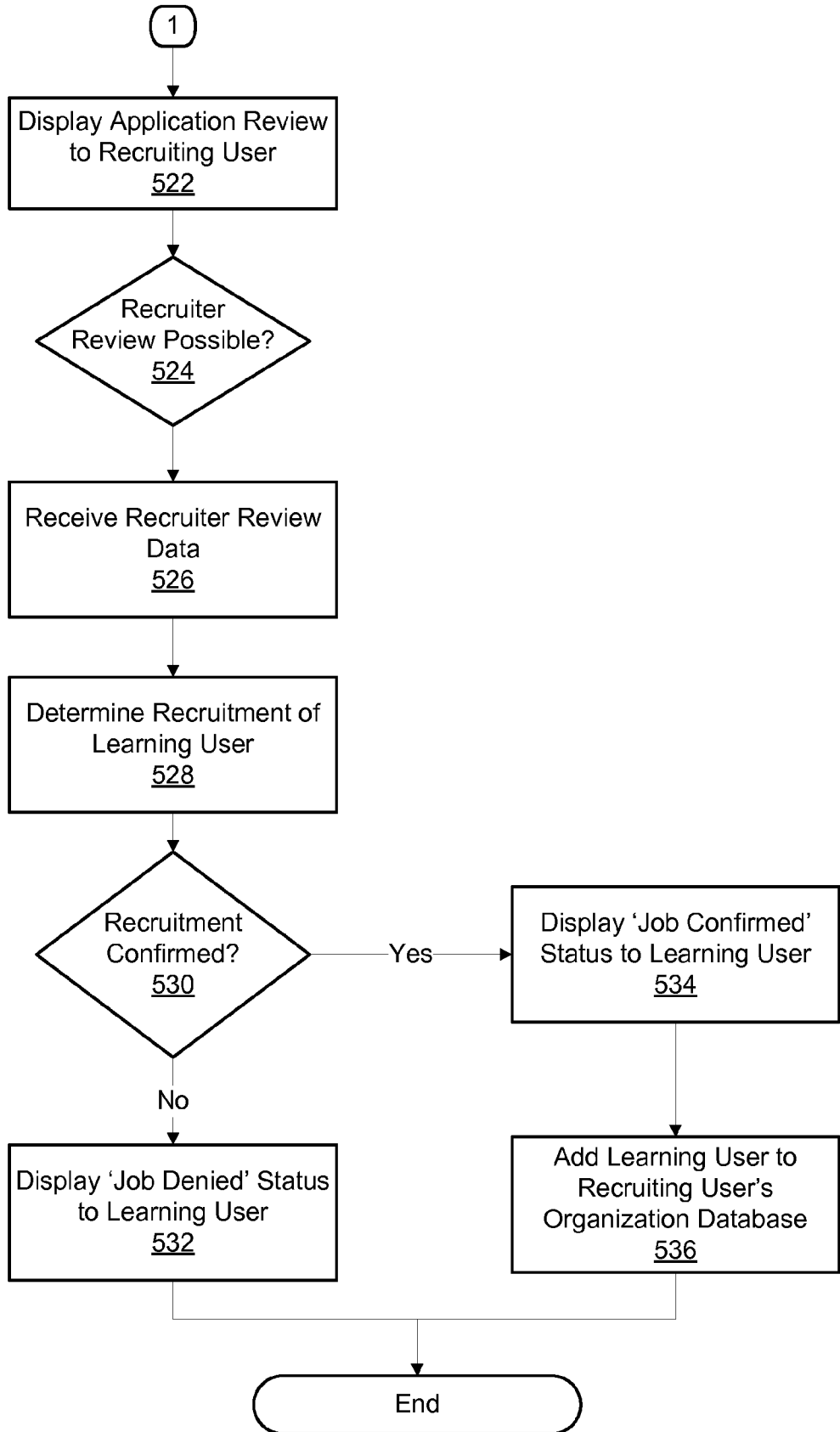

**FIG. 5B**

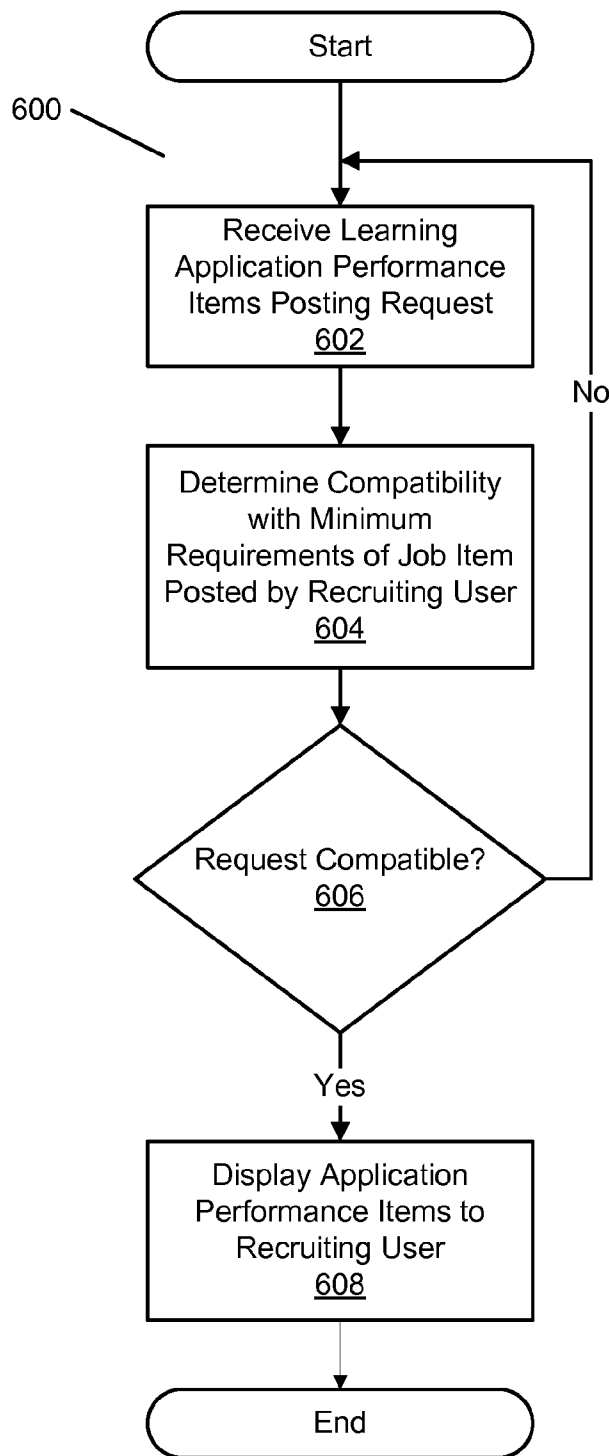

**FIG. 6**

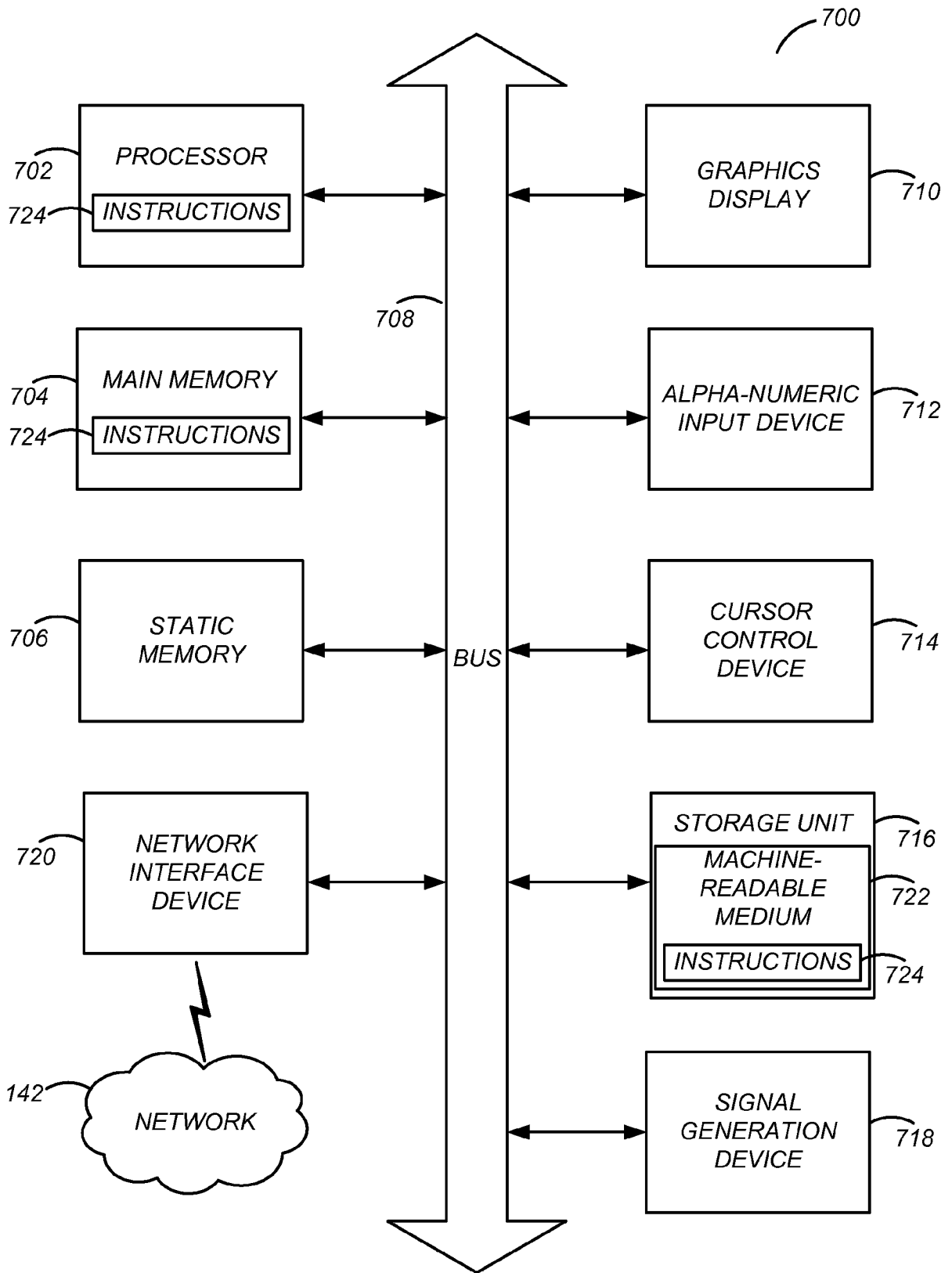

**FIG. 7**

INTERNATIONAL SEARCH REPORT

International application No.  
PCT/US2012/054940

<p><b>A. CLASSIFICATION OF SUBJECT MATTER</b>                  IPC(8) - G09B 3/00 (2012.01)                  USPC - 434/322                  According to International Patent Classification (IPC) or to both national classification and IPC</p>																	
<p><b>B. FIELDS SEARCHED</b>                  Minimum documentation searched (classification system followed by classification symbols)                  IPC(8) - G09B 3/00, 5/00, 7/00 (2012.01)                  USPC - 434/322, 350, 365                  Documentation searched other than minimum documentation to the extent that such documents are included in the fields searched                  Electronic data base consulted during the international search (name of data base and, where practicable, search terms used)                  PatBase, Elsevier Inc Engineering Village: Compendex, Inspec, NTIS</p>																	
<p><b>C. DOCUMENTS CONSIDERED TO BE RELEVANT</b></p> <table border="1"> <thead> <tr> <th>Category*</th> <th>Citation of document, with indication, where appropriate, of the relevant passages</th> <th>Relevant to claim No.</th> </tr> </thead> <tbody> <tr> <td>Y</td> <td>US 2008/0050715 A1 (GOLCZEWSKI et al) 28 February 2008 (28.02.2008) entire document</td> <td>1-15</td> </tr> <tr> <td>Y</td> <td>US 2003/0093346 A1 (WEBER) 15 May 2003 (15.05.2003) entire document</td> <td>1-15</td> </tr> <tr> <td>Y</td> <td>US 2011/0098156 A1 (NG et al) 28 April 2011 (28.04.2011) entire document</td> <td>1-15</td> </tr> <tr> <td>Y</td> <td>US 6,537,072 B2 (KANEVSKY et al) 25 March 2003 (25.03.2003) entire document</td> <td>2, 7, 12</td> </tr> </tbody> </table>			Category*	Citation of document, with indication, where appropriate, of the relevant passages	Relevant to claim No.	Y	US 2008/0050715 A1 (GOLCZEWSKI et al) 28 February 2008 (28.02.2008) entire document	1-15	Y	US 2003/0093346 A1 (WEBER) 15 May 2003 (15.05.2003) entire document	1-15	Y	US 2011/0098156 A1 (NG et al) 28 April 2011 (28.04.2011) entire document	1-15	Y	US 6,537,072 B2 (KANEVSKY et al) 25 March 2003 (25.03.2003) entire document	2, 7, 12
Category*	Citation of document, with indication, where appropriate, of the relevant passages	Relevant to claim No.															
Y	US 2008/0050715 A1 (GOLCZEWSKI et al) 28 February 2008 (28.02.2008) entire document	1-15															
Y	US 2003/0093346 A1 (WEBER) 15 May 2003 (15.05.2003) entire document	1-15															
Y	US 2011/0098156 A1 (NG et al) 28 April 2011 (28.04.2011) entire document	1-15															
Y	US 6,537,072 B2 (KANEVSKY et al) 25 March 2003 (25.03.2003) entire document	2, 7, 12															
<p><input type="checkbox"/> Further documents are listed in the continuation of Box C. <input type="checkbox"/></p>																	
<p>* Special categories of cited documents:</p> <table border="0"> <tr> <td>"A" document defining the general state of the art which is not considered to be of particular relevance</td> <td>"T" later document published after the international filing date or priority date and not in conflict with the application but cited to understand the principle or theory underlying the invention</td> </tr> <tr> <td>"E" earlier application or patent but published on or after the international filing date</td> <td>"X" document of particular relevance; the claimed invention cannot be considered novel or cannot be considered to involve an inventive step when the document is taken alone</td> </tr> <tr> <td>"L" document which may throw doubts on priority claim(s) or which is cited to establish the publication date of another citation or other special reason (as specified)</td> <td>"Y" document of particular relevance; the claimed invention cannot be considered to involve an inventive step when the document is combined with one or more other such documents, such combination being obvious to a person skilled in the art</td> </tr> <tr> <td>"O" document referring to an oral disclosure, use, exhibition or other means</td> <td>"&amp;" document member of the same patent family</td> </tr> <tr> <td>"P" document published prior to the international filing date but later than the priority date claimed</td> <td></td> </tr> </table>			"A" document defining the general state of the art which is not considered to be of particular relevance	"T" later document published after the international filing date or priority date and not in conflict with the application but cited to understand the principle or theory underlying the invention	"E" earlier application or patent but published on or after the international filing date	"X" document of particular relevance; the claimed invention cannot be considered novel or cannot be considered to involve an inventive step when the document is taken alone	"L" document which may throw doubts on priority claim(s) or which is cited to establish the publication date of another citation or other special reason (as specified)	"Y" document of particular relevance; the claimed invention cannot be considered to involve an inventive step when the document is combined with one or more other such documents, such combination being obvious to a person skilled in the art	"O" document referring to an oral disclosure, use, exhibition or other means	"&" document member of the same patent family	"P" document published prior to the international filing date but later than the priority date claimed						
"A" document defining the general state of the art which is not considered to be of particular relevance	"T" later document published after the international filing date or priority date and not in conflict with the application but cited to understand the principle or theory underlying the invention																
"E" earlier application or patent but published on or after the international filing date	"X" document of particular relevance; the claimed invention cannot be considered novel or cannot be considered to involve an inventive step when the document is taken alone																
"L" document which may throw doubts on priority claim(s) or which is cited to establish the publication date of another citation or other special reason (as specified)	"Y" document of particular relevance; the claimed invention cannot be considered to involve an inventive step when the document is combined with one or more other such documents, such combination being obvious to a person skilled in the art																
"O" document referring to an oral disclosure, use, exhibition or other means	"&" document member of the same patent family																
"P" document published prior to the international filing date but later than the priority date claimed																	
<p>Date of the actual completion of the international search 21 November 2012</p>		<p>Date of mailing of the international search report <b>10 DEC 2012</b></p>															
<p>Name and mailing address of the ISA/US                  Mail Stop PCT, Attn: ISA/US, Commissioner for Patents                  P.O. Box 1450, Alexandria, Virginia 22313-1450                  Facsimile No. 571-273-3201</p>		<p>Authorized officer:                  Blaine R. Copenheaver                  PCT Helpdesk: 571-272-4300                  PCT OSP: 571-272-7774</p>															