

Aug. 19, 1930.

R. J. BURNS

1,773,343

EDGE SCOURING MACHINE

Filed Jan. 22, 1924

Fig. 1.

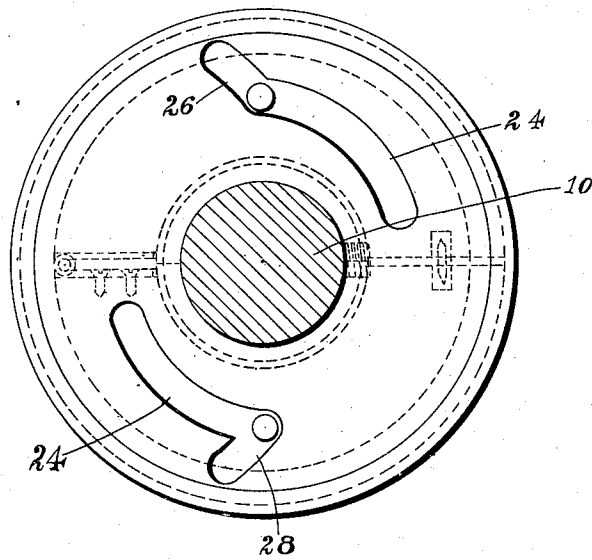

Fig. 3.

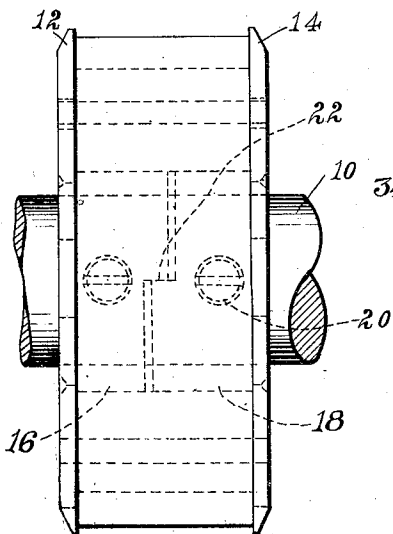
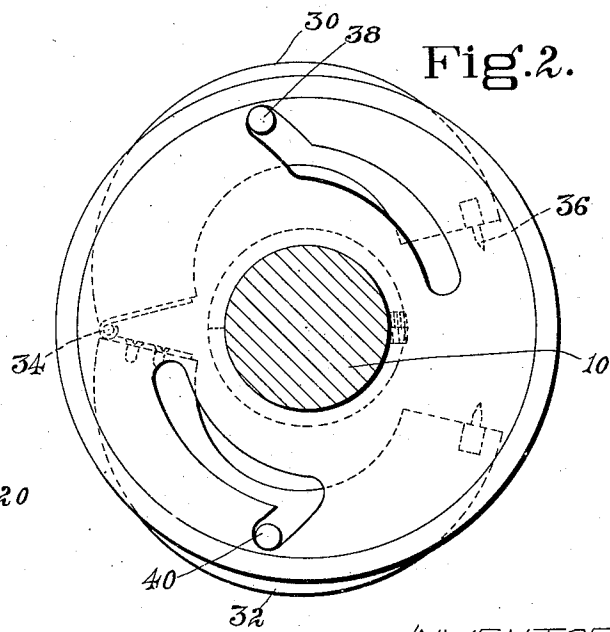

Fig. 2.



INVENTOR-

Robert J. Burns
By his Attorney,
Nelson M. Howard

UNITED STATES PATENT OFFICE

ROBERT J. BURNS, OF ST. LOUIS, MISSOURI, ASSIGNOR TO UNITED SHOE MACHINERY CORPORATION, OF PATERSON, NEW JERSEY, A CORPORATION OF NEW JERSEY

EDGE-SCOURING MACHINE

Application filed January 22, 1924. Serial No. 687,711.

This invention relates to finishing rolls and is illustrated as embodied in a scouring roll of the split type provided with retaining flanges. One form of scouring roll which is well known to the trade is illustrated in Patent No. 1,326,495 issued Dec. 30, 1919, upon the application of Charles E. Graham. In this form a two-part hub having broad flanges is mounted directly upon the shaft and forms a retaining means for the split body portion, this body portion comprising two halves of an annulus hinged together at one edge and provided with transverse pins travelling in cam slots in the retaining flanges for holding the two halves of the body portion in closed position. Commonly the split body portion is made of wood and is covered with a thick layer of felt around which a strip of abrasive cloth may be wound and maintained in position until it is so much worn that it needs renewal.

As the operator rotates the body portion with respect to the flanges in order to open up the two sections of the body portions to allow the removal and replacement of the strip of abrasive cloth, the transverse pins in the body portions travel along the cam slots and, releasing the sections of the body portions, positively cause them to open or to close, according to the direction in which the body portion is rotated relatively to the flanges. In order to prevent binding of the pins in the cam slots, and to insure that each pin and slot assembly does its proper share of the work of opening and closing the hinged body and maintaining it closed, the flanges must at all times occupy a predetermined fixed position relative to each other whereby the degree of opening or closing of the body as determined by either one of the pin and slot assemblies will at all times be equal to the degree of opening or closing as determined by the other pin and slot assembly. The arrangement must be such that the opening and closing of the body portions will not displace either of the flanges upon the shaft or affect their relative position. In case body portions of different widths are used, it is necessary for the operator to unclamp one of the flanges from the shaft and move it laterally thereon to allow the removal of the body

portion of one width and the insertion of another body portion. When the operator moves the flange back into coacting relation with the pins of the body portion, it is essential that it shall be replaced so that the cam slots in said flange shall be brought into exactly opposite relation to the cam slots of the other flange.

One object of the present invention is to devise a commercially satisfactory scouring roll provided with means for ensuring the correct alinement of the cam slots in the two flanges.

In the illustrated embodiment of the invention, the shaft engaging portions of the hub members are extended inwardly for a substantial distance and provided with overlapping portions jointed along a line parallel with the axis whereby the correct alinement of the slots in the flanges of said hub members may be maintained easily whenever the operator finds it necessary to replace the body member or substitute one of different width.

In the drawings,

Fig. 1 is a side elevation illustrating the members of the body portion in closed position but not locked;

Fig. 2 is a side elevation showing the members of the body portion in open position; and

Fig. 3 is a front elevation of the arrangement shown in Fig. 1.

The device is intended to be mounted upon a shaft, such as that shown at 10, and comprises a two-part hub consisting of flanges 12 and 14 and hub portions 16 and 18. Set screws 20 in the hub portions are used for retaining the hubs in their desired relation on the shaft, and it will be seen that these hub portions are provided with overlapping joints, as at 22, whereby they may be adjusted to different lateral positions but maintained in a predetermined relation circumferentially of the shaft. Each of the flanges is provided with corresponding slots comprising a cam portion 24 and end portions 26 and 28. The body member, which fills the spaces between the flanges of the hubs and is retained in position by the flanges abutting respectively the end faces of the body member, comprises two halves 30 and 32 of an

annulus which are hinged together at 34 eccentrically of the axis of the body member and are provided with projecting pins 36 for the retention of the strip of abrasive cloth in a manner well understood in the art. Pins 38 and 40 are mounted transversely of the two halves of the annulus and extend from the end faces thereof, being designed to enter the slots in the flanges of the hub members, each pin and the cam portion of the slot which it enters being regarded as a pair of co-operating cam elements. When it is desired to open the body portion to renew the abrasive strip the body member is rotated relative to the flanges and the pins are brought opposite end sections 26 and 28 in the slots. These end sections, it will be seen from an inspection of Fig. 2, are substantially concentric with the center of hinge 34 so that they may allow the opening of the body portion with the greatest facility. After the ends of the strip have been engaged upon the pins 36 the two halves of the body portion will be closed and a reverse relative rotation between the body portion and the hub members effected to cause the pins 38 and 40 to travel along the cam portions 24, whereby the body portions will be wedged tightly in position as the pins approach the center of the shaft and the scouring roll will be ready for use. The closed slots are effective to prevent accidental detachment of the body portions from the roll in case they become unlocked and tend to fly apart due to centrifugal force. This arrangement is not claimed herein, however, as it is claimed in United States Letters Patent No. 1,593,685, granted July 27, 1926, upon the application of Ernest Ashton, Serial No. 700,967, filed March 21, 1924, and assigned to the same assignee.

Because of variations in width of the various body portions which are supplied and because of the variations in similar body portions, it is not feasible to make the hub sections 16 and 18 integral. Furthermore, such an integral construction would not allow the ready replacement of the body portions should breakage occur because of the necessity for entering the pins 38 and 40 in the slots in the flanges of the hub members.

The problem from a practical standpoint is further complicated by the considerable width of the body portions employed and the fact that if the hub portions 16 and 18 were to be made integral with the flanges 12 and 14 a very considerable amount of metal would have to be removed, thereby rendering the device unduly expensive. It has been found, however, that the arrangement may be constructed at relatively small expense by utilizing metal tubing for the hub portions 16 and 18 and arc-welding sections of this tubing to flange members which have been cut out of flat plates. By such an arrangement the necessary strength is obtained and

the expense of production maintained within the desired limits.

Since the hub members are not integral, it is desirable to provide some means of insuring that they be assembled on the shaft 10 in a fixed position circumferentially relative to each other, this position being predetermined by the fact that the degree of opening or closing of the roll body determined by a pair of cooperating cam elements on one side of the roll body shall be equal to the degree of opening or closing determined by the pair on the opposite side of the roll body. Since the pins 38 on either side of the hinged member 30 are circumferentially fixed with relation to each other, it is therefore desirable that the cam portions 24 of the slots on the flanges 12 and 14 respectively be fixed circumferentially with relation to each other, and to this end the overlapping joints 22 are provided on each hub member. The set screws 20 are for the purpose of securing the hub members to the shaft 10 in the relative circumferential position indicated by the overlapping joints 22.

Having thus described my invention, what I claim as new and desire to secure by Letters Patent of the United States is:—

1. In a scouring roll having hinged body members provided with laterally extending pins, hub members provided with slots cooperating with said pins, and coacting means upon said hub members constructed and arranged to insure the correct relation of said hub members when they are adjusted in position upon the shaft irrespective of variations in the widths of the body members used.

2. In a scouring roll comprising hinged body members provided with laterally extending locking pins, hub members having flanges with cam slots designed to co-operate with and secure in position said body members, said hub members being provided with coacting normally contacting surfaces substantially parallel to the axis of rotation arranged to determine the correct relation of said hub members on a shaft, and means for retaining said hub members in position upon the shaft.

3. A scouring roll comprising a roll body divided into a pair of members hinged together eccentrically of the axis of the body and having a cam element upon each of the end faces of one of said hinged members, a pair of hub members each adapted to abut longitudinally one end of said roll body and each carrying a cam element adapted to co-operate with the cam element on the adjacent face of said one hinged member, each cooperating pair of said cam elements being constructed and arranged to cause opening and closing movements of said roll body upon relative rotation between said body and said hub members, interengaging members carried by the hub members constructed and ar-

ranged to position the hub members relatively to each other with the cam members at one end face in the same relation to each other as the cam members at the other end face, said interengaging members at all times
5 positively preventing relative circumferential movement of the hub members, and means for securing said hub members to a shaft in said relative position.

4. A scouring roll comprising a roll body
10 divided into a pair of members hinged together eccentrically of the axis of the body and having a cam element upon each of the end faces of one of said hinged members, a
15 pair of hub members each adapted to abut longitudinally one end of said roll body and each carrying a cam element adapted to cooperate with the cam element on the adjacent
20 face of said hinged member, each co-operating pair of said cam elements being constructed and arranged to cause opening and closing movements of said hinged body upon
25 relative rotation between said body and said hub members, co-acting means on said hub members for insuring a predetermined relative circumferential position of said hub
members whereby the degree of opening or closing of the hinged member determined
30 by one pair of co-operating cam elements will at all times be equal to the degree of such opening or closing determined by the other pair of co-operating cam elements, and means for securing said hub members to a shaft in said relative position.

35 In testimony whereof I have signed my name to this specification.

ROBT. J. BURNS.

40

45

50

55

60

65