



(72) VAN DEN BRINK, ALFRED, NL

(71) AUTOGASTECHNIEK HOLLAND B.V., NL

(51) Int.Cl.⁶ F16K 31/06

(30) 1998/06/09 (1009355) NL

(30) 1998/12/31 (98204495.0) EP

(54) **SOUPAPE DE DOSAGE ET SYSTEME D'ALIMENTATION EN
CARBURANT EQUIPE DE CETTE SOUPAPE**

(54) **METERING VALVE AND FUEL SUPPLY SYSTEM EQUIPPED
THEREWITH**

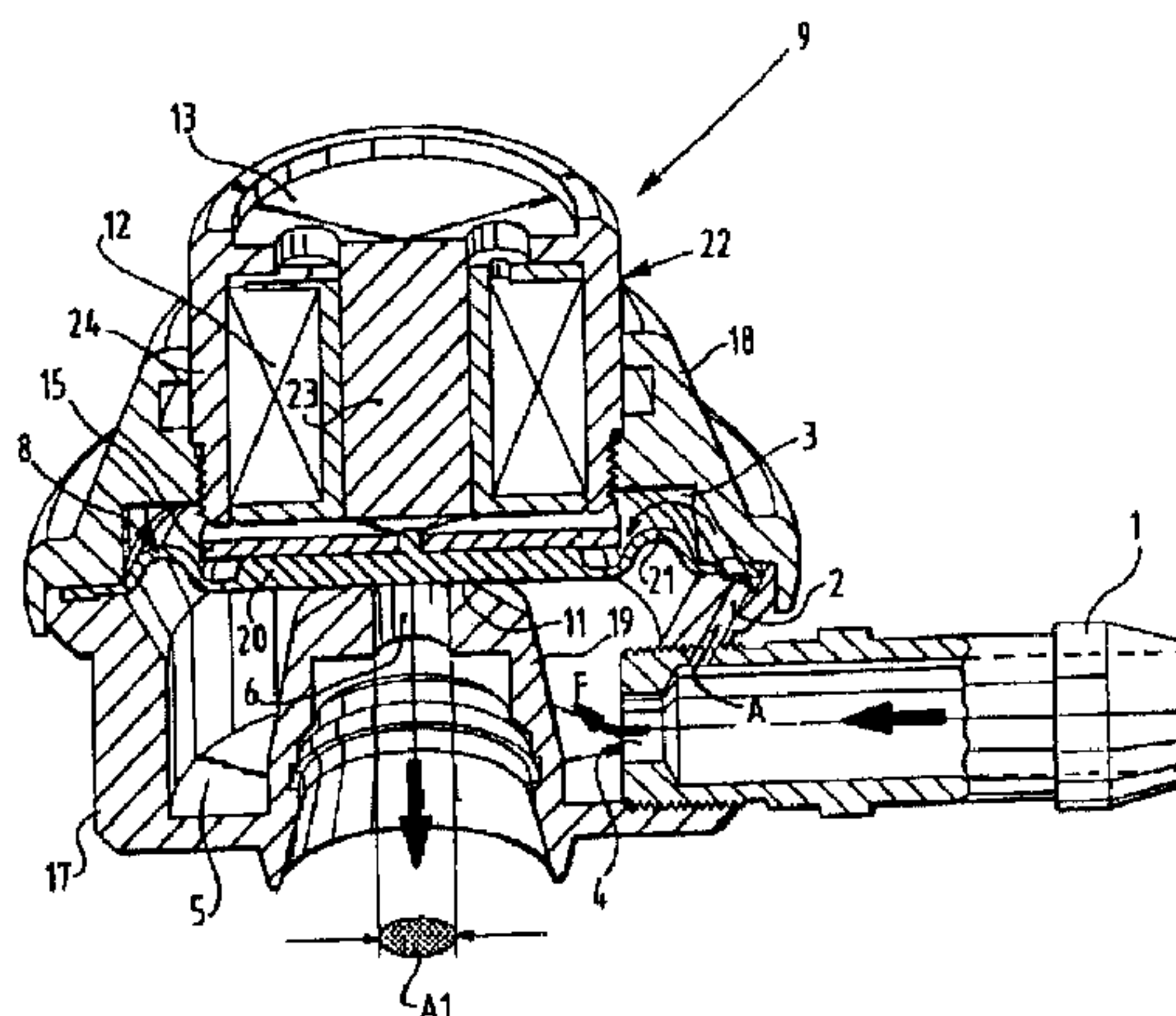

(57) L'invention concerne une soupape de dosage conçue pour un fluide et comportant un carter pourvu d'une ouverture de dosage et d'un élément de fermeture mobile. Cet élément de fermeture est sollicité vers une de ses positions par des moyens de sollicitation exerçant une action avec ledit élément et se présentant sous la forme d'un ressort pneumatique ou hydraulique, ledit élément pouvant être placé dans une autre position s'opposant à la sollicitation par des moyens opérationnels. Ce ressort pneumatique ou hydraulique peut être commandé par le fluide à doser. L'élément de fermeture peut être une membrane possédant une partie centrale relativement rigide et une partie bord relativement souple. Une ouverture d'alimentation reliée à un conduit d'alimentation du fluide à doser peut être située dans le carter des deux côtés de la membrane. Elle concerne, de plus, un système servant à alimenter en carburant un moteur à combustion et comprenant un réservoir de carburant et un conduit d'alimentation reliant le réservoir au moteur et logeant une ou plusieurs soupapes de ce type.

(57) The invention relates to a metering valve (9) for a fluid, provided with a housing with a metering opening and a movable closing member. The closing member (8) is biased to one of its positions by biasing means co-acting therewith in the form of a pneumatic or hydraulic spring, and can be placed in another position counter to the bias by operating means. The pneumatic or hydrolic spring can herein be driven by the fluid for metering. The closing member (8) can be a diaphragm with a relatively stiff central portion (20) and a relatively flexible edge portion (21). A supply opening connected to a feed conduit (1) for the fluid for metering can be arranged in the housing on either side of the diaphragm. The invention further relates to a system for supplying fuel to a combustion engine, provided with a container for the fuel and a feed line connecting the container to the engine, in which line is received one or more metering valves of the above described type.



PCT

WORLD INTELLECTUAL PROPERTY ORGANIZATION
International Bureau

INTERNATIONAL APPLICATION PUBLISHED UNDER THE PATENT COOPERATION TREATY (PCT)

(51) International Patent Classification ⁶ : F16K 31/06	A1	(11) International Publication Number: WO 99/64773 (43) International Publication Date: 16 December 1999 (16.12.99)
<p>(21) International Application Number: PCT/EP99/04036</p> <p>(22) International Filing Date: 9 June 1999 (09.06.99)</p> <p>(30) Priority Data: 1009355 9 June 1998 (09.06.98) NL 98204495.0 31 December 1998 (31.12.98) EP</p> <p>(71) Applicant (for all designated States except US): AUTO-GASTECHNIEK HOLLAND B.V. [NL/NL]; Galileistraat 15, NL-3902 HR Veenendaal (NL).</p> <p>(72) Inventor; and (75) Inventor/Applicant (for US only): VAN DEN BRINK, Alfred [NL/NL]; Lange Voren 12, NL-3773 AR Barneveld (NL).</p> <p>(74) Agent: BARTELDS, Erik; Arnold & Siedsma, Sweelinckplein 1, NL-2517 GK The Hague (NL).</p>	<p>(81) Designated States: AE, AL, AM, AT, AU, AZ, BA, BB, BG, BR, BY, CA, CH, CN, CU, CZ, DE, DK, EE, ES, FI, GB, GD, GE, GH, GM, HR, HU, ID, IL, IN, IS, JP, KE, KG, KP, KR, KZ, LC, LK, LR, LS, LT, LU, LV, MD, MG, MK, MN, MW, MX, NO, NZ, PL, PT, RO, RU, SD, SE, SG, SI, SK, SL, TJ, TM, TR, TT, UA, UG, US, UZ, VN, YU, ZA, ZW, ARIPO patent (GH, GM, KE, LS, MW, SD, SL, SZ, UG, ZW), Eurasian patent (AM, AZ, BY, KG, KZ, MD, RU, TJ, TM), European patent (AT, BE, CH, CY, DE, DK, ES, FI, FR, GB, GR, IE, IT, LU, MC, NL, PT, SE), OAPI patent (BF, BJ, CF, CG, CI, CM, GA, GN, GW, ML, MR, NE, SN, TD, TG).</p> <p>Published <i>With international search report.</i> <i>Before the expiration of the time limit for amending the claims and to be republished in the event of the receipt of amendments.</i></p>	

(54) Title: METERING VALVE AND FUEL SUPPLY SYSTEM EQUIPPED THEREWITH

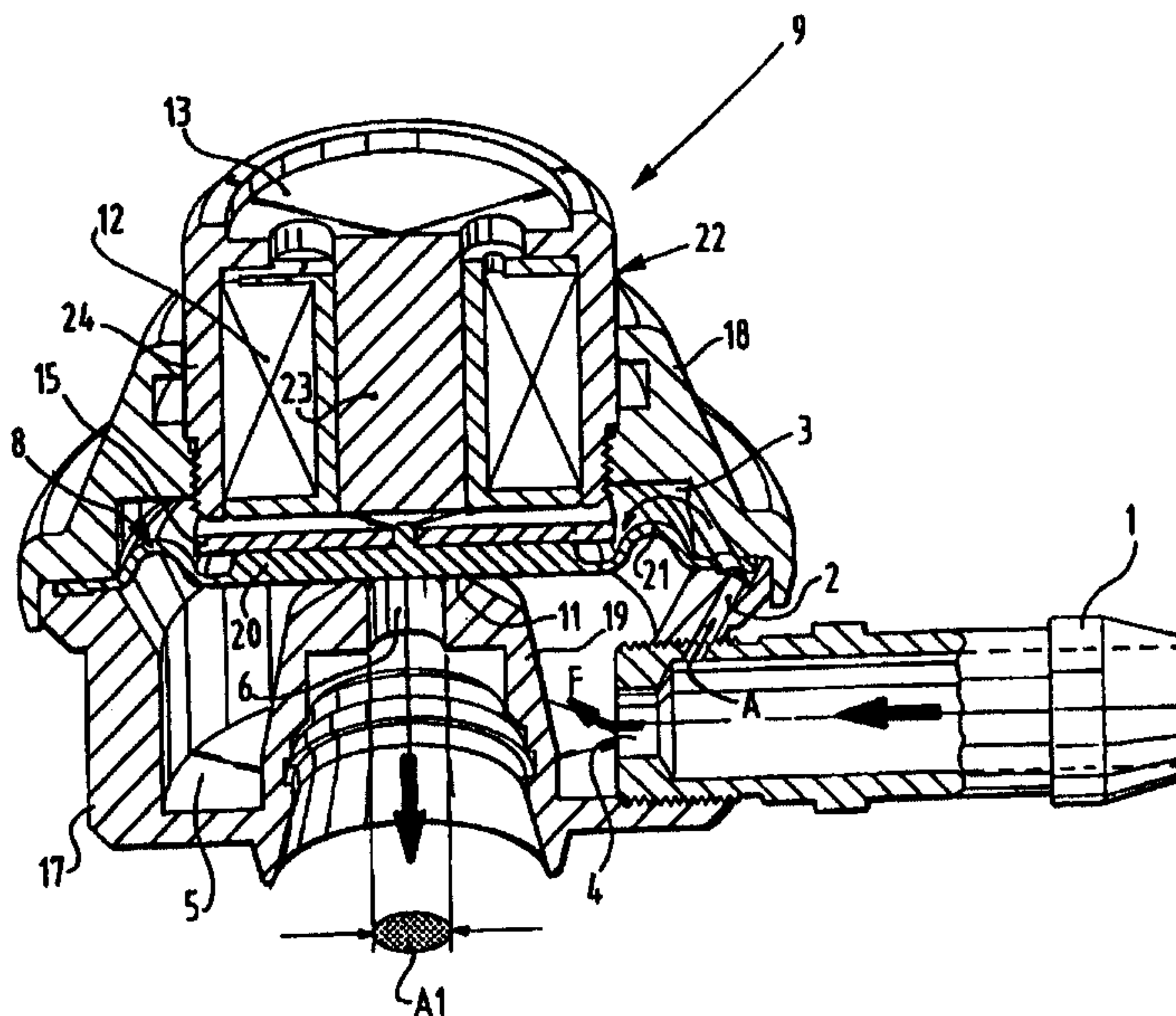

(57) Abstract

The invention relates to a metering valve (9) for a fluid, provided with a housing with a metering opening and a movable closing member. The closing member (8) is biased to one of its positions by biasing means co-acting therewith in the form of a pneumatic or hydraulic spring, and can be placed in another position counter to the bias by operating means. The pneumatic or hydraulic spring can herein be driven by the fluid for metering. The closing member (8) can be a diaphragm with a relatively stiff central portion (20) and a relatively flexible edge portion (21). A supply opening connected to a feed conduit (1) for the fluid for metering can be arranged in the housing on either side of the diaphragm. The invention further relates to a system for supplying fuel to a combustion engine, provided with a container for the fuel and a feed line connecting the container to the engine, in which line is received one or more metering valves of the above described type.

METERING VALVE AND FUEL SUPPLY SYSTEM EQUIPPED THEREWITH

The invention relates to a valve for metering a fluid, provided with a housing with at least one metering opening and at least one closing member which is movable between a position closing the opening and a position
5 leaving the opening at least partially clear, which closing member is biased by biasing means co-acting therewith to one of its positions and can be placed in the other position counter to the bias by operating means. Such a metering valve is known and is used for
10 instance in fuel injection systems, particularly systems for injecting gaseous fuel, such as the LPG injection system marketed by applicant under the name DGI.

Current metering valves or vapour injectors are provided with a closing member or plunger which is pulled
15 from the seat by an electromagnet counter to the force of a mechanical spring and which is pressed by the spring back onto the seat after the electromagnetic force has been removed. Because the plunger must be opened counter to a spring force, the force required of the
20 electromagnet is greater than should actually be necessary. Both the electromagnetic coil and the plunger must hereby be embodied disproportionately larger and heavier than would be necessary in the absence of the spring.

25 The unnecessarily heavy plunger causes problems in respect of the so-called rebound, i.e. the rebound which occurs when the heavy plunger strikes at great speed against the upper stop at the end of the attractive phase of the electromagnet. This phenomenon of rebound results
30 in a non-linear and unstable metering behaviour, which is furthermore temperature and injector-dependent. As a result it is not easily possible to produce this type of vapour injector in large numbers with sufficient precision.

In the DGI system of applicant already mentioned above, this problem is solved by using a control of the vapour injector with feedback, whereby variations in the metering behaviour as a result of rebound are measured 5 and can be corrected by feedback. However, this system is relatively expensive and therefore particularly suitable for group injection or monopoint injection, wherein a single central injector is present for metering of the gas, which is then guided alternately to the desired 10 cylinders via a nozzle.

The invention therefore has for its object to provide an improved metering valve which is simpler, smaller and lighter than the known valve and which can thus be manufactured at lower cost. Such a valve would 15 then be suitable for application in a system of individual injection per cylinder, or a multipoint injection system.

According to the invention this is achieved in that the biasing means comprise at least one pneumatic or 20 hydraulic spring. Preferred embodiments of the metering valve according to the invention form the subject-matter of the dependent claims.

Owing to the pneumatic (or hydraulic) closing of the valve, preferably a diaphragm, optionally in combination 25 with the electromagnetic opening thereof, the use of spring force becomes unnecessary. The coil and the plunger can hereby take a small and light form such that the problem of rebound no longer occurs. The pneumatic or hydraulic spring is preferably operated by the fluid 30 for metering. By using the fluid itself to operate the valve a simple and robust construction is obtained with relatively few components.

The operating means can advantageously be of electromagnetic type, whereby a simple control is 35 possible. The operating means can herein then comprise a coil with U-shaped armature and at least one metal attraction element connected to the closing member. This attraction element is preferably plate-like. Thus, as a

result of the chosen embodiment with the U-shaped armature and flat plunger plate, a relatively small electromagnetic force is required, so that a so-called high-impedance coil can suffice. This has the further
5 consequence that the electrical control can be provided using a simple low side driver, such as is also known from modern petrol injection systems. If the metering behaviour of the valve were made the same as that of a petrol injector, it would even be possible to control the
10 valve directly from the engine management computer of the petrol engine.

The closing member is preferably formed by a diaphragm. Such a diaphragm is light and of simple construction and can be operated with little force. The
15 diaphragm then advantageously has a relatively stiff central portion co-acting with the opening for closing, and a relatively flexible edge portion. A good sealing and yet easy deformability of the diaphragm are thus obtained simultaneously.

20 The closing member can be accommodated in a housing which has on either side of the closing member at least one supply opening connected to a feed conduit for the fluid for metering. The closing member can thus be operated by admitting fluid on either side thereof. The
25 supply openings are preferably dimensioned herein such that the fluid pressure in the housing on the side of the closing member directed toward the opening for closing is lower than the pressure on the opposite side thereof.

The invention further also relates to a system for
30 supplying fuel to a combustion engine, provided with a container for the fuel and at least one feed line connecting the container to the engine, in which line is received at least one metering valve of the above described type. The engine herein preferably has a number
35 of combustion chambers and at least one metering valve is present for each combustion chamber. A precisely operating multipoint injection system is thus obtained

which can be manufactured in simple manner and at low cost.

The invention will now be elucidated on the basis of an embodiment, wherein reference is made to the annexed drawing, in which:

fig. 1 is a cross-sectional perspective view of a metering valve according to the invention, and

fig. 2 shows schematically the structure of a fuel supply system in which such a metering valve is arranged for each cylinder.

A metering valve 9 (fig. 1) comprises a housing which consists of a base part 17 and a cover 18 placed sealingly thereon. A closing member 8 is arranged between cover 18 and base part 17 whereby the interior of the housing is divided into a control chamber 3 and a through-flow chamber 5. This through-flow chamber 5 is connected to a gas supply line 1 and a gas discharge line (not shown here). The gas discharge line is herein received in a connecting piece 19 to which through-flow chamber 5 is connected via an outlet opening 6. Around this outflow opening 6 is formed an annular valve seat 11 against which closing member 8 lies sealingly.

Closing member 8 here takes the form of a circular plastic diaphragm with a relatively stiff central portion 20 which co-acts with seat 11 around outlet opening 6 and a relatively flexible edge portion 21 situated round central portion 20. This edge portion 21 takes a curved form in cross-section, whereby it allows relatively large movements of central portion 20. Fixed onto central portion 20 is a plate-like metal attraction element 15 which forms part of the operating means for closing member 8. These operating means further comprise an electromagnet 22 formed by an armature 13 and a coil 12 wound therearound. Armature 13 herein comprises a core 23 and a cylindrical part 24 and therefore has in cross-section the form of a reverse W-shape or a pair of reverse U-shapes.

Both through-flow chamber 5 and control chamber 3 lying thereabove are connected to gas supply line 1. Recessed for this purpose in the wall of base part 17 and in the wall of cover 18 is a branch line 2 through which the fluid supplied through line 1 can flow to the control chamber. Further arranged between gas supply line 1 and through-flow chamber 5 is a narrowed passage or 'throttle' 4, the function of which is described below.

The metering valve 9 according to the invention now operates as follows. Vaporous fuel is supplied from an evaporator 10 via a conduit 7 (fig. 2) to the gas supply line 1 and flows via passage 4 to through-flow space 5 beneath closing member 8. A part of the fuel simultaneously flows through branch channel 2 to control space 3 above diaphragm 8. The same gas pressure herein prevails on either side of diaphragm 8. On the upper side this pressure acts on the entire surface area of the diaphragm but on the underside only on the part of diaphragm 8 outside the seat 11. As a consequence of the thereby created difference in area A1, a closing force is generated whereby closing member 8 is pressed onto seat 11 and held fixedly in a position closing off outlet opening 6 of valve 9.

When the coil 12 of the electromagnet above closing member 8 is energized, an electromagnetic force is created between the armature 13 of coil 12 and the metal plate 15 fixed onto closing member 8. Closing member 8 is hereby pulled against armature 13 and outlet opening 6 is left clear. The vaporous fuel then flows from supply line 1 via passage 4 to outlet opening 6, which debouches via the discharge line (not shown) into the inlet manifold 14 of an associated cylinder of a combustion engine 16.

The narrowed passage 4 herein functions as 'throttle' or differential pressure regulator, whereby as a result of the flow of the fuel a pressure difference is generated between the through-flow chamber 5 beneath the diaphragm-like closing member 8 and the control chamber 3 thereabove. The downward directed suction force which is

the result of the pressure difference is however overcome in this situation by the upward directed force which electromagnet 22 exerts on closing member 8. As soon as coil 12 is no longer energized however, the downward directed suction force immediately results in a downward directed displacement of closing member 8 to seat 11, whereby opening 6 is closed.

As a result of the simple and therefore low-cost construction thereof, the above described metering valve 9 can, as stated, be used advantageously in a system of individual injection per cylinder, i.e. a multipoint injection system as shown in fig. 2. It is however also conceivable to apply valve 9 as single metering valve in a system with central fuel injection.

The invention is not limited to the above discussed embodiments and the scope of the invention is therefore defined solely by the following claims.

¶ 7

PCT/EP99/04036 (encl. with letter of 31.08.2000)

NEW INDEPENDENT CLAIM

1. Valve (9) for metering a fluid, comprising a housing connected to a fluid supply line (1) and including at least one metering opening (6) and at least one closing member (8) which is movable in the housing
5 between a position closing the metering opening (6) and a position leaving the opening (6) at least partially clear, the closing member (8) being biased by at least one pneumatic or hydraulic spring co-acting therewith to its closed position and being arranged to be placed in
10 the other position counter to the bias by operating means, the pneumatic or hydraulic spring being driven by the fluid for metering and comprising two chambers (3, 5) arranged in the housing and separated by the closing member (8), each chamber (3, 5) having at least one
15 supply opening connected to the fluid supply line (1), the fluid supply line (1) being connected to the housing at the same side of the closing member (8) as the metering opening (6), the chamber (5) at that side of the closing member (8) forming a through-flow chamber and the
20 chamber (3) at the opposite side of the closing member (8) constituting a control chamber, the supply openings in the chambers (3, 5) being dimensioned such that the pressure of the fluid in the through-flow chamber (5) is lower than the pressure in the control chamber (3),
25 **characterized in that** the valve (9) is configured such that the closing member (3) is biased to its closed position solely by the pneumatic or hydraulic spring.

AMENDED SHEET

17. 07. 2000

18

NEW CLAIMS

(55)

1. Valve (9) for metering a fluid, comprising a housing connected to a fluid supply line (1) and including at least one metering opening (6) and at least one closing member (8) which is movable in the housing
5 between a position closing the metering opening (6) and a position leaving the opening (6) at least partially clear, the closing member (8) being biased by at least one pneumatic or hydraulic spring co-acting therewith to one of its positions and being arranged to be placed in
10 the other position counter to the bias by operating means, the pneumatic or hydraulic spring being driven by the fluid for metering and comprising two chambers (3, 5) arranged in the housing and separated by the closing member (8), each chamber (3, 5) having at least one
15 supply opening connected to the fluid supply line (1), **characterized in that** the fluid supply line (1) is connected to the housing at the same side of the closing member (8) as the metering opening (6), the chamber (5) at that side of the closing member (8) forming a through-
20 flow chamber and the chamber (3) at the opposite side of the closing member (8) constituting a control chamber, the supply openings in the chambers (3, 5) being dimensioned such that the pressure of the fluid in the through-flow chamber (5) is lower than the pressure in
25 the control chamber (3).

2. Metering valve (9) as claimed in claim 1, **characterized in that** the supply opening in the through-flow chamber (5) is connected to the fluid supply line (1) through a narrowed passage (4).

30 3. Metering valve (9) as claimed in claim 1 or 2, **characterized in that** the supply opening in the control chamber (3) is connected to the fluid supply line (1) through a branch line (2) arranged in a wall of the housing.

2 9

4. Metering valve (9) as claimed in any of the preceding claims, **characterized in that** the closing member (8) is a diaphragm.

5. Metering valve (9) as claimed in claim 4,
5 **characterized in that** the diaphragm (8) comprises a relatively stiff central portion (20) co-acting with the metering opening (6) and a relatively flexible edge portion (21).

6. Metering valve (9) as claimed in any of the
10 preceding claims, **characterized in that** the operating means are of electromagnetic type.

7. Metering valve (9) as claimed in claim 3,
characterized in that the operating means comprise a coil (12) with W-shaped armature (13) and at least one metal
15 attraction element (15) connected to the closing member (8).

8. Metering valve (9) as claimed in claim 7,
characterized in that the attraction element (15) is plate-like.

20 9. System for supplying fuel to a combustion engine (16), provided with a container for the fuel and at least one feed line connecting the container to the engine (16), in which line is received at least one metering valve (9) as claimed in any of the preceding
25 claims.

10. Fuel supply system as claimed in claim 9,
characterized in that the engine (16) has a number of combustion chambers and at least one metering valve (9) is present for each combustion chamber.

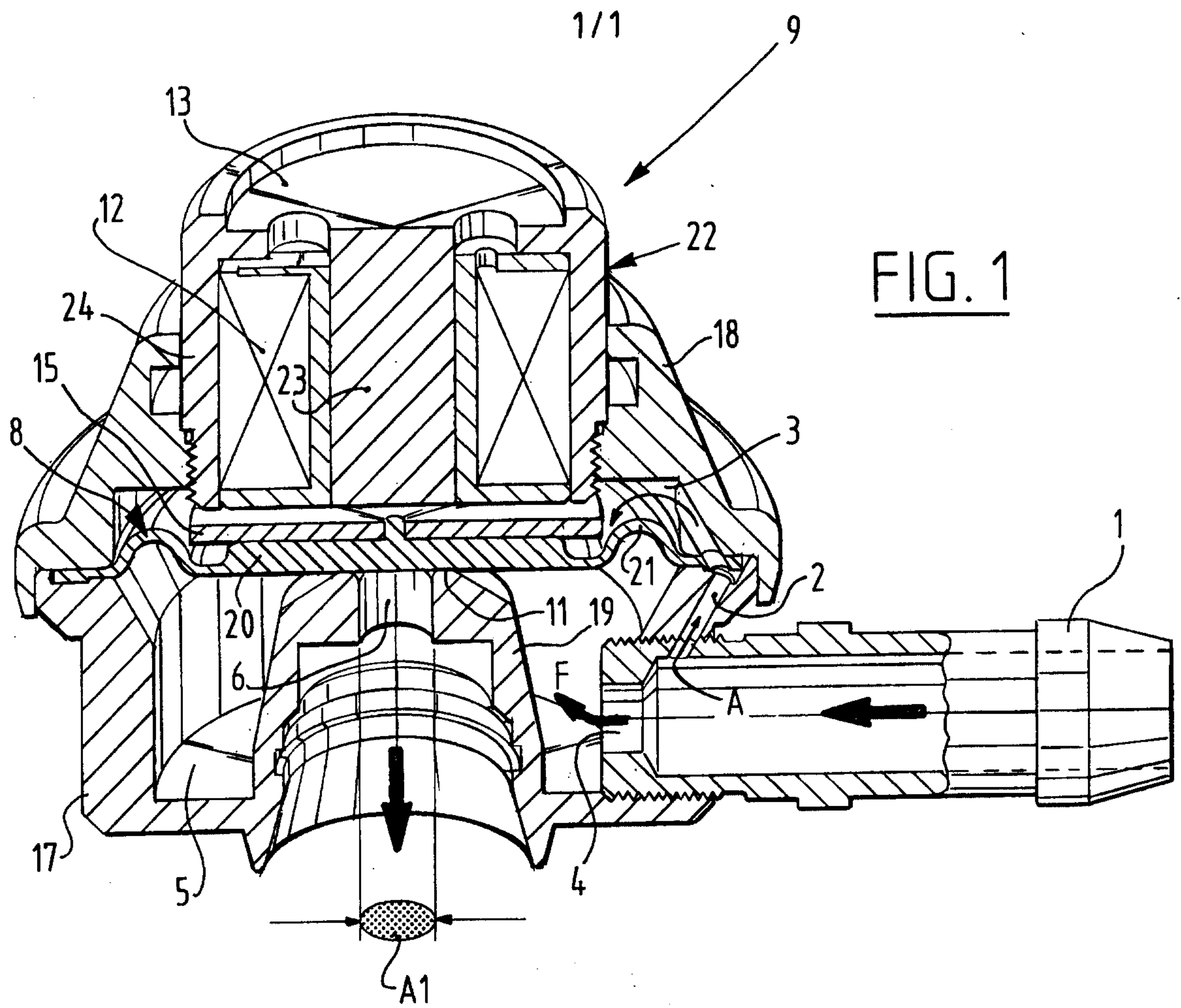

FIG. 1

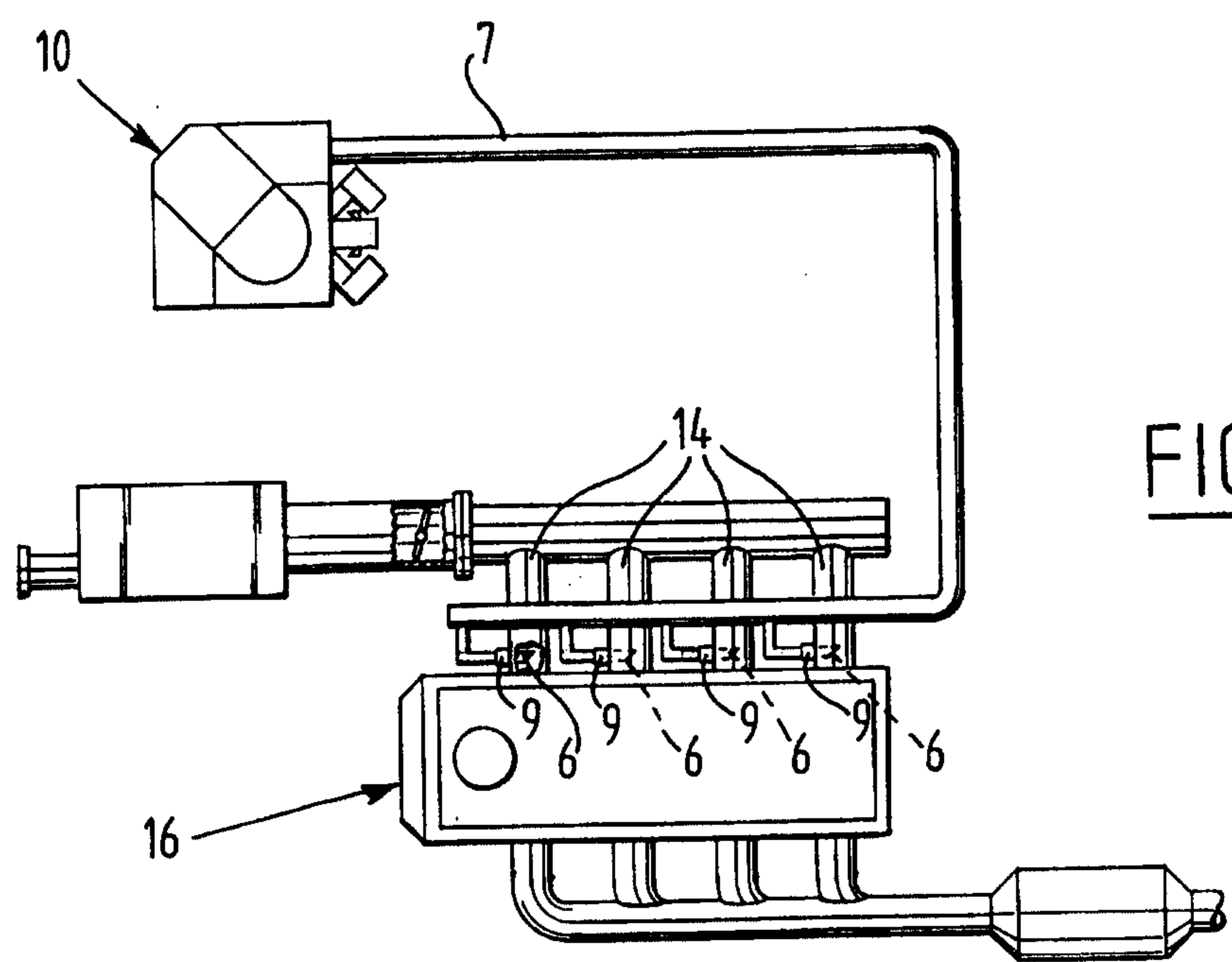

FIG. 2

