

(No Model.)

A. REINEMANN.
FIRE EXTINGUISHER.

No. 466,801.

Patented Jan. 12, 1892.

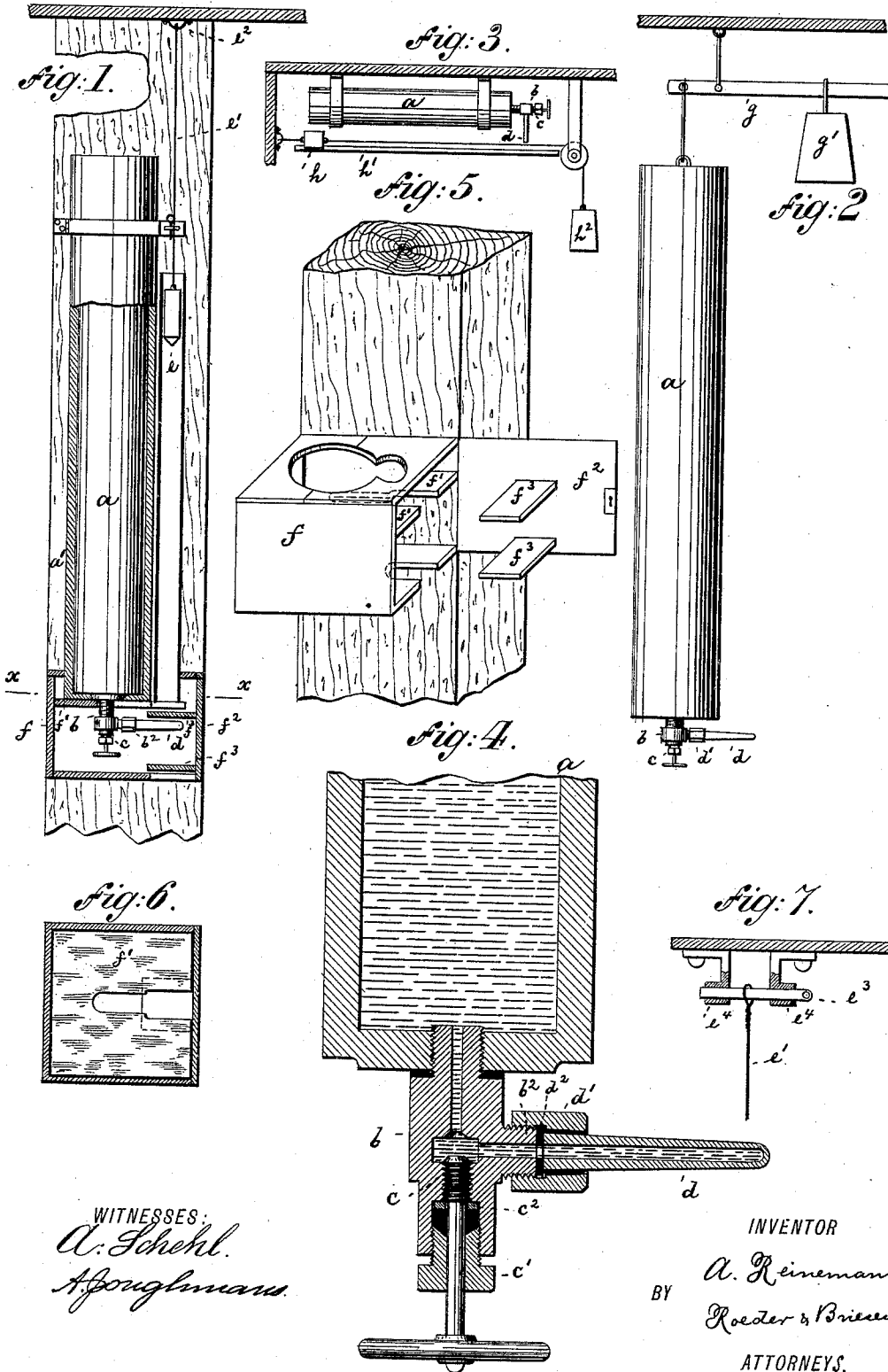

WITNESSES:
A. Schehl.
A. Soughmann.

INVENTOR
A. Reinemann
BY *Roeder & Brice*
ATTORNEYS.

UNITED STATES PATENT OFFICE.

ADOLPH REINEMANN, OF NEW YORK, N. Y.

FIRE-EXTINGUISHER.

SPECIFICATION forming part of Letters Patent No. 466,801, dated January 12, 1892.

Application filed May 1, 1891. Serial No. 391,284. (No model.)

To all whom it may concern:

Be it known that I, ADOLPH REINEMANN, of New York city, New York, have invented an Improved Fire-Extinguisher, of which the following is a specification.

This invention relates to that class of extinguishers in which a body of liquefied carbonic acid is released to commingle with the air.

The underlying principle employed in my invention consists in the automatic or mechanical release of a weight which in its fall meets and breaks a tube of glass or other fragile material, and thus liberates the gas.

The invention consists in the various features of improvement more fully pointed out in the claims.

In the accompanying drawings, Figure 1 is a side elevation, partly in section, of my improved fire-extinguisher. Fig. 2 is a side elevation of the same, showing it counter-balanced; Fig. 3, a side view of a modification; Fig. 4, a detail vertical central section through the lower part of the apparatus; Fig. 5, a perspective of the box *f*; Fig. 6, a section on line *x x*, Fig. 1. Fig. 7 is a modification of the suspending mechanism.

The letter *a* represents a vessel of suitable form and material, such as wrought-iron or other metal, designed for the reception of liquefied carbonic-acid gas and provided, if desired, with an asbestos jacket *a'*. At the lower end the vessel *a* is provided with a stop-cock *b*, having the threaded valve *c*, that regulates the discharge of the fluid. The valve-stem passes through a threaded plug *c'*, placed beneath a washer *c''*, all as usual in this class of vessels.

*b*² is a nozzle with which the stop-cock is provided. To this nozzle there is secured a fragile tube *d* in such a way that the bore of the tube constitutes a continuation of the bore of the nozzle. This bore is of such a reduced diameter that it will receive only a very small quantity of the liquefied carbonic-acid gas. The pressure produced by this small quantity of the liquefied gas is insufficient to break the tube. The outer end of the tube *d* is closed, and thus the tube is in effect a stopper, which prevents the discharge of the gas through nozzle *b*². The tube *d* may be held in place by suitable

means. I have shown it to be attached by a nut or union *d'*, which is notched and engages an interposed gasket *d''* to produce a tight joint.

At any proper distance above the tube *d* there is suspended a weight *e*, which on descending will strike and break the tube to liberate the contents of the vessel *a*. The weight may be suspended either by means that will automatically release it at a given temperature or by means which must be operated by hand.

In Fig. 1 the wire or chain *e'*, to which the weight is attached, is held in place by a fusible loop *e''*, secured to the ceiling or other support. In Fig. 7 the wire *e'* is locked in place by a bolt *e'''*, received by the perforated brackets *e''''*.

In order to prevent the weight from breaking the tube *d* during working hours or at any other time when not desired, and also to prevent tampering with the apparatus, I may inclose the lower part of the latter by a box *f*, such as shown in Fig. 5. This box is provided with a false bottom *f'*, which, as well as the bottom proper, is cut away in line with the fall of the weight.

To the lid *f''* of the box there are secured two shelves *f'''*, which, when the lid is closed, are interposed between the line of fall of the weight and the tube *d*. It is evident that when the lid is locked the weight, even if released, cannot reach and break the tube; but when the lid is open the weight has access to the tube, and after breaking the same will leave the box through the opening in its bottom.

In Fig. 2 I have shown the vessel *a*, suspended from one end of a beam *g*, counter-balanced by weight *g'*. This is to indicate by leakage a substantial portion of the contents of the vessel *d* should have escaped, which would necessitate refilling.

In Fig. 3 the vessel *a* is shown to be placed in a horizontal position. A breaking-plug *h*, running on guide-rail *h'*, is by a weight *h''* drawn against tube *d*, when the plug *h* has been released.

What I claim is—

1. The combination of a metal liquefied-carbonic-acid-gas receptacle *a* with a communicating fragile tube of reduced diameter

and a weight suspended in line therewith, substantially as specified.

2. The combination of vessel *a* with a stop-cock *b*, having a nozzle *b*², a fragile tube secured to said nozzle, and a weight in line with the tube, substantially as specified.

3. The combination of vessel *a* with a frag-

ile tube *d*, communicating therewith, a weight *e*, and a box having shelf *f*³, adapted to intercept the weight, substantially as specified.

ADOLPH REINEMANN.

Witnesses:

F. V. BRIESEN,
A. JONGHMANS.