

(No Model.)

L. G. WOOLLEY.  
THERMOSTAT.

No. 563,831.

Patented July 14, 1896.

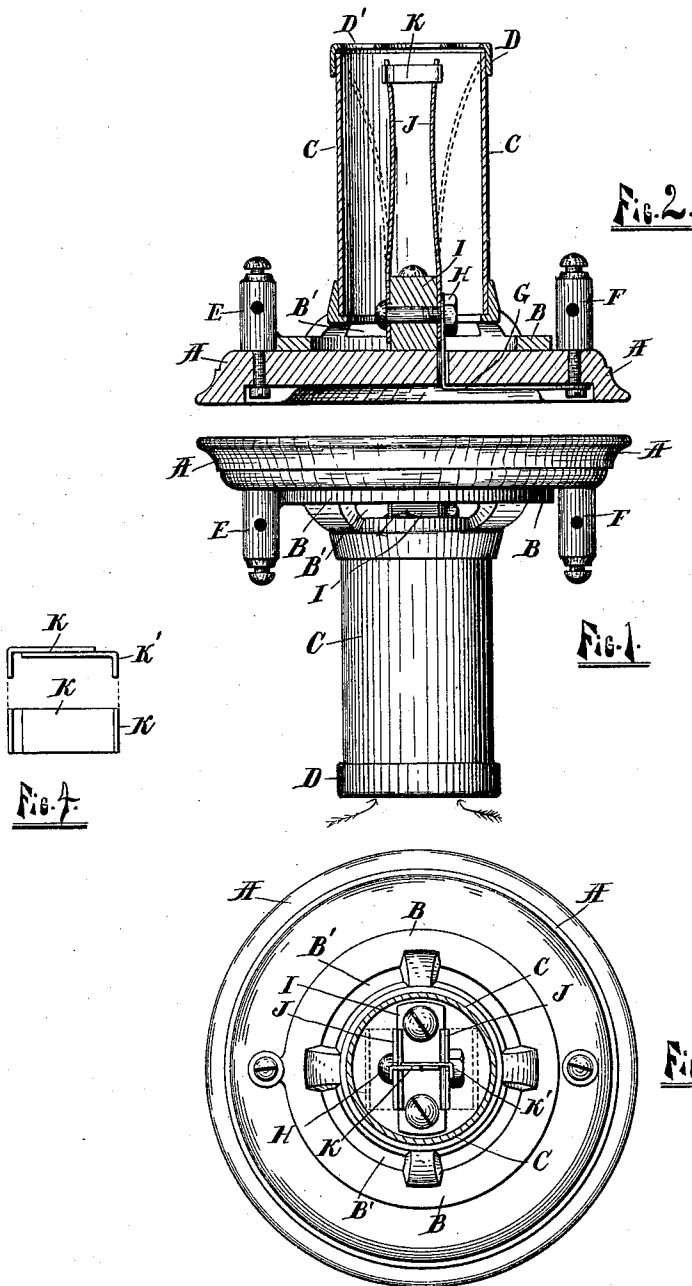

Witnesses  
*Lewis C. Flanders*  
*Levin Houston*

Inventor  
*Leonidas G. Woolley*  
By Attorney  
*Luther V. Moulton*

# UNITED STATES PATENT OFFICE.

LEONIDAS G. WOOLLEY, OF GRAND RAPIDS, MICHIGAN.

## THERMOSTAT.

SPECIFICATION forming part of Letters Patent No. 563,831, dated July 14, 1896.

Application filed June 24, 1895. Serial No. 553,783. (No model.)

*To all whom it may concern:*

Be it known that I, LEONIDAS G. WOOLLEY, a citizen of the United States, residing at Grand Rapids, in the county of Kent and State of Michigan, have invented certain new and useful Improvements in Thermostats; and I do hereby declare the following to be a full, clear, and exact description of the invention, such as will enable others skilled in the art to which it appertains to make and use the same.

My invention relates to improvements in thermostats for fire-alarm purposes, and its object is to provide a circuit-closing device that will mechanically remove any corrosion or other obstruction at the point of contact of the electrodes, thus insuring perfect closure of the circuit. Heretofore the closing of the circuit has been by some gradual approach of the parts or by direct approach of substantially plane surfaces, so that any corrosion, dust, or other obstruction was not mechanically removed from the contacting surfaces. I obtain the object sought by so arranging the electrodes that the point of contact to close the circuit shall be a sharp angle on an electrode which is suddenly released and actuated to forcibly strike a fixed electrode with a cutting and sliding action, whereby all corrosion, dust, or other obstruction is removed and clean metal brought in contact, thus electrically closing the circuit with effect and certainty. I obtain this result by the means hereinafter more fully described, and particularly pointed out in the claims, reference being had to the accompanying drawings, in which—

Figure 1 is a side elevation of a device embodying my invention; Fig. 2, a section of the same on the line 2 2 of Fig. 3. Fig. 3 is a plan view with the top removed, and Fig. 4 a detail of the clamp.

Like letters refer to like parts in all of the figures.

A is a circular base, to which is secured the flange B, having the openings B' and a socket to receive one end of the cylindrical electrode C, said electrode having its opposite end covered by a cap D, having the openings D'. Connected to the frame B and secured to the base A is the binding-post E, and at the opposite side of said base is secured the

binding-post F. An insulating-block I is secured in the axis of said base, and to the sides of said block are secured, by means of the bolt H, the upwardly-extending spring-electrodes J, said electrodes being held out of contact with the electrode C by means of the clamp K, which clamp fits edgewise into longitudinal slots in the ends of said electrodes J, and the laterally-extending end K' of said clamp engages the sides of the same. The clamp K consists of two parts made of strips of sheet metal, having their adjacent ends overlapped and secured to each other by fusible solder and their outer ends bent at right angles to engage the spring-electrodes. It is evident that any fusible means of connecting or holding and releasing the spring-electrodes may be used. I do not limit myself to the particular clamp shown. Said spring-electrodes are connected with the binding-post F by means of the metal strip G, which engages the bolt H at one end, and, passing through the base A, engages the screw which secures said post to said base at the other. The binding-post E is thus connected to the electrode C and the post F to the electrodes J, said posts being connected to the positive and negative wires, respectively, of an open fire-alarm circuit operating by closing the circuit.

When the temperature rises sufficiently to melt the solder which holds the two parts of the clamp K together, said electrodes will be released and the circuit closed. As one electrode is cylindrical and the other flat, when said flat electrodes are thus released they spring suddenly outward, their upper corners only striking said cylindrical electrode, the inertia of the spring causing vibration of the same, whereby said angles are reciprocated along the surface of the fixed electrode and with sufficient force to remove all corrosion, dust, or other obstruction at the point of contact. By this arrangement four points of contact are also provided to insure greater certainty in closing the circuit; also by this construction heated air is drawn through said casing, insuring the heating of the clamp and prompt release of the spring-electrodes.

I am aware that it is not new to combine a concave fixed electrode and a spring-electrode within the same having angles to engage the

fixed electrode, and a fusible non-conducting substance between said electrodes to separate the same, and by melting to permit said electrodes to come in contact. I do not claim such, broadly, but,

5 Having thus fully described my invention, what I claim is—

1. In a thermostat, in combination with a cylindrical casing adapted to serve as one  
10 electrode, two springs serving as the other electrode, and within said casing, and fusible means for securing said spring-electrodes to each other, and out of contact with said casing, substantially as described.

15 2. In a thermostat, in combination, spring-electrodes, fusible means for connecting the same, and a casing adapted to serve as an electrode inclosing said spring-electrodes and having openings at its ends, whereby a cir-  
20 culation of air is secured, substantially as described.

3. In a thermostat, in combination, a base, a casing, a flange on said casing, having openings and secured to said base, a cap on said

casing having openings, an insulating-block 25 secured to the axis of said base, spring-electrodes secured to said block, and a fusible clamp to hold said spring-electrodes substantially as described.

4. In a thermostat, in combination, a base, 30 a binding-post, secured thereto, an insulating-block secured to the axis of said base, spring-electrodes secured to said block, a strip passing through said base and connect-  
35 ing said post and said electrodes, a clamp having two parts separable by heat engaging said electrodes a casing adapted to serve as an electrode, a cap on said casing, having  
40 openings, a flange on said casing, having openings, and a binding-post connected to said flange and secured to said base, substantially as described.

In testimony whereof I affix my signature in presence of two witnesses.

LEONIDAS G. WOOLLEY.

Witnesses:

LUTHER V. MOULTON,  
LOIS MOULTON.