

(19) World Intellectual Property Organization  
International Bureau



(43) International Publication Date  
13 February 2003 (13.02.2003)

PCT

(10) International Publication Number  
WO 03/011594 A1

(51) International Patent Classification<sup>7</sup>: **B32B 31/00**,  
15/08, 1/10, B29C 70/88, 70/44

(21) International Application Number: PCT/NL02/00515

(22) International Filing Date: 30 July 2002 (30.07.2002)

(25) Filing Language: English

(26) Publication Language: English

(30) Priority Data:  
1018701 3 August 2001 (03.08.2001) NL

(71) Applicant (for all designated States except US):  
**FOKKER AEROSTRUCTURES B.V.** [NL/NL];  
Industrieweg 4, NL-3351 LB Papendrecht (NL).

(72) Inventor; and

(75) Inventor/Applicant (for US only): **RAJABALI, Abdoel,**  
**Faziel** [NL/NL]; Fideliohof 70, NL-2402 ET Alphen A/D  
Rijn (NL).

(74) Agent: **JORRITSMA, RUURD**; Nederlandsch Oc-  
trooibureau, Scheveningseweg 82, P.O. Box 29720,  
NL-2502 LS The Hague (NL).

(81) Designated States (national): AE, AG, AL, AM, AT, AU,  
AZ, BA, BB, BG, BR, BY, BZ, CA, CH, CN, CO, CR, CU,  
CZ, DE, DK, DM, DZ, EC, EE, ES, FI, GB, GD, GE, GH,  
GM, HR, HU, ID, IL, IN, IS, JP, KE, KG, KP, KR, KZ, LC,  
LK, LR, LS, LT, LU, LV, MA, MD, MG, MK, MN, MW,  
MX, MZ, NO, NZ, OM, PH, PL, PT, RO, RU, SD, SE, SG,  
SI, SK, SL, TJ, TM, TN, TR, TT, TZ, UA, UG, US, UZ,  
VN, YU, ZA, ZM, ZW.

(84) Designated States (regional): ARIPO patent (GH, GM,  
KE, LS, MW, MZ, SD, SL, SZ, TZ, UG, ZM, ZW),  
Eurasian patent (AM, AZ, BY, KG, KZ, MD, RU, TJ, TM),  
European patent (AT, BE, BG, CH, CY, CZ, DE, DK, EE,  
ES, FI, FR, GB, GR, IE, IT, LU, MC, NL, PT, SE, SK,  
TR), OAPI patent (BF, BJ, CF, CG, CI, CM, GA, GN, GQ,  
GW, ML, MR, NE, SN, TD, TG).

**Published:**

— with international search report

For two-letter codes and other abbreviations, refer to the "Guidance Notes on Codes and Abbreviations" appearing at the beginning of each regular issue of the PCT Gazette.

(54) Title: METHOD AND MOULD FOR THE PRODUCTION OF A LAMINATED PANEL

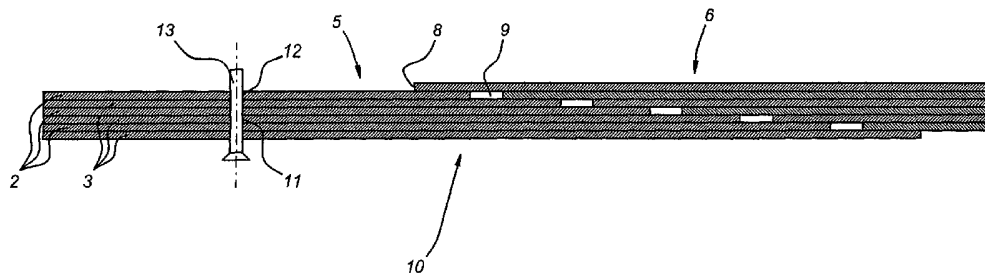

(57) Abstract: A method for the production of a panel (1) from a laminate that comprises at least two metal layers (2) and an intermediate layer (3) consisting of an adhesive material, comprising the following steps: provision of a mould (4) for the panel (1), placing a pack (5, 6) of alternating layers of metal (2) and adhesive material (3) in the mould, making at least one hole (11) through the pack (5, 6), placing a fixing means (16) in each hole (11), subjecting the pack (5, 6) to elevated pressure, activating the adhesive material (3), removing the panel (1) from the mould (4), removing each fixing means (16).



WO 03/011594 A1

Method and mould for the production of a laminated panel

The invention relates to the production of panels having a laminated structure. Such panels are used in a wide variety of fields. By means of suitable choice of material for the various layers, specific characteristics can be obtained, for example with regard to the strength and rigidity. A particular application is in aviation and aerospace technology. The panels used in this field must, on the one hand, have a low weight and, on the other hand, have strength and rigidity characteristics such that they are able to withstand the stresses to which a self-supporting body or wing construction is exposed. Furthermore, they must meet stringent requirements with regard to fatigue strength and toughness.

The panels can be produced in various ways. The invention relates in particular to the production of such panels under elevated pressure and temperature. For this purpose the panels on a mould are covered by a membrane; the pressure is lowered in the gap between the mould and the membrane. The mould prepared in this way is then placed in an autoclave, after which the adhesive contained between the layers is activated. The elevated pressure in the autoclave must ensure that the various layers are held pressed onto one another, such that they are not able to shift with respect to one another during the production process.

However, especially in the case of panels with relatively large numbers of layers, the problem arises that the mutual position thereof during the production process can not be well controlled. The adhesive becomes fluid on heating, with the consequence that the layers are able to shift with respect to one another. This problem arises in particular in the case of panels composed of layers of different dimensions, such as is the case, for example, with panels with local reinforcement. The reinforcements concerned here can be reinforcements that have to be provided in the vicinity of openings in the panel, such as window and door openings.

In the aviation industry the panels produced in this way are incorporated in the fuselage and wings. In this case stringers and trusses are fixed to the inside of the panels. Fixing is usually carried out by riveting. For this purpose holes have to be drilled in the panels in positions accurately determined in advance. Since, from the standpoint of the quality of the construction, it is not acceptable that such holes are made in the edge of one or more layers, a very wide margin has to be maintained on either side of these edges. However, for reasons of freedom of design this is highly undesirable.

The aim of the invention is therefore to provide a method for the production of a panel with which the position of the layers with respect to one another is determined more accurately. Said aim is achieved by means of a method for the production of a panel from a laminate that comprises at least two layers of metal and an intermediate layer consisting of an adhesive material, comprising the following steps:

- 5 - provision of a mould for the panel,
- placing a pack of alternating layers of metal and adhesive material in the mould,
- making at least one hole through the pack,
- placing a fixing means in each hole,
- 10 - subjecting the pack to elevated pressure,
- activating the adhesive material,
- removing the panel from the mould,
- removing each fixing means.

With the method according to the invention the various layers, which initially are still lying loosely on top of one another, are fixed with respect to one another by means of, for example, a pin or screw. Such a pin per se fits in the various layers with some tolerance. Consequently, slight shifting of the layers with respect to one another is still possible, but this shifting is so slight, in any event one or more orders of magnitude smaller compared with unrestrained shifting, that an appreciably improved positional accuracy of the various layers with respect to one another is achieved.

Furthermore, panels are known which are made up of part panels with equal numbers of layers. These layers overlap one another in pairs at their adjacent edges. The problems outlined above also arise in the production of such composite panels. In this context as well, the invention provides an improved method for the production of a panel from a laminate in which there is a seam with overlapping layers, comprising the following steps:

- 25 - placing at least a second pack of alternating layers of metal and adhesive material in the mould,
- overlapping the layers of packs adjoining one another,
- making at least one hole through each additional pack,
- 30 - placing a fixing means in each additional hole.

The seam is now in an accurately determined position, which facilitates treatment of the panels. According to a further variant of the method, the position of the pack of layers itself with respect to the mould can also be determined. This is important if the mould has

an irregular curved shape. Pack shifting then gives rise to an incorrect curved shape of the finished panel. According to the invention this can be prevented if the method comprises the following steps:

- providing a mould with at least one recess made beforehand,
- 5       - positioning a pack in the mould in such a way that the hole through the pack is aligned with respect to the recess,
- fitting the fixing means in the hole and the recess.

Incidentally, the holes that are made in the packs can be positioned such that after production of the panel they can also be used for fixing stringers and/or trusses. In this case  
10 the holes also do not have to constitute any unnecessary weakening in the panel. In some cases the positioning holes can also be made in those parts of the panel that are subsequently removed, for example at the location of the window and door openings.

As already mentioned, the invention also relates to a mould for use with the method described above. A known mould of this type has a mould surface onto which at least one  
15 pack of layers consisting of metal and adhesive can be placed, which pack has at least one hole through it in which a fixing means can be accommodated. According to the invention at least one recess for accommodating a fixing means opens at the mould surface. The recess can have an internal screw thread.

The invention also relates to a panel produced by means of the method described  
20 above. In the case of panels that are used in aircraft construction the metal layers consist of aluminium and the layer of adhesive material consists of a glass fibre matrix impregnated with an adhesive.

The invention will be further explained with reference to a few illustrative embodiments shown in the figures.

25       Figure 1 shows two layered packs with overlapping edges.

      Figure 2 shows a fixing means according to the invention.

      Figure 3 shows another fixing means.

      Figure 4 shows a finished panel.

With the method according to the invention a panel 1 is produced from a number of  
30 metal layers 2 between which layers 3 consisting of a glass fibre matrix with an adhesive embedded therein are accommodated. Packs of this type are accommodated on a mould 4, such as, for example, is shown in Figures 2 and 3. In a known manner a membrane (not shown) is placed over the pack 1, which membrane is joined at the edges to the mould 4

such that it is airtight.

The whole is then placed in an autoclave, in which both the pressure and the temperature are raised. During this operation the pack consisting of alternating layers 2 and 3 is pressed firmly onto the mould 4, as a result of which the desired shape is obtained. The adhesive present in the glass fibre matrix 3 also melts, as a result of which the adhesion between layers 2 is obtained. After cooling, the mould 4 with the panel, which is then finished, is removed from the autoclave.

In the example shown in Figure 1 two packs 5, 6 consisting of alternating layers 2, 3 are provided. The layers of these packs 5, 6 overlap one another at the location of their edges 8, whilst gaps 9 remain open between the layers. There is therefore a large number of end edges of the layers 2 in the seam 10.

When producing a panel from such packs 5, 6 it is extremely important that the end edges of the layers 2 are accurately positioned. Thus it is, specifically, also possible to drill a number of holes at the location of the seam 10, by means of which holes it is possible to fix, for example, a truss to the panel.

In connection with the desired accurate positioning of the end edges of the layers 2 with respect to one another, according to the invention a hole 11, 12 is drilled through the packs 5, 6, in which hole pin-shaped fixing means 13 are placed.

As shown in Figure 2, the individual gaps 14 in the metal layers 2, which together with the holes 15 in the layers 3 of matrix material form the hole 11 through the pack, are oversized to some extent in order to be able to fit the pin-shaped fixing means 16. However, the tolerance that plays a role here is relatively small, such that accurate positioning of the end edges of the layers 2 is still possible.

In the illustrative embodiment shown in Figures 1 and 2 the pin-shaped fixing means 16 are in the form of a screw and screwed into an insert 17 provided with an internal screw thread. By this means fixing of the packs 5, 6 with respect to the mould 4 is ensured at the same time, so that the panel acquires the desired shape.

In the illustrative embodiment in Figure 2 the pin-shaped fixing means 16 are provided with a screw head 18; in the illustrative embodiment in Figure 3 pin-shaped fixing means 16 with a flat head 19, the surface of which is in the same plane as that of the stringer 20, is used.

As shown in Figure 4, the panel 1 obtained in this way can be used as the fuselage section for an aircraft. By virtue of the accurately determined position of the end edges of

the individual layers 2, the trusses 21 can be fixed in place using evenly distributed rivets without there being a relatively large, unfixed region at the location of the seam 10 as a consequence of the position of the end edges of the layers 2 not being accurately determined.

Claims

1. Method for the production of a panel (1) from a laminate that comprises at least two layers of metal (2) and an intermediate layer (3) consisting of an adhesive material,  
5 comprising the following steps:

- provision of a mould (4) for the panel (1),
- placing a pack (5, 6) of alternating layers of metal (2) and adhesive material (3) in  
the mould (4),

- making at least one hole (11) through the pack (5, 6),
- 10 - placing a fixing means (16) in each hole (11),
- subjecting the pack (5, 6) to elevated pressure,
- activating the adhesive material (3),
- removing the panel (1) from the mould (4),
- removing each fixing means (16).

15

2. Method according to Claim 1 for the production of a panel (1) from a laminate in which there is a seam (10) with overlapping layers (2), comprising the following steps:

- placing at least a second pack (5, 6) of alternating layers of metal and adhesive  
material (3) in the mould (4),

- 20 - overlapping the layers (2) of packs (5, 6) adjoining one another,
- making at least one hole (11) through each additional pack (5, 6),
- placing a fixing means (16) in each additional hole (11).

3. Method according to one of the preceding claims, comprising the following steps:

- 25 - providing a mould (4) with at least one recess (17) made beforehand,
- positioning a pack (5, 6) in the mould (4) in such a way that the hole (11) through  
the pack is aligned with respect to the recess (17),
- fitting the fixing means (16) in the hole (11) and the recess (17).

30 4. Method according to Claim 3, wherein the recess (17) has an internal screw thread and the fixing means (16) are in the form of a screw, comprising screwing said fixing means (16) into the recess (17).

5. Method according to one of the preceding claims, comprising the following steps:

- placing a gas-tight membrane over the mould (4) with pack (s) (5, 6),
- subjecting the membrane to elevated pressure,
- heating each pack (5, 6).

5

6. Method according to Claim 5, comprising carrying out the steps of raising the pressure and the temperature in an autoclave.

7. Mould for use with the method according to Claim 3 or 4, comprising a mould surface onto which at least one pack of layers (5, 6) consisting of metal (2) and adhesive (3) can be placed, which pack has at least one hole (11) through it in which a fixing means can be accommodated, characterised in that at least one recess (17) for accommodating fixing means (16) opens at the mould surface.

8. Mould (4) according to Claim 7, wherein the recess (11) has an internal screw thread.

9. Panel (1) produced by means of the method according to one of Claims 1-6.

10. Panel (1) according to Claim 9, wherein the metal layers (2) consist of aluminium and the layer of adhesive material (3) consists of a glass fibre matrix impregnated with an adhesive.

Fig 1

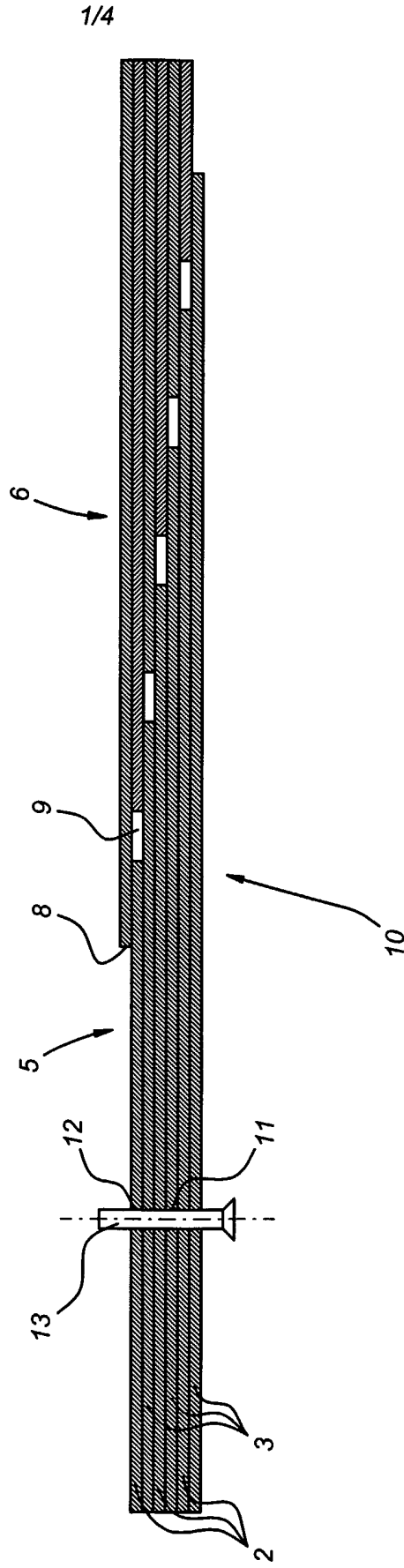

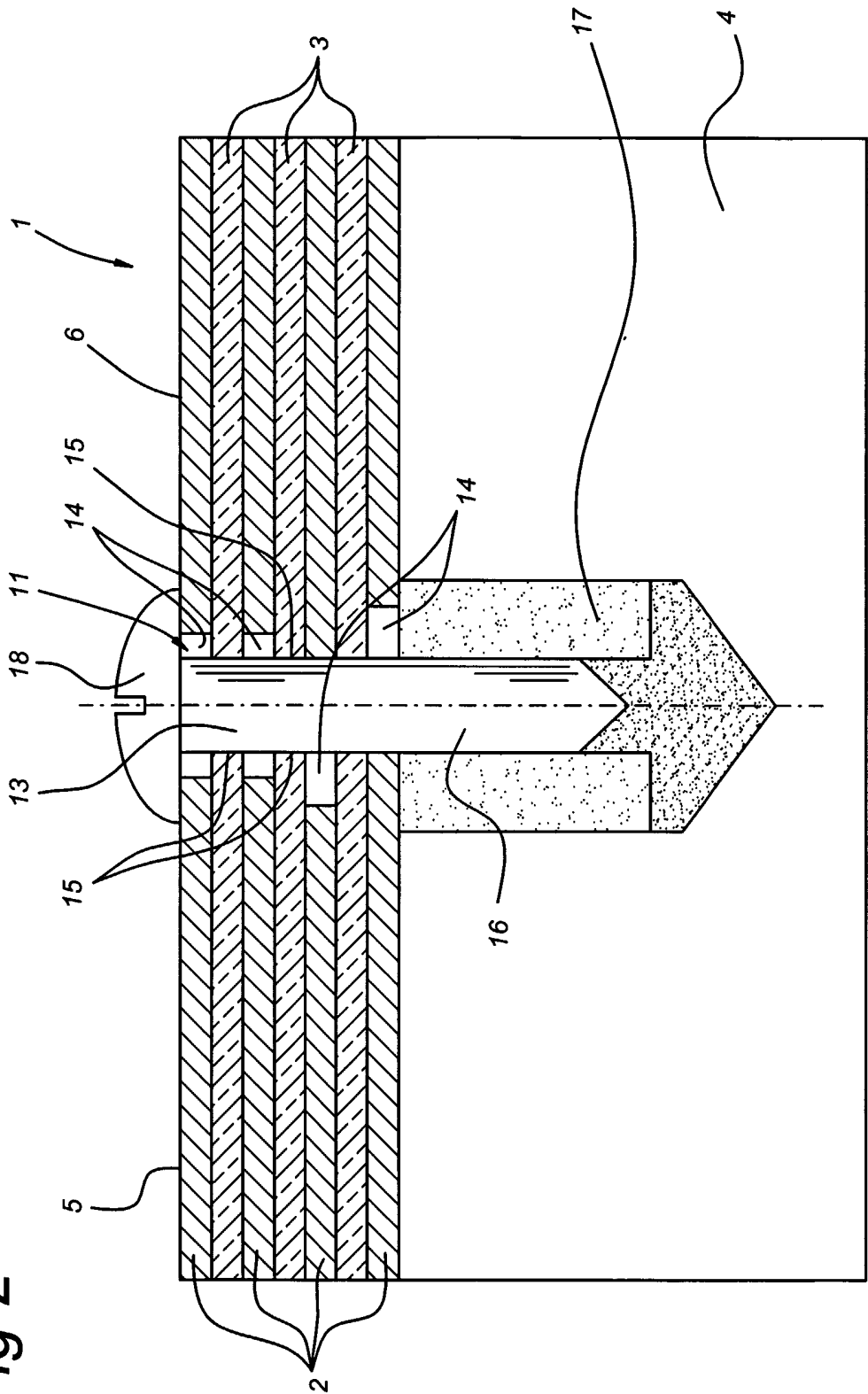

Fig 2

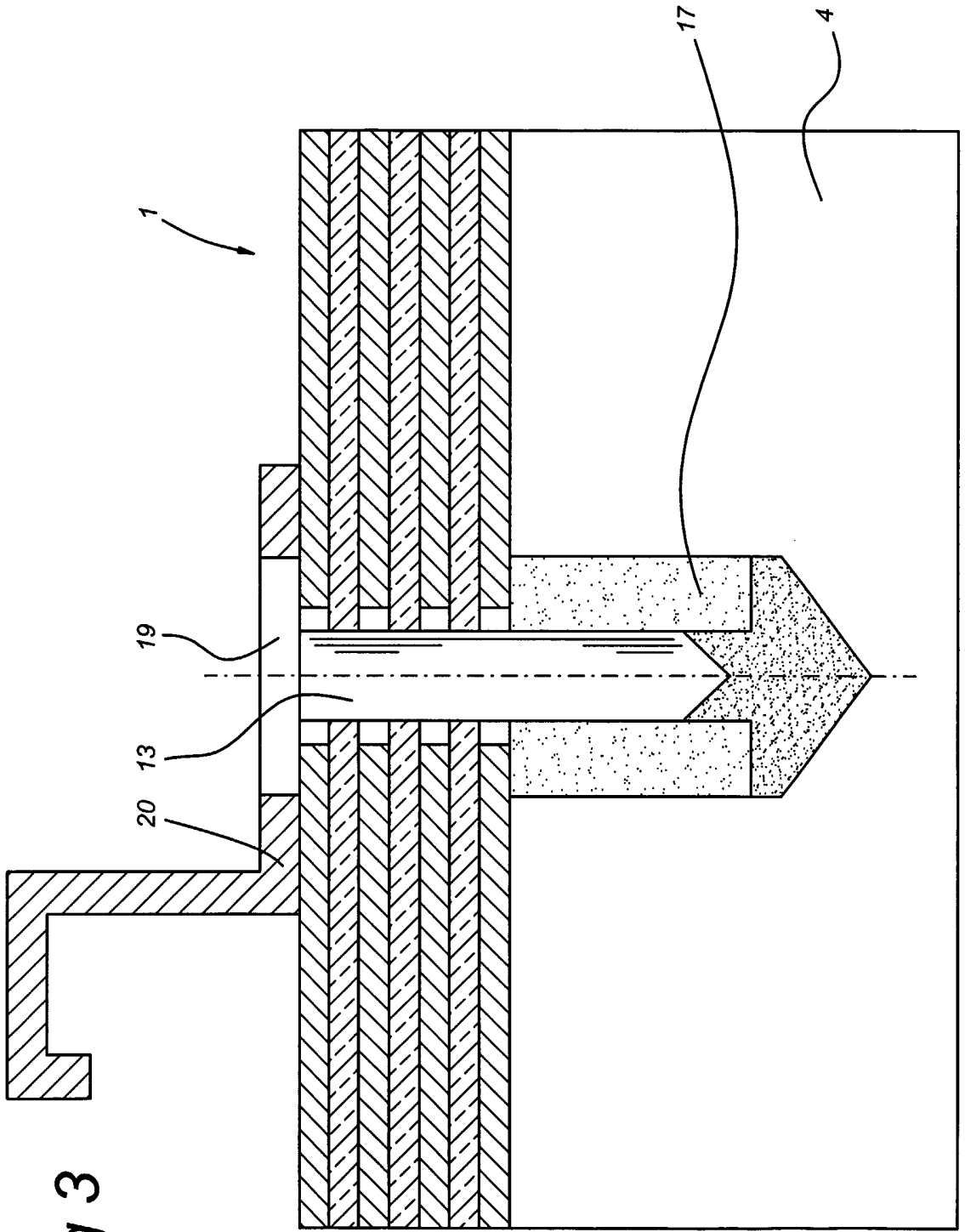
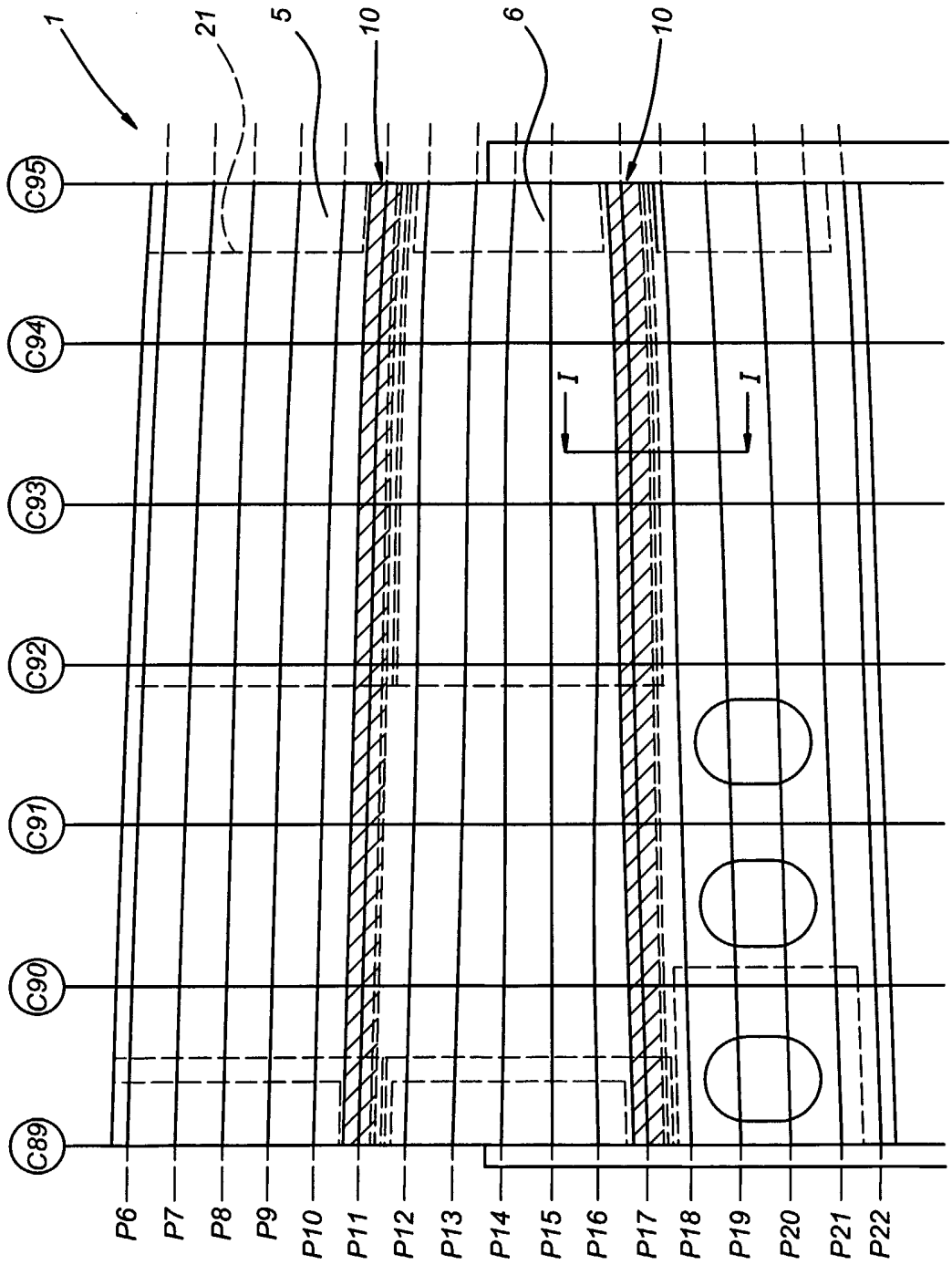

Fig 4



## INTERNATIONAL SEARCH REPORT

onal Application No  
PCT/NL 02/00515

## A. CLASSIFICATION OF SUBJECT MATTER

IPC 7 B32B31/00 B32B15/08 B32B1/10 B29C70/88 B29C70/44

According to International Patent Classification (IPC) or to both national classification and IPC

## B. FIELDS SEARCHED

Minimum documentation searched (classification system followed by classification symbols)

IPC 7 B32B B29C

Documentation searched other than minimum documentation to the extent that such documents are included in the fields searched

Electronic data base consulted during the international search (name of data base and, where practical, search terms used)

EPO-Internal, WPI Data, PAJ

## C. DOCUMENTS CONSIDERED TO BE RELEVANT

Category °	Citation of document, with indication, where appropriate, of the relevant passages	Relevant to claim No.
X	DE 41 18 814 A (HITACHI LTD ;HATAMURA YOTARO (JP)) 19 December 1991 (1991-12-19) column 3, line 59 -column 4, line 24; claim 11; figure 1 column 1	1,3,7,9
T	A. VLOT ET AL: "Towards Application of Fibre Metal Laminates in Large Aircraft" , WWW.GLARECONFERENCE.COM , 9-2001 XP002195138 paragraph '0007! - paragraph '0008!; figure 17	1-10
A	EP 1 103 370 A (EADS AIRBUS GMBH) 30 May 2001 (2001-05-30) the whole document	1-10

Further documents are listed in the continuation of box C.

Patent family members are listed in annex.

° Special categories of cited documents :

- \*A\* document defining the general state of the art which is not considered to be of particular relevance
- \*E\* earlier document but published on or after the international filing date
- \*L\* document which may throw doubts on priority claim(s) or which is cited to establish the publication date of another citation or other special reason (as specified)
- \*O\* document referring to an oral disclosure, use, exhibition or other means
- \*P\* document published prior to the international filing date but later than the priority date claimed

- \*T\* later document published after the international filing date or priority date and not in conflict with the application but cited to understand the principle or theory underlying the invention
- \*X\* document of particular relevance; the claimed invention cannot be considered novel or cannot be considered to involve an inventive step when the document is taken alone
- \*Y\* document of particular relevance; the claimed invention cannot be considered to involve an inventive step when the document is combined with one or more other such documents, such combination being obvious to a person skilled in the art.
- \*&\* document member of the same patent family

Date of the actual completion of the international search

22 October 2002

Date of mailing of the international search report

04/11/2002

Name and mailing address of the ISA

European Patent Office, P.B. 5818 Patentlaan 2  
NL - 2280 HV Rijswijk  
Tel. (+31-70) 340-2040, Tx. 31 651 epo nl,  
Fax: (+31-70) 340-3016

Authorized officer

Van Wallene, A

**INTERNATIONAL SEARCH REPORT**  
 nformation on patent family members

nal Application No  
**PCT/NL 02/00515**

Patent document cited in search report	Publication date	Patent family member(s)	Publication date
DE 4118814	A	19-12-1991	JP 4043020 A 13-02-1992
			DE 4118814 A1 19-12-1991
			KR 9403719 B1 28-04-1994
<hr/>			
EP 1103370	A	30-05-2001	DE 19956394 A1 13-06-2001
			EP 1103370 A1 30-05-2001
			US 6460240 B1 08-10-2002
<hr/>			