



(51) International Patent Classification:

B23K 26/18 (2006.01) *H01S 3/10* (2006.01)
B23K 26/36 (2006.01) *B23K 103/10* (2006.01)
B23K 26/04 (2006.01)

(21) International Application Number:

PCT/US2011/027946

(22) International Filing Date:

10 March 2011 (10.03.2011)

(25) Filing Language:

English

(26) Publication Language:

English

(71) Applicant (for all designated States except US): **ELECTRO SCIENTIFIC INDUSTRIES, INC.** [US/US]; 13900 NW Science Park Drive, Portland, Oregon 97229 (US).

(72) Inventors; and

(75) Inventors/Applicants (for US only): **ZHANG, Haibin** [CA/US]; 905 SW Cedar Hills Blvd., Apt 1329, Portland, Oregon 97225 (US). **SIMENSON, Glenn** [US/US]; 925 SW 78th Ave., Portland, Oregon 97225 (US). **LEONARD, Patrick** [US/US]; 3777 Greenook Blvd., Ann Arbor, Michigan 48103 (US).

(74) Agent: **LEONARD, Patrick**; Electro Scientific Industries, 13900 NW Science Park Drive, Portland, Oregon 97229 (US).

(81) Designated States (unless otherwise indicated, for every kind of national protection available):

AE, AG, AL, AM, AO, AT, AU, AZ, BA, BB, BG, BH, BR, BW, BY, BZ, CA, CH, CL, CN, CO, CR, CU, CZ, DE, DK, DM, DO, DZ, EC, EE, EG, ES, FI, GB, GD, GE, GH, GM, GT, HN, HR, HU, ID, IL, IN, IS, JP, KE, KG, KM, KN, KP, KR, KZ, LA, LC, LK, LR, LS, LT, LU, LY, MA, MD, ME, MG, MK, MN, MW, MX, MY, MZ, NA, NG, NI, NO, NZ, OM, PE, PG, PH, PL, PT, RO, RS, RU, SC, SD, SE, SG, SK, SL, SM, ST, SV, SY, TH, TJ, TM, TN, TR, TT, TZ, UA, UG, US, UZ, VC, VN, ZA, ZM, ZW.

(84) Designated States (unless otherwise indicated, for every kind of regional protection available):

ARIPO (BW, GH, GM, KE, LR, LS, MW, MZ, NA, SD, SL, SZ, TZ, UG, ZM, ZW), Eurasian (AM, AZ, BY, KG, KZ, MD, RU, TJ, TM), European (AL, AT, BE, BG, CH, CY, CZ, DE, DK, EE, ES, FI, FR, GB, GR, HR, HU, IE, IS, IT, LT, LU, LV, MC, MK, MT, NL, NO, PL, PT, RO, RS, SE, SI, SK, SM, TR), OAPI (BF, BJ, CF, CG, CI, CM, GA, GN, GQ, GW, ML, MR, NE, SN, TD, TG).

Published:

— with international search report (Art. 21(3))

(54) Title: METHOD AND APPARATUS FOR RELIABLY LASER MARKING ARTICLES

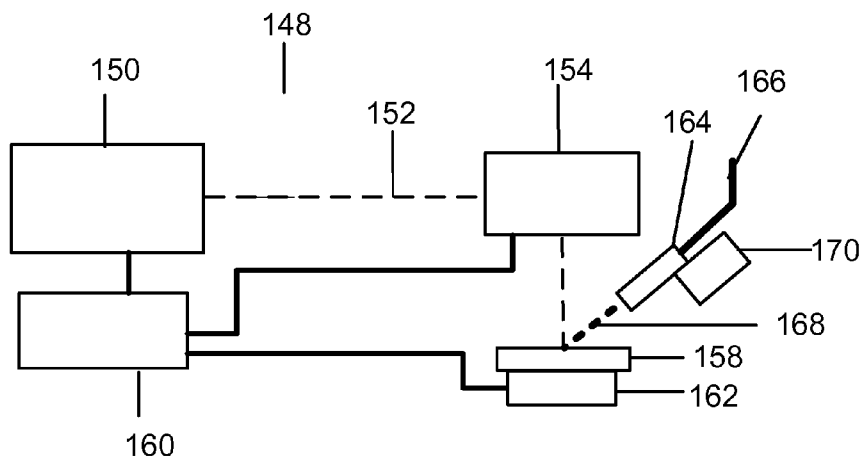

Fig. 13

(57) Abstract: The invention is a method and apparatus for creating marks 194 on an anodized aluminum specimen 190 with selectable color and optical density. The method includes providing a laser marking system 148 having a laser 150, laser optics 154 and a controller 160 operatively connected to said laser 150 to control laser pulse parameters. The laser marking system 148 is directed to produce laser pulses 152 having laser pulse parameters associated with the desired color and optical density in the presence of a fluid 168 directed to the surface of the anodized aluminum specimen 158 while marking.

WO 2012/121734 A1

METHOD AND APPARATUS FOR RELIABLY LASER MARKING ARTICLES

[0001] Continuation in Part of Application No. 12/704,293 filed on Feb. 11, 2010.

Technical Field

[0002] The present invention relates to laser marking of anodized articles with a laser processing system. More particularly it relates to marking anodized articles in a durable and commercially desirable fashion with a laser processing system. Specifically it relates to characterizing the interaction between ultraviolet, visible and infrared wavelength laser pulses and the anodized articles to reliably and repeatably create durable marks with a desired color and optical density in the presence of a fluid.

Background of the Invention

[0003] Marketed products commonly require some type of marking on the product for commercial, regulatory, cosmetic or functional purposes. Desirable attributes for marking include consistent appearance, durability, and ease of application. Appearance refers to the ability to reliably and repeatably render a mark with a selected shape, color and optical density. Durability is the quality of remaining unchanged in spite of abrasion to the marked surface. Ease of application refers to the cost in materials, time and resources of producing a mark including programmability. Programmability refers to the ability to program the marking device with a new pattern to be marked by changing software as opposed to changing hardware such as screens or masks.

[0004] Anodized metallic articles, which are lightweight, strong, easily shaped, and have a durable surface finish, have many applications in industrial and commercial goods. Anodization describes any one of a number of electrolytic passivation processes in which a natural oxide layer is increased on metals such as

aluminum, titanium, zinc, magnesium, niobium or tantalum in order to increase resistance to corrosion or wear and for cosmetic purposes. These surface layers can be colored or dyed virtually any color, making a permanent, colorfast, durable surface on the metal. Many of these metals can be advantageously marked using aspects of the instant invention. In addition, metals such as stainless steel which resist corrosion can be marked in this fashion. Many articles manufactured out of metals such these as are in need of permanent, visible, commercially desirable marking. Anodized aluminum is an exemplary material that has such needs. Marking anodized aluminum with laser pulses produced by a laser processing system can make durable marks quickly at extremely low cost per mark in a programmable fashion.

[0005] Creating color changes on the surface of anodized aluminum with laser pulses has been known for several years. An article titled "Dry laser cleaning of anodized aluminum" by P. Maja, M. Autric, P. Delaporte, P. Alloncle, COLA'99 – 5th International Conference on Laser Ablation, July 19–23, 1999, Göttingen, Germany, published in Appl. Phys. A 69 [Suppl.], S343–S346 (1999), pp S43-S346, describes removing anodization from aluminum surfaces, however, note is taken of color changes which occur at laser energies below that required for removal of anodization from the surface.

[0006] One mechanism which has been put forth to explain the change in optical density or color of metallic surfaces is the creation of laser-induced periodic surface structures (LIPSS). The article "Colorizing metals with femtosecond laser pulses" by A. Y. Vorobyev and Chunlei Guo, Applied Physics Letters 92, (041914) 2008, pp 41914-1 to 141914-3 describes various colors which may be created on aluminum or aluminum-like metals using femtosecond laser pulses. This article describes making black or gray marks on metal and creating a gold color on metal. Some other colors are mentioned but no further description is made. LIPSS is the only explanation offered for the creation of marks on metallic surfaces. Further, only laser pulses having temporal pulse widths of 65 femtoseconds are taught or suggested to create these structures. In addition, no mention is made as to whether the aluminum samples are anodized or have had the surface cleaned prior to laser processing. Further the article does not discuss possible damage to the oxide layer.

[0007] When discussing laser pulse duration, the method of measuring pulse duration should be defined. Temporal pulse shape can range from simple Gaussian

pulses to more complex shapes depending upon the task. Exemplary non-Gaussian laser pulses advantageous for certain types of processing are described in US Patent No. 7,126,746 GENERATING SETS OF TAILORED LASER PULSES, inventors Sun et al., which patent has been assigned to the assignees of the instant invention and is hereby incorporated by reference. This patent discloses methods and apparatus to create laser pulses with temporal profiles that vary from the typical Gaussian temporal profiles produced by diode pumped solid state (DPSS) lasers. These non-Gaussian pulses are called "tailored" pulses because their temporal profile is altered from the typical Gaussian profile by combining more than one pulse to create a single pulse and/or modulating the pulse electro-optically. This creates a pulse which the pulse energy varies as a function of time, often including one or more power peaks wherein the instantaneous power increases to a value greater than the average power of the pulse for a fraction of the pulse duration. This type of tailored pulse can be effective in processing materials at high rates without causing problems with debris or excessive heating of surrounding material. An issue is that measuring the duration of complex pulses such as these using standard methods typically applied to Gaussian pulses can yield anomalous results. Gaussian pulse durations are typically measured using the full width at half maximum (FWHM) measure of duration. In contrast to this, using the integral square method, as described in US Patent No. 6,058,739 LONG LIFE FUSED SILICA ULTRAVIOLET OPTICAL ELEMENTS, inventors Morton et al., allows complex pulse temporal shapes to be measured and compared in a more meaningful manner. In this patent, pulse duration is measured using the formula

$$t = \frac{\left(\int T(t) dt \right)^2}{\int T^2(t) dt}$$

where $T(t)$ is a function which represents the temporal shape of the laser pulse.

[0008] Another problem with reliably and repeatably producing marks with desired color and optical density in anodized aluminum is that the energy required to create very dark marks with readily available nanosecond pulse width solid state lasers is

enough to cause damage to the anodization, an undesirable result. "Darkness" or "lightness" or color names are relative terms. A standard method of quantifying color is by reference to the CIE system of colorimetry. This system is described in "CIE Fundamentals for Color Measurements", Ohno, Y., IS&T NIP16 Conf, Vancouver, CN, Oct. 16-20, 2000, pp 540-545. In this system of measurement, achieving a commercially desirable black mark requires parameters less than or equal to $L^*=40$, $a^*=5$, and $b^*=10$. This results in a neutral colored black mark with no visible grayness or coloration. In US Patent No. 6,777,098 MARKING OF AN ANODIZED LAYER OF AN ALUMINIUM OBJECT, inventor Keng Kit Yeo describes a method of marking anodized aluminum articles with black marks which occur in a layer between the anodization and the aluminum and therefore are as durable as the anodized surface. The marks described therein are described as being dark grey or black in hue and somewhat less shiny than unmarked portion using nanosecond range infrared laser pulses. In addition, the aluminum is required to be cleaned of all surface particles, for instance particles remaining after polishing, prior to anodization. Making marks according to the methods claimed in this patent are disadvantageous for two reasons: first, creating commercially desirable black marks with nanosecond-range pulses tends to cause destruction of the oxide layer and secondly, cleaning of the aluminum following polishing or other processing adds another step in the process, with associated expense, and possibly disturbs a desired surface finish by further processing.

[0009] What is desired but undisclosed by the art is a reliable and repeatable method of making marks on anodized aluminum in both black or grey or in color that does not require an expensive femtosecond laser or disturb the oxide layer in the process or require cleaning following surface preparation. In addition, no information is supplied on how to repeatably create various colors on anodized aluminum surfaces, nor has the effects of bleaching or damage to the anodization layer been thoroughly investigated. What is needed then is a method for reliably and repeatably creating marks having a desired optical density or grayscale and color on anodized aluminum using a lower cost laser, without causing undesired damage to the overlaying oxide or requiring cleaning prior to anodization.

Summary of the Invention

[0010] An aspect of this invention is to mark anodized aluminum articles with visible marks of various optical densities or grayscale and colors. These marks should be durable and have commercially desirable appearance. This is achieved by using laser pulses to create the marks. These marks are created at the surface of the aluminum underneath the oxide layer and are therefore protected by the oxide. The laser pulses create commercially desirable marks without causing significant damage to the oxide layer, thereby making the marks durable. Durable, commercially desirable marks are created on anodized aluminum by controlling the laser parameters with which create and direct laser pulses. In one aspect of this invention a laser processing system is adapted to produce laser pulses with appropriate parameters in a programmable fashion. Using a fluid flow while laser marking inhibits thermal damage in the oxide layer during marking, permitting higher energies to be used which yield greater range of colors and optical densities and higher throughput.

[0011] Exemplary laser pulse parameters which may be selected to improve the reliability and repeatability of laser marking anodized aluminum include laser type, wavelength, pulse duration, pulse repetition rate, number of pulses, pulse energy, pulse temporal shape, pulse spatial shape and focal spot size and shape. Additional laser pulse parameters include specifying the location of the focal spot relative to the surface of the article and directing the relative motion of the laser pulses with respect to the article.

[0012] Aspects of this invention create durable, commercially desirable marks by darkening the surface of the aluminum beneath the anodization with optical densities which range from nearly undetectable with the unaided eye to black depending upon the particular laser pulse parameters employed. Other aspects of this invention create colors in various optical densities in shades of tan or gold, likewise depending upon the particular laser pulse parameters employed. Other aspects of this invention create durable, commercially desirable marks on anodized aluminum by bleaching or partially bleaching dyed or colored anodization with or without marking the aluminum beneath. Other aspects use a fluid flow during laser processing to reduce oxide damage.

[0013] To achieve the foregoing with these and other aspects in accordance with the purposes of the present invention, as embodied and broadly described herein, a method for creating a color and optical density selectable visible mark on an

anodized aluminum specimen and apparatus adapted to perform the method is disclosed herein. The invention is a method and apparatus for creating a color and optical density selectable visible mark on an anodized aluminum specimen. The method includes providing a laser marking system having a laser, laser optics and a controller operatively connected to said laser to control laser pulse parameters and a controller with stored laser pulse parameters, selecting the stored laser pulse parameters associated with the desired color and optical density, directing the laser marking system to produce laser pulses having laser pulse parameters associated with the desired color and optical density while directing a fluid flow at the article being marked.

Brief Description of the Drawings

- Fig 1. Laser processing system
- Fig 2. Mark made with prior art nanosecond pulses
- Fig 3. Mark made with picosecond pulses
- Fig 4. Beam waist
- Fig 5. Grayscale marks on anodized aluminum
- Fig 6. Marks on anodized aluminum
- Fig 7. Dyed, visible marked anodized aluminum
- Fig 8. Dyed, IR marked anodized aluminum
- Fig 9. Graph showing visible laser pulse thresholds
- Fig 10. Graph showing IR laser pulse thresholds
- Fig 11. Image data converted to laser parameters
- Fig 12a-i Color anodization being applied to an aluminum article
- Fig 13. Laser marking system with fluid flow
- Fig 14a. Anodization bleaching showing cracking
- Fig 14b. Anodization bleaching showing no cracking with fluid

Detailed Description of Preferred Embodiments

[0014] Aspects of this invention mark anodized aluminum articles with visible marks of various optical densities and colors, durably, selectably, predictably, and repeatably. It is advantageous for these marks to appear on or near the surface of

the aluminum and leave the anodization layer substantially intact to protect both the surface and the marks. Marks made in this fashion are referred to as interlayer marks since they are made at or on the surface of the aluminum beneath the oxide layer that forms the anodization. Ideally the oxide remains intact following marking in order to protect the marks and provide a surface that is mechanically contiguous between adjacent marked and non-marked regions. Further, these marks should be able to be produced reliably and repeatably, meaning that if a mark with a specific color and optical density is desired, a set of laser parameters is known which will produce the desired result when the anodized aluminum is processed by a laser processing system. It is also contemplated that some such marks created with a laser processing system be invisible. In this aspect, the laser processing system creates marks which are not visible under ordinary viewing conditions, but which become visible under other conditions, for example when illuminated by ultraviolet light. It is contemplated that these marks be used to provide anti-theft marking or other special marks.

[0015] An embodiment of the instant invention uses an adapted laser processing system to mark anodized aluminum articles. An exemplary laser processing system which can be adapted to mark anodized aluminum articles is the ESI MM5330 micromachining system, manufactured by Electro Scientific Industries, Inc., Portland, OR 97229. This system is a micromachining system employing a diode-pumped Q-switched solid state laser with an average power of 5.7 W at 30 K Hz pulse repetition rate, second harmonic doubled to 532 nm wavelength. Another exemplary laser processing system which may be adapted to mark anodized aluminum articles is the ESI ML5900 micromachining system, also manufactured by Electro Scientific Industries, Inc., Portland, OR 97229. This system employs a solid state diode-pumped laser which can be configured to emit wavelengths from about 355 nm (UV) to about 1064 nm (IR) at pulse repetition rates up to 5 MHz. Either system may be adapted by the addition of appropriate laser, laser optics, parts handling equipment and control software to reliably and repeatably produce marks in anodized aluminum surfaces according to the methods disclosed herein. These modifications permit the laser processing system to direct laser pulses with the appropriate laser parameters to the desired places on an appropriately positioned and held anodized aluminum article at the desired rate and pitch to create the desired mark with desired color and optical density. A diagram of such an adapted system is shown in Fig 1.

[0016] Fig 1 shows a diagram of an ESI MM5330 micromachining system adapted for marking articles according to an embodiment of the instant invention. Adaptations include the laser 10, which, in an embodiment of this invention is a diode pumped Nd:YVO₄ solid state laser operating at 1064 nm wavelength, model Rapid manufactured by Lumera Laser GmbH, Kaiserslautern, Germany. This laser is optionally frequency doubled using a solid state harmonic frequency generator to reduce the wavelength to 532 nm or tripled to about 355 nm, thereby creating visible (green) or ultraviolet (UV) laser pulses, respectively. This laser 10 is rated to produce 6 Watts of continuous power and has a maximum pulse repetition rate of 1000 KHz. This laser 10 produces laser pulses 12 with duration of 1 picosecond to 1,000 nanoseconds in cooperation with controller 20. These laser pulses 12 may be Gaussian or specially shaped or tailored by the laser optics 14 to permit desired marking. The laser optics 14, in cooperation with the controller 20, direct laser pulses 12 to form a laser spot 16 on or near article 18. Article 18 is fixtured upon stage 22, which includes motion control elements which, in cooperation with the controller 20 and laser optics 14 provides compound beam positioning capability. Compound beam positioning is the capability to mark shapes on an article 18 while the article 18 is in relative motion to the laser spot 16 by having the controller 20 direct steering elements in the laser optics 14 to compensate for the relative motion induced by motion of the stage 22, the laser spot 16 or both.

[0017] The laser pulses 12 are also shaped by the laser optics 14 in cooperation with controller 20, as they are directed to form a laser spot 16 on or near article 18. The laser optics 14 directs the laser pulses' 12 spatial shape, which may be Gaussian or specially shaped. For example, a "top hat" spatial profile may be used which delivers a laser pulse 12 having an even dose of radiation over the entire spot which impinges the article being marked. Specially shaped spatial profiles such as this may be created using diffractive optical elements. Laser pulses 12 also may be shuttered or directed by electro-optical elements, steerable mirror elements or galvanometer elements of the laser optics 14.

[0018] The laser spot 16 refers to the focal spot of the laser beam formed by the laser pulses 12. As mentioned above the distribution of laser energy at the laser spot 16 depends upon the laser optics 14. In addition the laser optics 14 control the depth of focus of the laser spot 16, or how quickly the spot goes out of focus as the plane of measurement moves away from the focal plane. By controlling the depth of

focus, the controller 20 can direct the laser optics 14 and the stage 22 to position the laser spot 16 either at or near the surface of the article 18 repeatably with high precision. Making marks by positioning the focal spot above or below the surface of the article allows the laser beam to defocus by a specified amount and thereby increase the area illuminated by the laser pulse and decrease the laser fluence at the surface. Since the geometry of the beam waist is known, precisely positioning the focal spot above or below the actual surface of the article will provide additional precision control over the spot size and fluence.

[0019] Fig 2 is a microphotograph showing a mark created on anodized aluminum 30 using prior art laser with greater than one nanosecond pulses without fluid flow. The anodization shows clear signs of cracking 32 in the mark area 34, an undesirable result. Fig 3 shows the same color and optical density mark 38 on the same type of anodized aluminum 36 made with a picosecond laser showing no cracking. Picosecond lasers mark anodized aluminum articles with a commercially desirable black without causing damage to the oxide layer. Commercially acceptable black is defined as a mark having CIE chromaticity of $L^*=40$, $a^*=5$, and $b^*=10$ or less. Another advantage of using picosecond lasers is that they are much less expensive, require much less maintenance, and typically have much longer operating lifetimes than prior art femtosecond lasers. In addition, aspects of the instant invention do not require cleaning of the aluminum surface prior to anodization to create commercially desirable marks.

[0020] An embodiment of the instant invention performs marking on anodized aluminum under the anodization. For the interlayer marking to happen, the laser fluence, defined by:

$$F = E / s$$

where E is laser pulse energy and s is the laser spot area, must satisfy

$$F_u < F < F_s$$

where F_u is the laser modification threshold of the substrate/coating interface, aluminum/aluminum oxide in this case, and F_s is the damaging threshold for the surface layer, or anodization. F_u and F_s have been obtained by experiments and

represent the fluence of the selected laser at which the substrate and surface layer start to get damaged. For 10 ps pulses, our experiments show that F_u for Al is $\sim 0.13 \text{ J/cm}^2$ for ps green and $\sim 0.2 \text{ J/cm}^2$ for ps IR, and the F_s is $\sim 0.18 \text{ J/cm}^2$ for ps green and $\sim 1 \text{ J/cm}^2$ for ps IR. Varying the laser fluence between these values creates marks of varying color and optical density. Different pulse durations and laser wavelengths would each have corresponding values of F_u and F_s . The actual thresholds for a given set of laser parameters and anodized article are determined experimentally. The advantage of using a fluid flow while marking is that the fluid flow increases the damage threshold F_s thereby permitting higher energies to be used to mark the articles which permits higher throughput and a wider range of marking densities.

[0021] An embodiment of this invention precisely controls the laser fluence at the surface of the aluminum article by adjusting the location of the laser spot from being on the surface of the aluminum article to being located a precise distance above or below the surface of the aluminum. Fig 4 shows a diagram of a laser pulse focal spot 40 and the beam waist in its vicinity. The beam waist is represented by a surface 42 which is the diameter of the spatial energy distribution of a laser pulse as measured by the FWHM method on the optical axis 44 along which the laser pulses travel. The diameter 48 represents the laser pulse spot size on the surface of the aluminum when the laser processing system focuses the laser pulse at a distance (A-O) above the surface. Diameter 46 represents the laser pulse spot size on the surface of the aluminum when the laser processing system focuses the laser pulses at a distance (O-B) below the surface.

[0022] In addition to commercially desirable black, marking articles with grayscale values is also useful. Figs 5 and 6 show a series of grayscale marks made on anodized aluminum made by an embodiment of this invention. The optical density of the marks range from nearly indistinguishable from the background to fully black. According to an aspect of the instant invention, each grayscale mark can be identified by a unique triplet of CIE colorimetry values. L^* , a^* and b^* . An aspect of the instant invention associates each desired grayscale value with a set of laser parameters that reliably and repeatably produce the desired grayscale value mark on anodized aluminum upon command. Note also that the marks which may seem indistinguishable to the naked eye can become visible when illuminated with other than broad spectrum visible light, for example ultraviolet light.

[0023] Fig 5 shows black marks 60, 62, 64, and 66 made on anodized aluminum 70 by an embodiment of this invention. These marks 60, 62, 64, and 66 have CIE chromaticities ranging from less than $L^*=40$, $a^*=5$ and $b^*=10$, to totally transparent making them commercial desirable marks. Another feature of these marks is that since they are underneath undamaged anodization, they have uniform appearance over a wide range of viewing angles. Marks made using prior art methods tend to have wide variation in appearance depending upon viewing angle due to damage to the anodization layer. In particular, when marking with prior art nanosecond pulses, applying enough laser pulse energy to the surface to make dark marks causes damage to the anodization which causes the appearance of the marks to change with viewing angle. Marks made by an aspect of the instant invention do not damage anodization regardless of how dark the marks are, nor do they change in appearance with viewing angle. These improved marks were made with the following laser parameters:

| | |
|----------------|--------------------------|
| Laser Type | DPSS Nd:YVO ₄ |
| Wavelength | 532 nm |
| Pulse duration | 10 ps |
| Pulse temporal | Gaussian |
| Laser power | 4W |
| Rep Rate | 500 KHz |
| Speed | 25 mm/s |
| Pitch | 10 microns |
| Spot size | 10-400 microns |
| Spot shape | Gaussian |
| Focal Height | 0-5 mm with 0.5 mm step |

Table 1. Laser parameters for color and grayscale marking

[0024] The marks 60, 62, 64, 66 range in optical density from virtually unnoticeable 60 against the unmarked aluminum to full black 62. Grayscale optical densities 64, 66 between the two extremes are created by moving the focal spot closer to the article, increasing the fluence and thereby creating darker marks. The height of the focal spot above the surface of the aluminum varies from zero, in the

case of the darkest optical density mark 62, increasing by 500 micron increments for each mark 64, 66 from right to left in Fig 5, ending at 5 mm above the surface for the lightest mark 60. Note that marks 64 created with focal spot located 4.5 to 1.5 mm above the surface of the aluminum show tan or golden colors and marks created with focal spot one mm 62 and 66 or less appear gray or black. Maintaining this precise control over the laser focal spot distance from the work surface in addition to maintaining other laser parameters within normal laser processing tolerances permits laser marks with desired color and optical density to be made on anodized aluminum. In addition, the darkest mark exhibits a CIE chromaticity of less than $L^*=40$, $a^*=5$, and $b^*=10$, making it a commercially desirable black mark.

[0025] Another aspect of the instant invention determines the relationship between marks with colors other than grayscale and picosecond laser pulse parameters. Colors other than grayscale can be produced on anodized aluminum in two different ways. In the first, a gold tone can be produced in a range of optical densities. This color is produced by changes made at the interface between the aluminum and the oxide coating. Careful choice of laser pulse parameters will produce the desired golden color without damaging the oxide coating. Fig 5 also shows various shades of gold or tan created by an aspect of the instant invention.

[0026] Laser marking of anodized aluminum can also be achieved by an aspect of the instant invention which uses IR wavelength laser pulses to mark the aluminum. This aspect creates marks of varying grayscale densities by varying the laser fluence at the surface of the aluminum in two different manners. As discussed above, grey scale can be achieved by varying the fluence at the surface by positioning the focal spot above or below the surface of the aluminum. The second manner of controlling grey scale is to vary the total dose at the surface of the aluminum by changing the bite sizes or line pitches when marking the desired patterns. Changing bite sizes refers to adjusting the rate at which the laser pulse beam is moved relative to the surface of the aluminum or changing the pulse repetition rate or both, which results in changing the distance between successive laser pulse impact sites on the aluminum. Varying line pitches refers to adjusting the distance between marked lines to achieve various degrees of overlapping. Fig 6 shows an aluminum article 74 with an array of marks 72. These marks 72 are arranged in an array of six columns and four rows. The six columns represent six Z-heights of the focal spot above the surface of the aluminum ranging from 0 (top row)

to 5 mm (bottom row). The four rows represent pitches of 5, 10, 20 and 50 microns reading from top to bottom. As can be seen from Fig 6, varying the Z-height of the focal spot and varying the pitch of the laser pulses can predictably produce graylevels of any desired optical density from less than CIE $L^*=40$, $a^*=5$, and $b^*=10$ to nearly transparent, thereby producing commercially desirable marks on anodized aluminum.

| | |
|----------------|--------------------------|
| Laser Type | DPSS Nd:YVO ₄ |
| Wavelength | 1064 nm |
| Pulse duration | 10 ps |
| Pulse temporal | Gaussian |
| Laser power | 2.5 W |
| Rep Rate | 500 KHz |
| Speed | 50 mm/s |
| Pitch | 5, 10, 20, 50microns |
| Spot size | 55-130 microns |
| Spot shape | Gaussian |
| Focal Height | 0-5 mm with 1 mm step |

Table 2. Laser pulse parameters for grayscale IR marking

[0027] A second type of marking which may be applied to anodized aluminum using picosecond laser pulses is alterations in color contrast caused by bleaching of dyed anodization. On a microscopic scale, anodization is porous, and will readily accept dyes of many types. Referring again to Fig 3, this microphotograph of anodized aluminum shows the porous nature of surface. Laser pulses used to mark dyed anodized aluminum can, depending upon the wavelength and pulse energy, bleach the dye as it marks the aluminum, making the anodization transparent and thereby reveals the marks on the aluminum underneath. With higher fluence, simultaneous dye bleaching and marking of the aluminum beneath the anodization layer with black, grey scale, or colors presented in previous section is possible. Less energetic pulses can partially bleach the anodization dyes rendering it

translucent and thereby partially coloring the underlying aluminum marks. Finally, longer wavelength pulses can mark the aluminum with commercially desirable black or grey scale colors without bleaching the anodization. Fig 7 shows a dyed anodized aluminum article with marks made with visible (532 nm) laser pulses. Note that the dye in the anodization is bleached in the areas subjected to laser pulses. Fig 8 shows the same type of dyed anodized aluminum article with marks made with IR (1064 nm) laser pulses. Note that the anodization is not bleached by the IR laser pulses and therefore does not reveal the aluminum color beneath beyond the translucency of the original oxide.

[0028] Another aspect of this invention relates to laser marking anodized aluminum with colored anodization using picosecond lasers. Since anodization typically forms a porous surface, dyes can be introduced which alter the appearance of the aluminum. These dyes can either be opaque or translucent, allowing varying amounts of incident light to reach the aluminum and be reflected back through the anodization. Fig 7 shows an anodized aluminum article 80 with pink dye in the anodization and an array of marks 82 produced according to an aspect of the instant invention. Colors are created by bleaching the dye in the oxide layer as the aluminum underneath showed native (silver) color to a range of laser-marked colors from shades of tan, to gray and finally black. These shades are created by varying the fluence of the laser pulses at the surface of the aluminum. The four rows represent varying the pitch of the laser pulses from 10 to 50 microns and the columns represent varying the focal spot distance from the surface from 0.0 to 5.0 mm. These laser parameters in all cases bleach the dye in the oxide overlaying the aluminum allowing the marks on the aluminum to show through. The laser marks optical density range from transparent to CIE chromaticity less than $L^*=40$, $a^*=5$, $b^*=10$. Laser parameters used to create these marks are given in Table 3.

| | |
|----------------|--------------------------|
| Laser Type | DPSS Nd:YOV ₄ |
| Wavelength | 532 nm |
| Pulse duration | 10 ps |
| Pulse temporal | Gaussian |
| Laser power | 4W |
| Rep Rate | 500 KHz |

| | |
|--------------|----------------|
| Speed | 50 mm/s |
| Pitch | 10 microns |
| Spot size | 10-400 microns |
| Spot shape | Gaussian |
| Focal Height | 0-5 mm |

Table 3. Laser parameters for visible oxide bleaching

[0029] Bleaching of anodization dye is frequency dependent. As shown in Fig 7, 532 nm laser pulses bleach anodization dye even at the lowest fluence. IR laser wavelengths, on the other hand, create marks on dyed anodized aluminum without bleaching the dye for most translucent dye colors. Fig 8 shows an anodized aluminum article 100 with pink dye with marks 102 made with IR laser pulses. The marks range from translucent to black and were made by altering the laser fluence by both changing the distance from the focal spot to the surface and by changing the pitch. The six columns represent changing the distance between the focal spot of the laser pulses and the surface of the aluminum from 5.5 mm (right) to zero (left). The four rows represent changing the laser pulse pitch from 10 to 50 microns. Laser parameters used to create these marks is shown in Table 4.

| | |
|----------------|--------------------------|
| Laser Type | DPSS Nd:YOV ₄ |
| Wavelength | 1064 nm |
| Pulse duration | 10 ps |
| Pulse temporal | Gaussian |
| Laser power | 4W |
| Rep Rate | 500 KHz |
| Speed | 50 mm/s |
| Pitch | 10 microns |
| Spot size | 10-400 microns |
| Spot shape | Gaussian |
| Focal Height | 0-5 mm |

Table 4. Laser parameters for IR colored anodization marking

[0030] The relationship between bleaching anodization dye, marking aluminum and causing surface ablation for 532 nm (green) laser wavelengths is shown in Fig 9. For 532 nm (green) laser pulses with parameters within those given in Tables 1 and 3, Fig 8 shows the fluence thresholds in Joules/cm² for bleaching anodization (F_b), marking aluminum under the anodization (F_u), and surface ablation (F_s). For an aspect of the instant invention 532 nm laser pulses yield the values are $F_b = 0.1 \text{ J/cm}^2$, $F_u = 0.13 \text{ J/cm}^2$, and $F_s = 0.18 \text{ J/cm}^2$. Fig 10 shows the fluence thresholds in Joules/cm² for 1064 nm (IR) laser pulses with parameters within those given in Tables 2 and 4. For an aspect of the instant invention the fluence threshold values for 1064 nm laser pulses in Joules/cm² are $F_u = 0.2 \text{ J/cm}^2$ and $F_s = 1.0 \text{ J/cm}^2$. Note that no threshold for bleaching anodization is available since IR wavelength laser pulses do not begin to bleach anodization until laser fluence is great enough to cause damage to the overlaying anodization. Note that the exact values for F_b , F_u and F_s will depend upon the particular laser and optics used. They must be determined experimentally for a given processing setup and article to be marked and stored in the controller for later use.

[0031] In another embodiment of this invention, the programmable nature of the adapted laser processing system permits the marking of anodized aluminum articles with commercially desirable marks in patterns. As shown in Fig 11, in this aspect a pattern 110 is converted into a digital representation 112, which is decomposed into a list 114, where each entry 116 in the list 114 contains a representation of a location or locations, with a color and optical density associated with each location. The list 114 is stored in the controller 20. The controller 20 associates laser parameters with each entry 116 in the list 114, which laser parameters, when sent as commands to the laser 10, optics 14 and motion control stage 22 will cause the laser 10 to generate one or more laser pulses 12 which impinge aluminum article 18 at or near the surface 16. These pulses will create a mark with the desired color and optical density. By moving the laser pulses 12 in relation to the aluminum article 18 according to the locations stored in the list as the marks are being created, marks of the desired range of colors and optical density are made on the anodized aluminum surface in the desired pattern.

[0032] In another embodiment of this invention colored anodization is patterned over previously patterned marks to present additional colors and optical densities. In this aspect, a grayscale pattern is created on an anodized aluminum article. The

article is then coated with a photoresist coating that can be developed by exposure to laser pulses. The grayscale patterned, photoresist coated article is placed into the laser processing system and aligned so that the system can apply laser pulses in registration with the pattern already applied to the article. The photoresist used is a type known as "negative" photoresist, where areas exposed to laser radiation will be removed and the unexposed areas will remain on the article following subsequent processing. The remaining photoresist protects the surface of the article from introduction of dyes, while the areas of the anodization which had been exposed and subsequently removed will be dyed the desired color. This anodization layer is designed to be translucent in order to allow light to pass through the anodization to the pattern below and be reflected back through the anodization and thereby create color patterns with selected color and optical density. This color anodization can also be bleached if necessary using techniques disclosed by other aspects of this invention to create a desired color with desired transparency. This color can be applied over areas of the underlying pattern or applied on a point-by-point basis down to the limits of resolution of the laser system, typically in the 10 to 400 micron range. This operation can be repeated to create multiple color overlays. In one aspect of this invention, the anodization color overlay is applied in a multiple color overlay grid, such as Bayer pattern. By designing the grayscale pattern to work with the color overlay grid, a durable, commercially desirable full color image can be created on the anodized aluminum article.

[0033] Figs 12a through 12i show a sequence of steps used to create this color overlay for two colors. In Fig 12a, an aluminum article 118 has a transparent anodization layer 120 and marks 122 previously applied according to other aspects of this invention. A negative photoresist 124 is applied to the surface of the transparent anodization 120. In Fig 12b, laser pulses 126 expose areas 128, 130 of the photoresist 124. In Fig 12c the unexposed resist 134 remains following resist processing, but the exposed resist has been removed leaving voids 132 in the processed resist layer 134. Fig 12d shows the base anodization layer 120 with sections 136 where the anodization has been dyed with color beneath the voids 132 in the processed resist layer 134. The intact processed resist 134 prevents the anodization from acquiring color anywhere except where the processed resist 134 has been removed 132. Fig 12e shows the article 118 with base anodization 120

with color portions of anodization 136 in relation to previously applied marks 122 following removal of processed resist.

[0034] Fig 12f shows an article 118 with base anodization 120 including colored portions 136 and a second resist layer 138. Fig 12g shows this second layer of resist 138 impinged by laser pulses 142 to cause area 140 to become exposed. Fig 12h shows the article 118 with base anodization 120 following processing to, dye the anodization beneath the removed resist 140, and removal of the remaining resist 138. This leaves the intact base anodization layer with colored areas 136, 144 over the previously marked areas 122. Fig 12i shows subsequent laser pulses 146 being used to optionally bleach portions of the previously anodized and dyed portions of the aluminum article to create additional desired colors or optical densities. The processing described by this aspect of this invention results in a colored pattern being overlaid over a grayscale pattern, yielding marks with a wide range of durable, commercially desirable colors and optical densities in patterns which are programmable.

[0035] In another embodiment of this invention, the color anodization may be created on the anodized aluminum article in particular patterns which yield the appearance of full color images when viewed. In this aspect, a pattern representative of an image is applied to the surface using techniques described herein. The color dyes are introduced in the manner illustrated in Figs 12a through 12i, except that the pattern with which these dyes are introduced into the base layer of anodization is designed to convert the grayscale representation into full color. An example of such a pattern is a Bayer filter (not shown), which juxtaposes red, green and blue filter elements in a pattern such that the eye perceives the red, green and blue elements fusing into a single color with optical density related to the grayscale mark underneath the color anodization filters, thereby creating the appearance of a full color image or pattern. The resist may be negative or positive resist, and the patterns which expose the resist may be created by masks, such as used in circuit or semiconductor applications, or directly written by an electronic means or directly deposited by technologies such as inkjet or directly ablated by laser.

[0036] In another embodiment of this invention, the adapted laser marking system 148 is shown in Fig 13 to include a nozzle 164 and fluid supply 166. Fig 13 shows an adapted laser marking system 148 including a laser 150 which emits laser pulses which travel along a laser beam path 152, which travels through beam steering

optics 154 where it is directed to impinge an article 158 which is fixtured on a motion stage 162, all under control of a controller 160. The nozzle 164 is supplied with fluid by fluid supply 166 and directs a fluid flow 168 to the article 158 at or near the location being impinged by the laser beam 152 at or near the time the laser 150 is energized and emitting pulses along the laser beam 152. In some embodiments, the nozzle 164 is attached to motion control equipment 170 which, under direction of the controller 160, moves the nozzle 164 and hence the fluid flow 168 in relation to the article 158 thereby directing the fluid flow 168 to the vicinity of the location on the article 158 where the laser beam 152 impinges the article. In other embodiments the surface of the article 158 can be flooded with fluid while laser machining, eliminating the need to move the nozzle 164 in conjunction with the laser beam 152.

[0037] This fluid flow 168 cools the surface of the article and increases the amount of fluence that can be applied to a location on the article 158. This increases F_s for the particular anodized aluminum article being marked therefore allowing more fluence to be used to alter the surface of the aluminum at the interface between aluminum and oxide, but also permits greater fluence and therefore greater throughput. In this embodiment water is used as the fluid however, air or other gasses such as nitrogen or argon or other fluids could be used. The purpose of the fluid flow on the surface is to keep the temperature of the anodization from reaching the temperature at which significant damage starts. Fluid flow rates which reduce temperatures adequately for given laser parameters are determined empirically and will differ depending upon the fluid used and the heat transfer-related properties of the anodization and metal article.

[0038] The ways in which fluid is delivered to the surface of the article while the laser marking is occurring depends upon the fluid used. Where the fluid flow is a small stream of relatively high velocity fluid, such as air or inert gas, the nozzle 164 may have to be mechanically coupled to the beam steering optics 154 to maintain the alignment of the fluid flow 168 and the laser beam path 152. In the case of a fluid such as water, the surface of the article may be flooded, thereby providing thermal protection over a large area without requiring that the nozzle 164 be made to move while the article 158 is being laser marked.

[0039] This cooling effect allows the laser parameters used to create marks to change to permit more intense color marking, greater anodization bleaching and increased throughput while limiting damage to the anodization caused by thermal

stress. Fig 14a shows an anodized article 180 with dyed anodization 182. A portion of the anodization has been laser bleached 184, which has resulted in cracking of the anodization 186. Laser parameters used are listed in Table 5.

| | |
|----------------|--------------------------|
| Laser Type | DPSS Nd:YOV ₄ |
| Wavelength | 532 nm |
| Pulse duration | 10 ps |
| Pulse temporal | Gaussian |
| Laser power | 2W |
| Rep Rate | 200 KHz |
| Speed | 100 mm/s |
| Pitch | 10 microns |
| Spot size | 10-400 microns |
| Spot shape | Gaussian |
| Focal Height | 0-5 mm |

Table 5. Laser bleaching parameters

[0040] In Fig 14a, the dyed anodization is bleached using laser parameters listed in Table 5. In this embodiment laser parameters are selected which result in high power, stable operation of the laser and a marking rate which provides good system throughput. The focal height is then adjusted to provide fine control over the laser fluence. In this case a laser fluence of 0.38 J/cm² is used to bleach the anodization, which also creates cracks 186, which are undesirable. For this particular sample, all fluences above 0.13 J/cm² results in cracking of the anodization. Thus, for this particular sample, the anodization cannot be efficiently bleached without cracking the anodization. Fig 14b shows the results of employing an embodiment of this invention to bleach anodization also using laser parameters listed in Table 5. An anodized article 190 has been dyed 192 and a portion 194 has been bleached in the presence of a fluid. Note that no cracks are visible in this sample in spite of being bleached using laser fluence of 0.25 J/cm². Cracking was prevented by flooding the article with 2-3 mm of water during laser beaching.

[0041] Laser parameters which may be advantageously employed by embodiments of this invention include using lasers with wavelengths which range from IR through UV, or more particularly from about 10.6 microns down to about 355 nm. The laser operates at 2 W, being in the range of 1 W to 100 W, or more preferably 1 W to 12 W. Pulse durations range from 1 ps to 1000 ns, or more preferably from 1 ps to 200 ns. The laser rep rate is in the range from 1 K Hz to 100 M Hz, or more preferably from 10 KHz to 1 MHz. Laser fluence ranges from about $0.1 \times 10^{-6} \text{ J/cm}^2$ to 100.0 J/cm^2 or more particularly from $1.0 \times 10^{-2} \text{ J/cm}^2$ to 10.0 J/cm^2 . The speed with which the laser beam moves with respect to the article being marked ranges from 1 mm/s to 10 m/s, or more preferably from 100 mm/s to 1 m/s. The pitch or spacing between adjacent rows of laser pulses on the surface of the article ranges from 1 micron to 1000 microns or more preferably from 10 microns to 100 microns. The spot size of the laser pulses measured at the surface of the article ranges from 10 microns to 1000 microns or more preferably from 50 microns to 500 microns. The location of the focal spot of the laser pulses with respect to the surface of the article ranges from -10 mm to +10 mm or more particularly from 0 to +5 mm.

[0042] It will be apparent to those of ordinary skill in the art that many changes may be made to the details of the above-described embodiments of this invention without departing from the underlying principles thereof. The scope of the present invention should, therefore, be determined only by the following claims.

We claim:

1. A method for creating a mark with desired properties on an anodized article comprising:

providing a laser marking system having programmable laser pulse parameters and a fluid upon said anodized article;

determining the particular laser pulse parameters associated with creating said mark with said desired properties in the presence of said fluid;
and

directing said laser marking system to mark said anodized article using said determined particular laser pulse parameters while said fluid is upon said anodized aluminum article thereby creating said mark with said desired properties.

2. The method of claim 1 wherein said anodized article is anodized aluminum.

3. The method of claim 1 wherein said desired properties comprise size, shape, location, color and optical density.

4. The method of claim 1 wherein said laser pulse parameters comprise pulse width, wavelength, number of pulses, pulse temporal shape, pulse fluence, spot size, spot shape, and focal spot.

5. The method of claim 1 wherein said fluid is water.

6. The method of claim 1 wherein said fluid is provided as a flow.

7. The method of claim 6 wherein said fluid flow is moved in relation to said article to maintain a relationship between said fluid and said laser pulses.

8. The method of claim 1 wherein said marks are created by dyeing and optionally bleaching said anodized article.
9. The method of claim 4 wherein said pulse width ranges from about 1 picosecond to about 1000 nanoseconds.
10. The method of claim 4 wherein said wavelength ranges about 10.6 microns down to about 355 nanometers.
11. The method of claim 4 wherein said number of pulses ranges from 1 to about 10000 pulses.
12. The method of claim 4 wherein said pulse temporal shape is Gaussian.
13. The method of claim 4 wherein said pulse temporal shape is tailored.
14. The method of claim 4 wherein said pulse fluence ranges from 1.0×10^{-6} Joules/cm² to 10.0 Joules/cm².
15. The method of claim 4 wherein said spot size ranges from about 10 microns to about 1000 microns.
16. The method of claim 4 wherein said spot shape is one of Gaussian or shaped.
17. The method of claim 4 wherein said focal spot is focused at one of on the surface, above the surface, or below the surface of said anodized aluminum specimen.
18. The method of claim 3 wherein said desired optical density is equal to or less than about $L^*=40$, $a^*=5$, and $b^*=10$.
19. The method of claim 3 wherein said desired color is one of white, black, transparent, gray, tan, or gold.

20. A laser marking apparatus adapted to produce marks with desired properties on an anodized article comprising:

a laser operative to produce laser pulses;

laser optics operative to modify and direct said laser pulses;

a stage operative to hold and position said anodized aluminum specimen;

a fluid operative to absorb heat from said anodized specimen; and

a controller operative to access predetermined laser pulse parameters and in cooperation with said laser, laser optics and stage, create and direct said laser pulses according to said predetermined laser pulse parameters to impinge upon said anodized article while said fluid absorbs heat created by said laser pulses from said anodized specimen thereby producing said marks with said desired properties.

21. The apparatus of claim 20 wherein said anodized article is anodized aluminum.

22. The apparatus of claim 20 wherein said desired properties comprise size, shape, location, color and optical density.

23. The apparatus of claim 20 wherein said laser pulse parameters comprise pulse width, wavelength, number of pulses, pulse temporal shape, pulse fluence, spot size, spot shape, and focal spot.

24. The apparatus of claim 20 wherein said fluid is water.

25. The apparatus of claim 20 wherein said fluid is provided as a flow.

26. The method of claim 25 wherein said fluid flow is moved in relation to said article to maintain a relationship between said fluid and said laser pulses.
27. The apparatus of claim 20 wherein said marks are created by dyeing and optionally bleaching said anodized aluminum article.
28. The apparatus of claim 23 wherein said pulse width ranges from about 1 picosecond to about 1000 nanoseconds.
29. The apparatus of claim 23 wherein said wavelength ranges about 10.6 microns down to about 355 nanometers.
30. The apparatus of claim 23 wherein said number of pulses ranges from 1 to about 10000 pulses.
31. The apparatus of claim 23 wherein said pulse temporal shape is Gaussian.
32. The apparatus of claim 23 wherein said pulse temporal shape is tailored.
33. The apparatus of claim 23 wherein said pulse fluence ranges from 1.0×10^{-6} Joules/cm² to 10.0 Joules/cm².
34. The apparatus of claim 23 wherein said spot size ranges from about 10 microns to about 1000 microns.
35. The apparatus of claim 23 wherein said spot shape is one of Gaussian or shaped.
36. The apparatus of claim 23 wherein said focal spot is focused at one of on the surface, above the surface, or below the surface of said anodized aluminum specimen.
37. The apparatus of claim 22 wherein said desired optical density is equal to or less than about $L^*=40$, $a^*=5$, and $b^*=10$.

38. The apparatus of claim 22 wherein said desired color is one of white, black, transparent, gray, tan, or gold.

39. The apparatus of claim 20 wherein said marks are created by dying and optionally bleaching said anodized aluminum article.

40. The apparatus of claim 20 wherein said laser parameters are selected to produce said marks on said anodized aluminum article in a desired pattern with varying optical densities so as to form an image.

41. The apparatus of claim 20 wherein colored anodization is applied over said image by selectively removing a photoresist layer to expose said anodization and dying and optionally bleaching said exposed, dyed anodization, thereby producing a color image.

1/17

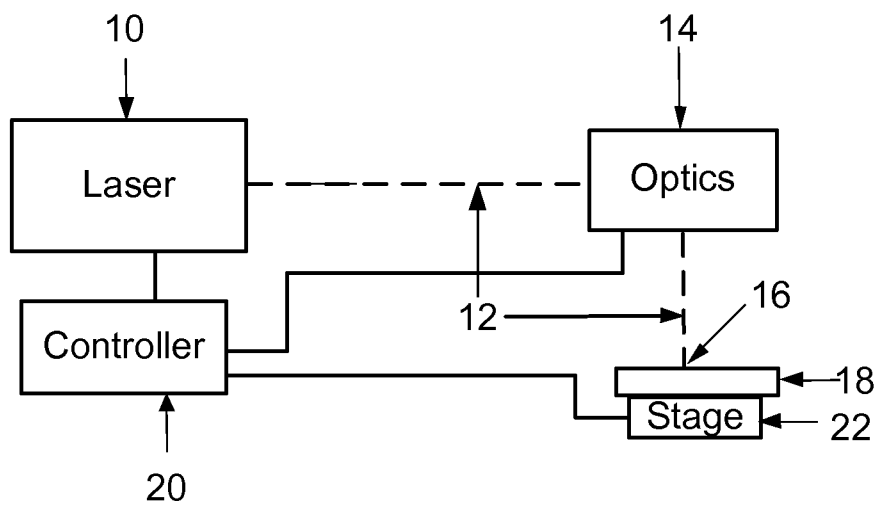

Fig. 1

2/17

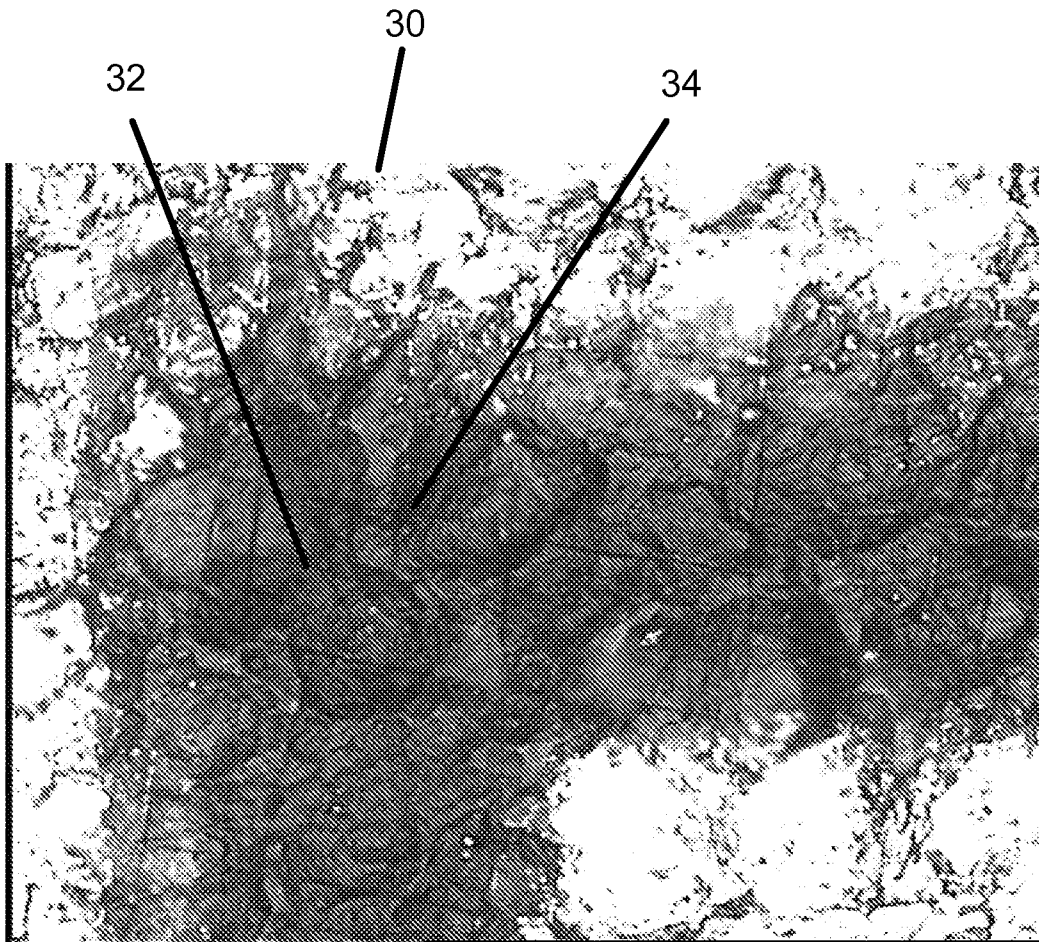

Fig 2
Prior Art

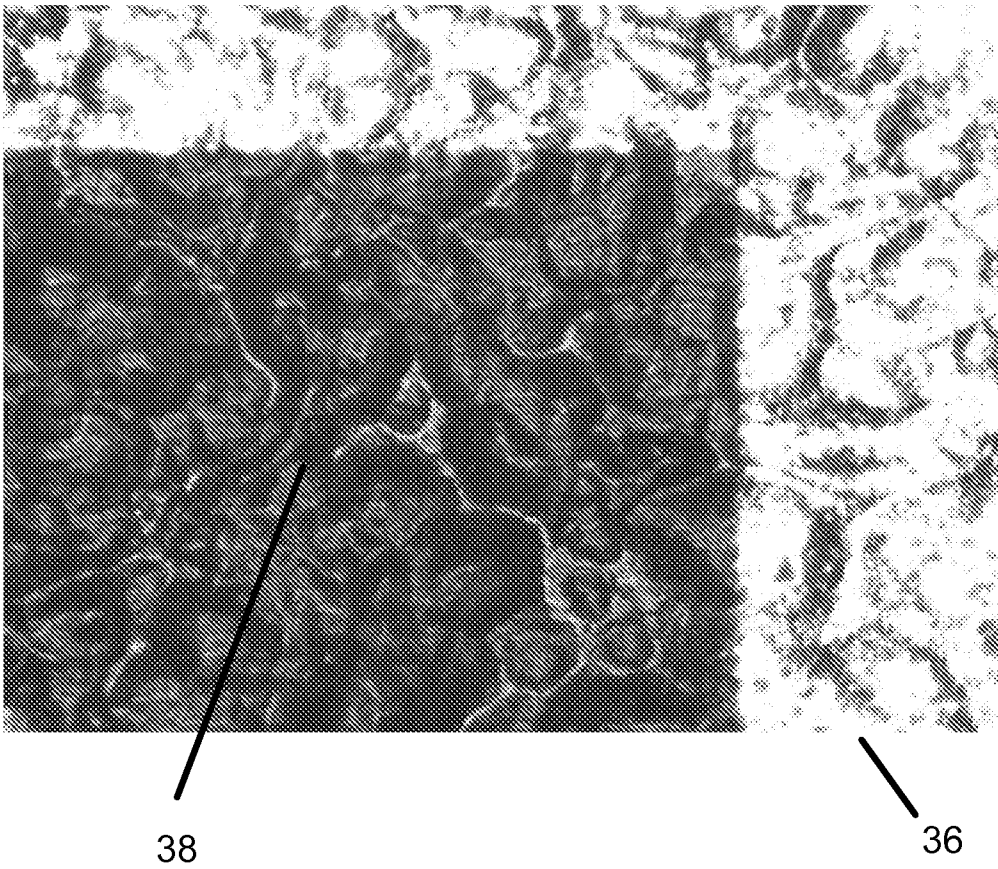

Fig 3

4/17

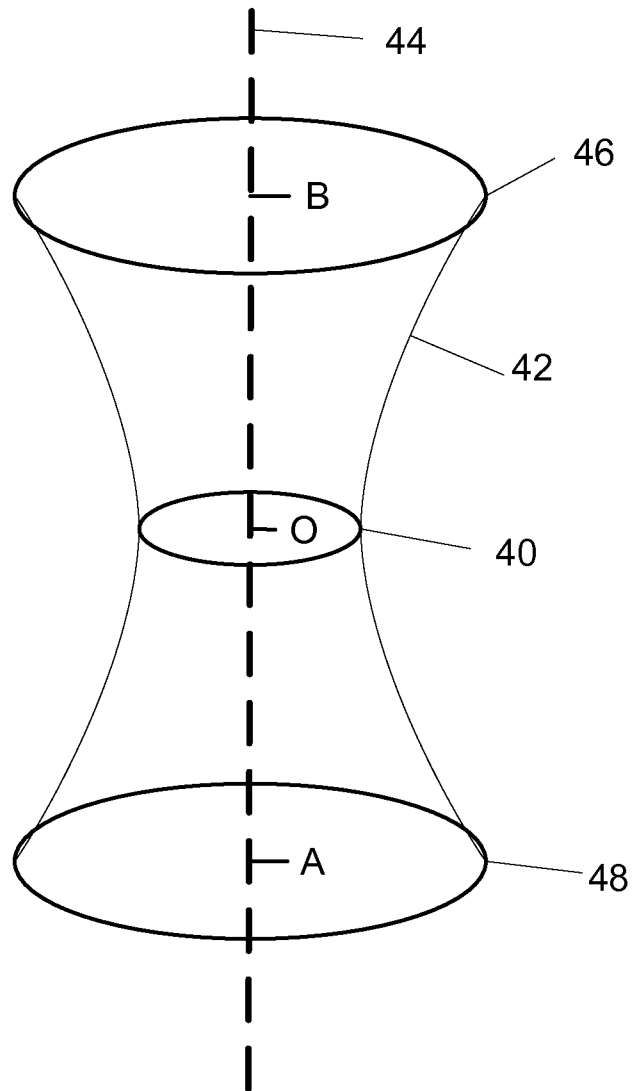

Fig 4

5/17

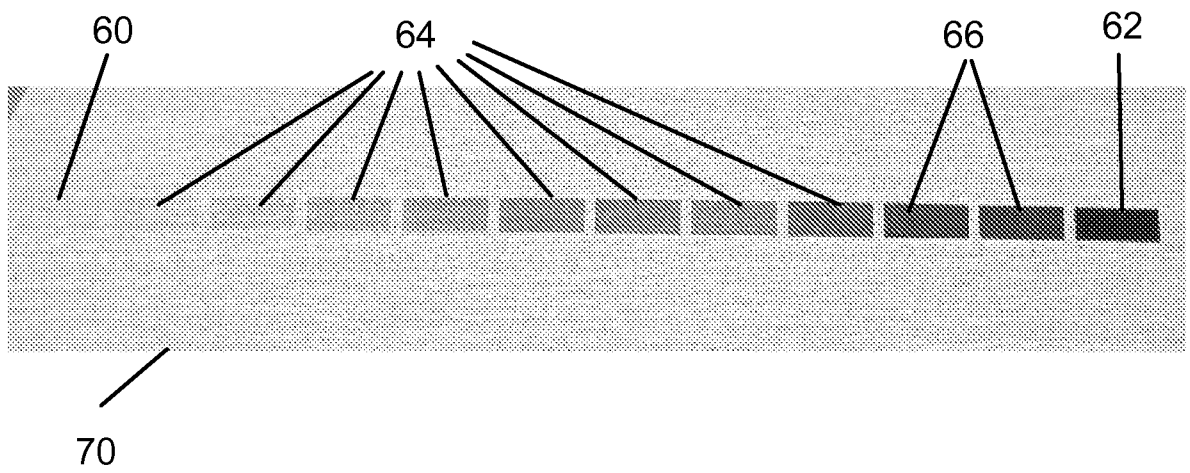

Fig 5

6/17

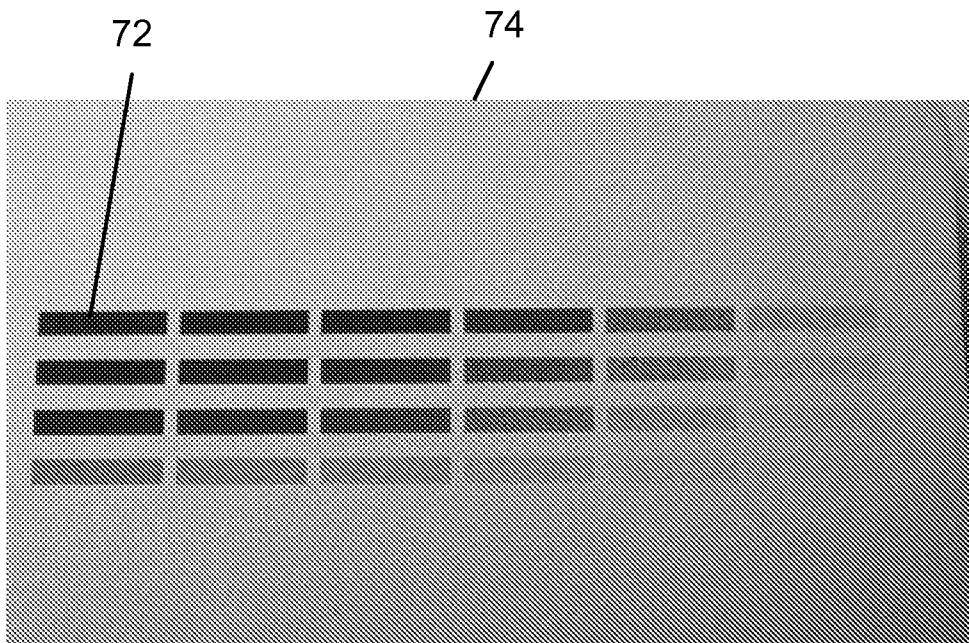

Fig 6

7/17

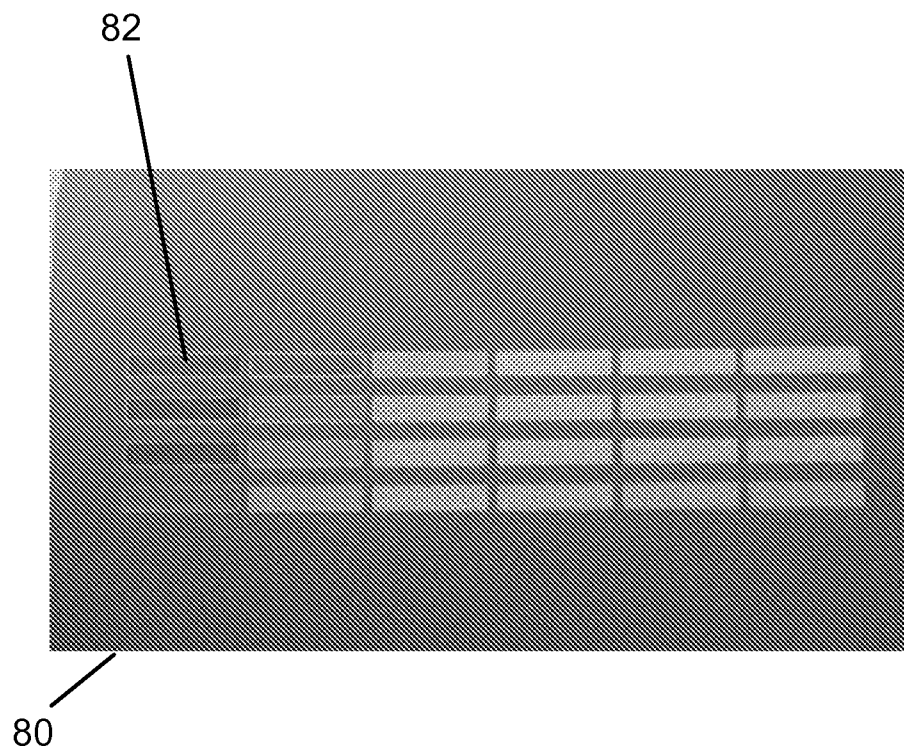

Fig 7

8/17

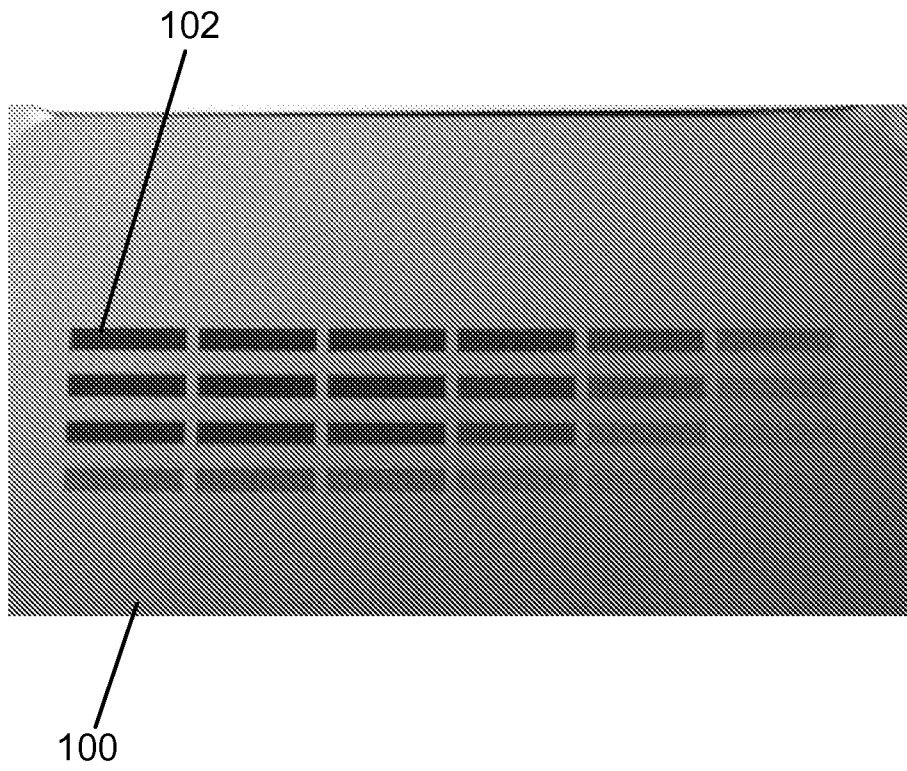
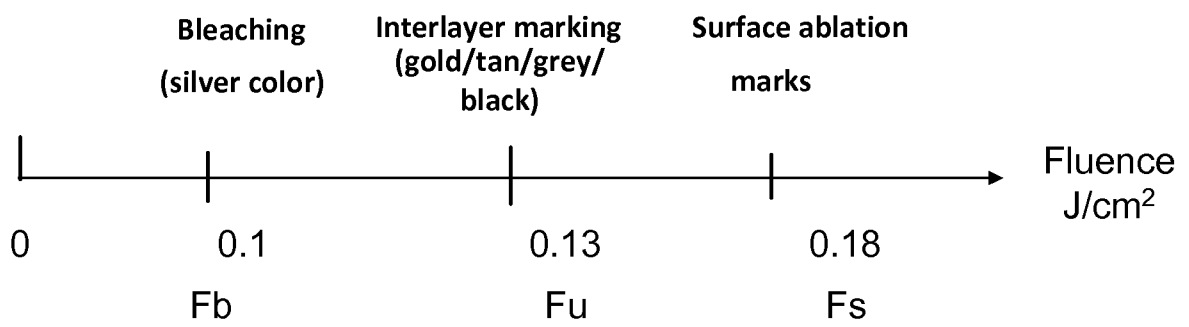

Fig 8

9/17



Fluence Thresholds for 532 nm Wavelength

Fig 9

10/17

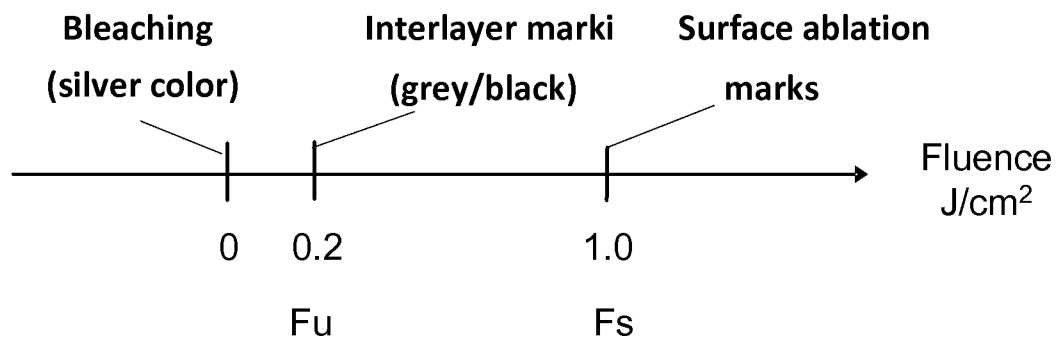

Fluence Thresholds for 1064 nm Wavelength

Fig 10

11/17

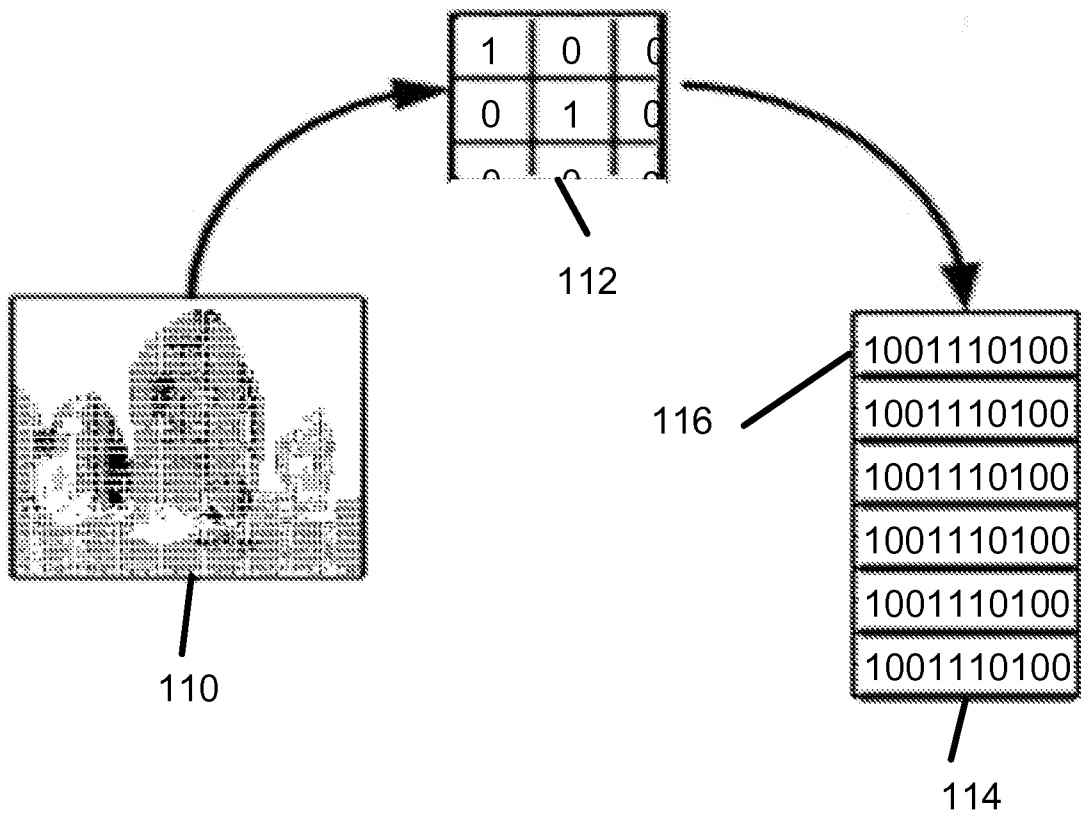

Fig 11

12/17

Fig 12a

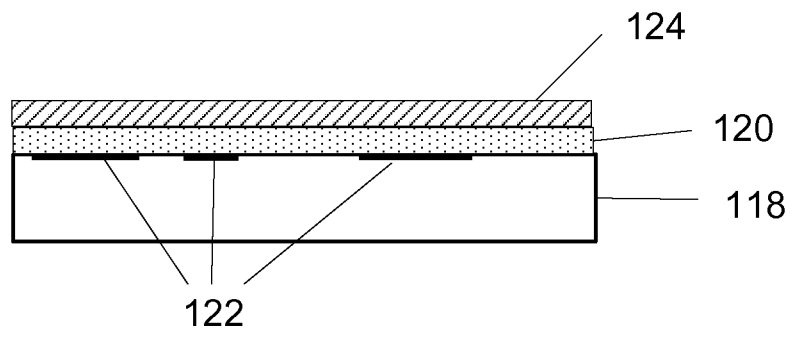

Fig 12b

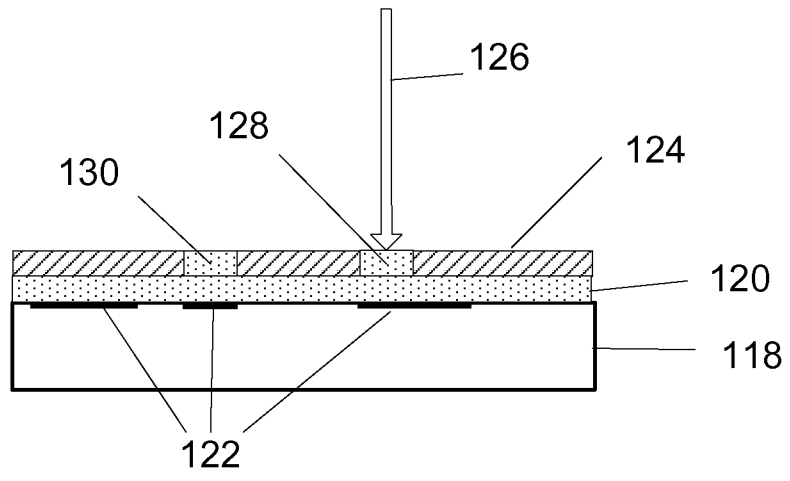
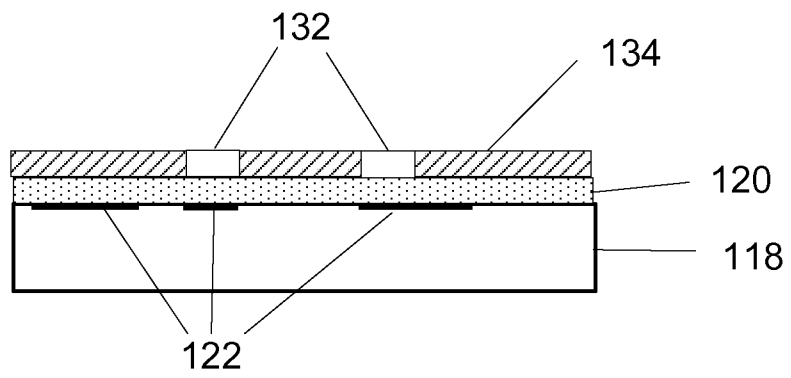
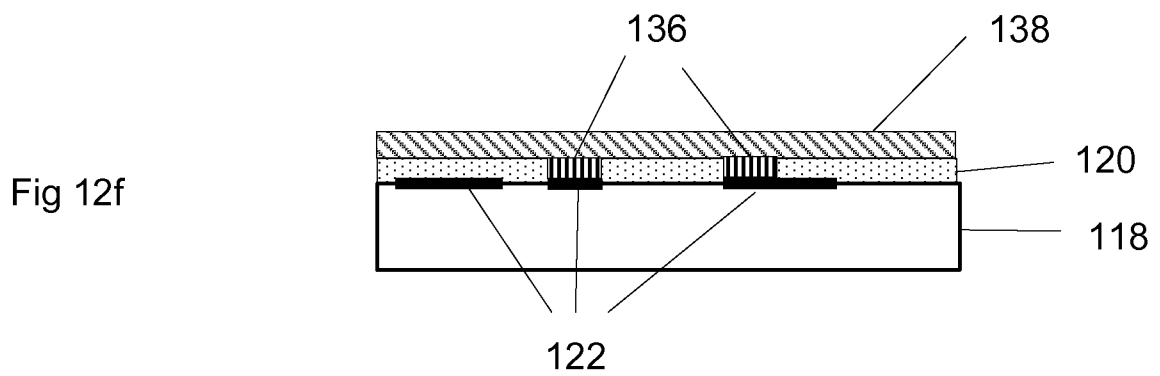
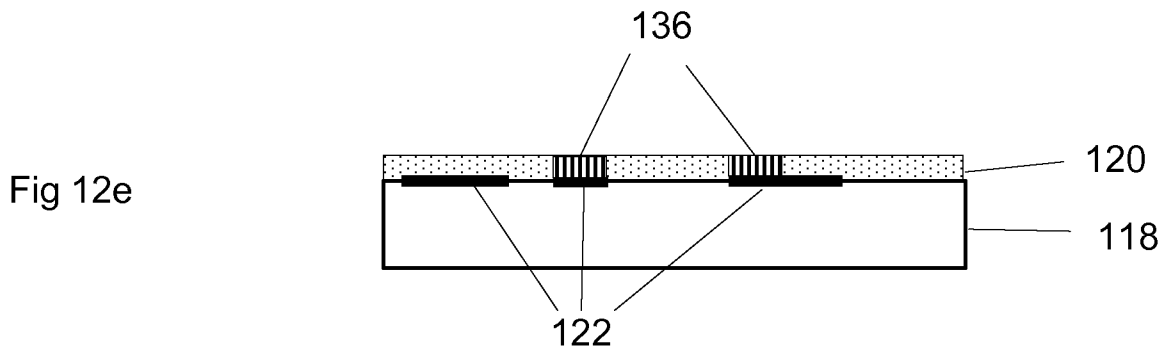
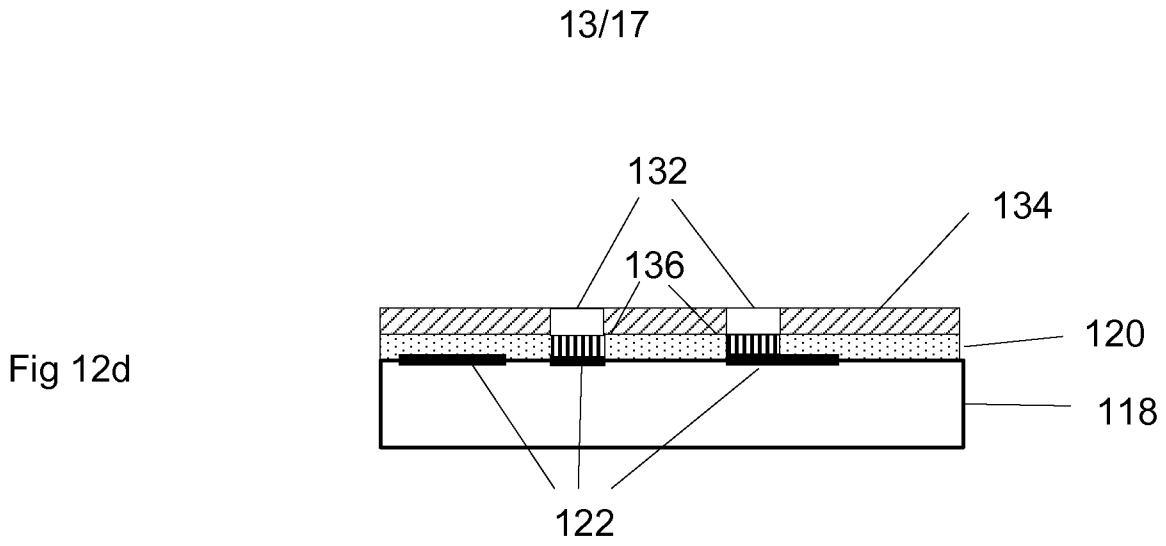
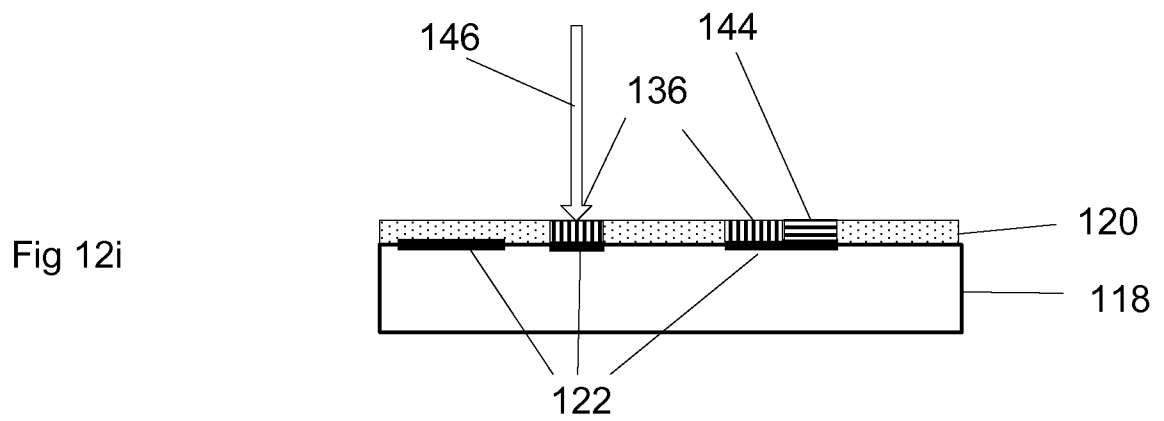
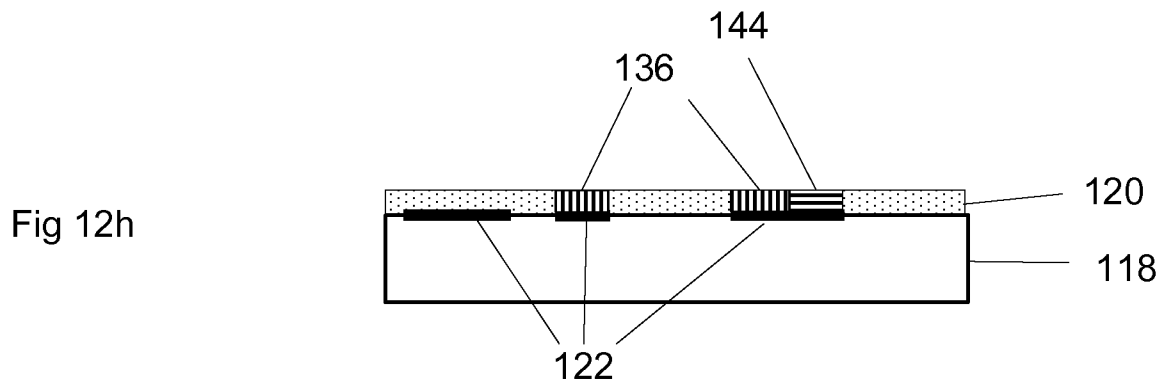
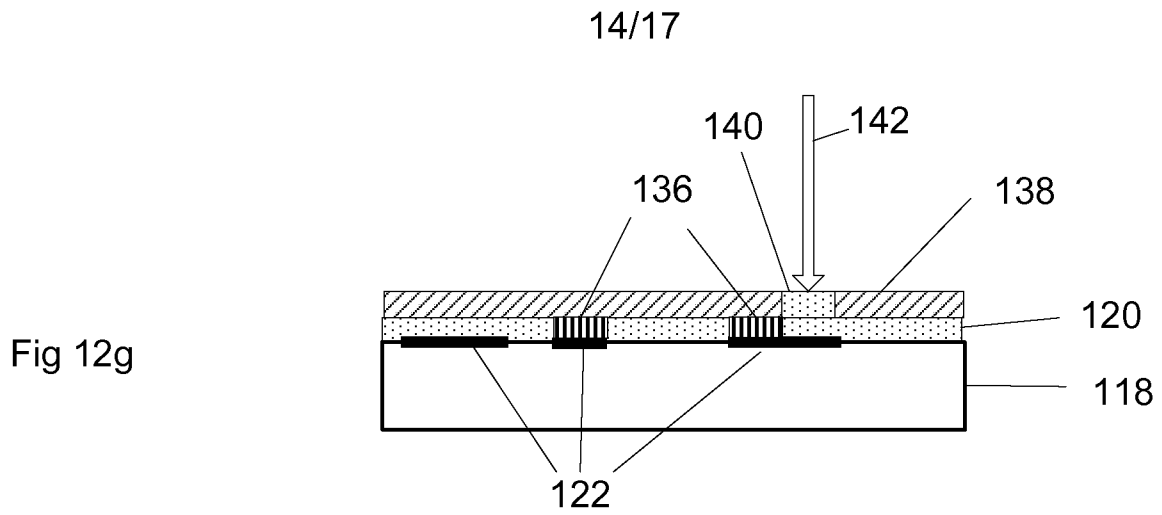

Fig 12c







15/17

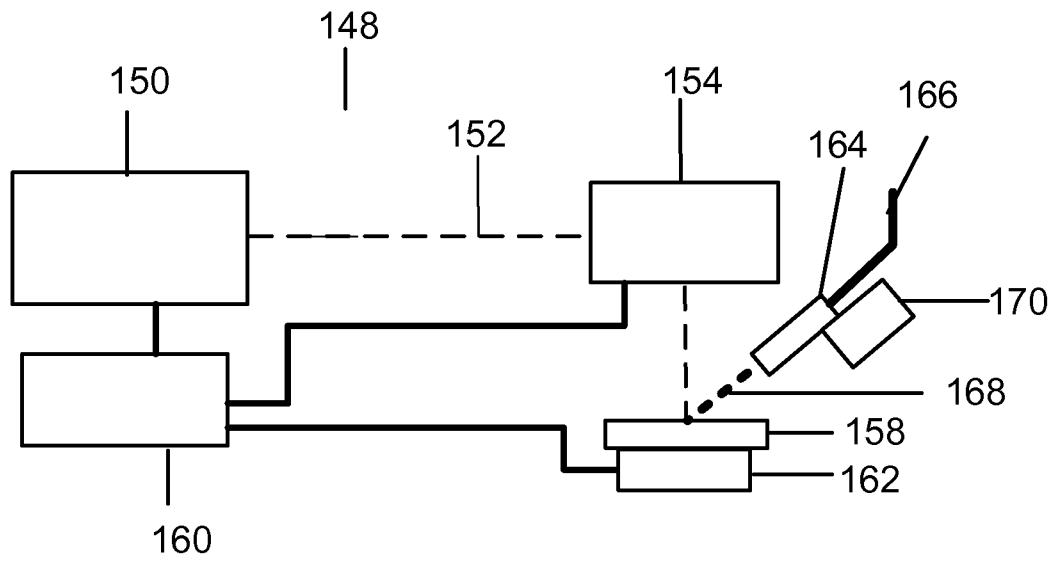

Fig. 13

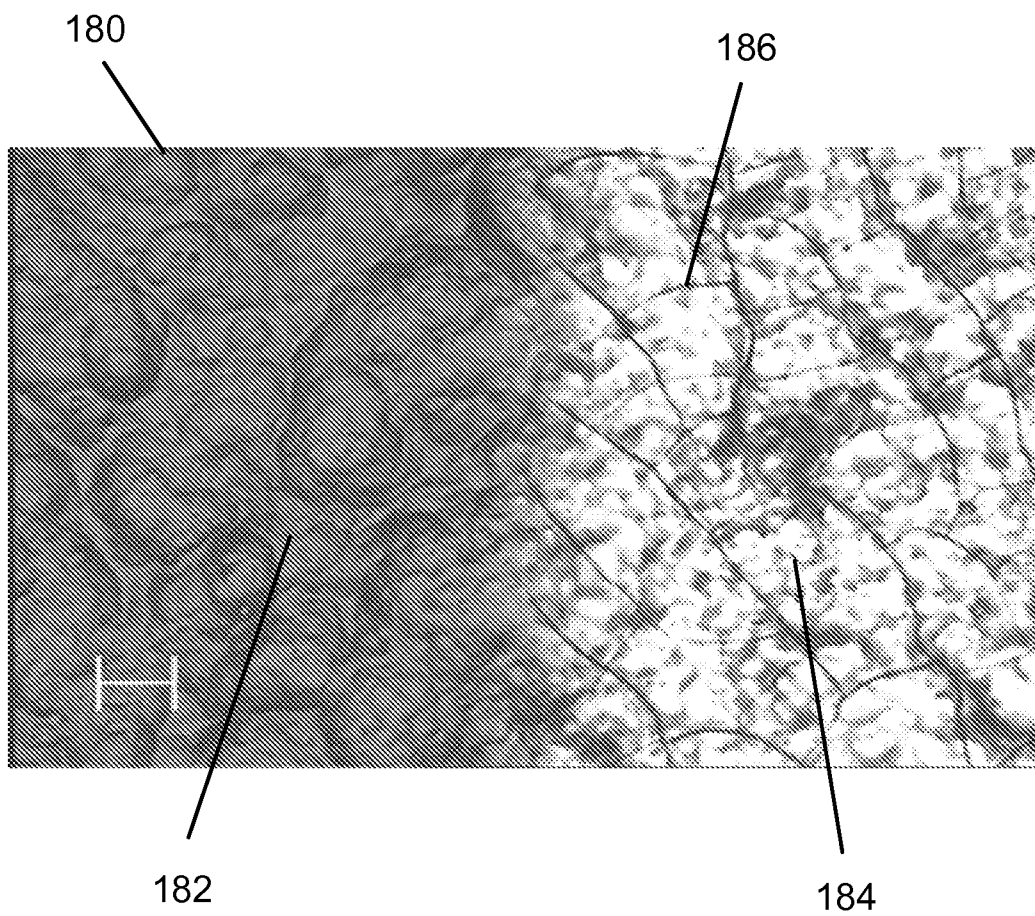

Fig 14a

17/17

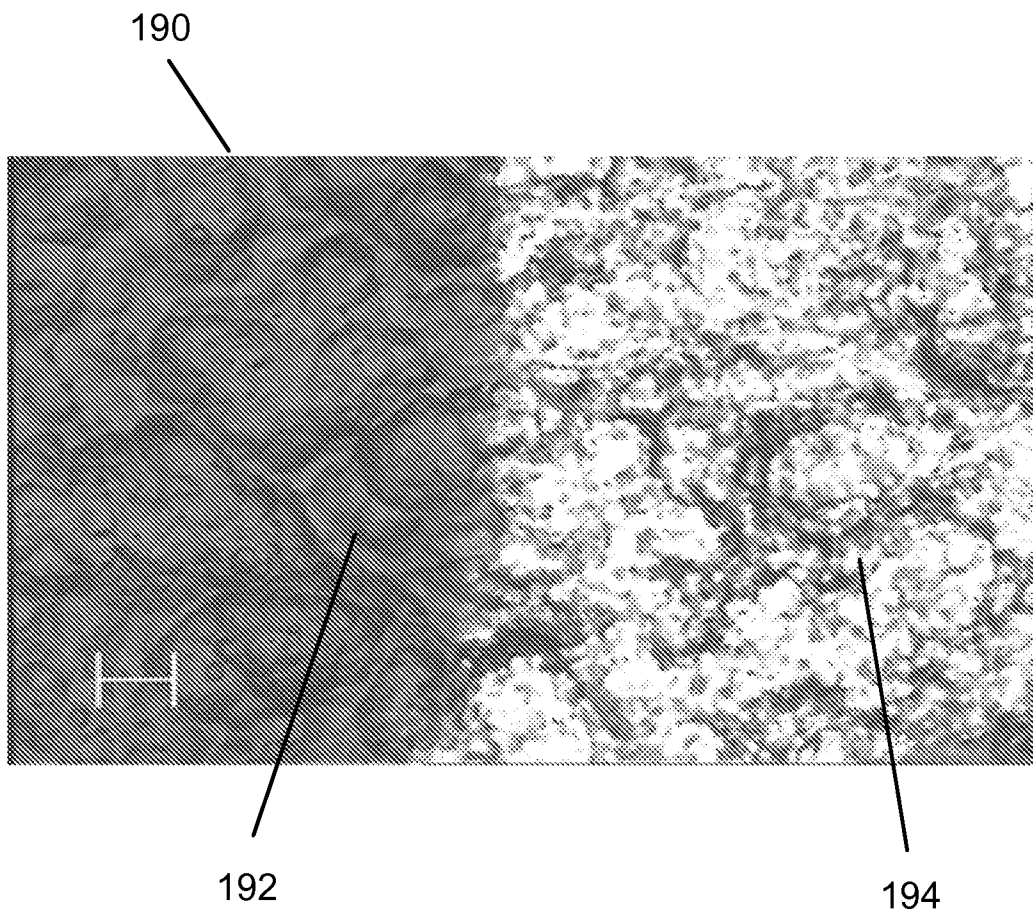



Fig 14b

INTERNATIONAL SEARCH REPORT

International application No.
PCT/US2011/027946

| A. CLASSIFICATION OF SUBJECT MATTER | | |
|--|--|--|
| <i>B23K 26/18(2006.01)i, B23K 26/36(2006.01)i, B23K 26/04(2006.01)i, H01S 3/10(2006.01)i, B23K 103/10(2006.01)n</i> | | |
| According to International Patent Classification (IPC) or to both national classification and IPC | | |
| B. FIELDS SEARCHED | | |
| Minimum documentation searched (classification system followed by classification symbols) B23K 26/18; B41M 5/24; B23K 26/38; B23K 26/00 | | |
| Documentation searched other than minimum documentation to the extent that such documents are included in the fields searched Korean utility models and applications for utility models Japanese utility models and applications for utility models | | |
| Electronic data base consulted during the international search (name of data base and, where practicable, search terms used) eKOMPASS(KIPO internal) & Keywords: laser, anodize, aluminum, mark, fluid | | |
| C. DOCUMENTS CONSIDERED TO BE RELEVANT | | |
| Category* | Citation of document, with indication, where appropriate, of the relevant passages | Relevant to claim No. |
| A | US 6590183 B1 (YEO; KENG KIT) 08 July 2003 See Abstract; Claim 1 and Figures 1-3 | 1-41 |
| A | JP 07-204871 A (FUJI ELECTRIC CO. LTD.) 08 August 1995 See Abstract and Figure 1 | 1-41 |
| A | US 04547649A A (BUTT; DONALD B. et al.) 15 October 1985 See Abstract and Figure 2 | 1-41 |
| <input type="checkbox"/> Further documents are listed in the continuation of Box C. <input checked="" type="checkbox"/> See patent family annex. | | |
| * Special categories of cited documents: "A" document defining the general state of the art which is not considered to be of particular relevance "E" earlier application or patent but published on or after the international filing date "L" document which may throw doubts on priority claim(s) or which is cited to establish the publication date of citation or other special reason (as specified) "O" document referring to an oral disclosure, use, exhibition or other means "P" document published prior to the international filing date but later than the priority date claimed "T" later document published after the international filing date or priority date and not in conflict with the application but cited to understand the principle or theory underlying the invention "X" document of particular relevance; the claimed invention cannot be considered novel or cannot be considered to involve an inventive step when the document is taken alone "Y" document of particular relevance; the claimed invention cannot be considered to involve an inventive step when the document is combined with one or more other such documents, such combination being obvious to a person skilled in the art "&" document member of the same patent family | | |
| Date of the actual completion of the international search 20 DECEMBER 2011 (20.12.2011) | | Date of mailing of the international search report 20 DECEMBER 2011 (20.12.2011) |
| Name and mailing address of the ISA/KR  Korean Intellectual Property Office Government Complex-Daejeon, 189 Cheongsu-ro, Seo-gu, Daejeon 302-701, Republic of Korea Facsimile No. 82-42-472-7140 | | Authorized officer Hong, Sung Ui Telephone No. 82-42-481-5524  |

INTERNATIONAL SEARCH REPORT

Information on patent family members

International application No.

PCT/US2011/027946

| Patent document cited in search report | Publication date | Patent family member(s) | Publication date |
|--|------------------|-------------------------|------------------|
| US 6590183 B1 | 08.07.2003 | CN 1173839 C0 | 03.11.2004 |
| | | CN 1336878 A0 | 20.02.2002 |
| | | DE 60036078 D1 | 04.10.2007 |
| | | DE 60036078 T2 | 15.05.2008 |
| | | EP 1147020 A1 | 24.10.2001 |
| | | EP 1147020 B1 | 22.08.2007 |
| | | JP 04-762471 B2 | 17.06.2011 |
| | | JP 2003-513828 A | 15.04.2003 |
| | | JP 2003-513828 T | 15.04.2003 |
| | | US 2003-0201259 A1 | 30.10.2003 |
| | | US 6777098 B2 | 17.08.2004 |
| | | WO 01-34408 A1 | 17.05.2001 |
| | | JP 07-204871 A | 08.08.1995 |
| US 04547649A A | 15.10.1985 | None | |