

J. R. FIALA.

PROPELLER.

APPLICATION FILED OCT. 3, 1910.

999,768.

Patented Aug. 8, 1911.

2 SHEETS—SHEET 1.

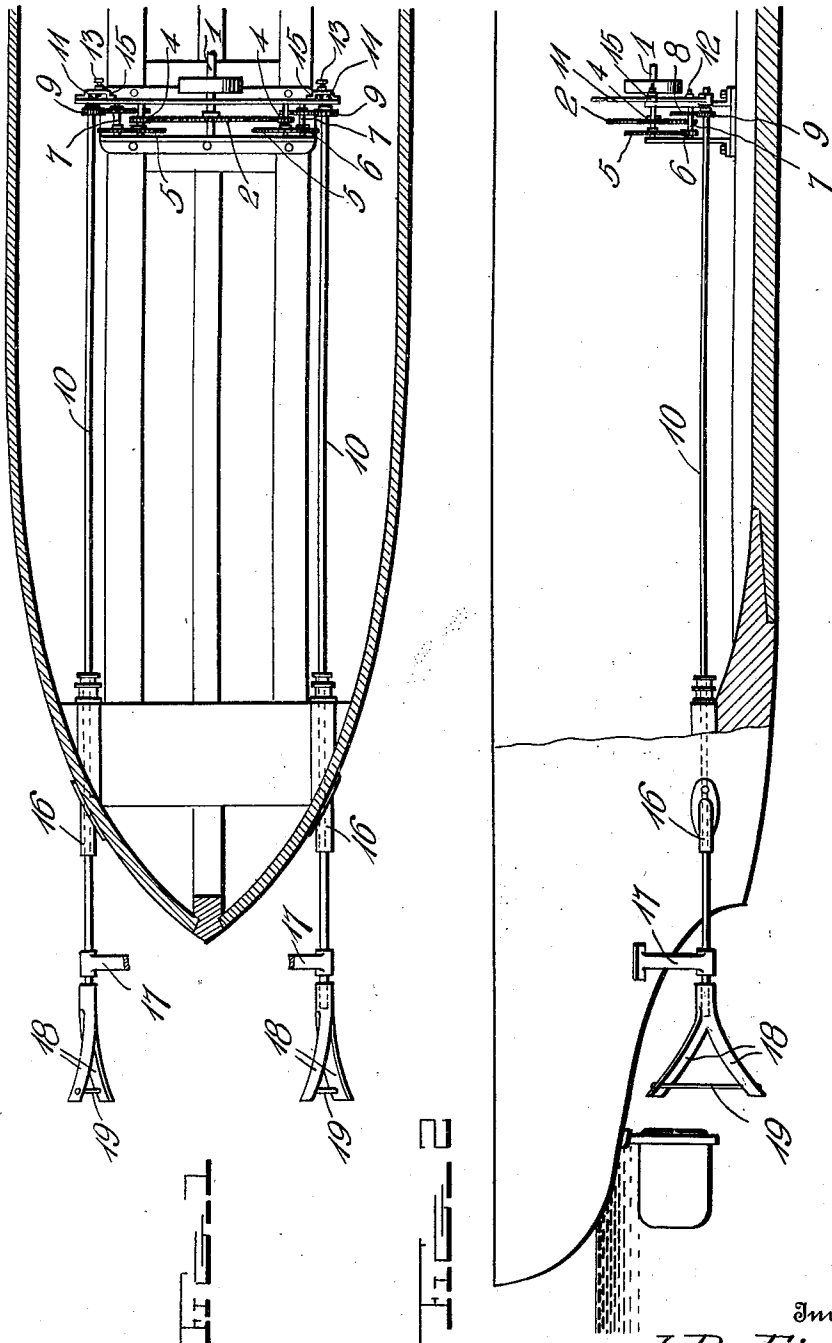

Witnesses

E. Allen

E. Diton

Inventor

J. R. Fiala

By

D. Swift & Co.

Attorneys

J. R. FIALA.  
PROPELLER.

APPLICATION FILED OCT. 3, 1910.

999,768.

Patented Aug. 8, 1911.

2 SHEETS—SHEET 2.

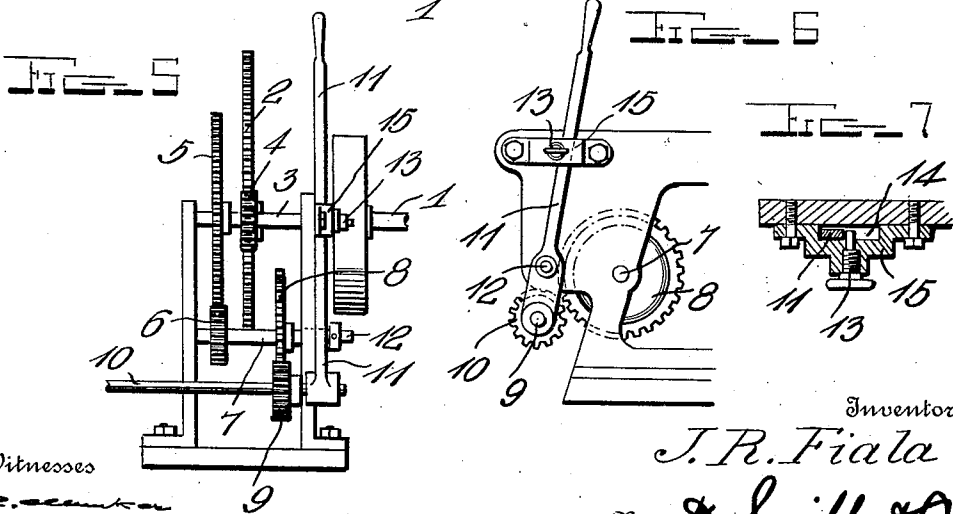
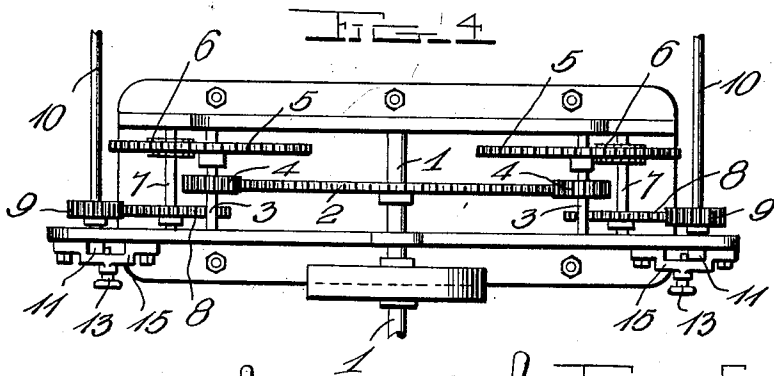
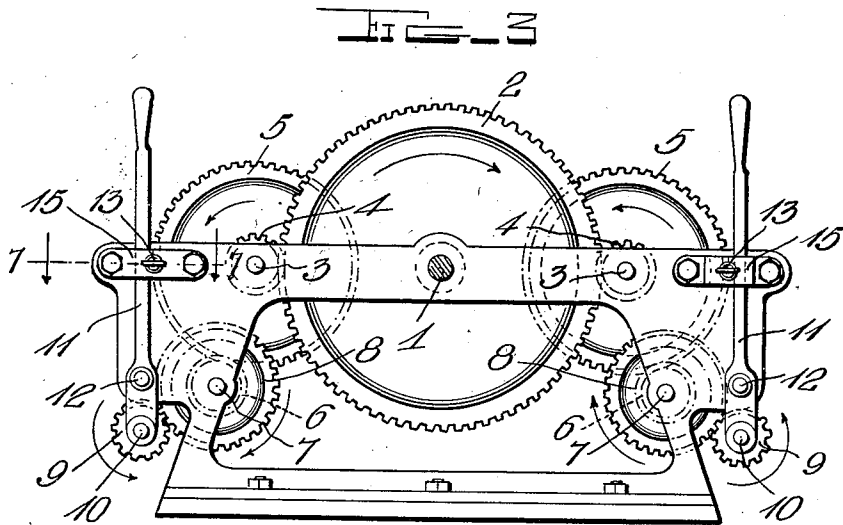

Witnesses

*E. Dixon*

Inventor

*J. R. Fiala*

By

*D. Swift & Co.*

Attorneys

# UNITED STATES PATENT OFFICE.

JOSEF R. FIALA, OF OMAHA, NEBRASKA.

## PROPELLER.

999,768.

Specification of Letters Patent.

Patented Aug. 8, 1911.

Application filed October 3, 1910. Serial No. 585,041.

*To all whom it may concern:*

Be it known that I, JOSEF R. FIALA, a citizen of the United States, residing at Omaha, in the county of Douglas and State of Nebraska, have invented a new and useful Propeller; and I do hereby declare the following to be a full, clear, and exact description of the invention, such as will enable others skilled in the art to which it appertains to make and use the same.

The invention relates to propellers and has for its object to provide a propeller especially designed where great speed is desired.

A further object of the invention is to provide propelling mechanism for twin propellers and so disposed that the propellers may be one or both disengaged from the operating mechanism.

A further object of the invention is to provide a propeller of that class having a link or rod connecting the extremities of the propeller, thereby relieving the same from part of the strain incident to rapid motion.

I desire it to be understood that changes in form, proportion and arrangement of parts may be freely resorted to without departing from the spirit of this invention or sacrificing any advantages thereof, provided that said changes fall within the scope hereinafter claimed.

In the drawings, Figure 1 is a horizontal sectional view through the hull of a vessel, showing my propeller and mechanism for operating the same applied thereto. Fig. 2 is a side elevation thereof partly in section. Fig. 3 is a front elevation of the twin screw operating mechanism. Fig. 4 is a plan view of the operating mechanism. Fig. 5 is an end view. Fig. 6 is a fragmentary elevation, showing one of the propellers out of operation. Fig. 7 is a detail horizontal sectional view taken on the line 7-7 of Fig. 3.

Referring to the drawings, 1 designates a drive shaft which is operated by steam or any other suitable source of power, on which is mounted a large drive wheel 2. On either side of the drive wheel 2 is a shaft 3, on which is mounted a small wheel 4 and a larger wheel 5. The smaller wheel 4 meshes with the drive wheel 2 and wheel 5 is operated by the shaft 3 which meshes with the small wheel 4 which is mounted on a shaft 7, which shaft carries a larger wheel 8. The wheel 8 meshes with a cog wheel 9 which operates a flexible shaft 10, which carries a

propeller 18. The lever 11 is pivoted, as at 12, and the shafts 10 are journaled in the lower ends of these levers 11. When it is desired to disengage the propeller from the operating mechanism, the screw-threaded member 13 is unscrewed until the lever 11 is free to move in the space 14 between the extremities of the bracket 15, which forms a guide in which the lever is operated.

As shown in Fig. 6, the lever 11 is moved inwardly and a screw 13 being inserted holds the same in an inoperative position. When it is desired to throw the propeller into engagement with the operating mechanism, the screw 13 is withdrawn and the lever 11 is moved into a vertical position, which causes the wheel 9 to mesh with the wheel 8, which causes the propellers to operate.

It will be seen that the screw 13 holds the propeller locked in either an operative or inoperative position, as desired.

The propeller shafts 10 pass through suitable stuffing boxes 16, through which said shafts project into the water. Each of the propeller shafts 10 is supported by an arm 17, through the lower portions of which the shafts extend.

In order to relieve the propeller from some of the strain incident to rapid movement, rods or braces 19 are provided which connect the outer ends of each of the propellers.

It will be seen that my invention is simple, inexpensive and durable and that exceedingly great speed can be developed when desired.

This propeller can be used on the sides of the boats, if desired, single or double.

Having described the invention, what I claim as new and useful and desire to secure by Letters Patent is:—

1. In a propelling mechanism of the class described, a pair of propelling shafts, one end of each shaft being mounted in a lever, a cog wheel carried by each shaft, means for operating said wheels, a substantially U-shaped bracket for the reception of the upper end of the lever, said bracket acting as a guideway for the operation of said lever whereby the propellers are thrown into and out of engagement, said bracket being provided with a screw threaded locking member penetrating the bracket, for holding the lever in either of two different positions, substantially as and for the purpose described.

2. In combination, a frame including a

revoluble chain of gears, arranged in the hull of a boat, a pair of flexible propeller shafts journaled in bearings in the stern of the boat and each provided with a gear wheel on one of its ends, a pair of levers, one pivoted on each side of said frame, in the lower short end of which levers the ends of the propeller-shafts are journaled, U-shaped metallic strap brackets arching over the upper portions of the levers and bolted to the frame, and a locking plug having a restricted portion threaded through each of the brackets, the restricted portions of the plugs constituting means for holding

the levers against one side or the other of the inside of the brackets, whereby the gears of the propeller shafts may be held in or out of mesh with two of the gears of the chain of gears, the levers being permitted to be moved by unscrewing the locking plugs.

In testimony whereof I have signed my name to this specification in the presence of two subscribing witnesses.

JOSEF R. FIALA.

Witnesses:

JOSEF KUDLAI,  
FR. J. FIALA.

---

Copies of this patent may be obtained for five cents each, by addressing the "Commissioner of Patents, Washington, D. C."

---