

No. 718,967.

PATENTED JAN. 27, 1903.

W. B. ALFORD.  
WATER MOTOR.

APPLICATION FILED AUG. 13, 1902.

NO MODEL.

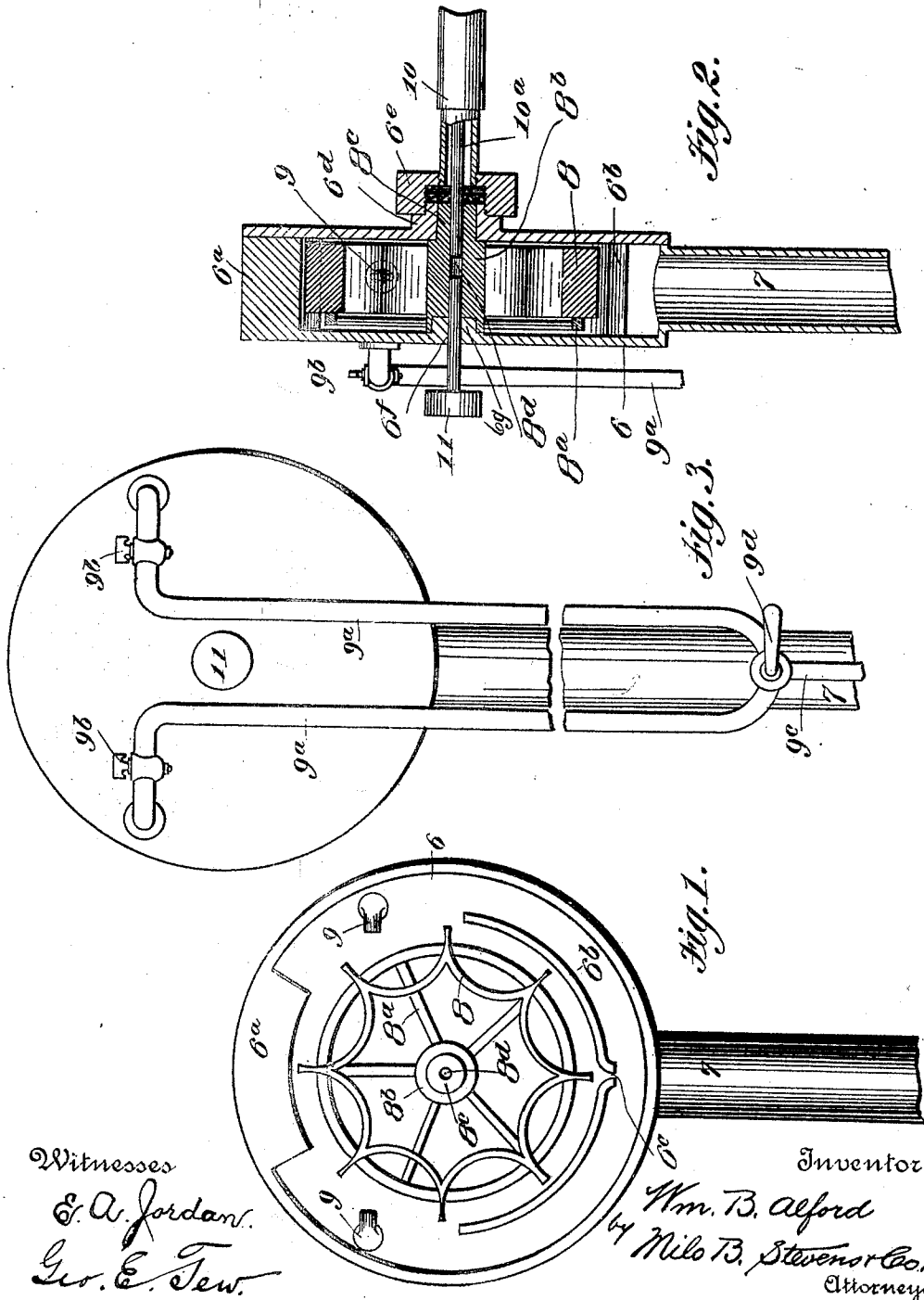

Witnesses  
E. A. Jordan.  
Geo. E. Tew.

Inventor  
Wm. B. Alford  
by Milo B. Stevens & Co.  
Attorneys.



# UNITED STATES PATENT OFFICE.

WILLIAM BASKIN ALFORD, OF SUMTER, SOUTH CAROLINA.

## WATER-MOTOR.

SPECIFICATION forming part of Letters Patent No. 718,967, dated January 27, 1903.

Application filed August 13, 1902. Serial No. 119,492. (No model.)

*To all whom it may concern:*

Be it known that I, WILLIAM BASKIN ALFORD, a citizen of the United States, residing at Sumter, in the county of Sumter and State of South Carolina, have invented certain new and useful Improvements in Water-Motors; and I do hereby declare the following to be a full, clear, and exact description of the invention, such as will enable others skilled in the art to which it appertains to make and use the same, reference being had to the accompanying drawings, and to the figures of reference marked thereon, which form a part of this specification.

This invention relates to water-motors, particularly to that class thereof used by dentists for the purpose of driving their instruments and tools.

The general object of the invention is to simplify and improve the construction of such motors.

The particular object is to dispense with bands and cogs, with resulting saving of power, by connecting the flexible shafting direct to the motor. By this means the motor can be made smaller than would otherwise be the case and also more convenient to use.

Referring to the accompanying drawings, Figure 1 is a front elevation of the motor with the face plate or cover removed. Fig. 2 is a vertical cross-section of the motor. Fig. 3 is a rear elevation thereof.

Referring specifically to the drawings, 6 indicates the casing forming the wheel-chamber, which is extended at the top, as at 6<sup>a</sup>, to form a partition, which approaches the circumferential line of the water-wheel and serves to prevent splashing. Under the wheel and nearly in contact therewith is another partition, (indicated at 6<sup>b</sup>,) which acts to convey the dead-water to the outlet 7 and to prevent such water from backing up or splashing into the path of the wheel. This partition 6<sup>b</sup> is provided with a small drip-opening 6<sup>c</sup>, which lets off any water which may happen to be carried within or above the partition. The partition extends entirely across the casing from the front to the back thereof and forms an arc concentric with the wheel and extending somewhat less than half the circumference. The wheel comprises blades 8, forming buckets therebetween, which are supported

on a spider 8<sup>a</sup>, secured to the hub 8<sup>b</sup>. The inlet-nozzles for the water come through the back of the casing and are indicated at 9. They are flattened, as shown in dotted lines in Fig. 2, with the longer axis extended vertically. I have found that a nozzle of this shape gives a much more forcible impact-spray than a round nozzle. These nozzles are located above the level of the hub and are directed inwardly and substantially horizontally toward the wheel. The water is thus carried over the wheel and exerts its force for about half the circumference of the wheel. It is discharged from the wheel outside or beyond the partition 6<sup>b</sup>, which prevents it from again coming in contact with the wheel. The wheel is thus caused to run very cleanly, with little or no splashing or back pressure, and less water-pressure is needed than would otherwise be the case. The hub of the wheel is extended, as at 8<sup>c</sup>, through a nipple 6<sup>d</sup> on the front plate of the casing, and this nipple is threaded to receive a packing-nut 6<sup>e</sup>, to which the shaft covering or cable 10 is attached. The hub of the wheel is hollow, as at 8<sup>d</sup>, to receive the end 10<sup>a</sup> of the flexible shaft, which may be made non-rotatable therein in any proper manner, as by squaring, or a key.

It will be seen that the driven flexible shaft is directly connected to the motor and may be readily disconnected by taking off the nut 6<sup>e</sup> and pulling the shaft out of the hub. No power is lost in belts or cogs or other transmission devices.

The back of the casing has an inner central circular boss 6<sup>f</sup>, forming a bearing for the hub, and said boss has an opening 6<sup>g</sup>, registering with the hollow of the hub, through which opening the stem of a brush-wheel may be inserted, as indicated at 11, for the purpose of cleaning burs or other instruments. This will be found very convenient and useful, as the tools can be cleaned while at work without disconnecting the flexible shaft.

The water-supply fittings comprise two pipes 9<sup>a</sup>, each of which communicates through the back of the casing with one of the nozzles 9. Each pipe has a cock 9<sup>b</sup> for the purpose of regulating the water pressure and flow. Below the cocks the pipes join to form a single pipe 9<sup>c</sup>, which joint has a two-way foot-cock, (indicated at 9<sup>d</sup>.) This construction

permits the water-pressure to be regulated or set in advance, after which the use of the operator's hands is not necessary, as he can reverse the motor or stop the same by appropriate movement of the foot. It will be seen that the stoppage or reversal of the motor does not affect the pressure adjustment at which the cocks 9<sup>b</sup> are set. The pipes are conveniently hose, as will be understood, to accommodate the movement of the chair, inasmuch as it is intended that the motor shall be attached to the arm or other part thereof.

What I claim as new is—

The combination with a casing, of a water-wheel therein having a hollow hub, said cas-

ing having on one side an opening provided with a nipple through which the hub extends, and having on the other side a central, inwardly-projecting circular boss forming a bearing for the hub, with a shaft-opening through the boss registering with the hollow of the hub, whereby two shafts may be attached.

In testimony whereof I affix my signature in presence of two witnesses.

WM. BASKIN ALFORD.

Witnesses:

H. G. OSTEEN,

D. W. CUNNINGHAM.