

[54] **SMALL ELECTRICAL APPARATUS
POWERED BY INDUCTION COOKING
APPLIANCES**

[75] Inventors: **John D. Harnden, Jr.; William P. Kornrumpf**, both of Schenectady, N.Y.

[73] Assignee: **General Electric Company**, Schenectady, N.Y.

[22] Filed: **Mar. 1, 1972**

[21] Appl. No.: **230,732**

[52] U.S. Cl. **219/10.49, 219/10.75**

[51] Int. Cl. **H05b 5/04**

[58] Field of Search **219/10.49, 10.75, 219/246, 259, 242; 321/10**

[56] **References Cited**

UNITED STATES PATENTS

3,710,062 1/1973 Peters 219/10.49

2,415,688	2/1947	Hall	219/246
2,133,494	10/1938	Waters.....	219/10.49
3,530,499	9/1970	Schroeder.....	219/10.49
3,320,512	5/1967	Kruger.....	321/10

OTHER PUBLICATIONS

Mapham, "Low Cost, Ultrasonic Frequency Inverter Using a Single SCR", Application Note 200.49, General Electric, 2/1967.

Primary Examiner—Bruce A. Reynolds

Attorney—John F. Ahern et al.

[57] **ABSTRACT**

Induction surface cooking units are used to supply voltage to specially modified cordless auxiliary kitchen appliances and other small electrical apparatus, either motorized or resistive, placed on the counter-top cooking surface. In similar fashion a universal energizer unit comprises an inductively coupled receptor coil and rectifier with plug-in receptacles for other equipment.

5 Claims, 12 Drawing Figures

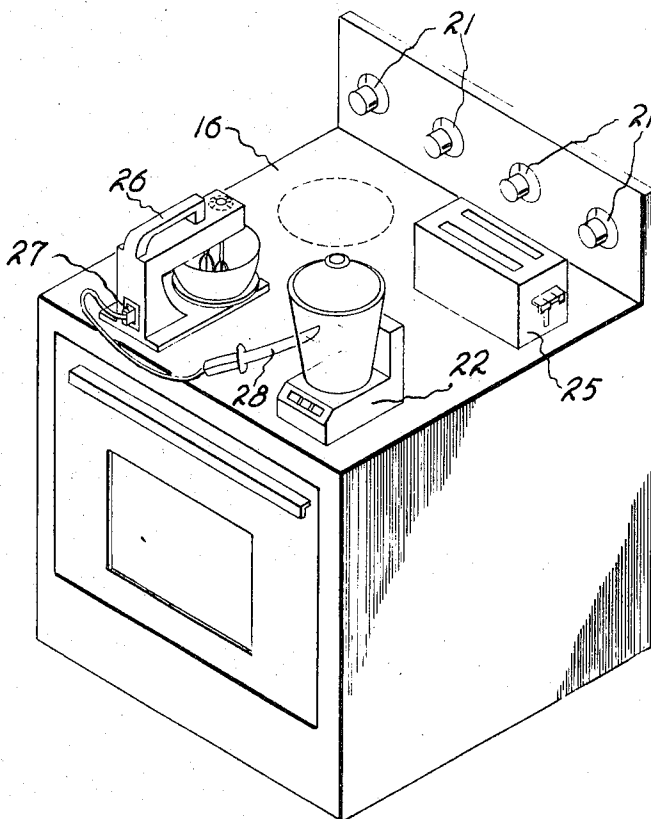

Fig. 1

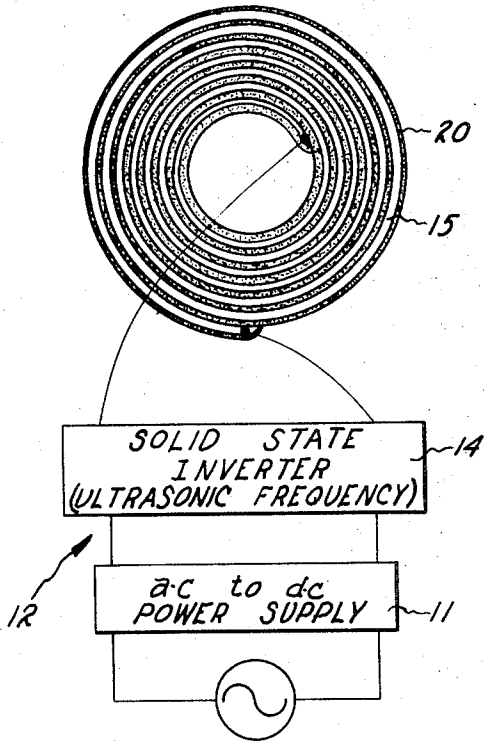

Fig. 2

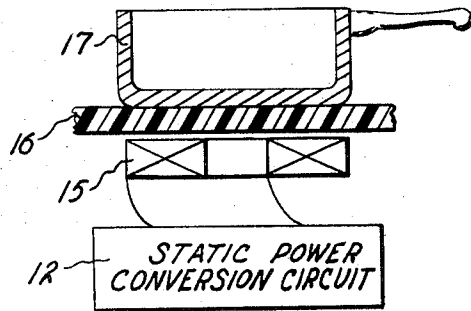
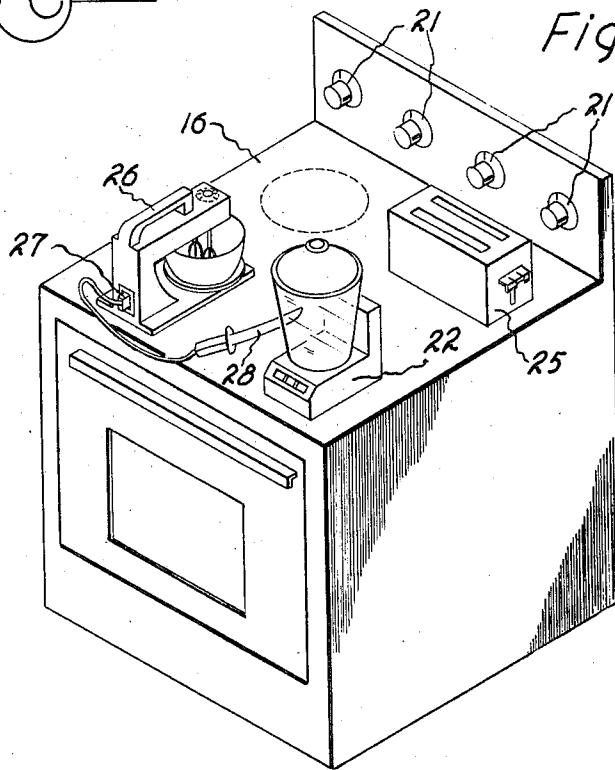

Fig. 3



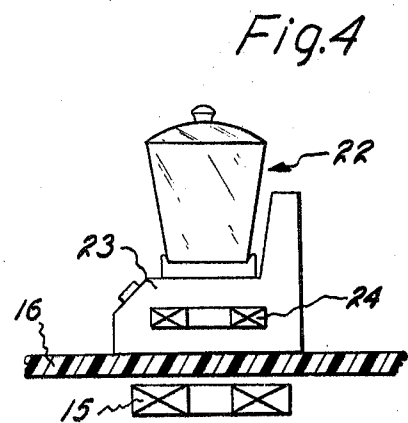
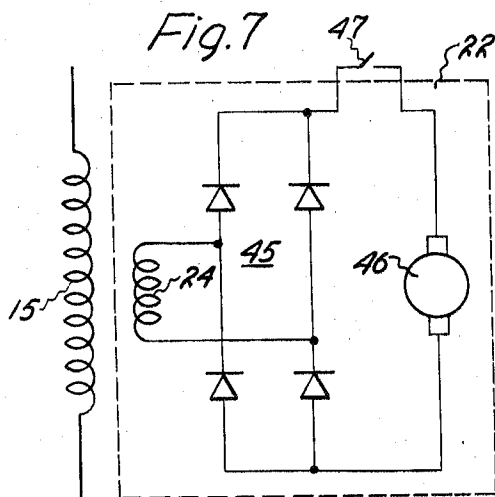
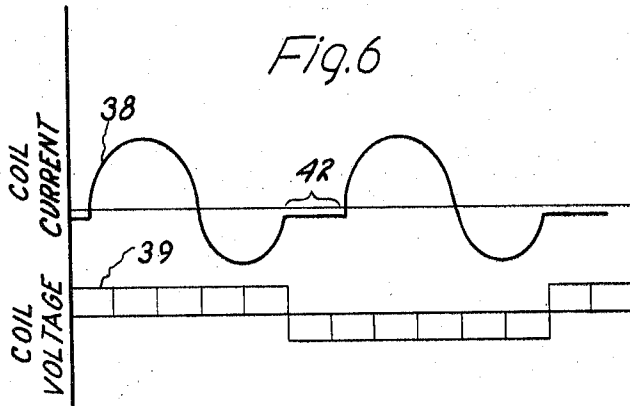
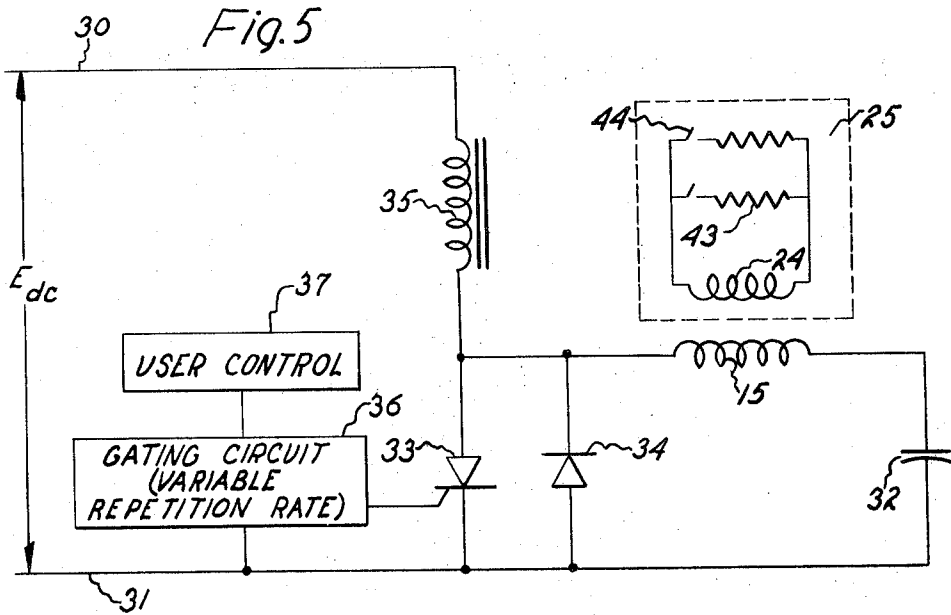

Fig. 8

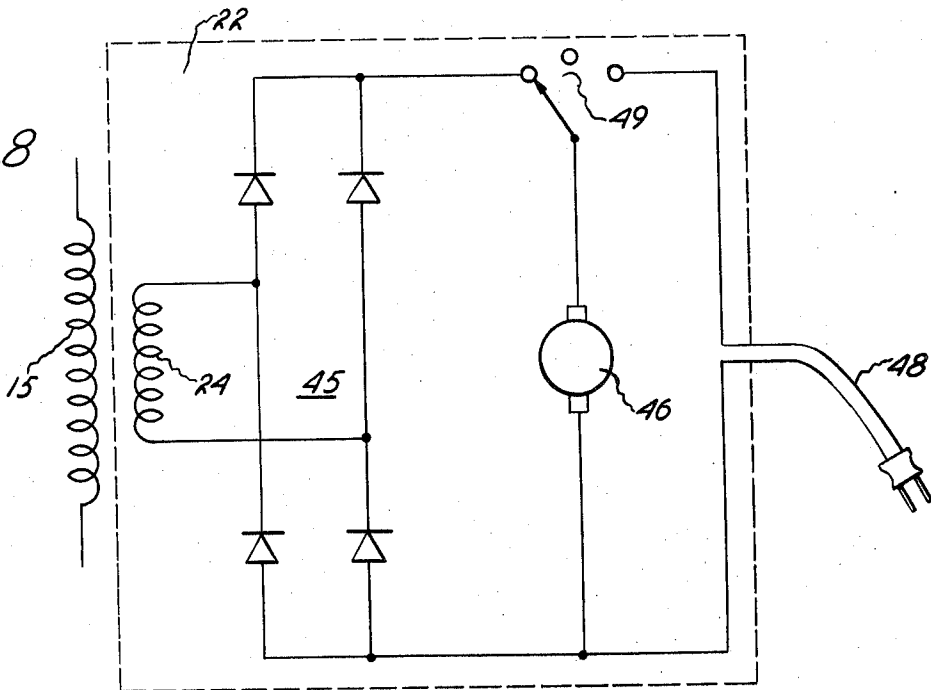

Fig. 9

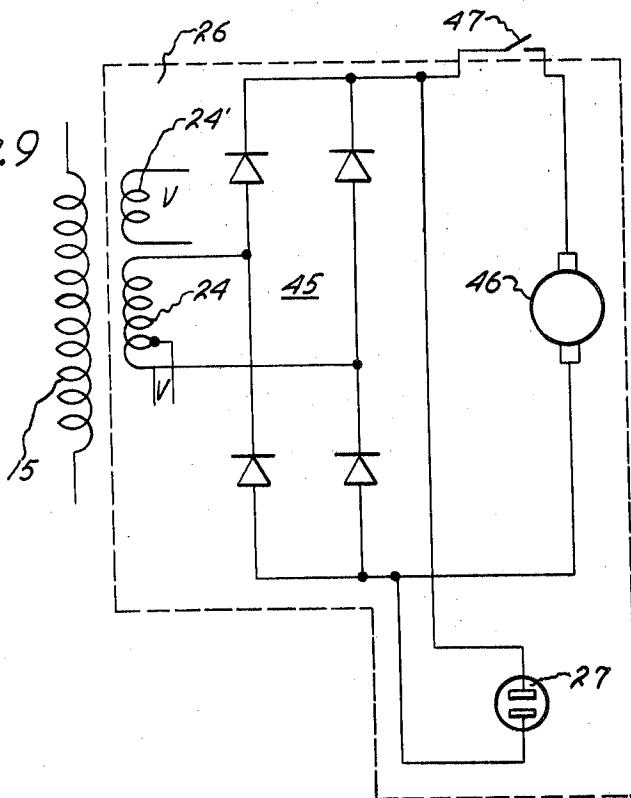

Fig.10

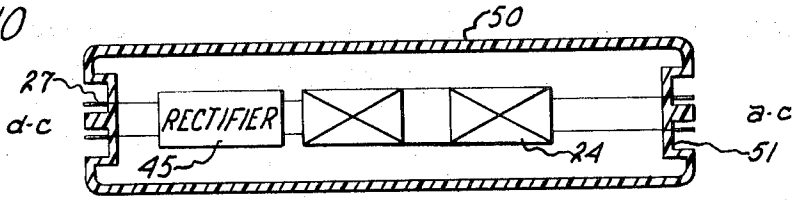

Fig.11

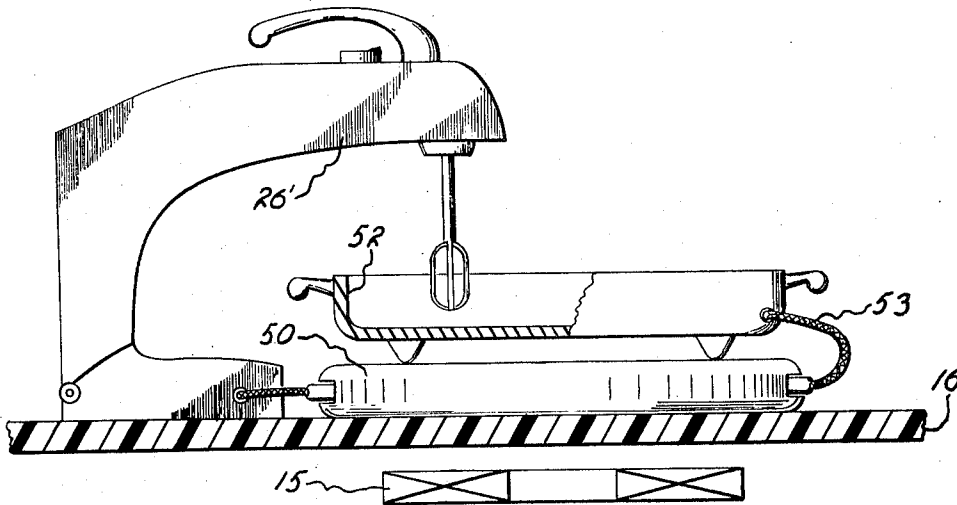
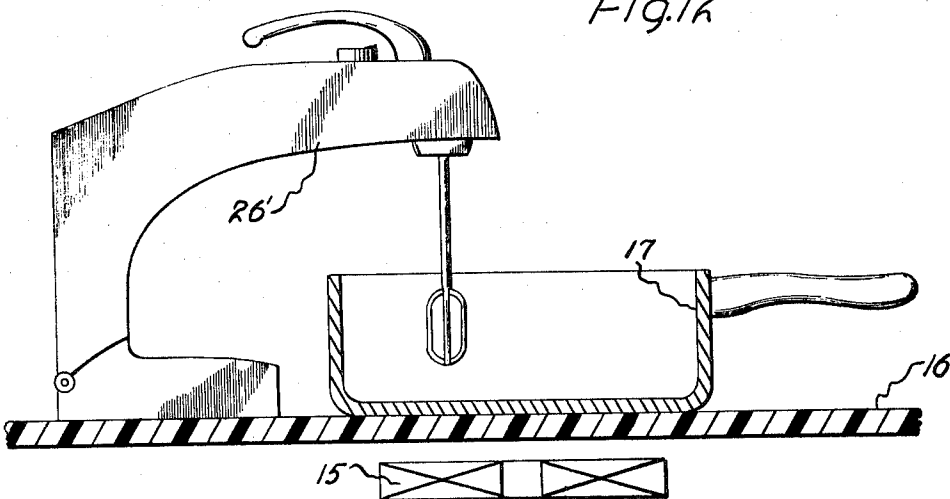

Fig.12



SMALL ELECTRICAL APPARATUS POWERED BY INDUCTION COOKING APPLIANCES

BACKGROUND OF THE INVENTION

This invention relates to the use of counter-top induction surface cooking units to supply electrical power to a variety of small electrical apparatus such as auxiliary kitchen appliances, and to small electrical apparatus equipped for energization in this manner.

The concept of applying induction heating to the cooking of food was not potentially competitive with the common gas range and resistance heating electric range until the development of ultrasonic frequency solid state appliances. These cool-top cooking units, as they are commonly known, have such desirable user features as an unobstructed, cool, clean wipe cooking surface; fast utensil warm-up; responsive heating with lower power requirements; complete freedom to move the utensil; and noiseless operation. The present invention recognizes that the coupling of power across an air gap is not restricted to the generation of heat in metallic sheets such as the bottom of a cooking utensil, but can also be used to couple power to a receptor coil for powering a variety of small apparatus and auxiliary appliances useful in a kitchen.

Among the unsuccessful prior attempts were the low frequency eddy current cookers employing a circular arrangement of alternately poled permanent magnets rotated by an electric motor. Eddy current cookers are described, for example, in U.S. Pat. No. 3,085,142 to M. Baermann. It is taught in German Pat. No. 1,168,582 that this equipment can be used to actuate mechanical rotation in a blender or mixer by means of a simple magnetic rotor that follows the rotating magnetic field. However, there are obvious limitations as to the type of auxiliary appliance suitable to be driven in this manner.

SUMMARY OF THE INVENTION

Induction cooking units used in the practice of the invention have a cool, counter-top cooking surface and include an induction heating coil driven by a static power conversion circuit which generates an alternating magnetic field. The static power converter preferably comprises a solid state inverter operated at ultrasonic frequencies to supply controlled power to the induction heating coil. As herein taught, a cordless small electrical apparatus is supported on the counter-top cooking surface and comprises a receptor coil inductively coupled with the induction heating coil that generates an electrical voltage. The principal utility of the invention is to energize small resistive kitchen equipment such as a toaster and motorized auxiliary appliances such as a blender or mixer. The latter commonly use a universal motor and it is necessary to use a rectifier to convert the high frequency voltage to a direct voltage for running the universal motor. Resistive equipment, on the other hand, does not require use of a rectifier. The equipment can include an auxiliary receptacle into which other appropriate small appliances and apparatus can be plugged. Another embodiment is a universal energizer unit with both a-c and d-c receptacles. Energization in this manner is safe to the user because of the isolated voltage supply, and there is no danger of damaging extension cords on the cool-top range, and subsequent user harm, as with the common resistance heating range. Further, power-assisted cook-

ing is made possible, as for instance using an electric mixer to mix food as it is being cooked.

BRIEF DESCRIPTION OF THE DRAWINGS

FIG. 1 is a plan view of a flat spiral induction heating coil and a block representation of a solid state power conversion circuit for supplying ultrasonic frequency power to the coil;

FIG. 2 is a diagrammatic cross-sectional view showing the relation of the induction heating coil to the cooking surface and cooking utensil;

FIG. 3 is a perspective view of a cool counter-top electric range supplying power to a toaster, a blender, and a mixer, with an electric knife plugged into a receptacle on the mixer support post;

FIG. 4 is a cross-sectional view similar to FIG. 2 illustrating the induction heating coil coupled with a receptor coil in the blender stand;

FIG. 5 is a schematic circuit diagram of one form of inverter suitable for an induction surface cooking unit, and of the electrical circuitry of a small resistive apparatus such as a toaster that derives power from the cooking unit;

FIG. 6 shows two types of suitable inverter waveforms;

FIG. 7 is a schematic circuit diagram of a motorized auxiliary kitchen appliance equipped to be powered by an induction cooking unit;

FIG. 8 is a modification of FIG. 7 with provision to optionally energize the auxiliary appliance by plugging into a wall receptacle;

FIG. 9 is another modification of FIG. 7 with the additional feature of a energizer with a receptacle into which other small appliances can be plugged, such as the electric knife in FIG. 3;

FIG. 10 is a schematic cross section of a universal energizer unit with both a-c and d-c receptacles;

FIG. 11 is an elevation view, partly in cross section, illustrating the use of the energizer unit of FIG. 10 to facilitate mixing of food as it is being cooked in an electric saucepan; and

FIG. 12 is similar to FIG. 11 but shows power mixing of food being cooked in the ordinary manner in a cooking utensil.

DESCRIPTION OF THE PREFERRED EMBODIMENTS

The induction cooking appliance shown in FIGS. 1-3 will be described with regard to an induction surface cooking unit in an electric range or cooktop, but essentially the same mechanical structure and electronic circuitry in higher and lower power versions is suitable for commercial cooking equipment and for a portable counter-top food cooking or warming appliance. The static power conversion circuit indicated generally at 12 is preferably energized by a single phase commercially available 60 Hz, 120 or 240 volt source of alternating voltage. Static power converter 12 comprises a solid state a-c to d-c power supply 11 including a full wave rectifier and a filter network for producing a d-c supply voltage that is converted by a solid state inverter 14 to an ultrasonic frequency voltage wave for driving the induction heating coil 15. Induction heating coil 15 is a single layer, annular, flat spiral, air-core or ferromagnetic-core coil wound with braided ribbon conductors or solid flat strip conductors. To generate sufficient magnetic flux to heat the utensil to the desired

level, coil 15 is tightly wound with the short cross-sectional dimension of the conductors facing upwards and adjacent turns separated by a flat insulating strip 20.

In the cooking appliance (FIG. 2), induction heating coil 15 is appropriately mounted in a horizontal position immediately below a non-metallic or substantially non-metallic support plate 16, typically made of a thin sheet of glass or plastic. Plate 16 supports the metallic cooking utensil 17 to be heated, and is hereafter referred to as the counter-top cooking surface. Cooking utensil 17 is an ordinary cooking pot or pan, a frying pan, or some other available metallic utensil used in food preparation (including metallic sheets), and can be made of magnetic or non-magnetic materials. Special cooking utensils are not required although the best and most efficient results are obtained by optimizing the size, shape, and material of the utensil. Operation of static power converter 12 to impress an ultrasonic frequency wave on induction heating coil 15 results in the generation of an alternating magnetic field. The magnetic flux is coupled across the air gap through the non-metallic cooking surface 16 to utensil 17. At ultrasonic operating frequencies in the range of 18 to 40 kHz the cooking appliance is inaudible to most people.

As shown in FIG. 3, an important feature of induction cooking equipment is that counter-top cooking surface 16 is relatively smooth and substantially continuous and unbroken. At ultrasonic frequencies there are insignificant reaction forces of either attraction or repulsion which at lower frequencies would cause utensil 17 to move when placed on the cooking surface approximately centered with respect to one of the induction surface unit positions indicated in dotted lines. The user therefore has complete freedom to move the utensil on the cooking surface. Control knob 21 for each unit on the upstanding control panel of the range turns the individual unit on and off and sets the desired heating level or specific temperature or power level in watts to which the utensil is to be heated. Among the advantages of induction cooking are, briefly, that the counter-top cooking surface 16 remains relatively cool; spilled foods do not burn and char and hence both surface 16 and utensil 17 are easy to clean; and the unobstructed cooking surface is immediately available for other food preparation and cooking tasks. The utensil is heated more uniformly than is the case with the conventional gas range or electric resistance heating range, and transfer of energy to utensil 17 is relatively efficient and consistent, not degrading with pan and source condition, since heat is generated only in the utensil where it is wanted. Further, since this is a low thermal mass system and there is thus a relatively low storage of heat in the cooking utensil, the heating level or temperature to which the utensil is heated can be changed rapidly, as from boiling to simmering to warming levels.

Further information on these and other features of cool-top induction surface cooking units is given in copending application Ser. No. 212,351, filed on Dec. 27, 1971, by John D. Harnden, Jr. and William P. Kornrumpf. As is there discussed, the load for inverter 14 is provided by the electrical losses in the utensil. With respect to the utensil load, induction heating coil 15 functions as the primary winding of an air-core transformer. In a physical equivalent circuit for utensil 17, the utensil functions as a single turn secondary winding with a series resistance connected between the ends of the sin-

gle turn representing the I^2R or eddy current losses, and hysteresis losses where applicable. The currents and voltages induced in the bottom of utensil 17 are determined essentially by transformer laws.

The present invention recognizes that the use of counter-top induction cooking units to couple electrical power across an air gap is not restricted to the generation of circulating currents in flat plates and sheets. By coupling the power to a multi-turn receptor coil functioning as the secondary winding, a source of voltage is provided to energize a variety of small electrical apparatus useful in the kitchen including such items as a blender, a mixer, an ice crusher, an electric knife, a toaster, and an energizer with one or more plug-in receptacles. By way of example, in FIG. 3 there is shown a small motorized auxiliary kitchen appliance in the form of a cordless blender 22 that is placed on the counter-top cooking surface 16, which is not at this time being used for cooking, and supplied with power by the underlying induction heating coil. Referring to FIG. 4, the blender base 23 includes a multi-turn flat or nominally flat receptor coil 24 oriented approximately horizontally so as to have a good inductive coupling with induction heating coil 15. The amount of extracted power is usually small relative to the maximum available power, but it is apparent that substantial power can be transferred in this manner if desired. Receptor coil 24 is usually a flat spiral coil but can have other configurations depending on such factors the power transferred. Resistive apparatus or appliances such as toaster 25 can also be supplied with power by the induction heating coil. Another application of the concept is that the small appliance or apparatus can be in the form of, or can be provided with, an energizer unit with one or more plug-in receptacles into which other appliances or apparatus can be plugged. Thus in FIG. 3 the stand of electric mixer 26 has an electrical receptacle 27 into which a knife 28 is plugged. A separate universal energizer unit is illustrated in FIGS. 10 and 11.

As was previously mentioned, the unobstructed, unbroken, counter-top cooking surface 16 is available for other food preparation tasks such as opening cans, cutting and trimming vegetables, and so on. The powering of auxiliary appliances and apparatus as herein taught extends the range of usefulness of the counter-top cooking surface, and makes it more desirable to perform the other food preparation tasks on it because of the availability of power appliances. Power appliances equipped for energization by inductively coupled power are inherently more safe than being energized by plugging into a wall or range receptacle because the power supply is isolated and hence there is no shock hazard due to ground fault currents. There is a higher degree of user willingness to use these appliances since there are no associated cords, and no hot, exposed resistance heating coils or flames that deter the average person from using power appliances around present ranges due to the danger of fraying and melting the cord insulation. Indeed the concept of simultaneous cooking and small appliance working in concert is believed to be a significant new mode of food preparation, virtually avoided and discouraged by present concepts and practices. In addition to being advantageous in space-restricted kitchens, the invention is useful in vacation cottages and camps where the number of electrical outlets may be restricted or non-existent. Inverter

14 can be powered by a battery or other similar source of energy, and may thus be the only available source of power for operating other small electrical equipment such as a light bulb or lamp, a fan, or an electrical shaver.

To understand the remainder of the circuitry besides receptor coil 24 in a small appliance or apparatus equipped for powering by an induction cooking unit, it is of benefit to discuss inverter 14 and the waveforms generated by the various inverters that can be employed in these cooking units. FIG. 5 shows by illustration one of the many different embodiments of inverter 14 that can be used in the practice of ultrasonic frequency induction cooking. This one-thyristor series resonant inverter requires a small number of components, only one gating circuit and produces a wide range of output power levels and corresponding utensil heating levels. Only a brief description of the construction and operation will be given in view of the discussion in the aforementioned application as well as in Kornrumpf application Ser. No. 200,530 filed on Nov. 19, 1971, now U.S. Pat. No. 3,697,716, dated Oct. 10, 1972, which shows the same inverter configuration. Inverter 14 comprises a unidirectional conducting power thyristor 33 connected in series circuit relationship with a reset inductor 35 between input terminals 30 and 31. A constant or variable direct voltage E_{dc} is supplied to d-c terminals 30 and 31. A diode 34 to conduct power current in the reverse direction is connected across the load terminals of thyristor 33. A series RC circuit is also usually connected across the load terminals of thyristor 33 for dv/dt protection to limit the rate of reapplication of forward voltage to the device. The basic power circuit is completed by induction heating coil 15 and a commutating capacitor 32 connected in series with one another and coupled directly across the terminals of the inverse-parallel combination of thyristor 33 and diode 34. When either of the power devices is conducting, capacitor 32 and induction heating coil 15 form a series resonant circuit for generating damped sinusoidal current pulses that flow through induction heating coil 15, which has the dual function of providing commutating inductance as well as coupling power to the load. Reset inductor 35 functions to reset the commutating capacitor by charging commutating capacitor 32 positively during the non-conducting intervals of the thyristor-diode combination. Each cycle of current flow is initiated by a gating pulse applied to thyristor 33 by a variable repetition rate gating circuit 36. A user control 37, for example, an adjustable potentiometer actuated by control knob 21 on the range control panel (FIG. 3), sets the repetition rate of gating circuit 36.

Turning on the induction surface unit applies d-c voltage to inverter 14 and conditions the high frequency resonant circuit for operation by charging commutating capacitor 32 positive as to the plate coupled to positive d-c input terminal 30 and negative as to the plate coupled to d-c terminal 31. The application of a gating pulse to thyristor 33 by main gating control circuit 36 causes it to turn on, energizing the series resonant circuit essentially comprising commutating capacitor 32 and induction heating coil 15. A damped sinusoidal current pulse flows through induction heating coil 15 and charges commutating capacitor 32 negatively. At this point the current in the series resonant circuit reverses and a damped sinusoidal current pulse

of the opposite polarity flows through induction heating coil 15 and diode 34. During the time that feedback diode 34 is conducting thyristor 33 is reverse biased by the voltage across diode 34 and turns off. When the current in the series resonant circuit again attempts to reverse, thyristor 33 does not conduct since it has regained its forward voltage blocking capabilities, and a gating pulse is not applied to the thyristor at this time. Because of the losses in the electrical circuit due to the heating of utensil 17, commutating capacitor 32 at the end of the complete conduction cycle on a steady state basis is left charged to a lower voltage than it had at the beginning of the oscillation.

While either of main thyristor 33 and diode 34 are conducting, reset inductor 35 is connected between the d-c supply terminals 30 and 31, and accordingly current builds up in inductor 35. During the circuit off-time when both of power devices 33 and 34 are non-conducting, the energy stored in reset inductor 35 is discharged and transferred primarily to commutating capacitor 32, thereby leaving commutating capacitor 32 with a net positive charge at the end of the circuit off-time or energy transfer period. Waveform 38 in FIG. 6 shows the asymmetrical sinusoidal induction coil current for two complete cycles of operation separated by a time delay interval 42 corresponding to the energy transfer period. A small current circulates in coil 15 during the energy transfer period due to the recharge current of capacitor 32. The function of reset inductor 35, it is seen, is to replenish the high frequency system energy and sustain circuit oscillation. With practical component choices the circuit transfers more energy from reset inductor 35 to commutating capacitor 32 as the transfer period is made shorter, relative to the high frequency oscillation period. There are thus two effects that increase the power in watts supplied to the load when the inverter operating frequency or repetition rate is increased. There are larger as well as more frequently applied current pulses in induction heating coil 15.

Other sine wave series and parallel resonant inverters and multicylinder inverters are suitable for use in induction surface cooking units, whether generating asymmetrical or symmetrical output waveforms, or continuous or discontinuous waveforms. The square or quasi-square waveform 39 is typically produced by a full bridge inverter and is advantageous because of the ability to obtain power control by pulse width modulation techniques. With any of these inverter output waveforms it is emphasized that for noiseless operation the feasible operating frequency range is preferably 18-40 kHz. At these frequencies the ponderomotive forces are insignificant and there are otherwise insignificant attractive and repulsive forces so that the inductively powered auxiliary equipment is freely movable on the cooking surface.

Small resistive equipment placed on counter-top 16 can be operated directly from the high frequency field produced by induction heating coil 15. The resistive element therefore is simply connected across receptor coil 24 with an optional switch to control the application of the current to the resistive element. In FIG. 5 the simplified electrical circuit of cordless toaster 25 is represented by a pair of parallel resistances 43 each connected in series with a switch 44 across the ends of receptor coil 24. The physical parameters of coil 24 including the number of turns are selected to give the de-

sired voltage and, if desired, to provide the proper impedance matching. Because of the presence of the cool cooking surface and the absence of an extension cord on the toaster 25 there is no reluctance on the user to cook at one unit position while simultaneously using the toaster at an adjacent unit position. In similar fashion a lamp for use with battery powered induction cooking units in camps and cottages is simply connected between the ends of receptor coil 28, with or without an extension cord for the lamp and on-off switch.

The motorized auxiliary appliances, which commonly use a universal motor, require the addition of a simple rectifier between receptor coil 24 and the motor. Referring to FIG. 7, the electrical circuitry in the stand 23 of blender 22 (see FIGS. 3 and 4) preferably includes a simple full wave bridge rectifier 45 for converting the high frequency voltage wave induced in receptor coil 24 to a unidirectional voltage that operates universal motor 46. Ordinarily a user switch 47 controls the application of voltage to the motor. A full wave rectified sinusoidal voltage such as waveform 38 in FIG. 6 is integrated by the motor windings. Available standard motors can be used when the voltage supplied to the motor is 120 volts. The use of a rectifier is not required, of course, when the auxiliary appliance is equipped with a suitable high frequency motor.

The modification shown in FIG. 8 is that the motorized auxiliary appliance, such as blender 22, can optionally be equipped for energization in the ordinary manner from a wall receptacle supplied with standard utility voltage. Universal motors, of course, can be operated by either direct voltage or by single phase alternating voltage. The electrical circuit is modified only to the extent of connecting across universal motor 46 an extension cord 48 terminated by an electrical plug. The double-throw switch 49 is provided so that the user can select between two positions according to whether the appliance is used in the standard manner or by deriving power from the induction cooking unit.

The optional feature shown in FIG. 9 is the addition of a plug-in receptacle 27 to the base or upright support of the auxiliary appliance so that additional pieces of electrical equipment or other auxiliary appliances can be plugged in. This has already been discussed briefly with regard to FIG. 3 in that mixer 26 has an auxiliary receptacle 27 into which electric knife 28 is plugged. In the circuit the terminals of receptacle 27 are connected across the d-c output terminals of bridge rectifier 45. Small auxiliary kitchen appliances with a universal motor can be energized by this voltage supply. To obtain an auxiliary source of voltage that is a fraction of the total voltage across receptor coil 24, coil 24 can be tapped to provide an auxiliary voltage V. Depending on the intended application, it is usually necessary to full wave rectify the tapped voltage V. Another technique for obtaining an auxiliary source of voltage is to use an auxiliary pick-up receptor coil 24' which can be a flat or cylindrical coil. In either case, an energizer unit comprising only receptor coil 24, full wave rectifier 45, and one or more receptacles 27 can be provided into which other conventional, unmodified resistive electrical equipment or motorized appliances with universal motors or appropriate high frequency motors can be plugged.

Changing the power output of inverter 14 in FIG. 5 by varying the repetition rate of gating circuit 36 results

in the application of increased voltages to induction heating coil 15 as the repetition rate is increased, and lower voltages as the repetition rate is decreased. Consequently the voltage across receptor coil 24 is also variable. Controlling the power output of the induction cooking unit by adjusting control knob 21, then, changes the speed of motor 46 in a motorized small appliance or adjusts the temperature or watts in resistive type equipment and appliances. Control of the motor speed from the cooking unit is one of the new features made possible by the invention. To the extent that the necessary controls are provided on the range or cooktop, they need not be duplicated on the small appliance. In the foregoing discussion it is understood that the appliances and electrical apparatus are conventional and modified only as indicated, and that the motorized appliances in known manner rotate or reciprocate a work element.

The universal energizer unit 50 shown in FIG. 10 has a flat disk shape and is provided with both a-c and d-c outlets. Energizer 50 is thus suitable for supplying power to small resistive appliances and equipment as well as to motorized auxiliary kitchen appliances, either separately or in combination. Inside the non-metallic housing of the energizer unit is a flat receptor coil 24, an associated full wave rectifier 45, and a d-c receptacle 27 as described with regard to FIG. 9. In addition there is an a-c receptacle 51 with its terminals connected across the ends of receptor coil 24. Instead of making available high frequency a-c at receptacle 51, a simple cycloconverter can be used to supply 60 Hz power at the receptacle.

FIG. 11 illustrates the use of universal energizer unit 50 to implement the new power-assisted mode of cooking achieved by simultaneous operation of a small appliance as the cooking is performed, with the advantages of greater convenience and improved results. By way of example there is shown a resistance heated saucepan 52 with its extension cord 53 plugged into the a-c receptacle 51. A conventional, unmodified mixer 26' with a universal motor and an extension cord is plugged into d-c receptacle 27, in the same manner that electric knife 28 is energized in FIG. 3. At the same time that food is being cooked in saucepan 52, mixer 26' is operating to stir the food, as is required to properly cook some foods such as fudge and stew. Although the saucepan is shown placed on top of energizer unit 50, it is apparent that the mixer and saucepan can be used in concert at some other position on counter-top cooking surface 16. After the food is fully cooked, saucepan 52 can be removed from the range and then plugged into another receptacle for warming at a location remote from the range.

FIG. 12 shows the new power-assisted cooking technique in connection with the cooking of food in the usual manner, that is, utensil 17 is heated inductively by induction heating coil 15 in the same way as in FIG. 2. Mixer 26' is supplied with power either from universal energizer unit 50 or by plugging into a receptacle supplied with standard utility voltage, or mixer 26 powered by an adjacent unit can be used, and simultaneously mixes the food while it is cooking. This mode of cooking is discouraged by present ranges without a cool, counter-top cooking surface.

In summary, counter-top induction surface cooking units are used to energize inductively coupled small auxiliary kitchen appliances and other electrical appa-

ratus that are modified at least to the extent of incorporating a receptor coil in the flat base, and also a rectifier depending on the specific application. These auxiliary appliances and equipment are safe to the user due to the isolated power supply, and can include a receptacle to supply voltage to appropriate unmodified equipment. An energizer unit with plug-in receptacles is another feature of the invention.

While the invention has been particularly shown and described with reference to several preferred embodiments thereof, it will be understood by those skilled in the art that various changes in form and details may be made therein without departing from the spirit and scope of the invention.

What I claim as new and desire to secure by letters Patent of the United States is:

1. The combination comprising

an induction cooking appliance including a substantially non-metallic, unbroken, relatively smooth counter-top cooking surface, a nominally flat induction heating coil mounted adjacent said cooking surface for generating an alternating magnetic field, and a variable output power solid state inverter operating in the ultrasonic frequency range that drives said induction heating coil, and a small motorized kitchen appliance freely supported on said counter-top cooking surface and including a receptor coil inductively coupled with said induction heating coil that produces an electrical voltage for energizing said motorized kitchen appliance, said induction heating coil having the dual function of heating a food-containing cooking utensil and alternatively energizing said motorized kitchen appliance.

2. The combination according to claim 1 in which

said motorized kitchen appliance includes a universal motor and a full wave diode rectifier having input terminals connected to said receptor coil and output terminals connected to said universal motor.

3. The combination according to claim 2 in which said motorized kitchen appliance further includes an auxiliary unidirectional voltage electrical receptacle also connected to said rectifier output terminals.

4. The combination according to claim 1 in which said induction cooking appliance includes user controls coupled to adjust the output power of said inverter and consequently the magnitude of the electrical voltage energizing said motorized kitchen appliance.

5. The combination comprising an induction cooking appliance including a substantially non-metallic, unbroken, relatively smooth counter-top cooking surface, a nominally flat induction heating coil mounted adjacent said cooking surface for generating an alternating magnetic field, and a solid state inverter operating in the ultrasonic frequency range that drives said induction heating coil, and

a universal energizer unit freely supported on said counter-top cooking surface and including a nominally flat receptor coil, a full wave diode rectifier having input terminals connected to said receptor coil and output terminals connected to a unidirectional voltage electrical receptacle, and an alternating voltage electrical receptacle connected to said receptor coil,

said induction heating coil having the dual function of heating a food-containing cooking utensil and alternatively energizing said universal energizer unit.

* * * * *

40

45

50

55

60

65