

[54] **SLAG REMOVAL MECHANISM WITH FLUID SEAL**

[76] Inventor: **Johannes Josef Martin**, Leopoldstrasse 248, Munich, Germany

[22] Filed: **July 26, 1971**

[21] Appl. No.: **165,912**

[30] **Foreign Application Priority Data**

Aug. 5, 1970 Germany.....P 20 38 891.4

[52] U.S. Cl. ....**110/165 R, 110/171**

[51] Int. Cl. ....**F23j 1/00**

[58] Field of Search .....**110/165 R, 171**

[56] **References Cited**

**UNITED STATES PATENTS**

2,160,026	5/1939	Martin.....	110/171
2,037,990	4/1936	Martin.....	110/165
2,589,836	3/1952	Martin.....	110/165

Primary Examiner—Kenneth W. Sprague  
Attorney—Michael S. Striker

[57] **ABSTRACT**

A slag removal mechanism for fire boxes or the like is comprised of a fluid-containing slag receptacle into which a slag-dispensing chute extends through which the slag is deposited in the receptacle. A reciprocable pusher member is disposed in the slag receptacle and extending into the fluid for pushing the slag through the fluid towards the receptacle opening. The open end of the slag-dispensing chute extends into the fluid in the slag receptacle and a sealing arrangement is provided between the open end of the chute and the reciprocating pusher member to prevent admixture of the contaminated fluid portion in which the slag is suspended with the clean fluid portion rearwardly of the pusher member to thereby prevent entrance of dirt into the pusher mechanism.

**7 Claims, 5 Drawing Figures**

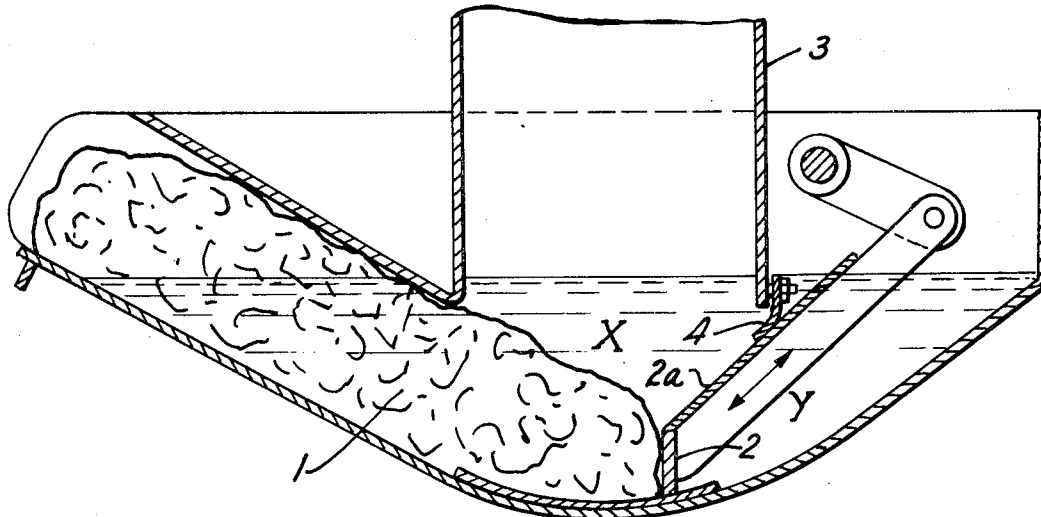

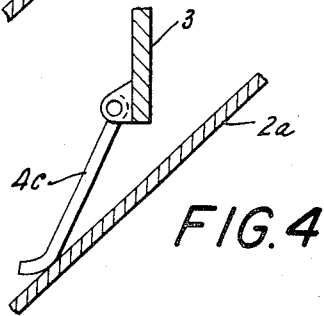
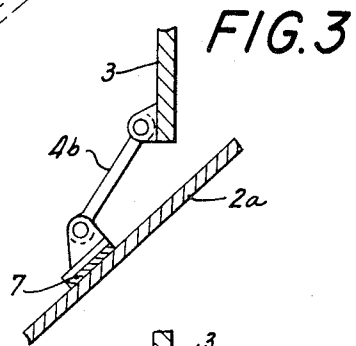
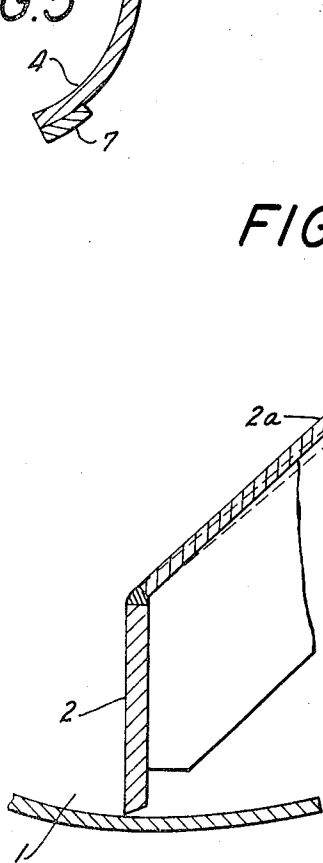
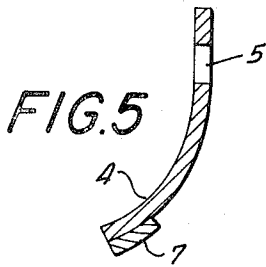
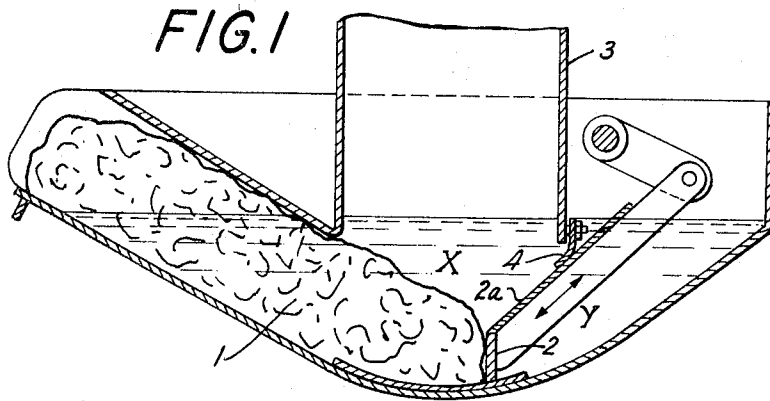

INVENTOR.  
JOHANNES JOSEF MARTIN  
BY  
Michael S. Stricker  
ATTORNEY

## SLAG REMOVAL MECHANISM WITH FLUID SEAL

### BACKGROUND OF THE INVENTION

The present invention refers to a slag-removal mechanism, in particular for fire boxes or the like, and in which the slag is suspended in a dust-absorbing fluid mechanism.

Slag removal mechanisms for fire boxes are known comprising a trough-like slag receptacle which is filled with water and into which a slag-dispensing member extends for deposit of the slag into the receptacle. The receptacle is provided with a slag-disposal opening and normally a pusher member is provided for reciprocation through the receptacle to intermittently move the slag out through the slag-disposal opening. In known arrangements of this type, a free space in the form of a slot or the like is provided between the open end of the slag-dispensing member and the bottom of the receptacle to permit reciprocation of the pusher member. This space permits contaminated fluid to enter behind the pusher member during the forward stroke due to back flow of the fluid medium. The contaminated fluid carries slag and dust particles behind the pusher member and into the pusher drive mechanism which causes considerable wear on the drive parts of the pusher mechanism and thus causes a reduction in effective life of the mechanism.

### SUMMARY OF THE INVENTION

Accordingly, it is the primary object of the present invention to provide in a slag-removal mechanism of the above type an improved sealing means between the slag-dispensing member and the pusher member to effectively prevent admixture of the contaminated fluid with the clean fluid during forward stroke of the pusher member, to thereby reduce or eliminate entrance of dirt into the drive mechanism of the pusher member.

The improvement of the present invention is incorporated in conventional slag-removal mechanisms for fire boxes and is comprised of a sealing member attached to the lower open end of the slag-dispensing member. The sealing member is in flexible sealing contact with the upper surface of a pusher member reciprocally arranged in a slag receptacle so as to effectively divide the slag receptacle into a dirty fluid chamber portion containing the slag and a clean fluid chamber portion behind the pusher member. By this arrangement an effective air-fluid seal is provided for preventing entrance of dirt into the drive mechanism of the pusher member, as well as prevention of introduction of air in case of a low fluid level in the slag receptacle. The improvement of the present invention provides a considerable technological advance and the life of the driving mechanism of the pusher member is considerably prolonged, while at the same time considerably reducing or completely eliminating any presence of slag or slush particles in the clean fluid portion of the slag receptacle behind and under the moving portions of the pusher member. The improved sealing arrangement of the present invention is constructed such as to be automatically adjustable to the various different positions of the pusher member during forward and backward stroke through the receptacle. The sealing arrangement of the present invention likewise accommodates for any wear on the pusher member during prolonged operation. In a further embodiment of the present invention the seal-

ing member may be provided with an interchangeable wear pad or surface to thereby further increase the useful life of the mechanism.

The novel features which are considered as characteristic for the invention are set forth in particular in the appended claims. The invention itself, however, both as to its construction and its method of operation, together with additional objects and advantages thereof, will be best understood from the following description of specific embodiments when read in connection with the accompanying drawing.

### BRIEF DESCRIPTION OF THE DRAWING

FIG. 1 schematically illustrates in cross-section a representative slag-removal mechanism embodying the present improved sealing means;

FIG. 2 is an enlarged fragmentary illustration of portions of FIG. 1 showing the improved sealing means in greater detail;

FIG. 3 illustrates a further embodiment of the sealing means in accordance with the present invention;

FIG. 4 illustrates still another embodiment of sealing means in accordance with the present invention; and

FIG. 5 illustrates yet another embodiment of sealing means in accordance with the present invention.

### DESCRIPTION OF THE PREFERRED EMBODIMENTS

With reference now to the drawings, and particularly FIG. 1, it will be seen that reference numeral 1 indicates a slag receptacle in the form of a trough which is partly filled with fluid, such as water. As shown, the receptacle 1 has an opening to the left in the Figure through which the slag is moved for disposal as will be described further on. A slag-dispensing member in form of a chute 3 extends into the receptacle 1 from above and has a lower end opening which is submerged in the water of the receptacle.

Receptacle 1 further contains a pusher member 2 in the form of a reciprocating arm drivingly connected at one end to a known driving mechanism, such as a crank or the like. The pusher member 2 is supported in slag receptacle 1 such as to extend partially underneath the lower end opening of the slag chute 3 for movement of the slag towards the receptacle opening seen at the left in the Figure.

The pusher member 2 has an upper wall portion 2a adjacent and below the open end of the slag chute 3 and inclined relative to the axis of the chute. As shown, the lower end of the pusher member 2 is supported on the bottom of the slag receptacle for reciprocating movement therealong.

As will be understood, pusher member 2 and associated wall portion completely extend from one lateral side of receptacle 1 to the other and transversely across the bottom of the receptacle so as to prevent open communication between the slag retaining portion of the receptacle and the portion behind the pusher member.

Numeral 4 in FIG. 1 generally indicates the improved sealing means of the present invention disposed between the lower open end of slag chute 3 and the inclined upper wall portion 2a of pusher member 2, whereby the fluid in slag receptacle 1 is effectively divided into a dirty fluid portion indicated at X forwardly of the pusher member 2 and a clean fluid portion indicated at Y behind the pusher member.

With further particular reference to FIG. 2, the sealing means 4 in this instance is in the form of a flexible flap member of any known suitable resilient material. The flap-type sealing member 4 is attached by means of fastener 6 to the side wall of slag chute 3 outwardly thereof and immediately adjacent the lower end opening. Flap-type sealing member 4 is provided with a longitudinal slot 5 through which the fastener 6 extends to thereby permit vertical self adjustment of the sealing member relative to the position of the upper wall 2a of the pusher arm of pusher member 2, as indicated in broken lines in FIG. 2. Flap-type sealing member 4 is made flexible in order to accommodate the various degrees of position of the upper wall portion 2a of pusher member 2 during reciprocation of the latter. Thus, the lower end of flap-type sealing member 4 at all times remains in sealing contact upon the surface of upper wall 2a of pusher member 2, to provide an effective seal between fluid portions X and Y in receptacle 1.

As illustratively indicated in FIG. 5, the lower sealing contact surface of flap-type sealing member 4 may be provided with an interchangeable wear pad 7 of a suitable sealing material adapted to be periodically replaced in accordance with frictional wear effect during reciprocation of pusher member 2.

FIGS. 3 and 4 in the drawings are representative modifications of the present sealing means in accordance with the present invention.

In FIG. 3 the sealing means 4b is in the form of a substantially rigid flap pivotally attached to the lower end of slag chute 3. The other end of sealing member 4b in FIG. 3 is pivotally attached to an exchangeable wear pad 7 of suitable sealing material adapted for frictional sealing contact upon the surface of upper wall portion 2a of pusher member 2.

The modified sealing member in FIG. 4 comprises a flap 4c similarly pivotally attached to the lower end of slag chute 3. The lower free end of flap-type sealing member 4c has a curved end portion which is in frictional sealing contact with the upper surface of wall 2a of the pusher member, in a fashion similar to the embodiment in FIG. 2.

It will be noted that the sealing member 4, 4b or 4c of the invention permits unrestricted reciprocation of pusher member 2 while being maintained in tight sealing engagement therewith. It will be appreciated that the pressure of fluid portion X in front of and above the pusher member 2 effectively retains the pusher member 2 in contact with the bottom surface of slag receptacle 1, while maintaining sealing member 4, 4b or 4c in tight sealing engagement with the upper wall 2a of the pusher member. Thus, the pressure on the flap-type sealing member of the present invention by means of the fluid X effectively prevents any back flow of fluid from fluid portion X to fluid portion Y behind the pusher member while at the same time permitting flow of fluid from portion Y to portion X across the upper surface of upper wall 2a of the pusher member 2 and past the sealing member 4 which bridges the free space between lower end of chute 3 and the upper wall portion 2a. It will be obvious from the foregoing that sealing member 4 is subject to various modifications other than for example illustrated in FIGS. 3 and 4.

Without further analysis, the foregoing will so fully reveal the gist of the present invention that others can

by applying current knowledge readily adapt it for various applications without omitting features that, from the standpoint of prior art, fairly constitute essential characteristics of the generic or specific aspects of this invention and, therefore, such adaptations should and are intended to be comprehended within the meaning and range of equivalence of the following claims.

What is claimed as new and desired to be secured by Letters Patent is set forth in the appended

1. Slag-removal mechanism for fire boxes or the like comprising, in combination, a slag receptacle, said slag receptacle defining a fluid chamber partially filled with fluid and having a slag-disposal opening at one end thereof; a slag-dispensing chute having a lower end extending into said receptacle below the surface of said fluid; a pusher member reciprocably arranged within said receptacle for moving said slag towards said slag-disposal opening, said pusher member having an upper wall portion extending into said fluid in said receptacle for movement across said lower open end of said chute in vertically spaced relationship thereto; drive means for reciprocation of the pusher member away from and towards said slag-disposal opening; and sealing means disposed between said chute and said upper wall portion of said pusher member normally below the level of said fluid, said sealing means in conjunction with said chute and said upper wall portion dividing said fluid chamber into a dirty fluid section forwardly of said sealing means and a clean fluid section rearwardly of said sealing means in any position of said pusher member, said sealing means thus being effective to prevent entrance of dirt into said drive means irrespective of the position of said pusher member.

2. In the combination as defined in claim 1, said sealing means being automatically adjustable in response to various positions of said upper wall portion of said pusher member relative to said lower open end of said chute.

3. In the combination as defined in claim 1, said sealing means comprising a flexible flap attached at one end to the lower open end of said chute, the other end of said flap being in frictional sealing contact with said upper wall portion of said pusher member.

4. In the combination as defined in claim 3, said other end of said flexible flap sealing means being provided with an exchangeable wear pad adapted for sealing contact upon said upper wall portion of said pusher member.

5. In the combination as defined in claim 1, said sealing means comprising a substantially rigid flap, one end of said flap being pivotally attached to the lower open end of said chute and the other end of said flap being pivotally connected to a seal pad, said seal pad being in frictional sealing engagement with said upper wall portion of pusher member.

6. In the combination as defined in claim 5, said seal pad being exchangeable.

7. In the combination as defined in claim 1, said sealing means comprising a substantially rigid flap pivotally supported adjacent the lower open end of said chute, the free end of said flap being curved outwardly and in frictional sealing contact with said upper wall portion of said pusher member.

\* \* \* \* \*