

J. F. BALDWIN.

Mangle.

No. 204,701.

Patented June 11, 1878.

Fig. 1.

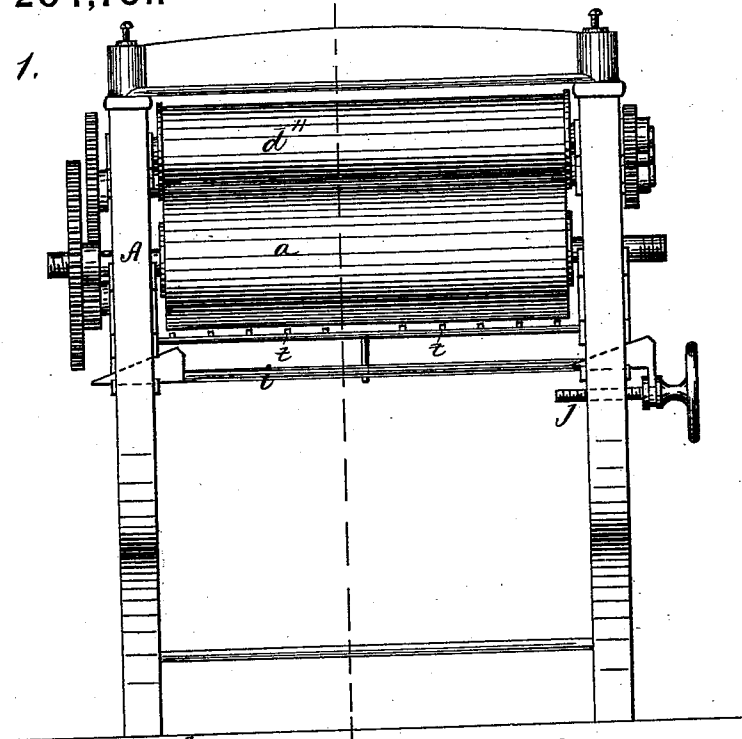

Fig. 2.

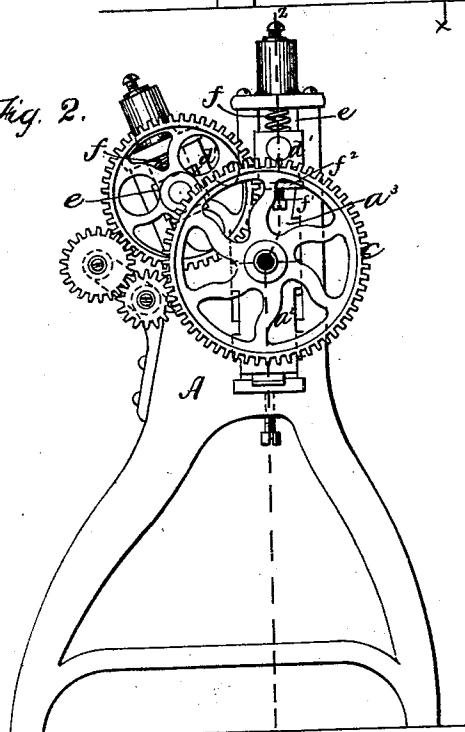
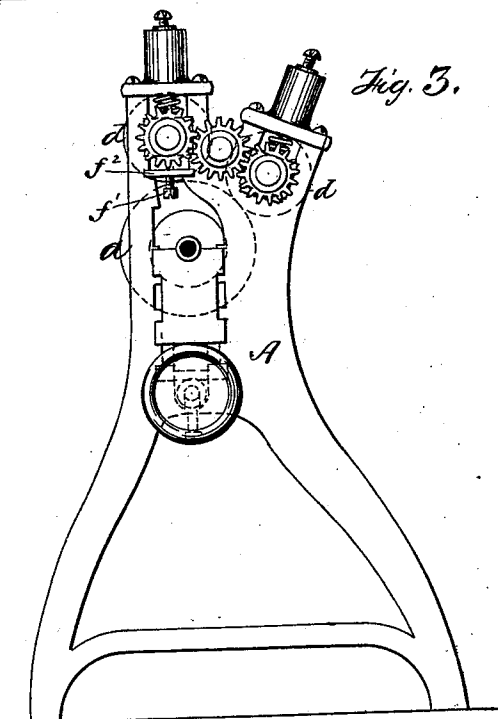

Fig. 3.



Witnesses.

L. H. H. H.
J. M. H. H.

Inventor.

J. F. Baldwin
 by *Might & Brown*
 Atty.

J. F. BALDWIN. Mangle.

No. 204,701.

Patented June 11, 1878.

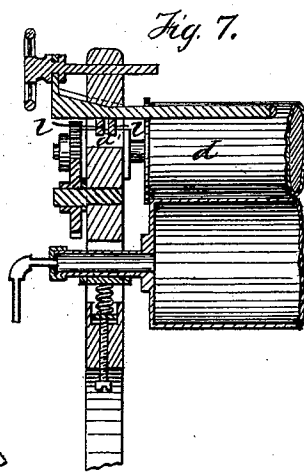
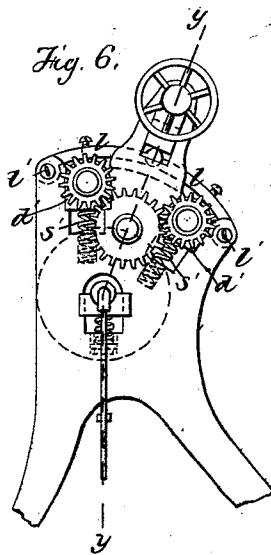
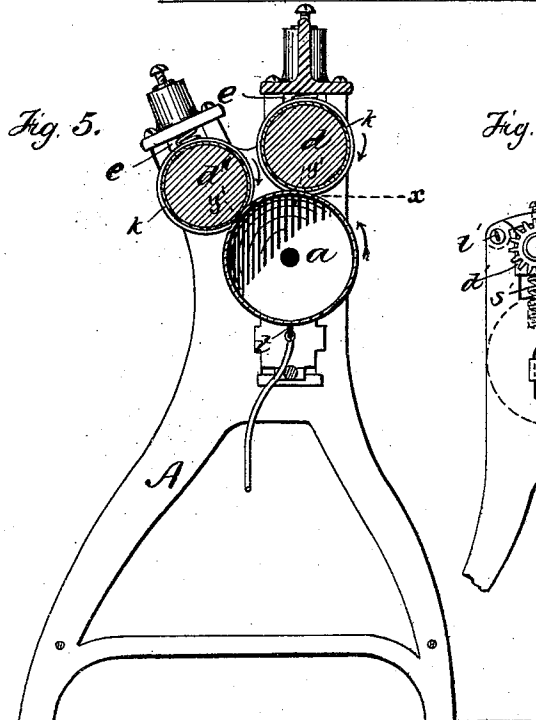
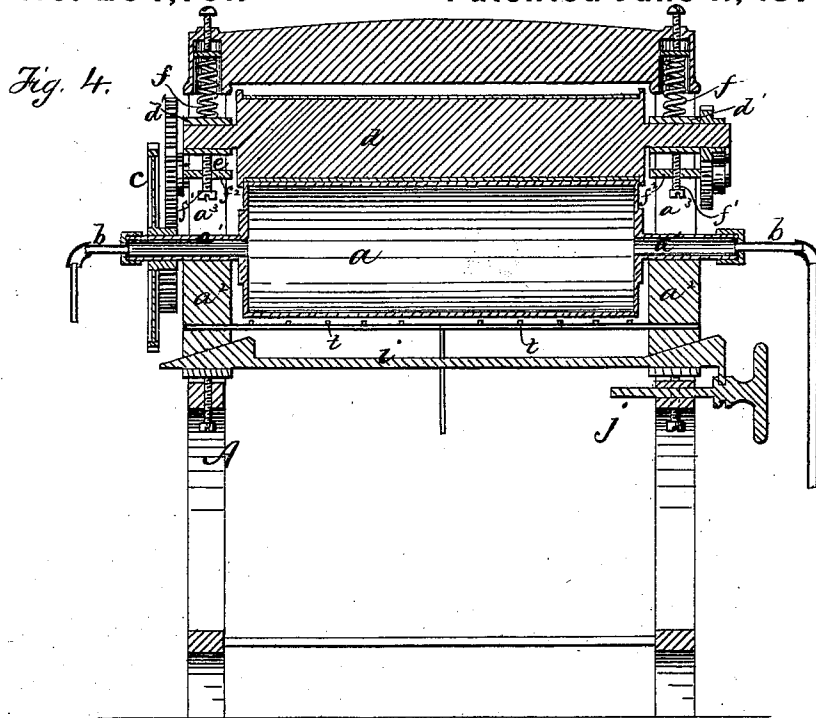

Witnesses.
G. R. Hign
J. M. Hign

Inventor.
J. F. Baldwin
by *Night & Brown*
Atty.

UNITED STATES PATENT OFFICE.

JOSEPH F. BALDWIN, OF CHELSEA, MASSACHUSETTS.

IMPROVEMENT IN MANGLES.

Specification forming part of Letters Patent No. **204,701**, dated June 11, 1878; application filed May 16, 1878.

To all whom it may concern:

Be it known that I, JOSEPH F. BALDWIN, of Chelsea, in the county of Suffolk and State of Massachusetts, have invented certain Improvements in Mangles, of which the following is a specification:

The first part of my invention relates to the mode of ironing by means of a heated cylinder and elastic-faced rollers arranged to obtain a greatly-increased ironing-face, permits the free escape of the steam, and maintains a constant pressure on all parts of articles of varying thickness without crushing the thicker portions.

The second part of my invention relates to mangles, in which a rigid main roll is combined with one or more pressure-rolls having compressible surfaces, and pressed by springs toward the main roll; and it has for its object to enable the pressure-rolls to be so adjusted with reference to the main roll that when thin delicate fabrics are passed between the rolls the pressure applied will be wholly produced by the compression of the surfaces of the pressure-rolls, without the co-operation of the springs, so far as the pressing operation is concerned, while in pressing thicker fabrics or thicker portions of the same article the springs will enable the pressure-rolls to be displaced sufficiently to enable such thicker articles to pass under increased pressure between the rolls.

The third part of my invention relates to steam-heated rolls for mangles; and has for its object to provide means for externally heating a mangle-roll, which is adapted to be internally heated by steam, thereby preventing condensation of steam in such roll.

To these ends my invention consists in the provision of means for simultaneously varying the degree of pressure between the main roll and all of the pressure-rolls, for regulating or limiting the approach of the pressure-rolls to the main roll, and for heating the exterior of a steam-heated roll, all of which I will now proceed to describe and claim.

Of the accompanying drawings, forming a part of this specification, Figure 1 represents a front elevation of a mangle embodying my improvements. Figs. 2 and 3 represent end

elevations of the same. Fig. 4 represents a section on line *z z*, Fig. 2. Fig. 5 represents a section on line *x x*, Fig. 1. Fig. 6 represents a modification of the means for the simultaneous adjustment of the pressure between the main roll and all of the pressure-rolls; and Fig. 7 represents a section on line *y y*, Fig. 6. Similar letters refer to like parts in all the figures.

Ironing-machines constructed in the ordinary manner are open to serious objections. The "French" ironer in common use is very slow in its operation, and but little pressure can be applied, owing to the extended ironing-surface, which is stationary, creating so much friction with high pressure as to seriously impede the feed. This friction will also wrinkle the cloth, especially when folded to form several thicknesses.

Another form of mangle consists of a pair of rolls, one heated and the other with a cloth surface.

In some instances two or more pairs are used, (sometimes with hard rolls,) connected by a feeding device—as, for instance, an endless cloth or band extending from one pair to the other, either over the rolls or between them.

There is one great objection to all ironers in which rolls have been used, to wit: the point of contact between the polishing and elastic feed or pressure roll is only a single line of such limited width that practically little ironing-surface is obtained, and the machine, in effect, is simply a heated mangle. The use of several pairs of rolls only duplicates this effect, with much increase of expense and little advantage.

It has been proposed to carry the articles between a heated cylinder and a series of rolls by means of an endless band traversing such rolls; but the effect of the use of elastic-faced rolls is lost, while the application of pressure causes the band to wrinkle or fold between the rolls irregularly, running to one side or the other.

In no case can ironing be practically performed between hard rolls, as most articles to be ironed have seams, or are of unequal thickness, and the rolls only rest on the seams, or

else crush the latter, if pressure sufficient to bring the rolls in contact with the general surface is applied.

By the use of an elastic pressure-roll with a heated polishing-roll the whole surface of the article is pressed upon, but without destructive action. Two or more heated rolls have been used with a single carrying-roll; but here there are only two narrow lines of heat and pressure, affording no advantage over a single pair of rolls when used twice or more upon the same article.

The object of my invention is to combine the advantages of the heated polishing and soft pressure-rolls and the extended ironing-surface obtained by the use of the French machine without the disadvantages of the latter, and with greatly improved results over either. This I effect by the use of a single heated polishing-roll, *a*, and two or more elastic-surface pressure-rolls, *d d''*, arranged substantially as shown in the drawing.

The rolls are geared to turn together, as hereinafter described, and the article introduced on the line *x*, Fig. 5, being first carried between the rolls *a d* with the same effect as when a single pair of rolls is employed, is then carried between the rolls *a d''* with a like effect. It is also stretched between the two points of contact, *y y*, across the face of the heated cylinder *a* between said points, which operates not only as a continuous ironing-surface between the two lines *y y*, but further heats the article while permitting a free vent for the vapors which escape, so that while the article is mangled, as it were, between the rolls *a d*, it is then dried, and then polished while heated, and without opportunity to cool, between the rolls *a d''*, and issues from the machine in a polished, highly-finished state, and, what is of equal importance, it is dry and ready for use, as otherwise it would require a subsequent operation.

It will be seen that this is effected without any of the disadvantages attendant on the use of carrying-bands; that the heat is continued along the whole distance between the points *y y*; and that the heating, pressure, and polishing effects are obtained without any crushing of the thickened parts of the article, and with a direct uniform pressure on the whole surface thereof.

I will now describe the construction of the apparatus in which I embody the cylinder and rolls to operate as above set forth.

In the drawings, *A* represents the general supporting-frame of the parts to be described. *a* represents the main roll, which is adapted to be heated, preferably by steam, and is made hollow and provided with hollow arbors *a¹ a¹* and pipes *b b* for the admission and escape of steam.

The roll is of metal, and is highly polished on its periphery. *c* represents a cog-wheel on one of the arbors of the roll *a*, by which the latter is positively rotated in the direction indicated by the arrow in Fig. 5, the wheel *c* being driven by any suitable prime motor.

The arbors of the roll *a* are supported in boxes *a²*, arranged to slide in vertical guides *a³* in frame *A*.

d d'' represent the pressure-rolls, which are two or more in number, and are arranged to bear against the periphery of the roll *a* along the entire length of the latter, all the rolls being parallel.

The rolls *d d''* are preferably of metal, provided with suitable yielding or flexible coverings *k*, composed preferably of felting, covered with cotton cloth. This kind of covering is yielding or compressible under pressure, expands readily after the removal of the compressing-pressure, and does not become compacted or hardened by continued or repeated dry pressure.

The rolls *d* are held with a yielding pressure against the roll *a*, and their arbors are located in boxes *d'*, which are adapted to slide in guides *e e* in frame *A*, which guides are approximately radial to the axis of the roll *a*.

f f represent springs, which press the boxes *d'* toward the roll *a*.

The rolls *d d''* are positively rotated in a direction opposite to the direction of rotation of the roll *a*, as indicated by arrows in Fig. 5, and are driven by any suitable system or arrangement of gearing. I prefer to employ the arrangement shown in Figs. 2 and 3.

For simultaneously adjusting or regulating the degree of pressure between the roll *a* and all of the pressure-rolls *d d''*, I prefer to employ a wedge-bar, *i*, arranged under the boxes *a²*, as shown in Figs. 1 and 4, and adapted, when moved lengthwise, to raise or lower said boxes, according to the direction in which it is moved. I prefer to move the bar *i* by a screw, *j*, working in a socket in the frame *A*.

When the roll *a* is raised by the wedge-bar the rolls *d d''* are caused to move outwardly in their radial guides *e e*, and thus compress the springs *f*, thereby increasing the pressure of the latter. The radial arrangement of the guide *e* enables the roll *a* to displace or move the rolls *d* outwardly, with less resistance and with less increase of distance between the respective points of contact of the rolls *d* with the roll *a* than if the guides *e* were parallel.

If desired, the roll *a* may be in fixed bearings, and the wedge-bar may be arranged to press down on levers *l l*, pivoted to the frame *A* at *l' l'*, and bearing on the boxes of the rolls *a d*, as shown in Figs. 6 and 7. In this modification the wedge-bar is depressed when moved endwise in one direction, and depresses the rolls *d d* simultaneously through the levers *l l*, which swing downwardly on their pivots. The boxes of the rolls *d d* are supported by springs *s' s'* against the pressure of the levers *l l*.

f¹ f¹ represent adjustable stops, which are arranged to limit the movement of the boxes *d'* and rolls *d* toward the roll *a*, but not away from the latter. These stops are preferably in the form of screws, working in threaded sockets in plates *f²*, rigidly attached to the

frame A. By elevating said screws they can be caused to support the rolls *d* so that the latter will barely touch or be entirely separated from the roll *a*, while by lowering said screws their support can be entirely withdrawn from the rolls *d*, so that the latter will be pressed with the full force of the springs *f* against the roll *a*. This provision enables the rolls *d* to be adjusted with reference to the roll *a*, so that they will barely touch the latter or be entirely separated therefrom. By so adjusting the rolls *d* that the only pressure which they exert on the roll *a* is due to the compression of the compressible coverings *k*, very delicate fabrics, such as laces, &c., can be passed between the rolls without receiving any injurious pressure.

It will be seen that when the rolls are adjusted to produce the result last described, the stops support the rolls *d* in such positions that the coverings *k* of the rolls are somewhat compressed along their line of contact with the roll, the springs holding the boxes of the rolls *d* down upon the stops, and the latter sustaining the greater part of the pressure of the springs, instead of allowing the rolls *d* to be pressed with the full force of the springs against the roll *a*.

It must be borne in mind, however, that the stops *f*¹ do not interfere with the movement of the rolls *d* away from roll *a*. Under the described conditions, if a thin delicate fabric be passed between the rolls *d* *a*, the only pressure exerted on it will be caused by the compression of the coverings of rolls *d*; hence the fabric will receive no injurious or crushing pressure, while the described adaptability of the rolls to yield will allow thicker fabrics or thicker portions of the same article to pass between the rolls under an increased pressure. The mangle is thus rendered self-adjusting to a certain extent, the pressure varying with the thickness of the article.

t t represent a series of gas-burners, arranged under the roll *a*, as shown in Figs. 1, 4, and 5. These burners are for the purpose of heating or warming the roll *a*, and thus preventing the steam from condensing therein.

I am aware that gas-burners have been em-

ployed to internally heat mangle or ironing-machine rolls; but I am not aware that they have been arranged in connection with a steam-heated roll, as above described. The burners should be of the kind known as "Bunsen burners," so that the combustion of gas will not soil or smut the surface of the roll *a*.

I claim as my invention—

1. The within-described improvement in ironing, consisting in subjecting the articles to the action of a heated cylinder and elastic-faced rolls, which bear upon the cylinder on parallel lines *y y*, and retain the articles as they pass between said lines in contact with the intermediate heated ironing-face, substantially as set forth.

2. The combination of the heated cylinder *a* and elastic-faced rolls *d d'*, having parallel points of contact with the cylinder, and operating to stretch the goods over the ironing-surface between said points, as set forth.

3. The combination of the heated cylinder *c*, having adjustable bearings, and the elastic-faced rolls *d d'*, turning in yielding bearings adjustable radially, substantially as specified.

4. In a mangle, the combination of the roll *a*, having a rigid surface, the roll or rolls *d*; having compressible coverings *k*, and the springs *f*, for pressing the roll or rolls *d* toward the roll *a*, with the adjustable stops *f*¹, for rigidly supporting the roll or rolls *d* against the pressure of the springs *f* without interfering with the yielding of the latter, thereby enabling the rolls *d* to be adjusted so that the yielding pressure on thin fabrics will be produced by the compression of the coverings *k*, the springs *f* permitting the passage of thicker articles under an increased pressure, as set forth.

5. In a mangle, the combination, with the steam-heated roll *a*, of a series of external gas-burners, as specified.

In testimony whereof I have signed my name to this specification in the presence of two subscribing witnesses.

JOSEPH F. BALDWIN.

Witnesses:

H. G. THOMAS,
C. F. BROWN.