

(19) World Intellectual Property Organization
International Bureau



(43) International Publication Date
27 April 2006 (27.04.2006)

PCT

(10) International Publication Number
WO 2006/045094 A2

(51) International Patent Classification:
A61B 17/70 (2006.01) A61F 2/44 (2006.01)

(72) Inventor; and

(75) Inventor/Applicant (for US only): KIM, Daniel H. [US/US]; 411 Los Ninos Way, Los Altos, California 94022 (US).

(21) International Application Number:
PCT/US2005/038026

(74) Agent: LASALLE, Carol M.; Bozicevic, Field & Francis Llp, 1900 University Avenue, Suite 200, East Palo Alto, California 94303 (US).

(22) International Filing Date: 20 October 2005 (20.10.2005)

(25) Filing Language: English

(81) Designated States (unless otherwise indicated, for every kind of national protection available): AE, AG, AL, AM, AT, AU, AZ, BA, BB, BG, BR, BW, BY, BZ, CA, CH, CN, CO, CR, CU, CZ, DE, DK, DM, DZ, EC, EE, EG, ES, FI, GB, GD, GE, GH, GM, HR, HU, ID, IL, IN, IS, JP, KE, KG, KM, KP, KR, KZ, LC, LK, LR, LS, LT, LU, LV, LY, MA, MD, MG, MK, MN, MW, MX, MZ, NA, NG, NI, NO, NZ, OM, PG, PH, PL, PT, RO, RU, SC, SD, SE, SG, SK, SL, SM, SY, TJ, TM, TN, TR, TT, TZ, UA, UG, US, UZ, VC, VN, YU, ZA, ZM, ZW.

(26) Publication Language: English

(30) Priority Data:
10/970,843 20 October 2004 (20.10.2004) US
11/006,502 6 December 2004 (06.12.2004) US
11/052,002 4 February 2005 (04.02.2005) US
11/079,006 10 March 2005 (10.03.2005) US
11/190,496 26 July 2005 (26.07.2005) US

(71) Applicant (for all designated States except US): THE BOARD OF TRUSTEES OF THE LELAND STANFORD JUNIOR UNIVERSITY [US/US]; 1705 El Camino Real, Palo Alto, California 94306-1106 (US).

(84) Designated States (unless otherwise indicated, for every kind of regional protection available): ARIPO (BW, GH, GM, KE, LS, MW, MZ, NA, SD, SL, SZ, TZ, UG, ZM, ZW), Eurasian (AM, AZ, BY, KG, KZ, MD, RU, TJ, TM),

[Continued on next page]

(54) Title: SYSTEMS AND METHODS FOR POSTERIOR DYNAMIC STABILIZATION OF THE SPINE

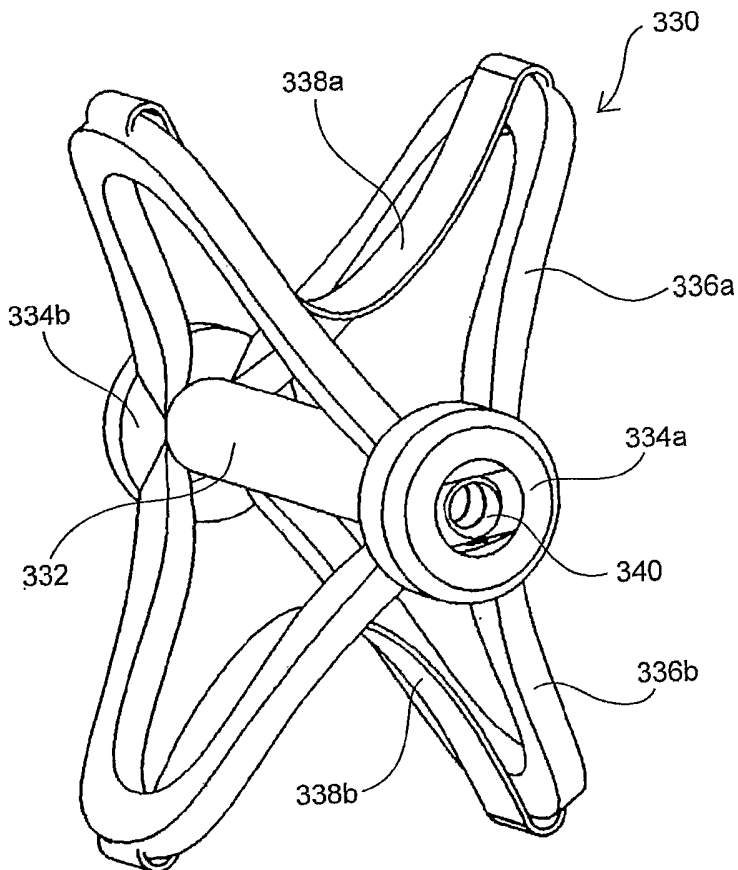

(57) Abstract: Devices, systems and methods for dynamically stabilizing the spine are provided. The devices include an expandable spacer having an undeployed configuration and a deployed configuration, wherein the spacer has axial and radial dimensions for positioning between the spinous processes of adjacent vertebrae. The systems include one or more spacers and a mechanical actuation means for delivering and deploying the spacer. The methods involve the implantation of one or more spacers within the interspinous space.

WO 2006/045094 A2



European (AT, BE, BG, CH, CY, CZ, DE, DK, EE, ES, FI, FR, GB, GR, HU, IE, IS, IT, LT, LU, LV, MC, NL, PL, PT, RO, SE, SI, SK, TR), OAPI (BF, BJ, CF, CG, CI, CM, GA, GN, GQ, GW, ML, MR, NE, SN, TD, TG).

For two-letter codes and other abbreviations, refer to the "Guidance Notes on Codes and Abbreviations" appearing at the beginning of each regular issue of the PCT Gazette.

Published:

- *without international search report and to be republished upon receipt of that report*

SYSTEMS AND METHODS FOR POSTERIOR DYNAMIC STABILIZATION OF THE SPINE**Cross-Reference to Related Applications**

[0001] This application claims priority to U.S. Patent Application No. 11/190,496, filed July 26, 2005, which is a continuation-in-part of U.S. Patent Application Serial No. 11/079,006, filed on March 10, 2005, which is a continuation-in-part of U.S. Patent Application Serial No. 11/052,002, filed on February 4, 2005, which is a continuation-in-part of U.S. Patent Application Serial No. 11/006,502, filed on December 6, 2004, which is a continuation-in-part of U.S. Patent Application Serial No. 10/970,843, filed on October 20, 2004, incorporated herein by reference in their entireties.

Field of the Invention

[0002] The present invention is directed towards the treatment of spinal disorders and pain. More particularly, the present invention is directed to systems and methods of treating the spine, which eliminate pain and enable spinal motion, which effectively mimics that of a normally functioning spine.

Background of the Invention

[0003] Fig. 1 illustrates a portion of the human spine having a superior vertebra 2 and an inferior vertebra 4, with an intervertebral disc 6 located in between the two vertebral bodies. The superior vertebra 2 has superior facet joints 8a and 8b, inferior facet joints 10a and 10b, and spinous process 18. Pedicles 3a and 3b interconnect the respective superior facet joints 8a, 8b to the vertebral body 2. Extending laterally from superior facet joints 8a, 8b are transverse processes 7a and 7b, respectively. Extending between each inferior facet joints 10a and 10b and the spinous process 18 are laminal zones 5a and 5b, respectively. Similarly, inferior vertebra 4 has superior facet joints 12a and 12b, superior pedicles 9a and 9b, transverse processes 11a and 11b, inferior facet joints 14a and 14b, laminal zones 15a and 15b, and spinous process 22.

[0004] The superior vertebra with its inferior facets, the inferior vertebra with its superior facet joints, the intervertebral disc, and seven spinal ligaments (not shown) extending between the superior and inferior vertebrae together comprise a spinal motion segment or functional spine unit. Each spinal motion segment enables motion along three orthogonal axes, both in rotation and in translation. The various spinal motions are illustrated in Figs. 2A-2C. In particular, Fig. 2A illustrates flexion and extension motions and axial loading, Fig. 2B illustrates lateral

bending motion and Fig. 2C illustrated axial rotational motion. A normally functioning spinal motion segment provides physiological limits and stiffness in each rotational and translational direction to create a stable and strong column structure to support physiological loads.

[0005] Traumatic, inflammatory, metabolic, synovial, neoplastic and degenerative disorders of the spine can produce debilitating pain that can affect a spinal motion segment's ability to properly function. The specific location or source of spinal pain is most often an affected intervertebral disc or facet joint. Often, a disorder in one location or spinal component can lead to eventual deterioration or disorder, and ultimately, pain in the other.

[0006] Spine fusion (arthrodesis) is a procedure in which two or more adjacent vertebral bodies are fused together. It is one of the most common approaches to alleviating various types of spinal pain, particularly pain associated with one or more affected intervertebral discs. While spine fusion generally helps to eliminate certain types of pain, it has been shown to decrease function by limiting the range of motion for patients in flexion, extension, rotation and lateral bending. Furthermore, the fusion creates increased stresses on adjacent non-fused motion segments and accelerated degeneration of the motion segments. Additionally, pseudarthrosis (resulting from an incomplete or ineffective fusion) may not provide the expected pain-relief for the patient. Also, the device(s) used for fusion, whether artificial or biological, may migrate out of the fusion site creating significant new problems for the patient.

[0007] Various technologies and approaches have been developed to treat spinal pain without fusion in order to maintain or recreate the natural biomechanics of the spine. To this end, significant efforts are being made in the use of implantable artificial intervertebral discs. Artificial discs are intended to restore articulation between vertebral bodies so as to recreate the full range of motion normally allowed by the elastic properties of the natural disc. Unfortunately, the currently available artificial discs do not adequately address all of the mechanics of motion for the spinal column.

[0008] It has been found that the facet joints can also be a significant source of spinal disorders and debilitating pain. For example, a patient may suffer from arthritic facet joints, severe facet joint tropism, otherwise deformed facet joints, facet joint injuries, etc. These disorders lead to spinal stenosis, degenerative spondylolithesis, and/or isthmic spondylolisthesis, pinching the nerves that extend between the affected vertebrae.

[0009] Current interventions for the treatment of facet joint disorders have not been found to provide completely successful results. Facetectomy (removal of the facet joints) may provide some pain relief; but as the facet joints help to support axial, torsional, and shear loads that act

on the spinal column in addition to providing a sliding articulation and mechanism for load transmission, their removal inhibits natural spinal function. Laminectomy (removal of the lamina, including the spinal arch and the spinous process) may also provide pain relief associated with facet joint disorders; however, the spine is made less stable and subject to hypermobility. Problems with the facet joints can also complicate treatments associated with other portions of the spine. In fact, contraindications for disc replacement include arthritic facet joints, absent facet joints, severe facet joint tropism, or otherwise deformed facet joints due to the inability of the artificial disc (when used with compromised or missing facet joints) to properly restore the natural biomechanics of the spinal motion segment.

[0010] While various attempts have been made at facet joint replacement, they have been inadequate. This is due to the fact that prosthetic facet joints preserve existing bony structures and therefore do not address pathologies that affect facet joints themselves. Certain facet joint prostheses, such as those disclosed in U.S. Pat. No. 6,132,464, are intended to be supported on the lamina or the posterior arch. As the lamina is a very complex and highly variable anatomical structure, it is very difficult to design a prosthesis that provides reproducible positioning against the lamina to correctly locate the prosthetic facet joints. In addition, when facet joint replacement involves complete removal and replacement of the natural facet joint, as disclosed in U.S. Patent No. 6,579,319, the prosthesis is unlikely to endure the loads and cycling experienced by the vertebra. Thus, the facet joint replacement may be subject to long-term displacement. Furthermore, when facet joint disorders are accompanied by disease or trauma to other structures of a vertebra (such as the lamina, spinous process, and/or transverse processes) facet joint replacement is insufficient to treat the problem(s).

[0011] Most recently, surgical-based technologies, referred to as “dynamic posterior stabilization,” have been developed to address spinal pain resulting from more than one disorder, when more than one structure of the spine have been compromised. An objective of such technologies is to provide the support of fusion-based implants while maximizing the natural biomechanics of the spine. Dynamic posterior stabilization systems typically fall into one of two general categories: posterior pedicle screw-based systems and interspinous spacers.

[0012] Examples of pedicle screw-based systems are disclosed in U.S. Patent Nos. 5,015,247, 5,484,437, 5,489,308, 5,609,636 and 5,658,337, 5,741,253, 6,080,155, 6,096,038, 6,264,656 and 6,270,498. These types of systems involve the use of screws that are positioned in the vertebral body through the pedicle. Certain types of these pedicle screw-based systems may be used to augment compromised facet joints, while others require removal of the spinous process

and/or the facet joints for implantation. One such system, the Zimmer Spine Dynesys® employs a cord which is extended between the pedicle screws and a fairly rigid spacer which is passed over the cord and positioned between the screws. While this system is able to provide load sharing and restoration of disc height, because it is so rigid, it does not effectively preserve the natural motion of the spinal segment into which it is implanted. Other pedicle screw-based systems employ articulating joints between the pedicle screws. Because these types of systems require the use of pedicle screws, implantation of the systems are often more invasive to implant than interspinous spacers.

[0013] Where the level of disability or pain to the affected spinal motion segments is not that severe or where the condition, such as an injury, is not chronic, the use of interspinous spacers are preferred over pedicle based systems as they require a less invasive implantation approach and less dissection of the surrounding tissue and ligaments. Examples of interspinous spacers are disclosed in U.S. Patent Nos. Re. 36,211, 5,645,599, 6,149,642, 6,500,178, 6,695,842, 6,716,245 and 6,761,720. The spacers, which are made of either a hard or compliant material, are placed in between adjacent spinous processes. The harder material spacers are fixed in place by means of the opposing force caused by distracting the affected spinal segment and/or by use of keels or screws that anchor into the spinous process. While slightly less invasive than the procedures required for implanting a pedicle screw-based dynamic stabilization system, implantation of hard or solid interspinous spacers still requires dissection of muscle tissue and of the supraspinous and interspinous ligaments. Additionally, these tend to facilitate spinal motion that is less analogous to the natural spinal motion than do the more compliant and flexible interspinous spacers. Another advantage of the compliant/flexible interspinous spacers is the ability to deliver them somewhat less invasively than those that are not compliant or flexible; however, their compliancy makes them more susceptible to displacement or migration over time. To obviate this risk, many of these spacers employ straps or the like that are wrapped around the spinous processes of the vertebrae above and below the level where the spacer is implanted. Of course, this requires some additional tissue and ligament dissection superior and inferior to the implant site, i.e., at least within the adjacent interspinous spaces.

[0014] With the limitations of current spine stabilization technologies, there is clearly a need for an improved means and method for dynamic posterior stabilization of the spine that address the drawbacks of prior devices. In particular, it would be highly beneficial to have a dynamic stabilization system that involves a minimally invasive implantation procedure, where the extent of distraction between the affected vertebrae is adjustable upon implantation and at a

later time if necessary. It would be additionally advantageous if the system or device was also removable in a minimally invasive manner.

Summary of the Invention

- [0015] The present invention provides devices, systems and methods for stabilizing at least one spinal motion segment. The stabilizing devices include an expandable spacer or member having an unexpanded configuration and an expanded configuration, wherein the expandable member in an expanded configuration has a size, volume, diameter, length, cross-section and/or shape configured for positioning between the spinous processes of adjacent vertebrae in order to distract the vertebrae relative to each other.
- [0016] In certain embodiments, the expandable member is a balloon made of either non-compliant or compliant material which may be porous or non-porous, or may include a mesh material which may be coated or lined with a porous or non-porous material. The material may define a cavity which is fillable with an inflation and/or expansion medium for inflating and/or expanding the expandable member. The device may further include a port for coupling to a source of inflation/expansion medium. In certain embodiments, the port may be used to deflate or evacuate the expandable member.
- [0017] In other embodiments, the expandable members are cages, struts, wires or solid objects having a first or unexpanded shape (having a lower profile) which facilitates delivery to the implant site and a second or expanded shape (having a larger profile) which facilitates distraction between vertebrae. The devices may have annular, spherical, cylindrical, cross, "X", star or elliptical shapes when in an expanded condition and/or unexpanded condition. The expandable members may be self-expanding or adjustably expandable depending on the extent of distraction required.
- [0018] The stabilizing devices may be configured such that the transformation from the low-profile state to the high-profile state is immediate or gradual, where the extent of expansion is controllable. The transformation may occur in one-step or evolve in continuous fashion where at least one of volume, shape, size, diameter, length, etc. is continually changing until the desired expansion end point is achieved. This transformation may be reversible such that after implantation, the stabilizing device may be partially or completely unexpanded, collapsed, deflated or at least reduced in size, volume, etc. in order to facilitate removal of the member from the implant site or to facilitate adjustment or repositioning of the member in vivo.
- [0019] The stabilizing devices may be configured to stay stationary in the implant site on their own (or "float") or may be further fixed or anchored to surrounding tissue, e.g., bone (e.g.,

spinous processes, vertebrae), muscle, ligaments or other soft tissue, to ensure against migration of the implant. In their final deployed state, the stabilizing devices may be flexible to allow some degree of extension of the spine or may otherwise be rigid so as prevent extension altogether. Optionally, the devices may include one or more markers on a surface of the expandable member to facilitate fluoroscopic imaging.

[0020] The invention further includes systems for stabilizing at least one spinal motion segment which include one or more of the expandable members as described above. For spacers having a balloon configuration, the systems may further include an expansion medium for injection within or for filling the interior of the expandable member via the port. For expandable members which are expandable by mechanical means or actuation, the systems may further include delivery mechanisms to which the stabilizing spacers are attached which, when actuated or released from the stabilizing device, cause the device to expand. The subject systems may further include at least one means for anchoring or securing the expandable member to the spinal motion segment.

[0021] The invention further includes methods for stabilizing at least one spinal motion segment which involve the implantation of one or more devices or expandable spacers of the present invention, in which the expandable member is positioned between the spinous processes of adjacent vertebrae in an unexpanded or undeployed condition and then subsequently expanded or deployed to a size and/or shape for selectively distracting the adjacent vertebrae. The invention also contemplates the temporary implantation of the subject devices which may be subsequently removed from the patient once the intended treatment is complete. The methods may also include adjustment of the implants in vivo.

[0022] Many of the methods involve the percutaneous implantation of the subject devices from either an ipsilateral approach or a mid-line approach into the interspinous space. Certain methods involve the delivery of certain components by a lateral approach and other components by a mid-line approach. The implantation methods may involve the use of cannulas through which the stabilizing devices are delivered into an implant site, however, such may not be required, with the stabilizing devices be configured to pass directly through an incision.

[0023] These and other objects, advantages, and features of the invention will become apparent to those persons skilled in the art upon reading the details of the invention as more fully described below.

Brief Description of the Drawings

- [0024] The invention is best understood from the following detailed description when read in conjunction with the accompanying drawings. It is emphasized that, according to common practice, the various features of the drawings are not to-scale. On the contrary, the dimensions of the various features are arbitrarily expanded or reduced for clarity. Included in the drawings are the following figures:
- [0025] Fig. 1 illustrates a perspective view of a portion of the human spine having two vertebral segments.
- [0026] Figs. 2A, 2B and 2C illustrate left side, dorsal and top views, respectively, of the spinal segments of Fig. 1A under going various motions.
- [0027] Fig. 3A illustrates an interspinous device of the present invention in an unexpanded or collapsed state coupled to a cannula of the delivery system of the present invention. Fig. 3B is an enlarged view of the interspinous device of Fig. 3A.
- [0028] Fig. 4A illustrates an interspinous device of the present invention in an expanded state coupled to a cannula of the delivery system of the present invention. Fig. 4B is an enlarged view of the interspinous device of Fig. 4A.
- [0029] Figs. 5A-5C illustrate top, dorsal and side views of an initial step of the method of the present invention in which a cannula is delivered to the target implant site.
- [0030] Figs. 6A and 6B illustrate dorsal and side views of the step of dissecting an opening within the spinous ligament utilizing a cutting instrument of the system of Figs. 3 and 4. Fig. 6C is an enlarged view of the target area within the spinous ligament.
- [0031] Figs. 7A and 7B illustrate dorsal and side views of the step of inserting the interspinous device of Fig. 4A into the dissected opening of the spinous ligament. Figs. 7C and 7D are enlarged views of the target area in Figs. 7A and 7B, respectively.
- [0032] Figs. 8A and 8B illustrate dorsal and side views of the step of inflating or expanding the interspinous device of Fig. 4A within the implant site. Figs. 8C and 8D are enlarged views of the target area in Figs. 8C and 8D, respectively.
- [0033] Fig. 9A illustrates a side view of the step of filling the interspinous device of Fig. 4A with an expansion medium. Fig. 9B is an enlarged view of the target area in Fig. 9A.
- [0034] Fig. 10A illustrates a dorsal view of the step of further securing the interspinous device of Fig. 4A within the implant site. Fig. 10B is an enlarged view of the target area in Fig. 10A.

- [0035] Figs. 11A and 11B illustrate dorsal aid side views of the step of inserting another embodiment of an interspinous device into the dissected opening of the spinous ligament. Figs. 11C and 11D are enlarged views of the target area in Figs. 11A and 11B, respectively.
- [0036] Figs. 12A and 12B illustrate dorsal aid side views of the step of expanding the interspinous device of Figs. 11A-11D within the implant site. Figs. 12C and 12D are enlarged views of the target area in Figs. 12A and 12B, respectively.
- [0037] Fig. 13A illustrates a side view of the step of filling the interspinous device of Figs. 11A-11D with an expansion medium. Fig. 13B is an enlarged view of the target area in Fig. 13A.
- [0038] Figs. 14A-14F illustrate dorsal views of another interspinous device of the present invention and a device for implanting the interspinous device where the implantation device is used initially distract the interspinous space prior to implanting the interspinous device.
- [0039] Figs. 15A and 15B illustrate dorsal views of another interspinous device of the present invention implanted within an interspinous space.
- [0040] Figs. 16A and 16B illustrate dorsal views of another interspinous device of the present invention implanted within an interspinous space. Fig. 16C is a side view of Fig. 16B.
- [0041] Figs. 17A and 17B illustrate side views of another interspinous device of the present invention implanted within an interspinous space. Fig. 17C is a dorsal view of Fig. 17B.
- [0042] Figs. 18A and 18B illustrate another interspinous device of the present invention in undeployed and deployed states, respectively.
- [0043] Figs. 19A and 19B illustrate the device of Fig. 18 implanted within an interspinous space and operably coupled to a delivery device of the present invention.
- [0044] Figs. 20A and 20B illustrate cut-away views of two embodiments of the handle portion of the delivery device of Figs. 19A and 19B.
- [0045] Fig. 21 illustrates a cut-away view of a distal portion of the device of Fig. 18 operably positioned over the delivery device of Fig. 20B.
- [0046] Figs. 22A-22C illustrate another interspinous spacer device of the present invention in undeployed, partially deployed and fully deployed states, respectively.
- [0047] Figs. 23A-23C illustrate another interspinous spacer device of the present invention in undeployed, partially deployed and fully deployed states, respectively.
- [0048] Figs. 24A-24C illustrate yet another interspinous spacer device of the present invention in undeployed, partially deployed and fully deployed states, respectively.

- [0049] Figs. 25A-25C illustrate another interspinous spacer device of the present invention in undeployed, partially deployed and fully deployed states, respectively.
- [0050] Figs. 26A and 26B illustrate perspective and front views of another interspinous spacer device of the present invention in a deployed state.
- [0051] Fig. 27 illustrates a front view of another interspinous spacer device of the present invention.
- [0052] Fig. 28A illustrates a step in a method of implanting the interspinous spacer device of Figs. 26A and 26B. Figs. 28A' and 28A'' illustrate side and front views of the interspinous spacer device in an undeployed state in the context of the step illustrated in Fig. 28A.
- [0053] Fig. 28B illustrates a step in a method of implanting the interspinous spacer device of Figs. 26A and 26B. Figs. 28B' and 28B'' illustrate side and front views of the interspinous spacer device in a partially deployed state in the context of the step illustrated in Fig. 28B.
- [0054] Fig. 28C illustrates a step in a method of implanting the interspinous spacer device of Figs. 26A and 26B. Figs. 28C' and 28C'' illustrate side and front views of the interspinous spacer device in a partially deployed state in the context of the step illustrated in Fig. 28C.
- [0055] Fig. 28D illustrates a step in a method of implanting the interspinous spacer device of Figs. 26A and 26B in which the spacer is fully deployed and being released from a delivery device.
- [0056] Fig. 28E illustrates the interspinous spacer device of Figs. 26A and 26B operatively implanted within an interspinous space.
- [0057] Fig. 29A and 29A' illustrate perspective and front views of another interspinous spacer device of the present invention in an undeployed state.
- [0058] Fig. 29B and 29B' illustrate perspective and front views of the interspinous spacer device of Fig. 29A in a partially deployed state.
- [0059] Fig. 29C and 29C' illustrate perspective and front views of the interspinous spacer device of Fig. 29A in a partially deployed state but one which is more deployed than depicted in Fig. 29B.
- [0060] Fig. 29D and 29D' illustrate perspective and front views of the interspinous spacer device of Fig. 29A in a fully deployed state.
- [0061] Fig. 30A and 30A' illustrate perspective and front views of another interspinous spacer device of the present invention in a fully deployed state.
- [0062] Fig. 30B and 30B' illustrate perspective and side views of the interspinous spacer device of Fig. 30A in an undeployed state.

[0063] Fig. 30C and 30C' illustrate perspective and side views of the interspinous spacer device of Fig. 30A in a partially deployed state.

[0064] Figs. 31A and 31B illustrate perspective views of another stabilizing device of the present invention in partial and fully deployed states, respectively.

Detailed Description of the Invention

[0065] Before the subject devices, systems and methods are described, it is to be understood that this invention is not limited to particular embodiments described, as such may, of course, vary. It is also to be understood that the terminology used herein is for the purpose of describing particular embodiments only, and is not intended to be limiting, since the scope of the present invention will be limited only by the appended claims.

[0066] Unless defined otherwise, all technical and scientific terms used herein have the same meaning as commonly understood by one of ordinary skill in the art to which this invention belongs.

[0067] It must be noted that as used herein and in the appended claims, the singular forms "a", "an", and "the" include plural referents unless the context clearly dictates otherwise. Thus, for example, reference to "a spinal segment" may include a plurality of such spinal segments and reference to "the screw" includes reference to one or more screw and equivalents thereof known to those skilled in the art, and so forth.

[0068] Where a range of values is provided, it is understood that each intervening value, to the tenth of the unit of the lower limit unless the context clearly dictates otherwise, between the upper and lower limits of that range is also specifically disclosed. Each smaller range between any stated value or intervening value in a stated range and any other stated or intervening value in that stated range is encompassed within the invention. The upper and lower limits of these smaller ranges may independently be included or excluded in the range, and each range where either, neither or both limits are included in the smaller ranges is also encompassed within the invention, subject to any specifically excluded limit in the stated range. Where the stated range includes one or both of the limits, ranges excluding either or both of those included limits are also included in the invention.

[0069] All publications mentioned herein are incorporated herein by reference to disclose and describe the methods and/or materials in connection with which the publications are cited. The publications discussed herein are provided solely for their disclosure prior to the filing date of the present application. Nothing herein is to be construed as an admission that the present invention is not entitled to antedate such publication by virtue of prior invention. Further, the

dates of publication provided may be different from the actual publication dates which may need to be independently confirmed.

[0070] The present invention will now be described in greater detail by way of the following description of exemplary embodiments and variations of the devices and methods of the present invention. The invention generally includes an interspinous spacer device as well as instruments for the percutaneous implantation of the interspinous spacer. A key feature of the interspinous spacer device is that it is expandable from a low profile configuration to a higher profile or operative configuration. This design allows the device, when in the low profile condition, to be delivered by percutaneous means without requiring the removal of any portion of the spinal motion segment into which the device is implanted.

[0071] As mentioned above, certain of the devices include balloon embodiments or those having expandable cavities which are expandable by the introduction of an inflation or expansion medium therein. Many of these are illustrated in Figs. 3-14. Certain other devices include those which have a more mechanical structure which is self-expandable upon release from a confined condition or which is actively expandable by actuation of another instrument. These are illustrated in Figs. 15-31.

[0072] Referring now to the drawings and to Figs. 3 and 4 in particular, an exemplary interspinous spacer device 24 of the present invention is illustrated in collapsed and expanded configurations, respectively. Interspinous device 24 includes an expandable spacer body 4 that has a size and shape when in the expanded condition for operative positioning between the spinous processes of adjacent superior and inferior vertebrae of the spinal motion segment being treated. Expandable body 34 is made of an expandable or inflatable biocompatible material such as non-porous material, e.g., latex, acrylate or a metal mesh, e.g., a nitinol or titanium cage.

[0073] Those spacers made of an inflatable non-porous material, i.e., balloon type spacers (see Figs. 3-10), are inflated with an inflation or expansion medium, such as air, saline, another biologically compatible fluid, or a flowable solid material, such as polyurethane, or a gel, which thickens or hardens substantially upon injection into balloon 34. In one embodiment, balloon 34 is initially inflated with air to provide some structure or rigidity to it to facilitate its optimum positioning and alignment between the spinous processes. Once positioned as desired, balloon 34 is injected with a flowable solid material (the air therein being displaced possibly via a vent hole within port 32). In certain embodiments, the expandable body is made of a non-compliant or semi-compliant material so as to maintain a substantially fixed shape or configuration and

ensure proper, long-term retention within the implant site. In other embodiments, the expandable member may be made of a compliant material. In any embodiment, the compressibility and flexibility of balloon 34 can be selected to address the indications being treated.

[0074] Other embodiments of the subject spacers are made of an expandable mesh or cage (see Figs. 11-12). The mesh or cage may be made of a super-elastic memory material which is compressible for delivery through a cannula and which is self-expanding upon implantation. Upon expansion, the mesh or cage may be self-retaining whereby its struts, links or wires are sufficiently rigid by themselves to maintain the expanded condition and withstand the natural forces exerted on it by spine. The mesh or cage may have an exterior coating or an interior lining made of materials similar to or the same as that used for the balloon spacers, or may otherwise be embedded in such material. In certain embodiments, an expansion medium may be used to fill the interior of the cage or mesh structure, such as with a biologically compatible fluid or flowable solid material used with the balloon-type embodiments.

[0075] In certain embodiments of present invention, either during the implant procedure or in a subsequent procedure, the size or volume of the implanted expandable spacer may be selectively adjusted or varied. For example, after an initial assessment upon implant, it may be necessary to adjust, either reduce or increase, the size or volume of the spacer to optimize the intended treatment. Further, it may be intended to only temporarily implant the spacer for the purpose of treating a temporary condition, e.g., an injured or bulging or herniated disk. Once the repair is achieved or the treatment completed, the spacer may be removed, either with or without substantially reducing the size or volume of the spacer. In other embodiments, the spacer as well as the inflation/expansion material may be made of biodegradable materials wherein the spacer degrades after a time in which the injury is healed or the treatment completed.

[0076] When unexpanded or deflated, as shown in Figs. 3A and 3B (balloon type) and in Figs. 11C and 11D (mesh type) expandable body 34 has a low profile, such as a narrow, elongated shape, to be easily translated through a delivery cannula 70. The shape of expandable body 34, when in an expanded or inflated state, has larger profile which is generally H-shaped. Expandable body 34 has lateral or side portions 30, end portions 26 and apexes 28 defined between the side portions 30 and the end portions 26. End portions 26 are preferably recessed or contoured to provide a narrowed central portion along the height dimension or major axis of expandable body 34 to readily fit between and to conform to the spinous processes.

Accordingly, expandable body 34 has an apex-to-apex dimension (i.e., height or major axis dimension) from about 3 to about 5 cm and a width dimension (minor axis dimension) from about 2 to about 4 cm

[0077] For those embodiments of expandable bodies which comprise a balloon configuration, balloon 34 has an inflation or injection port 32 at a sidewall 30 for coupling to a source of inflation or expansion material or medium. Port 32 may consist of a one-way valve which is self-sealing upon release from an inflation mechanism or tube 76. Port 32 is further configured to releasably engage from tube 76, where such engagement may be threaded or involve a releasable locking mechanism. Where the expandable body comprises a mesh or cage, port 32 simply acts as an exit port, however, where an expansion material is used, it also functions as an injection port for the expansion material.

[0078] Optionally, device 24 may include a pair of tabs 36 which may be positioned on one side of the device where the tabs 36 are preferably situated at the apexes 28 of expandable body 34. Pins or screws (not yet shown) may be used to secure the tabs against the spinous process to further ensure long-term retention of device 24 within the implant site. Tabs 36 are made of a biocompatible material, such as latex, acrylate, rubber, or a metal, and may be made of the same material used for the expandable member 34. Shown here attached to tabs 36 are tethers 38 which are used in part to manipulate the positioning of expandable body 34 upon implantation into the targeted spinal motion segment. The tethers may be made of any suitable material including but not limited to materials used to make conventional sutures. They may also be made of a biodegradable material. While two tabs and associated tethers are provided in the illustrated embodiment, one, three or more may be employed, where the respective tabs are located on the expandable body so as to be adjacent a bony structure of the vertebra suitable for anchoring thereto. In embodiments which do not employ securing tabs 36, tethers 38 may be attached directly to the expandable body itself.

[0079] Optionally still, device 24 may further include radiopaque markers 40 on the surface of expandable body 34 visible under fluoroscopic imaging to facilitate positioning of the expandable body. Any number of markers 40 may be employed anywhere on expandable body 34, however, as few as four markers, one at each apex, may be sufficient. With embodiments employing cage or mesh expandable bodies, the cage or mesh material itself may be radiopaque.

[0080] A system of the present invention includes a cannula device 70 having an outer sheath 72, a proximal hub 78 and preferably at least two interior lumens 74, 76 for the percutaneous

delivery the device and other tools for implanting the device, which tools may include a cutting instrument 62 (see Fig. 6C), a device delivery instrument 76, an endoscope, etc., which tools will be further discussed in the context of the description of the subject methods with reference to Figs. 5-10.

[0081] In Figs. 5A-5C, the spinal motion segment of Fig. 1 is illustrated having spinal ligament 54 extending between the superior spinous process 18 and the inferior spinous process 22. A percutaneous puncture is made into the skin 30 adjacent the target spinal motion segment of a patient undergoing the implantation of the interspinous device of the present invention, and a cannula 70 is penetrated to the spinous ligament 54. The puncture and subsequent penetration may be made by way of a sharp distal tip of cannula 70 or by a trocar (not shown) delivered through a lumen of cannula 70.

[0082] As illustrated in Figs. 6A-6C, the spinous ligament 54 is then dissected and an opening 58 created therein by way of a cutting instrument 60, such as a simple scalpel, an electrosurgical device or the like, delivered through a lumen of cannula 70. Cutting instrument 60 may then be removed from cannula 70 and, as illustrated in Figs. 7A-7D (balloon type) and in Figs. 11A-11D (cage type), a delivery instrument 16 having interspinous device 24 operatively preloaded is delivered through cannula 70.

[0083] The preloading of device 24 to delivery instrument 76 involves providing expandable body 34 in an unexpanded or deflated state and releasably coupled, as described above, by way of inflation or injection port 32 of expandable body 34 to the distal end of delivery instrument 76. In addition to functioning as a pusher, instrument 76 may act as an inflation lumen for balloon type embodiments through which an inflation medium is transported to within expandable body 34.

[0084] Depending upon the material used to fabricate expandable body 34, the expandable body may have a degree of stiffness in an unexpanded or deflated state such that it may maintain an elongated configuration so as to be directly insertable and pushable through cannula 70. This may be the case where the expandable member 34 is made of a cage or mesh material. Alternatively, a pusher or small diameter rod (not shown) may be inserted through inflation port 32 to within expandable body 34 to keep it in an elongated state so as to prevent expandable body 34 from bunching within cannula 70 and to provide some rigidity to more effectively position the expandable body in the target implant site. The rod is then removed from expandable body 34 and from delivery device 76 upon positioning the expandable body at the target implant site. In either case, expandable body 34 is folded or compressed about its

minor axis with the side wall opposite the inflation port 32 defining a distal end 25 (see Fig. 3B) and the apexes 28 of the expandable body folded proximally of distal end 25 to provide a streamline, low profile configuration for delivery through cannula 70.

[0085] Once interspinous device 24 is preloaded to delivery device 76 as just described, device 24 is then inserted into a lumen of cannula 70 with tethers 38 pulled back and trail proximally so that the tether ends 38a extend from hub 78 of cannula 70. Expandable body member 34 is translated through cannula 70 to within opening 58 within spinous ligament 54 as best illustrated in Figs. 7C and 11C. For best results, expandable body 34 is centrally positioned within opening 58 so that the countered ends 26 of expandable body 34 readily engage with the opposed spinous processes 18, 22. Fluoroscopy may be employed to visualize markers 40 so as to ensure that expandable body 34 centrally straddles the spinous ligament opening 58, i.e., the markers on the distal side 25 of the expandable body are positioned on one side of the spine and the markers on the proximal side of the expandable body (the side on which port 32 is located) are positioned on the other side of the spine.

[0086] Once centrally positioned, expandable body 34 is inflated or expanded, as illustrated in Figs. 8A-8D and 12A-12D. For balloon spacers, inflation occurs by allowing an inflation or expansion medium, as discussed above, to enter into the interior of the expandable body via port 32. For expandable mesh spacers, the expandable body may be configured to expand automatically upon exiting cannula 70. The inflation or expansion of expandable body 34 may also be visualized under fluoroscopy whereby markers 40, as best shown in Fig. 8C, are observed and the position of expandable body 34 may be adjusted to ensure optimum positioning upon complete inflation. Adjustments of the expandable body's position may be accomplished by manually pulling on one or both tether ends 38a which in turn pulls on tabs 26 to which the tethers 38 are attached at their proximal ends. The tethers 38 are selectively pulled as necessary to center or optimally position interspinous expandable body 34 to achieve the desired treatment of the targeted spinal motion segment.

[0087] With embodiments in which the expandable body is initially inflated with air and then filled with a solid or fluid medium, the latter is preferably not delivered or injected into the interior of the expandable body until the position of the expandable body within the interspinous space has been verified and optimized. This is beneficial in situations where, upon inflation, it is found that the expandable body is misaligned within the interspinous space and requires repositioning. The expandable body may simply be deflated of air to the extent necessary and repositioned in a less inflated or deflated state. If necessary, for example where it

is found that the maximum spacer or expandable body size is insufficient for the particular application at hand, expandable body 34 may be completely deflated and removed and replaced with a more suitably sized unit.

[0088] For balloon spacers and those mesh spacers which are not by themselves sufficiently self-retaining, once the position and extent of inflation or expansion of expandable body 34 are optimized, the expansion medium, e.g., polyurethane, is allowed to flow or injected into the interior of the expandable body via port 32. As illustrated in Figs. 9A and 9B, expandable body 34 is caused to expand to a selected volume and in so doing forces apart (see arrow 80) the spinous processes 18, 22 in between which it is situated. This selective distraction of the spinous processes also results in distraction of the vertebral bodies 2, 4 (see arrow 82) which in turn allows the disk, if bulging or distended, to retract to a more natural position (see arrow 84). Again, the extent of distraction or lordosis undergone by the subject vertebrae can be monitored by observing expandable body markers 40 under fluoroscopy.

[0089] The extent of possible distraction maybe limited by the capacity of expandable body 34 and the type of expandable body material employed. In certain embodiments, such as expandable bodies made of non-compliant or semi-compliant balloons, the requisite volume of the inflation medium may be substantially fixed whereby the balloon achieves its fully expanded configuration upon filling it with the fixed volume of medium. In other embodiments, such as with balloons made of a compliant material, the extent of expansion may be variable and selectable intraoperatively depending on the extent of lordosis or distraction to be achieved between the spinous processes in which balloon 34 is now interposed.

[0090] Upon achieving the desired distraction between the vertebrae, inflation/expansion lumen 76 is disengaged from expandable body port 32 which then becomes sealed by means of a one-way valve that is closed upon disengagement of lumen 76. Inflation/expansion lumen is then removed from cannula 70. While the opposing compressive force exerted on expandable body 34 by the distracted spinous processes 18, 22 may be sufficient to permanently retain expandable body 34 therebetween, the interspinous device may be further secured to the spinous processes 18, 22 to ensure that the expandable body does not slip or migrate from its implanted position. To this end, tabs 36 are anchored to the spinous processes as illustrated in Figs. 10A and 10B and in Figs. 13A and 13B. Any type of anchoring means, such as screws, tacks, staples, adhesive, etc. may be employed to anchor tabs 36. Here, cannulated screws 90 are used as anchors and are delivered to the target site releasably coupled to screw driving instrument 88. While various screw attachment and release mechanisms may be employed, a

simple configuration involves providing the screws 90 with a threaded inner lumen which is threadably engagable with the threaded distal end of instrument 88.

[0091] To ensure accurate placement of screws 90, along with instrument 88, can be tracked and translated over respective tethers 38, which function as guide wires. By manipulating instrument 88, the screws are driven or screwed into the respective spinous process. Screwdriver 88 is then disengaged or unscrewed from screw 90. After both tabs 36 are securely anchored to the spinous processes, the screwdriver and the cannula may be removed from the patient's back.

[0092] Figs. 14A-14F illustrate an alternative method for implanting the expandable member. In particular, the method contemplates pre-inflating or pre-expanding the expandable member prior to positioning the expandable member within the interspinous space. To accomplish this, the vertebrae 2 and 4 may be distracted prior to insertion of the pre-expandable balloon implant. A temporary distraction mechanism, such as another balloon or a mechanically actuated device, is inserted into the interspinous space. When the desired amount of distraction is achieved, the permanent or implantable expandable member can then be placed within the interspinous space, and the temporary distraction member may then be removed from the space.

[0093] While certain of the expandable spacers are intended to be permanently implanted within a spine, certain others may be implanted only temporarily to facilitate the healing of an injury or the treatment of a reversible or non-chronic condition, such as a herniated disk. For such temporary treatments, the expansion material most likely is a fluid, such as saline, which may be easily aspirated through port 32 or may be allowed to drain out via a penetration or cut made in the expandable member. In those embodiments in which the expansion material is a flowable solid, which may or may not subsequently harden within the expandable member, the material may be one that is reconstitutable into a liquid form which may then be subsequently aspirated or evacuated from the expandable member. For percutaneous removal of the expandable member, a cannula such as cannula 70 may be used and an aspiration instrument delivered therethrough and coupled to port 32. After deflation and/or evacuation of the expandable member, and removal of the tacks, sutures, staples, etc. if such are used to secure tabs 36, the expandable member may be easily removed through cannula 70. With biodegradable spacers, removal of the spacer is obviated.

[0094] It should be noted that any of the above-described steps or procedures, including but not limited to cannulation of the target area, dissection of the spinous ligament, insertion of the expandable body within the dissected opening of the spinous ligament, inflation and/or

expansion of the expandable body, adjustment or readjustment of the expandable body, and anchoring of the tabs, etc., may be facilitated by way of a scope 62 delivered through a lumen of cannula 70 to the open distal tip of cannula 70. Alternatively, a second cannula delivered through another percutaneous penetration may be employed for use of an endoscope and any other instruments needed to facilitate the procedure.

[0095] Fig. 14A illustrates an exemplary embodiment of a temporary distraction mechanism 100 having an expandable strut configuration. Mechanism 100 includes bilateral struts 102 which are hinged and foldable at hubs 104, respectively. Bridging the struts 102 at superior and inferior ends are spinous process engagement portions 106 which are preferably configured to conformingly engage with the spinous processes 18, 22. Extending centrally between hubs 104 is a distal portion of guide wire 108, which also extends proximally through proximal hub 104a. Guide wire 108 is in threaded engagement with both hub 104a whereby hub 104a can be translated both proximally and distally along guide wire 108. As such, expandable member 100 can be provided in a low profile, compressed state upon proximally translating hub 104a in a proximal direction. In such a low-profile state, distraction mechanism 100 is easily deliverable through cannula 70, as described above, to with the interspinous space. Upon proper positioning, distraction mechanism 100 is expandable to a higher profile or expanded state by translating hub 104a toward hub 104b in a distal direction along guide wire 108, as illustrated in Fig. 14A.

[0096] After the desired amount of distraction is achieved between vertebrae 2 and 4, an implantable expandable member 110 of the present invention is delivered adjacent the distracted spinal motion segment. Expandable member 110 may be delivered from the same incision and side as distraction mechanism 100 (ipsilateral approach) and as well as through the same working channel, or may be delivered through a different incision on the same or opposing side of the spinal motion segment being treated (bilateral approach) using two different working channels. In the illustrated embodiment, expandable member 110 is delivered from the same side of the spinous process as distraction mechanism 100. Expandable member 110 may delivered through a separate designated lumen in cannula 70 and translated distally of hub 104b of distraction mechanism 100.

[0097] As shown in Fig. 14B, after deployment, expandable member 110 is inflated or expanded as described above with respect to expandable member 34, for example, by way of an inflation lumen extending through guide wire 108. Tethers 112 may be provided on expandable member 110 to retract and manipulate it to within the interspinous space, as illustrated in Fig.

14C. Once expandable member 110 is properly positioned within the interspinous space, distraction mechanism 100 may be removed from the interspinous space immediately or, if the expandable member has been filled with a curable expansion medium or one that involves setting or hardening, the distraction mechanism may be kept in the interspinous space until the desired consistency, curing or hardening has been achieved by the expansion medium. To remove distraction mechanism 100 from the interspinous space, its profile is reduced to a low profile state, as illustrated in Fig. 14D. As mentioned earlier, this is accomplished by translating proximal hub 104a proximally along guide wire 108. Distraction member 100 may be retracted out through a cannula or removed directly in this low profile state, leaving expandable member 100 alone within the implant site as illustrated in Fig. 14E. Tethers 112 may then be cut or secured in place. Optionally, a strap 116 or the like may be implanted to further secure expandable member 110 within the implant site and reduce the risk of migration. Here, bores or holes 114 have been formed through the thickness of the spinous processes 18, 22 and strap 116 threaded there through with its ends secured together by a securing means 120, such as a suture, staple or clip, as illustrated in Fig. 14F. Alternatively, strap 116 could be wrapped around the spinous processes 18, 22.

[0098] In addition to the expandable balloon spacers, the present invention further provides for mechanically expandable spacers such as those illustrated in Figs. 15-17. For example, expandable spacer 130 of Fig. 15A is a cage-like structure having spaced-apart, parallel strut members 132 extending between and fixed to hubs 134. Like the distraction mechanism of Figs. 14A-14F, spacer 130 may be provided on and deliverable by way of a guide wire 136 which is threadably engaged to and disengagable from proximal hub 134a. After placement of spacer 130 within the interspinous space, as illustrated in Fig. 15A, spacer 130 is expanded by advancing proximal hub 134a distally along guide wire 136 thereby forcing struts 132 radially outward and away from each other whereby the expanded configuration of spacer 130 is elliptical or, in a more advanced state of expansion, substantially spherical. Once the desired degree of distraction is achieved between vertebrae 2 and 4, guide wire 136 unthreaded from hub 134a and removed from the implant region.

[0099] Figs. 16A and 16B illustrate another embodiment of an expandable spacer 140 which is in the form of a coiled band 142 terminating at an outer end 144 having a configuration for receiving and locking onto inner end 146 upon full expansion or unwinding of the coil. The diameter of coil 142 in an unexpanded or fully wound state is small enough to allow easy insertion between spinous processes 18, 22. Upon proper positioning within the interspinous

space, coil 142 is allowed to expand and unwind thereby distracting vertebrae 2 and 4 apart from each other. Once the desired level of distraction is achieved, inner end 146 is coupled to outer end 144. While the figures show band 142 inserted transversely to spinous processes 18, 22, it may alternatively be inserted in line or in the same plan defined by the spinous processes.

[00100] Figs. 17A-17C illustrate another interspinous spacer 150 having interlocked nested portions 152. Nested portions 152 are each shaped and configured to be received within one of its adjacent portions and to receive the other of the adjacent portions when in a low profile state, as illustrated in Fig. 17A. Upon expansion of spacer 150, which may be spring loaded or be expandable by way of an instrument (not shown) which may be inserted into the spacer's center and rotated to flare portions 152, vertebrae 2 and 4 are caused to distract from each other. Portions 152 may have a configuration or shape which allows them to bite or dig into the spinous process 18, 22 and become securely retained therein.

[00101] Figs. 18A and 18B illustrate another interspinous spacer 160 of the present invention in an undeployed or unexpanded state and a deployed or expanded state, respectively. Spacer 160 includes an expandable tubular member 162 having end portions 164a, 164b which are capped by hubs 166a, 166b, respectively. As is explained in greater detail below, one or both hubs may be provided fixed to tubular member 162 or may be releasably coupled thereto. A sleeve or retaining member 168 is circumferentially positioned about tubular member 162 between end portions 164a, 165a. Most typically, retaining member 168 is positioned substantially centrally (as shown) on tubular member 162, but may be positioned laterally towards one or the other end. Retaining member 168 has a length that covers about one third of the length of tubular member 162, but may be longer or shorter depending on the application. As is explained in greater detail below, interspinous spacer 160 may further include a core member (shown in Fig. 21) within the lumen of the tubular member and which may be provided integrated with spacer 160. Alternatively, the core member may be provided as a detachable component of the device used to deliver and implant the spacer (see Figs. 19A and 19B).

[00102] In the undeployed state, as illustrated in Fig. 18A, spacer 160 has an elongated tubular or cylindrical shape, and may have any suitable cross-sectional shape, e.g., circular, oval, starred, etc., where the more angular cross-sections may allow the device to bite or dig into the spinous processes and for better retention. In this undeployed or lengthened state, tubular member 162 has a length in the range from about 20 mm to about 80 mm, and more typically from about 30 mm to about 50 mm, and a diameter or average thickness in the range from about 4 mm to about 12 mm, and more typically from about 6 mm to about 9 mm. As such, spacer

160 is deliverable to an implant site between adjacent spinous processes in a minimally invasive manner.

[00103] In the deployed state, as illustrated in Fig. 18B, spacer 160 has a dumbbell or H-shaped configuration, where the length of spacer 160 is less than and the diameter or height of spacer 160 is greater than the corresponding dimensions of the spacer when in an undeployed state. In particular, the length dimension of the end portions 164a, 164b of tubular member 162 has been reduced by about 25% to about 70% while the diameter of the end portions 164a, 164b has been increased by about 50% to about 600%, and the diameter of the central or sleeve-covered portion has been increased by about 200% to about 400%, where the diameter of the portions of the tubular member 164a, 164b not covered by retaining member 168 have a greater diameter than the portion of tubular member 162 which is covered by retaining member 168. The increased diameter of covered or central portion 168 distracts the adjacent vertebrae so as to provide pain relief. The diameter of hubs 166a, 166b may remain constant upon deployment of device 160. In this deployed state, tubular member 162 has a length in the range from about 15 mm to about 50 mm, and more typically from about 20 mm to about 40 mm, and an end portion diameter in the range from about 10 mm to about 60 mm, and more typically from about 15 mm to about 30 mm, and a central portion diameter in the range from about 5 mm to about 30 mm, and more typically from about 8 mm to about 15 mm. As such, when operatively placed and deployed within an interspinous space, the deployed spacer 160 fits snugly within the interspinous space and is held in place by the surrounding muscle, ligaments and tissue.

[00104] Any suitable materials may be used to provide a spacer 160 which is provided in a first state or configuration, e.g., the undeployed state illustrated in Fig. 18A, and which can be manipulated to achieve a second state or configuration, and back again if so desired. A polymer based material or any other material which allows for simultaneous axial shortening and radial expansion is suitable for use to form tubular member 162. The end portions 164a, 164b may be made of the same or a different material as that of the central or covered portion. A flexible or shaped memory material or any other material which also allows for simultaneous axial shortening and radial expansion, but which is less expandable, i.e., maintains a compressive force about tubular member 162, than the material employed for tubular member 162 may be used to form retaining member 168. As such, retaining member 168 limits the extent of radial expansion as well as axial shortening that the covered portion of tubular member 162 can undergo. Examples of suitable materials for the retaining member include but are not limited to Nitinol or polyethylene in a braided or mesh form. Further, the construct of retaining member

168 may be such that the radial force applied to the portion of tubular member 162 that it covers is constant or consistent along its length so as to maintain a constant diameter along its length or, alternatively, may have a varying radial force so as to allow for selective shaping of the covered portion of tubular member when in a deployed state. Retaining member 168 may be constructed so as to resist bending or flexing upon forcible contact with the spinous processes and, as such, does not conform to the spinous processes. Conversely, the retaining member 168 may be constructed from a more flexible material that allows for some compression and, as such, may conform or be conformable to the spinous processes. Further, the physical properties and dimensions of the materials used for both the tubular member and the retaining member may be selected to provide the desired amount of distraction between target vertebrae.

[00105] Referring now to Figs. 19A and 19B, spacer 160 is shown operatively employed within an interspinous space and coupled to delivery device 170. Delivery device 170 includes an outer shaft 172 and an inner shaft 178, movable relative (axially, rotationally or both) to outer shaft 172, both extending from a handle mechanism 174. For example, inner shaft 178 may be configured to be retracted proximally within outer shaft 172, or outer shaft 172 may be configured to be advanced distally over inner shaft 178, or both configurations may be employed together, i.e., while outer shaft 178 is advanced, inner shaft 178 is retracted. The relative movement may be accomplished in any suitable manner, for example by way of a screw configuration, i.e., where the shaft members engage by way of corresponding threads, as illustrated in Fig. 20A, or by way of a ratchet configuration, as illustrated in Fig. 20B. The relative movement is accomplished by manual actuation of actuator 176 coupled to handle 174. While only mechanical embodiments of the movement actuation are illustrated, the same can be achieved by electrically or pneumatically-driven devices or mechanisms.

[00106] As mentioned above, spacer 160 may be provided with an integrated core member or the core member may be detachably provided on the distal end 182 of inner shaft 178. In the first embodiment, distal end 182 of inner shaft 178 is configured to temporarily couple with a proximal end (i.e., the end closest to handle 174) of the core member. In the latter embodiment, the distal end 182 of inner shaft 178 is configured to be inserted into the lumen of tubular member 162, as illustrated in Fig. 21, connect to or engaged with distal hub 166b (i.e., the hub positioned furthest from handle 174) and be detachable at a proximal end 184 from inner shaft 178 to function as a core member. An advantage of the latter embodiment is that the end portion 182 of the inner shaft 178 functioning as the core member may have a length that is as short as the length of tubular member 172 when in a deployed state, with no extra length or

remaining portion extending laterally of the implanted device. In the integrated embodiment, the core length may need to be as long as tubular member 172 when in the undeployed state. However, the core member may be segmented to allow for selective removal of one or more lengths or portions from the proximal side of the core member subsequent to implantation of the spacer so as not to have any excess length extending from the spacer.

[00107] With either embodiment, retraction of inner shaft 178, as described above, retracts distal hub 166b towards proximal hub 166a and/or advancement of outer shaft 172 advances proximal hub 166a towards distal hub 166b, thereby causing tubular member 162 to be compressed axially, and thus expanded radially, as shown in Fig. 19B. While distal hub 166b may be fixed to tubular member 162, proximal hub 166a may be provided as a separate component having a central bore which allows it to receive and axially translate over inner shaft 178. Proximal hub 166a may be configured to readily slide over inner shaft 178 in a distal direction (but possibly not in a proximal direction) or may be threaded in order to advance over inner shaft 178. The advancement of proximal hub 166a axially compresses tubular member 172 and causes it to radially expand. The axial compression or radial expansion may be continued until the desired extent of distraction occurs between vertebrae 2 and 4. When the desired level of distraction is achieved, proximal hub 166a is secured to either the proximal end of tubular member 162 and/or the proximal end of the core member 182, such as by a threaded or snap-fit engagement or by activating a lock mechanism (not shown). Inner shaft 178 may then be released from the core member (or distal end 182 of inner shaft 178 may be released from inner shaft 178 and left within tubular member 172 to function as the core member) which, along with the end hubs 166a and 166b, maintain the implanted spacer 160 in a deployed state so as to maintain distraction between the vertebrae.

[00108] The reconfiguration of spacer 160 may be further facilitated by selectively configuring the wall of tubular member 162. For example, the interior or luminal surface of tubular member 162 may be contoured or incorporated with divets or spaces 180 where, upon compression of tubular member 162, the walls of the uncovered portions 164a, 164b of tubular member 162 will more readily fold inward to provide the resulting configuration shown in Fig. 18B.

[00109] Figs. 22A-22C illustrate another interspinous spacer 190 of the present invention in an undeployed/unexpanded state, in an intermediate state during deployment and in a deployed/expanded state, respectively. Spacer 190 includes expandable end portions 192a, 192b which are capped by hubs 198a, 198b, respectively. As mentioned previously, one or both hubs may be provided fixed to the end members or may be releasably coupled thereto.

Extending between end portions 192a, 192b is a central portion 194 including a plurality of blocks or wedges, such as side blocks 200 and end blocks 202, surrounded by a cover, sleeve or retaining member (not shown) which functions to hold the blocks in frictional engagement with each other. A core member or rod 196 extends centrally through end portions 192a, 192b and central portion 194 where end blocks 202 are coaxially positioned on core 196 and are slidably translatable thereon. Core member 196 or a portion thereof may be provided integrated with spacer 190 or may be provided as a detachable component of the device used to deliver and implant the spacer.

[00110] As with the previously described spacer, end portions 192a, 192b may be made of a polymer based material or any other material which allows for simultaneous axial shortening and radial expansion when compressed. Blocks 200, 202 have a more rigid configuration in order to distract the adjacent spinous processes which define the interspinous space into which spacer 190 is positioned without substantial compression of central portion 194. As such, the blocks may be made of a rigid polymer material, a metal, ceramics, plastics, or the like. In order to effect radial expansion and axial shortening of central portion 194, the blocks are selectively sized, shaped and arranged such that an inwardly compressive force on end blocks 202 along the longitudinal axis of the spacer forces end blocks 202 together which in turn forces side or lateral blocks 200 outward and away from each other, as illustrated in Fig. 22B. The inwardly tapered sides of the blocks enable slidable engagement between adjacent blocks. The covering (not shown) around the blocks is made of a stretchable material so as to accommodate the radial expansion of central portion 194. As such, the cover may be made of a polymer based material.

[00111] When in an undeployed state, as shown in Fig. 22A, the central and end portions of spacer 190 have tubular or cylindrical configurations, and may have any cross-sectional shape, length and or diameter as provided above with respect to spacer 160 of Figs. 18A and 18B. Deployment of spacer 190 within an interspinous space may be accomplished in the manner described above. In a fully deployed state, as illustrated in Fig. 22C, spacer 190 has a dumbbell or H-shaped configuration with a change in length and height dimensions as provided above. The increased diameter of central portion 194 when spacer 190 is the deployed configuration distracts the adjacent vertebrae so as to provide pain relief. While the respective dimensions of the spacers change from an undeployed to a deployed state, the spacers may be configured such that the overall size of volume occupied by the spacer does not change.

[00112] Another interspinous spacer 210 of the present invention is illustrated in an undeployed/unexpanded state, in an intermediate state during deployment and in a deployed/expanded state in Figs. 23A-23C, respectively. Spacer 210 includes expandable end portions 212a, 212b capped by hubs 224a, 224b, respectively. As mentioned previously, one or both hubs may be provided fixed to the end members or may be releasably coupled thereto. Extending between end portions 212a, 212b is a central portion 214 including a plurality of linkages 216 and blocks 220, 222, which collectively provide opposing struts. Each linkage 216 has a length and is pivotally coupled to a side block 220 and an end block 222, where end blocks 222 are coaxially positioned on core 218 and are slidably translatable thereon. While the materials and configuration of end portions 212a, 212b may be as described above, linkages 216 are preferably made of a metal material. A core member or rod 218 extends centrally through end portions 212a, 212b and central portion 214. Core member 218 or a portion thereof may be provided integrated with spacer 210 or may be provided as a detachable component of the device used to deliver and implant the spacer.

[00113] In an undeployed state, as shown in Fig. 23A, the central and end portions of spacer 190 have tubular or cylindrical configurations, and may have any cross-sectional shape, length and or diameter as provided above. As such, side blocks 220 are close together and end blocks 222 are spaced apart with the lengths of linkages 216 aligned with the longitudinal axis of core member 218. When opposing, inwardly compressive forces are exerted on spacer 210 along its longitudinal axis, end portions 212a, 212b axially compress and radially expand as described above thereby forcing end blocks 222 together which in turn force side or lateral blocks 220 outward and away from each other, as illustrated in Fig. 23B. This action causes linkages 216 to spread apart, as shown in Fig. 23B, and move to positions where their lengths are transverse to the longitudinal axis of core 218, as illustrated in Fig. 23C.

[00114] Interspinous spacer 230 of Figs. 24A-24C employs the linkage arrangement of the central portion of spacer 190 of Figs. 23A-23C in both of its end portions 232a, 232b as well as its central portion 234. Specifically, end portions 232a, 232b employ linkages 236, which are longer than linkages 238 used for central portion 234, but which are arranged in similar engagement with side blocks 248 and end blocks 250. On each side of central portion 234 and in between the central portion and the end portions 232a, 232b, respectively, are dampening washers 244. A core member 240 extends between and through the end blocks 250 of distal end member 232a and the end blocks 252 of central portion 234 as well as the dampening washers 244 positioned therebetween, all of which, except the most distal end block, may

slidably translatable along core member 240. Core member 240 is releasably attached at a proximal end to ratcheted drive rod 242 of a delivery device as discussed above with respect to Figs. 19-21 which rod 242 extends through the proximal end portion 232a and hub 246, as illustrated in Fig. 24B.

[00115] In an undeployed state, as shown in Fig. 24A, the central and end portions of spacer 230 have tubular or cylindrical configurations. As such, side blocks 248 and 252 of end portions 232a, 232b and central portion 234, respectively, are close together and end blocks 250 and 252 of end portions 232a, 232b and central portion 234, respectively, are spaced apart with the lengths of linkages 236, 238 aligned with the longitudinal axis of core member 240. When opposing, inwardly compressive forces are exerted on the distal block 250 and hub 246 of spacer 230 along its longitudinal axis, the end blocks are drawn together thereby forcing side or lateral blocks 220 outward and away from each other, as illustrated in Fig. 24B. This action causes the linkages of the end and central portions to spread apart, and move to positions where their lengths are transverse to the longitudinal axis of core 240, as illustrated in Fig. 24C, the fully deployed state of spacer 230.

[00116] The end portions and central portions of the compressible spacers described above may be used in any combination. For example, the polymer-based central portion of Figs. 18A and 18B and the linkage end portions of Figs. 24A-24C may be used together to form a spacer of the present invention. Such a spacer 260 is illustrated in Figs. 25A-25C. Spacer 260 includes linkage-block end portions 262a, 262b and a compressible central member 264 around which is positioned a circumferential retaining member 278 made of a braided mesh-like material. A core member 274 extends between and through the end blocks 270 of distal end member 262a and through central portion 264, all of which, except the most distal end block, may slidably translatable along core member 260. Core member 260 is releasably attached at a proximal end to ratcheted drive rod 272 of a delivery device as discussed above with respect to Figs. 19-21 which rod 272 extends through the proximal end portion 262a and hub 272, as illustrated in Fig. 25B.

[00117] In an undeployed state, as shown in Fig. 25A, the central and end portions of spacer 230 have tubular or cylindrical configurations. As such, side blocks 268 of end portions 262a, 262b are close together and end blocks 270 of end portions 262a, 262b are spaced apart with the lengths of linkages 266 aligned with the longitudinal axis of core member 274. When opposing, inwardly compressive forces are exerted on the distal block 270 and hub 272 of spacer 260 along its longitudinal axis, the end blocks are drawn together thereby causing

linkages 266 of the end portions to spread apart thereby forcing side or lateral blocks 268 outward and away from each other, as illustrated in Fig. 25B, until linkages 266 move to positions where their lengths are transverse to the longitudinal axis of core 274, as illustrated in Fig. 25C, the fully deployed state of spacer 260.

[00118] Each of the expandable and or inflatable interspinous spacers described thus far is particularly configured to be delivered minimally invasively, even percutaneously, from a single incision located laterally to one side (left or right) of the spinal motion segment to be treated. However, the present invention also includes interspinous spacers which are deliverable through a mid-line incision made directly into the interspinous ligament. Examples of such spacers are now described.

[00119] Figs. 26A and 26B are perspective and front views, respectively, of interspinous spacer 280 which is configured for implantation by way of a percutaneous mid-line approach. Spacer 280, shown in a deployed state, includes a central member or portion 282 and four struts or legs 284 which are substantially radially expandable from central portion 282. Central portion 282 has a cylindrical configuration having a diameter sized for delivery through a small gauge cannula and a length that allows placement within an interspinous space. A lumen 285 extends at least partially through the center of central portion 282 and is configured, e.g., threaded, to be releasably engaged to a delivery tool.

[00120] Each strut 284 includes one or more blocks 288. Where more than one block 288 per strut is employed, such as with spacer 280 which employs two blocks 288 per strut 284 and spacer 290 of Fig. 27 which employs three blocks 288 per strut 284, the blocks are stacked and slidably interconnected to each other in a manner that allows the to translate linearly relative to each other along parallel axes. A tongue and groove configuration 292 is employed with the illustrated embodiment to interconnect stacked blocks, but any suitable interconnection which enables such relative motion between the blocks may be used. Such configuration may also be employed to interconnect the innermost block to central member 282 where outer ridges or tongues 296 on central member 282 slidably interface with a corresponding groove on inner end of the innermost block. As such, blocks 288 are slidable relative to central member 282 along an axis parallel to the longitudinal axis of central member 282. Depending on the application and the particular anatomy of the implant site, struts 284 may be evenly spaced apart about the circumference of central member 282. In other embodiments the distance between superior struts 284a and between inferior struts 284b may vary and/or the distance between each of those and between struts on the same side of the central member may vary.

- [00121] Spanning between each strut pair 284a and 284b is a strap 286a and 286b, respectively, affixed to the outermost blocks. Straps 286 may be made of any suitable material which is strong enough to maintain distraction between adjacent spinous processes and to endure any frictional wear which it may undergo due to natural spinal motion. The straps may be flexible such that they act as slings, or may be conformable to the spinous processes once in situ. Alternatively, the straps may be non-conforming and rigid with a planar or curved shape depending on the application at hand. Suitable strap materials include but are not limited to polyester, polyethylene, etc.
- [00122] With reference to Figs. 28A-28E, various steps of a method according to the present invention for implanting spacer 280 as well as other spacers of the present invention configured for a mid-line implantation approach into a target spinal motion segment (defined by components of vertebral bodies 2 and 4) of a patient are described.
- [00123] The initial steps of creating a percutaneous puncture and subsequent penetration into the skin 30 and the dissection of the spinous ligament 54 involve many of the same instruments (e.g., K-wire, trocar, cutting instrument, delivery cannula, etc.) and surgical techniques used in the ipsilateral implantation approach described above with respect to Figs. 5 and 6. Upon creating an opening within the interspinous space extending between the superior spinous process 18 and the inferior spinous process 22, a delivery instrument 300 having interspinous device 280 operatively preloaded in an undeployed state at a distal end is delivered to within the interspinous space. The delivery instrument 300 is provided with a mechanism for releasably connecting to spacer 380, such as by way of threaded screw 302 (see Fig. 28D) which is threadedly engaged with threaded lumens 285 of spacer 280.
- [00124] As best illustrated in Figs. 28A' and 28A'', when in an undeployed state, spacer 280 has a relatively low profile to facilitate entry into the interspinous space. Once properly positioned within the interspinous space, deployment of the spacer 280 is initiated, as illustrated in Fig. 28B, by manipulation of instrument 300 which simultaneously causes outward radial movement of the outermost blocks of strut pairs 284a, 284b and distal linear advancement of the proximal portion 304 of spacer 282 (see Figs. 28B' and 28B'') resulting in radial expansion and axial shortening of spacer 280. Spacer 280 may be configured such that deployment of the struts is accomplished by either or both axial rotation of internally componentry or axial compression of central member 282.
- [00125] As the struts are radially extended, straps 286a and 286b emerge and they become tauter as the slack in them is gradually reduced by the extension of the struts. Continued deployment

of spacer 280 causes straps 286a, 286b to engage with opposing surfaces of spinous processes 18 and 22. The radial extension of the struts is continued, as illustrated in Figs. 28C, 28C' and 28C", until the desired amount of distraction between the vertebra is achieved. This selective distraction of the spinous processes also results in distraction of the vertebral bodies 2, 4 which in turn allows the disk, if bulging or distended, to retract to a more natural position. The extent of distraction or lordosis undergone by the subject vertebrae can be monitored by observing the spacer under fluoroscopy.

[00126] At this point, the delivery instrument 300 is released from spacer 280 by unscrewing threaded screw 302 from threaded lumen 285 and removing it from the implant site, as illustrated in Fig. 28D. Spacer 280 remains behind within the interspinous space, locked in a deployed state (see Fig. 28E).

[00127] Spacer 280 may be configured such that the struts are not retractable without active manipulation of delivery instrument 300 to ensure that their extension, and thus the distraction on the spinal motion segment, is maintained. As configured, spacer 280 may be easily repositioned or removed by subsequent insertion of instrument 300 into the interspinous space and operative engagement with the spacer. Instrument 300 is then manipulated to cause retraction of the struts and the straps, reducing the spacer's profile to allow repositioning or removal of the spacer.

[00128] Figs. 29A-29D illustrate another spacer 310 of the present invention that is implantable through a mid-line approach to the interspinous space. Spacer 310 includes centrally opposed front and rear structures or blocks 312a, 312b which are pivotally interconnected on both sides to pairs of elongated linkages 314. The other end of each linkage 314 is pivotally connected to a lateral structure 318a or 318b. The resulting "X" configuration provides interconnected strut pairs on each side of spacer 310 which move and function similarly to the linkages described above with respect to the spacers illustrated in Figs. 23, 24 and 25, i.e., the lengths of linkages 314 extend parallel to the central axis of spacer 310 when in a fully undeployed state (Fig. 29A) and extend transverse to the central axis of spacer 310 in a fully deployed state (Fig. 29D). Extending between opposing superior lateral structures 318a and between opposing inferior structures 318b are straps 316a and 316b, respectively.

[00129] Spacer 310 is implantable and deployable by way of a mid-line approach similar to that described above with respect to the spacer of Figs. 28A-28E. Spacer 310 is preloaded to a delivery instrument shaft 320 which is insertable and axial translatable through a central opening within front block 312a. The distal end of shaft 320 is releasably attached to an axial

member (not shown) of spacer 310. Axial member is fixed to rear block 312b and extends along the central axis of spacer 310, having a length which extends to front block 312a when spacer 210 is in a fully deployed state, as illustrated in Fig. 29D but which extends only a portion of the length of spacer 310 when it is in an undeployed state (Fig. 29A) or a partially undeployed (Figs. 29B and 29C) state.

[00130] After the necessary space is created within the interspinous space as described above, spacer 310, which is releasably connected to delivery shaft 320 as described above, is inserted into the space in a fully undeployed state (see Figs. 29A and 29A'). Deployment of the spacer is accomplished by proximally pulling on shaft 320 which compresses rear block 312b towards front block 312a. This in turn causes the linkages 314 to pivot about their respective attachment points with superior and inferior lateral structures or blocks 318a and 318b forced away from each other, as illustrated in Figs. 29B and 29B'. Continued pulling of instrument 320 further expands linkages 314 in a direction transverse to the central axis of spacer 310 and extend straps 316a, 316b towards respective surfaces of the spinous processes. As front and rear blocks 312a and 312b are centrally tapered, defining a bowtie or hourglass configuration, the strut pairs define a centrally tapered profile as they align to their fully deployed position, as best shown in Figs. 29C' and 29D'. In the fully deployed state, the spacer's axial member is positioned within the opening of front block 312a and locked to it. Additionally, straps 316a and 316b are firmly engaged against the spinous processes and the contacted vertebra are distracted from each other. Delivery instrument 320 may then be released from spacer 310 and removed from the implant site.

[00131] Figs. 30A-30C illustrate yet another spacer 330 of the present invention having an "X" shape in an expanded condition and which is implantable through a mid-line approach to the interspinous space. As best illustrated in Figs. 30A and 30A', spacer 330 includes an elongated central member 332 extending between front and rear hubs 334a and 334b and a plurality of flexible or deformable struts 336 which also extend between hubs 334a, 334b. Struts 336 are configured to be deformable and to have a directional character to facilitate deployment of them radially outward from central member 332. Examples of suitable constructs of these struts include but are not limited to thin metal plates, e.g., flat springs, wire bundles or a polymer material. Extending between and affixed to each of strut pairs 336a and 336b are straps 338a and 338b, respectively.

[00132] The proximal end 342 of central member 332 is provided with ratcheted grooves which are releasably engaged within the distal end of 352 of delivery instrument 350 (see Fig. 30C').

Front hub 334a is provided with an opening 340 which also has a grooved internal surface for engaging with the grooves of central member 332.

[00133] Spacer 330 is implantable and deployable by way of a mid-line approach similar to that described above with respect to the spacer of Figs. 29A-2D. Spacer 330 is preloaded in a fully undeployed state to delivery instrument shaft 350 as illustrated in Figs. 30B and 30B'. After the necessary space is created within the interspinous space as described above, spacer 330 is inserted into the interspinous space. Deployment of the spacer is accomplished by proximally pulling on shaft 350, by ratcheting as described above, which compresses rear hub 334b towards front hub 334a or distally pushing on front hub 334a towards rear hub 334b. This in turn causes struts 336a, 336b to flex or bend outward, as illustrated in Figs. 30C and 30C'. Continued pulling of instrument 350 (or pushing of hub 334a) further bends the struts such that they define an X-shaped structure with straps 338a and 338b forcibly abutting against the interspinous processes. The pulling (or pushing) action advances the grooved proximal end 342 of central member 332 into grooved opening 340 of front hub 334a. The opposing grooves of the central member and the opening provide a ratchet relationship between the two whereby central member is readily translatable in a proximal direction but not in a distal direction, thereby locking spacer 330 in a deployed state. Upon achieving the desired amount of distraction between the vertebra, delivery instrument 350 is released from spacer 310 (such as by unscrewing) and removed from the implant site.

[00134] Figs. 31A and 31B illustrate a stabilizing spacer 360 similar to spacer 330 just described but which forms the expanded "X" configuration with solid linkages rather than struts. Spacer 360 includes an elongated central member 362 extending from and fixed to a rear hub 364a and slidably through a front hub 364b proximally to a delivery tool having a shaft 372. Also extending between the front and rear hubs are four linkage pairs, where each linkage pair 366a and 366b are interconnected to a respective hub by a hinge 368 and are interconnected to each other by a hinge 370. When in a fully unexpanded condition, each linkage pair extends parallel to central member 362, providing a low profile for delivery. When the front and rear hubs are caused to approach each other, each linkage pair 366a, 366b expands substantially radially outward from central member 362, as illustrated in Fig. 31A. The hubs are brought together to the extent desired to provide an expanded "X" configuration, as illustrated in Fig. 31B. Upon achieving the desired expansion, central member 362 is released or detached from delivery shaft 372. As with many of the "mechanical" type spacers discussed above, attachment and release of the spacer from the delivery device may be accomplished by various means, including but

not limited to ratchet, threaded or quick-release configurations between the spacer and the delivery device.

[00135] Extending between and affixed to each of the top and bottom linkage pairs are brackets or saddles 374 for receiving the inner surfaces of opposing interspinous processes. Brackets 374 have a substantially rigid and flat central portion 374a and relatively flexible lateral portions 374b which are affixed to hinges 370. The rigid, flat central portion 374a facilitates engagement with the interspinous process. The flexible lateral portions 374b and their hinged connections to spacer 360 facilitate folding of the lateral portions 374b when in an undeployed state and allow for adjustment of spacer 360 once in a deployed state, where at least a portion of the adjustment may be self-adjustment by spacer 360 relative to interspinous space into which it is implanted.

[00136] The subject devices and systems may be provided in the form of a kit which includes at least one interspinous device of the present invention. A plurality of such devices may be provided where the devices have the same or varying sizes and shapes and are made of the same or varying biocompatible materials. Possible biocompatible materials include polymers, plastics, ceramic, metals, e.g., titanium, stainless steel, tantalum, chrome cobalt alloys, etc. The kits may further include instruments and tools for implanting the subject devices, including but not limited to, a cannula, a trocar, a scope, a device delivery/inflation/expansion lumen, a cutting instrument, a screw driver, etc., as well as a selection of screws or other devices for anchoring the spacer tabs to the spinous processes. The kits may also include a supply of the expandable body inflation and/or expansion medium. Instructions for implanting the interspinous spacers and using the above-described instrumentation may also be provided with the kits.

[00137] The preceding merely illustrates the principles of the invention. It will be appreciated that those skilled in the art will be able to devise various arrangements which, although not explicitly described or shown herein, embody the principles of the invention and are included within its spirit and scope. Furthermore, all examples and conditional language recited herein are principally intended to aid the reader in understanding the principles of the invention and the concepts contributed by the inventors to furthering the art, and are to be construed as being without limitation to such specifically recited examples and conditions. Moreover, all statements herein reciting principles, aspects, and embodiments of the invention as well as specific examples thereof, are intended to encompass both structural and functional equivalents thereof. Additionally, it is intended that such equivalents include both currently known

equivalents and equivalents developed in the future, i.e., any elements developed that perform the same function, regardless of structure. The scope of the present invention, therefore, is not intended to be limited to the exemplary embodiments shown and described herein. Rather, the scope and spirit of present invention is embodied by the appended claims.

CLAIMS

That which is claimed is:

1. A device for stabilizing at least one spinal motion segment comprising a first vertebra having a first spinous process and a second vertebra having a second spinous process, the device comprising:
 - an undeployed configuration having an axial dimension and a radial dimension substantially transverse to the axial dimension; and
 - a deployed configuration having an axial dimension and a radial dimension substantially transverse to the axial dimension;wherein the radial dimension of the undeployed configuration is less than the radial dimension in the deployed configuration.
2. The device of claim 1, wherein the axial dimension of the undeployed configuration is greater than the axial dimension in the deployed configuration.
3. The interspinous device of claim 1, wherein the radial dimension is defined at least in part by a plurality of radially expanding members.
4. The device of claim 3, wherein the radially expanding members comprise deformable struts.
5. The device of claim 3, wherein the radially expanding members comprise linkages.
6. The device of claim 3, comprising a first bracket extending between a first pair of the radially expandable members and a second bracket extending between a second pair of the radially expandable members.
7. The device of claim 6, wherein the brackets each comprise a substantially rigid central portion and two substantially flexible lateral portions.
8. The device of claim 1, wherein the device in the undeployed has a cylindrical shape.

9. The device of claim 1, wherein the device in the deployed has a "X" shape.
10. A system for stabilizing at least one spinal motion segment comprising a first vertebra having a first spinous process and a second vertebra having a second spinous process and an interspinous space defined between the first and second spinous processes, the system comprising:
 - the device of claim 1; and
 - a device for delivering the device in the undeployed configuration within the interspinous processes and for radially expanding the device from the undeployed configuration to the deployed configuration.
11. The system of claim 10, wherein the device is configured for delivery by the delivery device through a midline incision.
12. An interspinous device for stabilizing at least one spinal motion segment comprising a first vertebra having a first spinous process and a second vertebra having a second spinous process, the device comprising:
 - an axial dimension and a radial dimension substantially transverse to the axial dimension, wherein the axial dimension is greater when the device is in an undeployed configuration and the radially dimension is greater when the device is in a deployed configuration.
13. The interspinous device of claim 12, wherein the axial dimension is defined by a central member and the radial dimension is defined at least in part by a plurality of radially expandable members.
14. The interspinous device of claim 13, comprising a first strap extending between a first pair of the radially expandable members and a second strap extending between a second pair of the radially expandable members.
15. The interspinous device of claim 13, wherein the radially expandable members comprise linkages.

16. The interspinous device of claim 13, wherein the radially expandable members comprise deformable struts.

17. The interspinous device of claim 13, wherein the radially expandable members comprise a compressible material.

18. A system for stabilizing at least one spinal motion segment comprising a first vertebra having a first spinous process and a second vertebra having a second spinous process and an interspinous space defined between the first and second spinous processes, the system comprising:

the interspinous device of claim 12; and

a device for delivering the interspinous device in the undeployed state within the interspinous processes and for axially reducing and radially expanding the device from the undeployed state to the deployed state.

19. The system of claim 18, wherein the interspinous device is configured for delivery by the delivery device through a midline incision.

20. An interspinous device for stabilizing at least one spinal motion segment comprising a first vertebra having a first spinous process and a second vertebra having a second spinous process, the device comprising:

a tubular member having a length and a diameter and being deployable from a first configuration to a second configuration, wherein one of the length and the diameter of the tubular member in the first configuration is changed when the tubular member is in the second configuration.

21. The device of claim 20 wherein the length of the tubular member in the first configuration is greater than the length of the tubular member in the second configuration.

22. The device of claim 20 wherein the diameter of the tubular member in the second configuration is greater than the diameter of the tubular member in the first configuration.

23. The device of claim 20 further comprising a retaining member circumferentially positioned about a portion of the length of the tubular member, wherein the diameter of the retained portion of the tubular member is less than the diameter of the unretained portion of the tubular member when the tubular member is in the second configuration.

24. The device of claim 23, wherein the retaining member is positioned about a central portion of the tubular member.

25. The device of claim 20, further comprising a core member positionable within the tubular member; and first and second hubs configured for coupling with a first end of the core member and a second end of the core member, respectively.

26. The device of claim 25, wherein the at least one of the hubs is configured to translate axially over the core member.

27. The device of claim 20, wherein the tubular member comprises a polymer material.

28. The device of claim 20, wherein the retaining member comprises a braided or mesh material.

29. A system for stabilizing at least one spinal motion segment comprising a first vertebra having a first spinous process and a second vertebra having a second spinous process, the system comprising:

the interspinous device of claim 20; and

a device for delivering the interspinous device when in the first configuration between the first and second spinous process and for deploying the interspinous device in the second configuration.

30. The system of claim 29 wherein the delivery device comprises:

an elongated shaft having a detachable distal end configured for insertion into the tubular member of the interspinous device; and

a handle mechanism for moving the elongated shaft wherein the movement causes the tubular member to be deployed from the first configuration to the second configuration.

31. An interspinous device for stabilizing at least one spinal motion segment comprising a first vertebra having a first spinous process and a second vertebra having a second spinous process, the device comprising:

an expandable member having an unexpanded configuration and an expanded configuration, wherein the expandable member in the unexpanded configuration has a size configured for positioning between the first and second spinous process and in the expanded configuration provides distraction of the first and second spinous processes, wherein the expandable member is mechanically actuatable from the unexpanded configuration to the expanded configuration.

32. The device of claim 31, wherein the expandable member comprises a plurality of parallel struts.

33. The device of claim 32, wherein the plurality of struts are affixed between two opposing hubs.

34. The device of claim 31, wherein the expandable member comprises a coiled band.

35. The device of claim 34, wherein the coiled band comprises inner and outer ends which are connectable to each other.

36. The device of claim 31, wherein the expandable member comprises a plurality of nested portions.

37. The device of claim 31, wherein the expandable member has a spherical configuration.

38. The device of claim 1, wherein the expandable member has an elliptical configuration.
39. The device of claim 31, wherein the expandable member has a disk configuration.
40. The device of claim 31, wherein the expandable member is self-expanding.
41. A system for stabilizing at least one spinal motion segment comprising a first vertebra having a first spinous process and a second vertebra having a second spinous process, the system comprising:
an expandable member having an unexpanded configuration and an expanded configuration, wherein the expandable member in the unexpanded configuration has a size configured for positioning between the first and second spinous process and in the expanded configuration provides distraction of the first and second spinous processes, wherein the expandable member is mechanically actuatable from the unexpanded configuration to the expanded configuration.; and
means for mechanically actuating the expandable member.
42. The system of claim 41, wherein said mechanical actuation means is a guide wire.

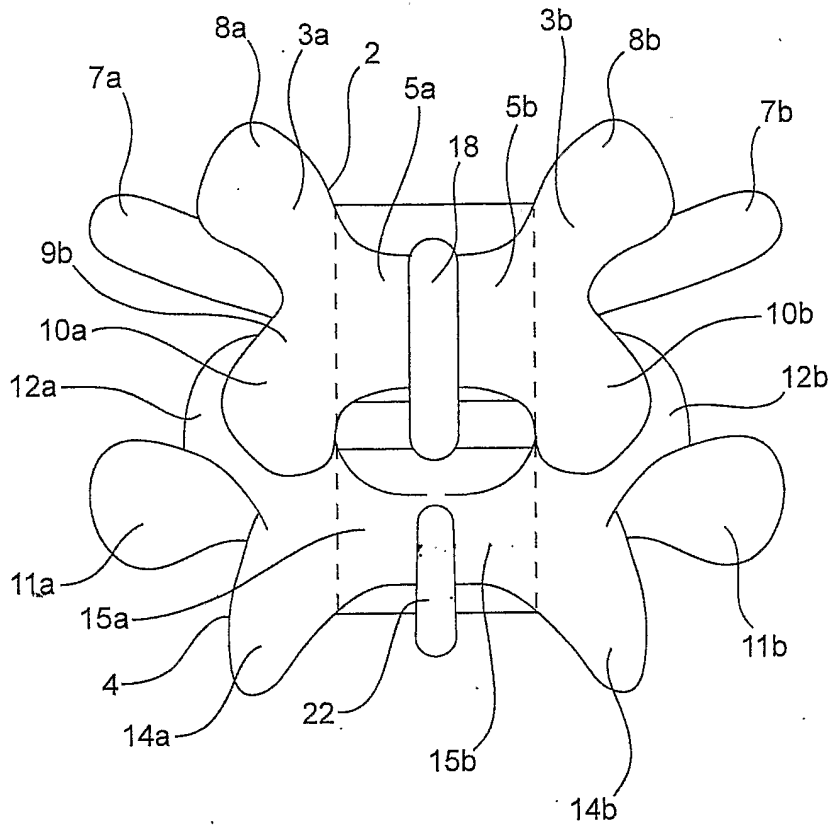

FIG. 1

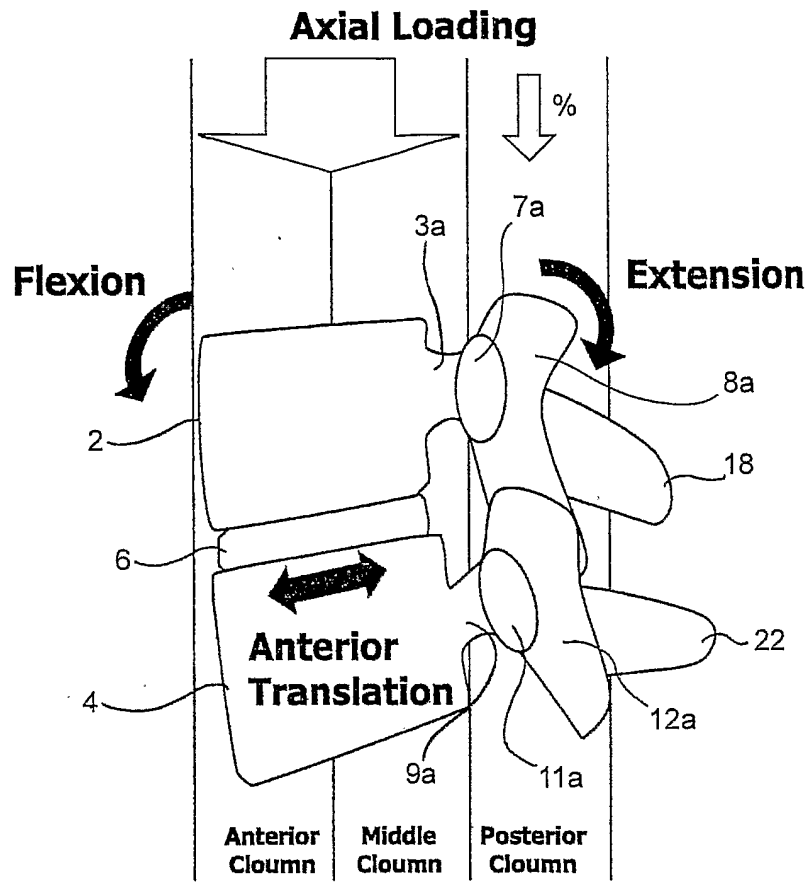

FIG. 2A

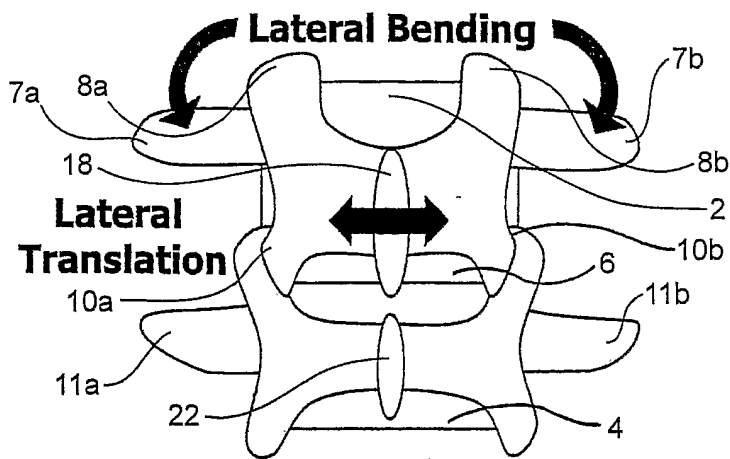

FIG. 2B

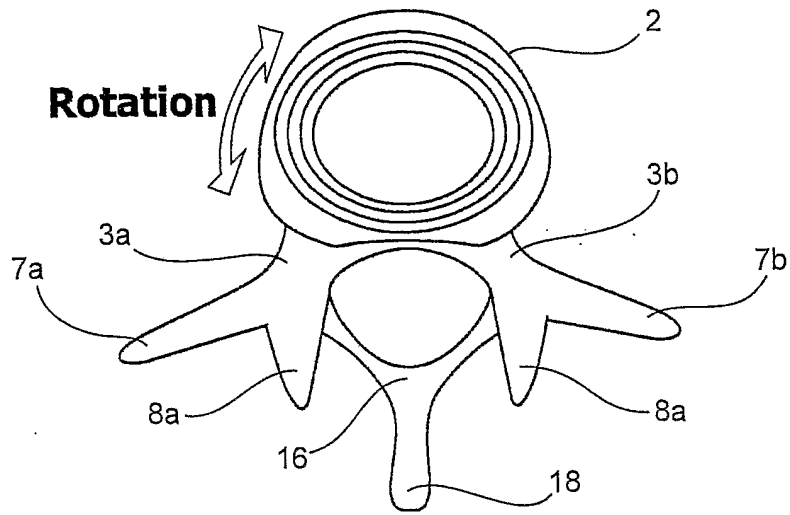
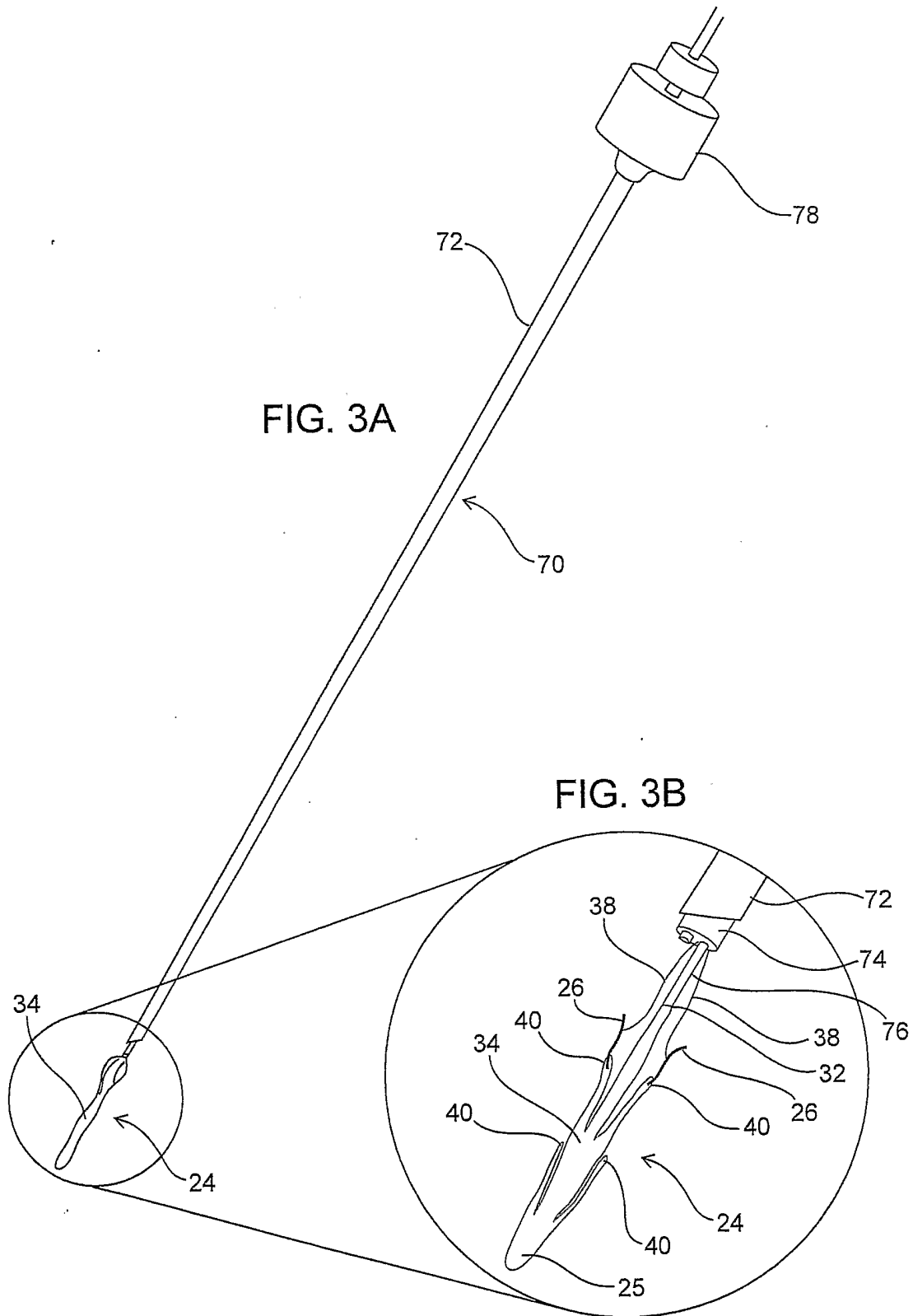

FIG. 2C



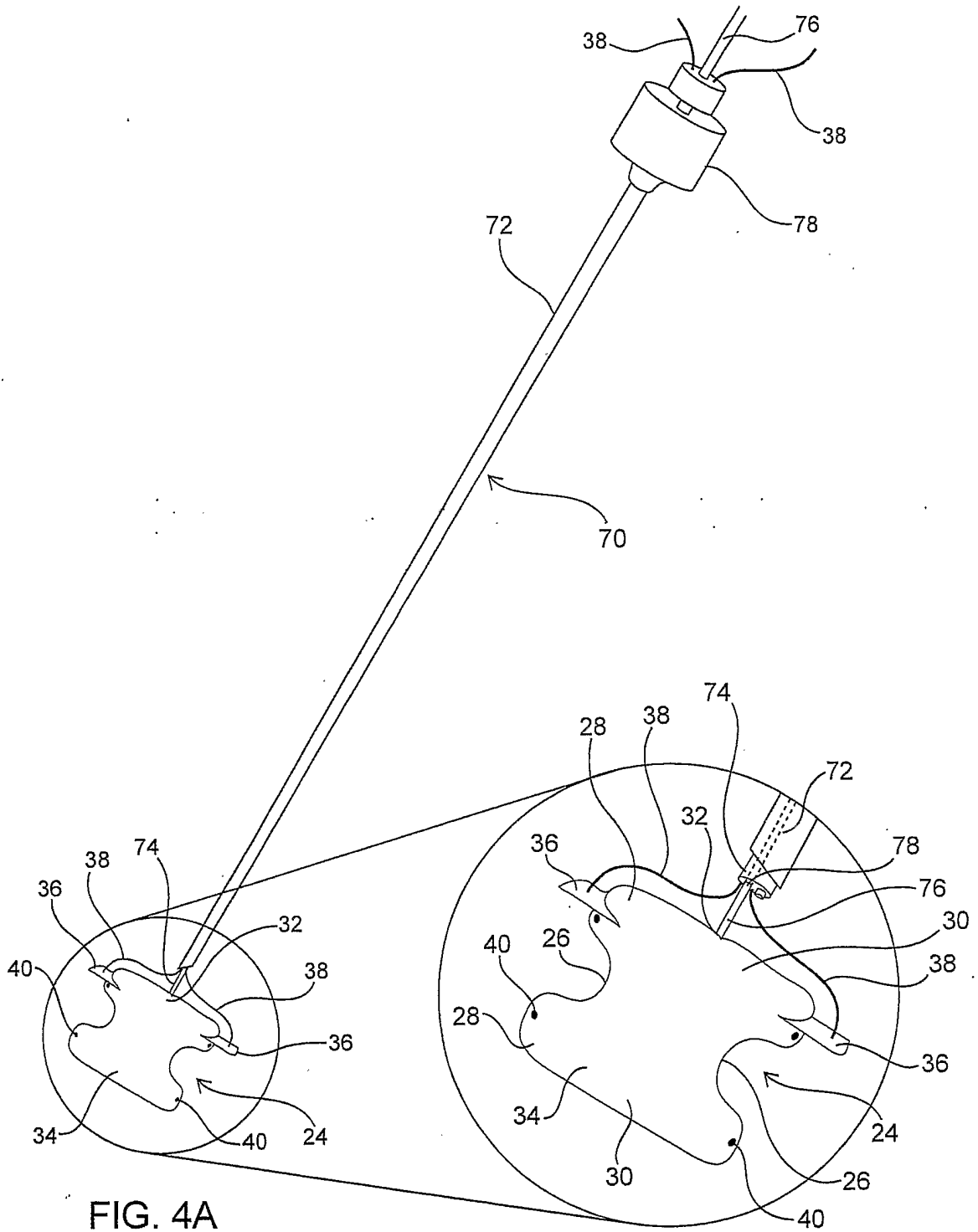
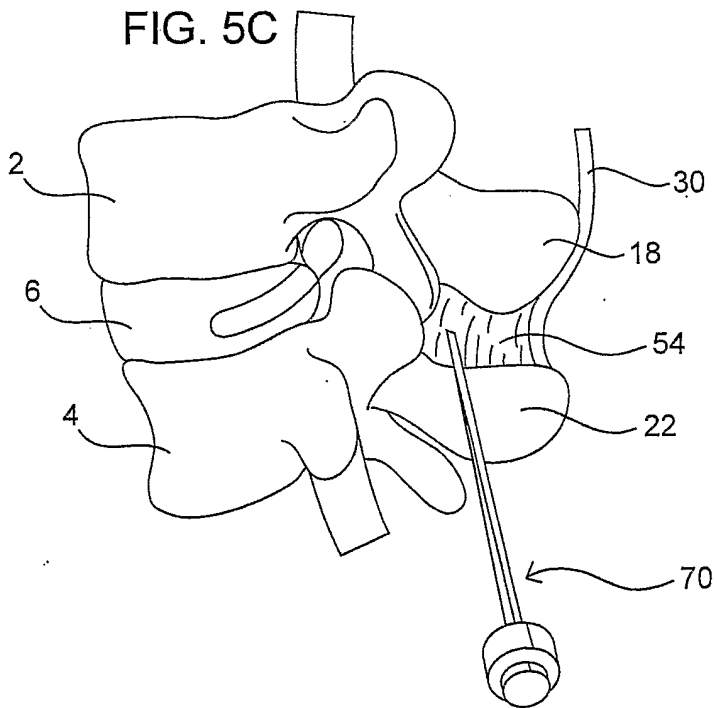
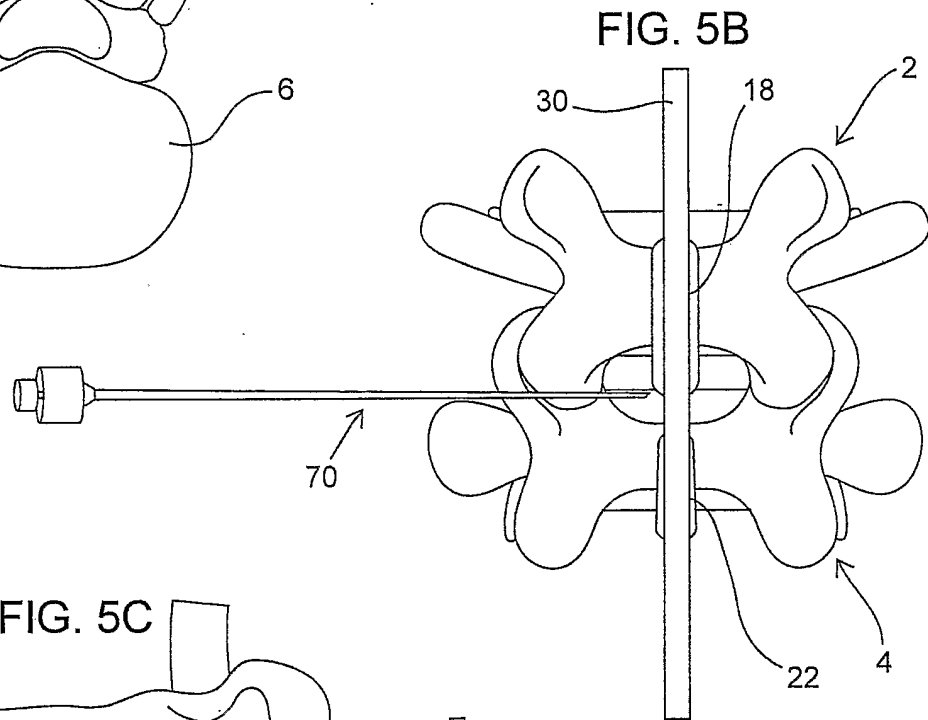
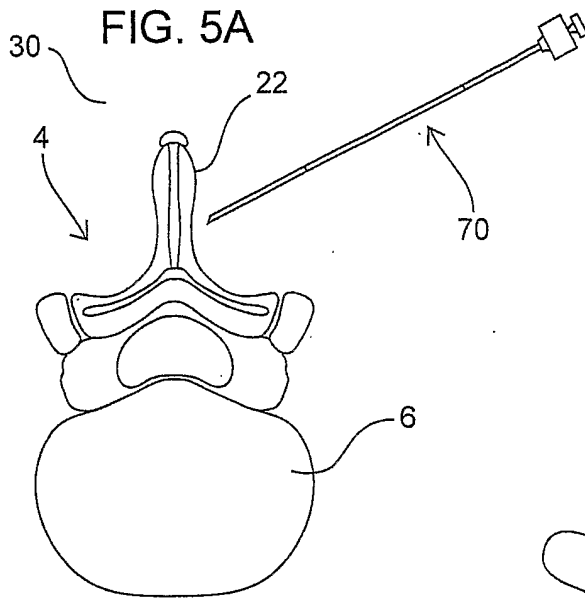

FIG. 4A

FIG. 4B



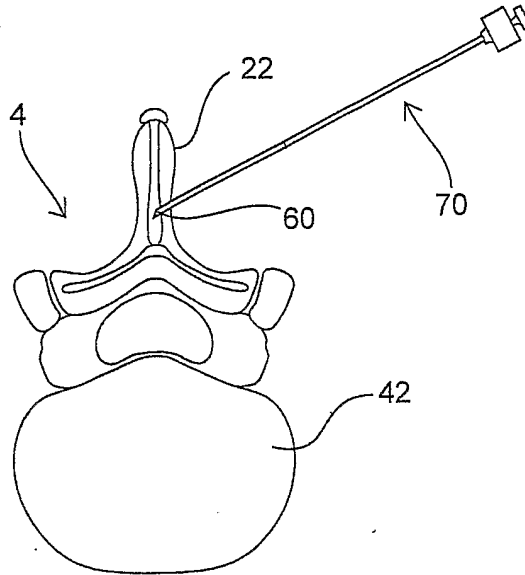

FIG. 6A

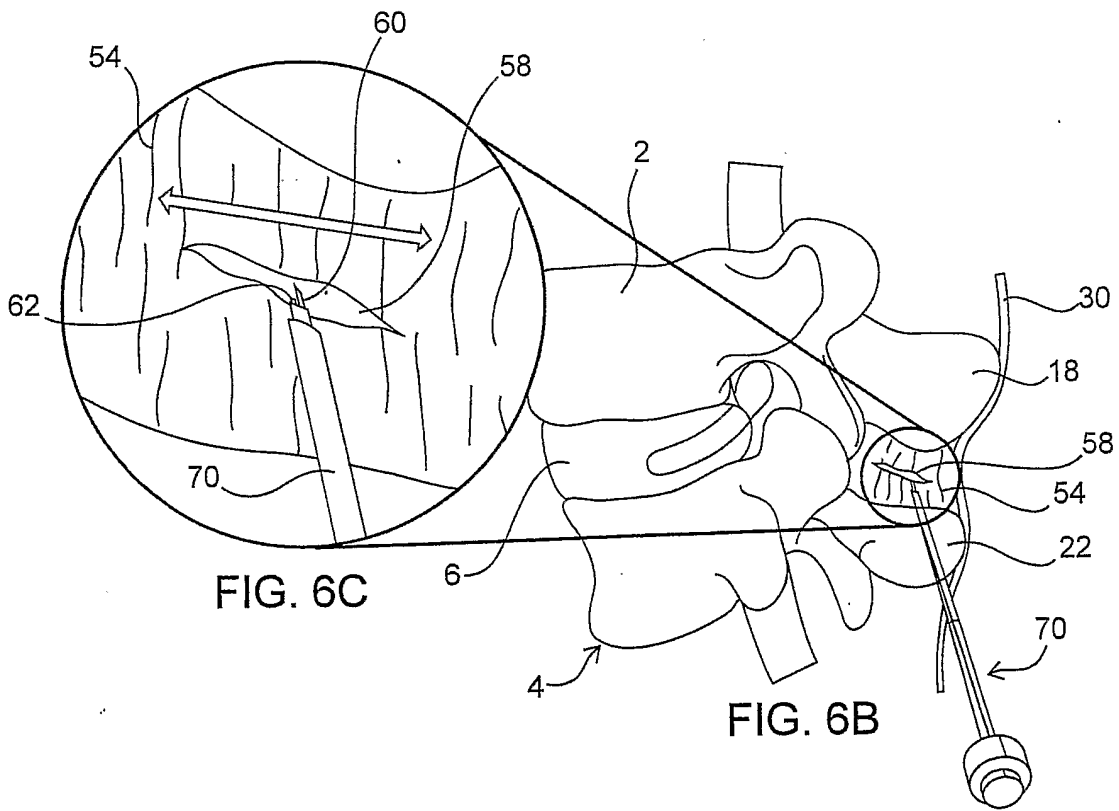

FIG. 6C

FIG. 6B

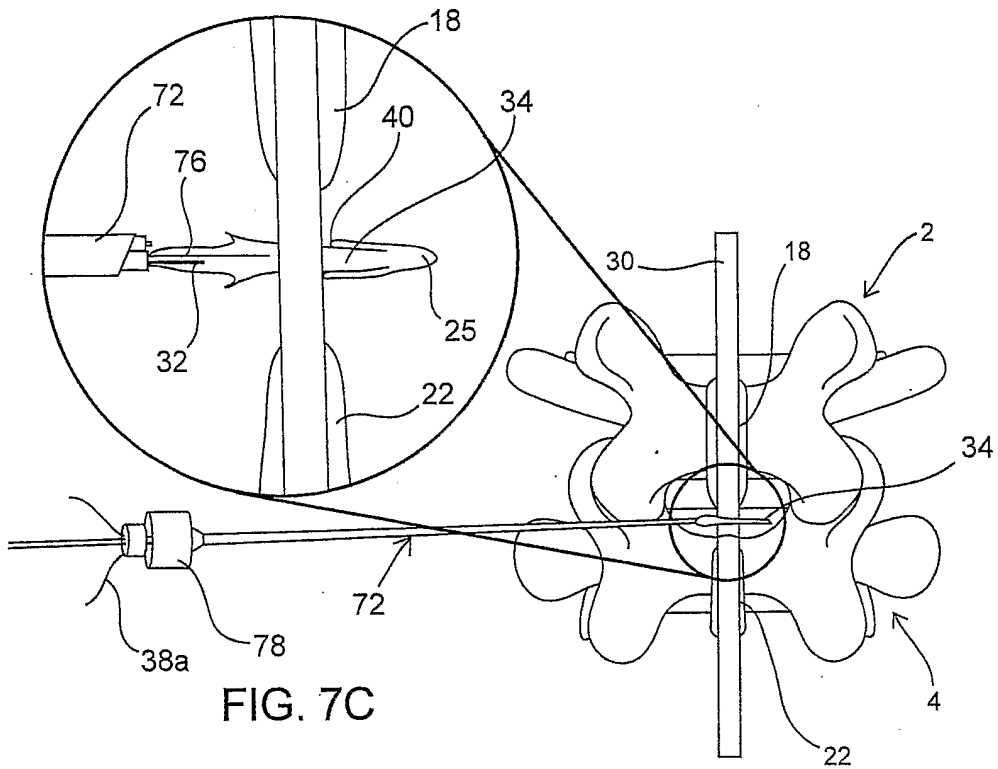

FIG. 7C

FIG. 7A

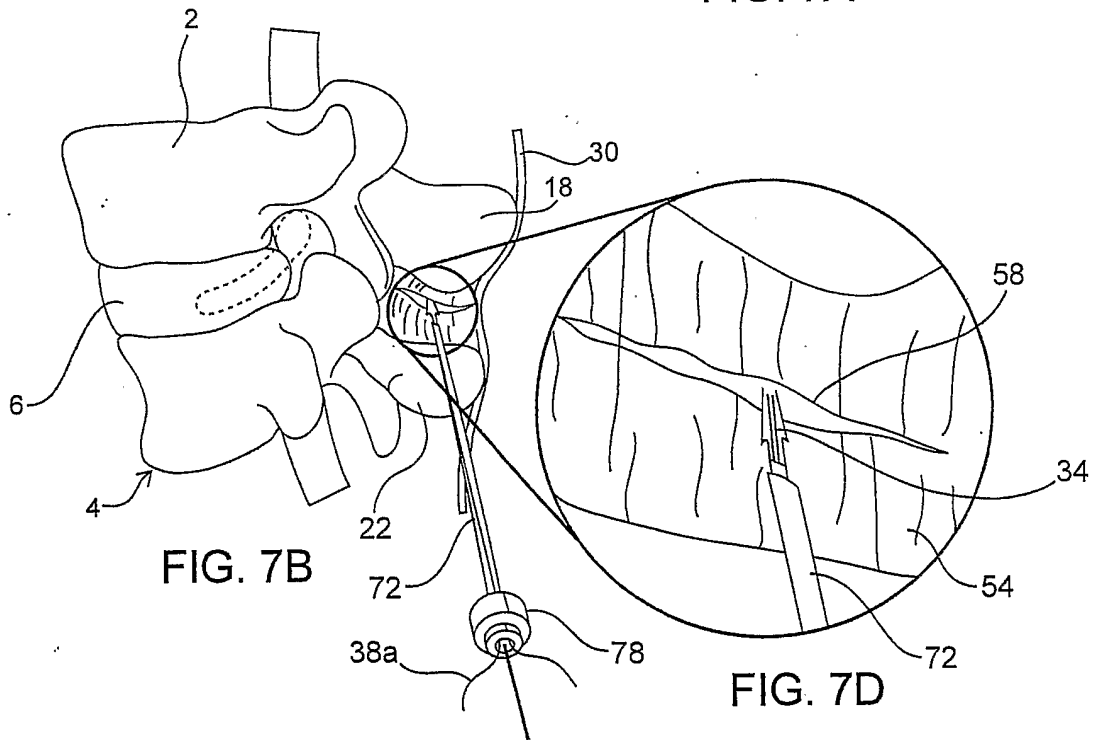
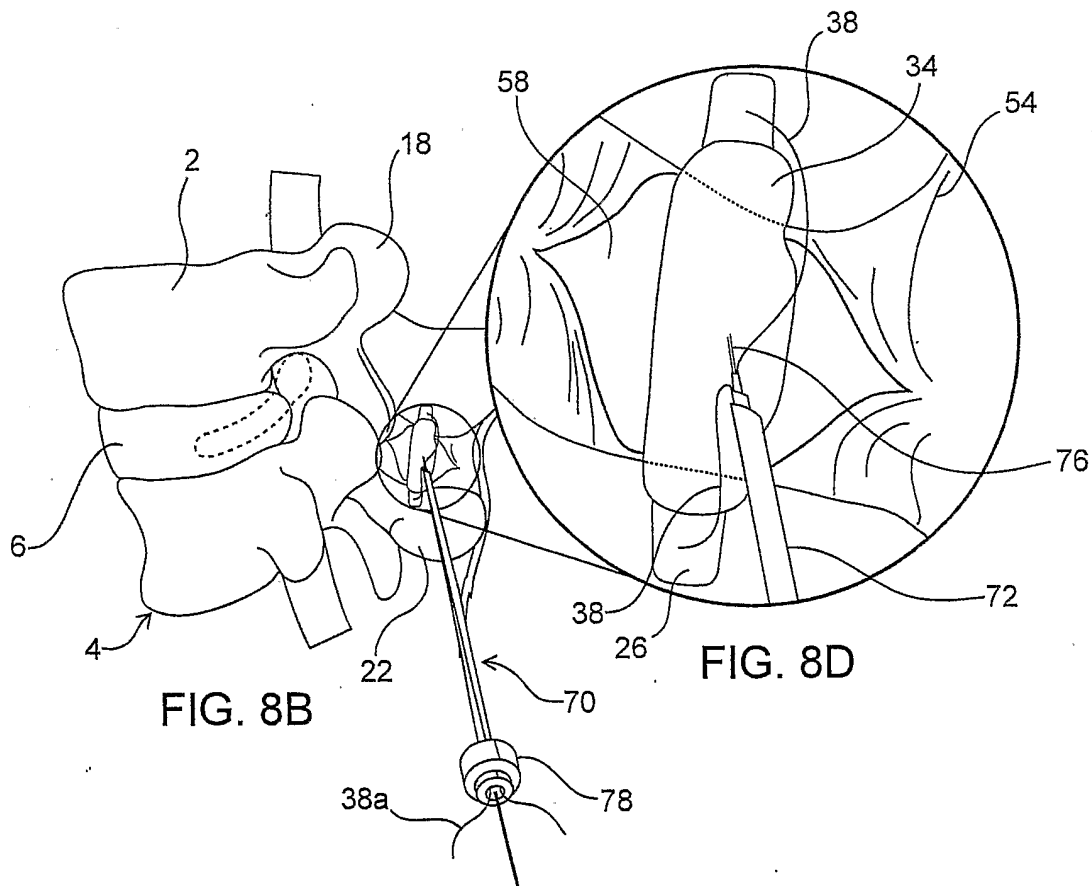
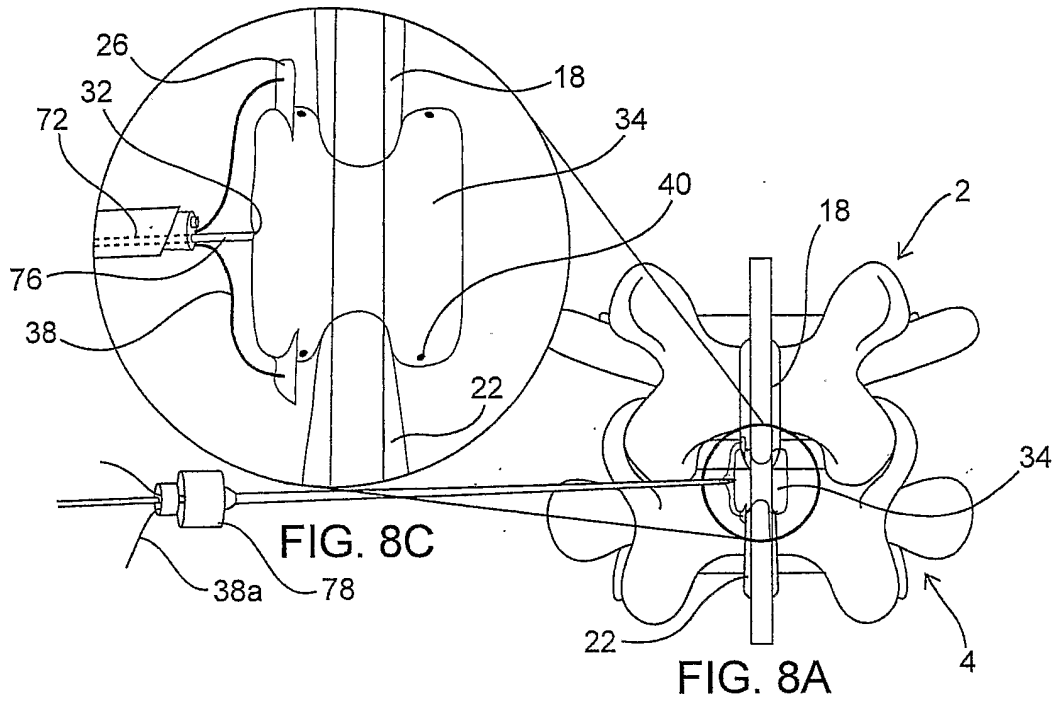

FIG. 7B

FIG. 7D



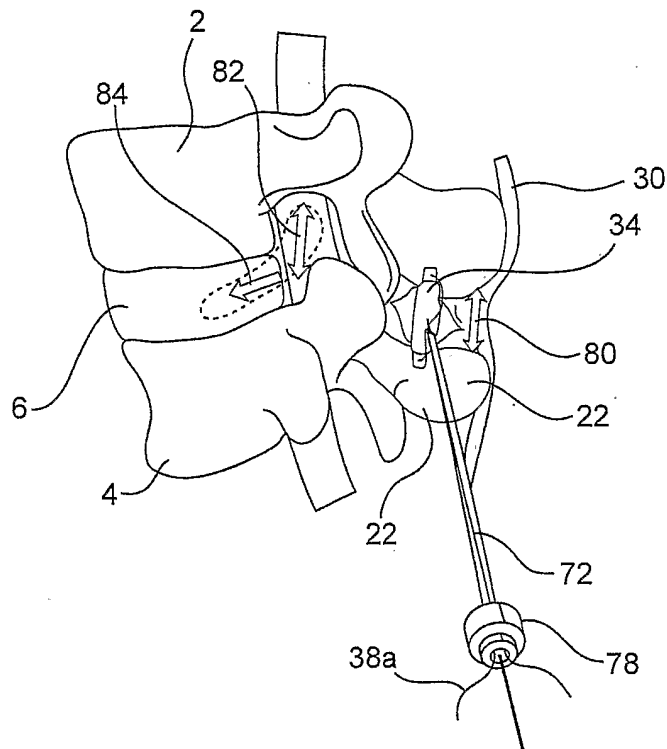

FIG. 9A

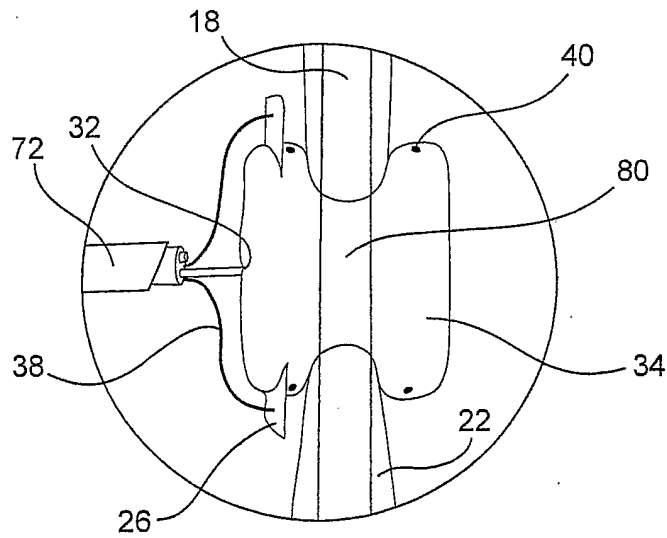
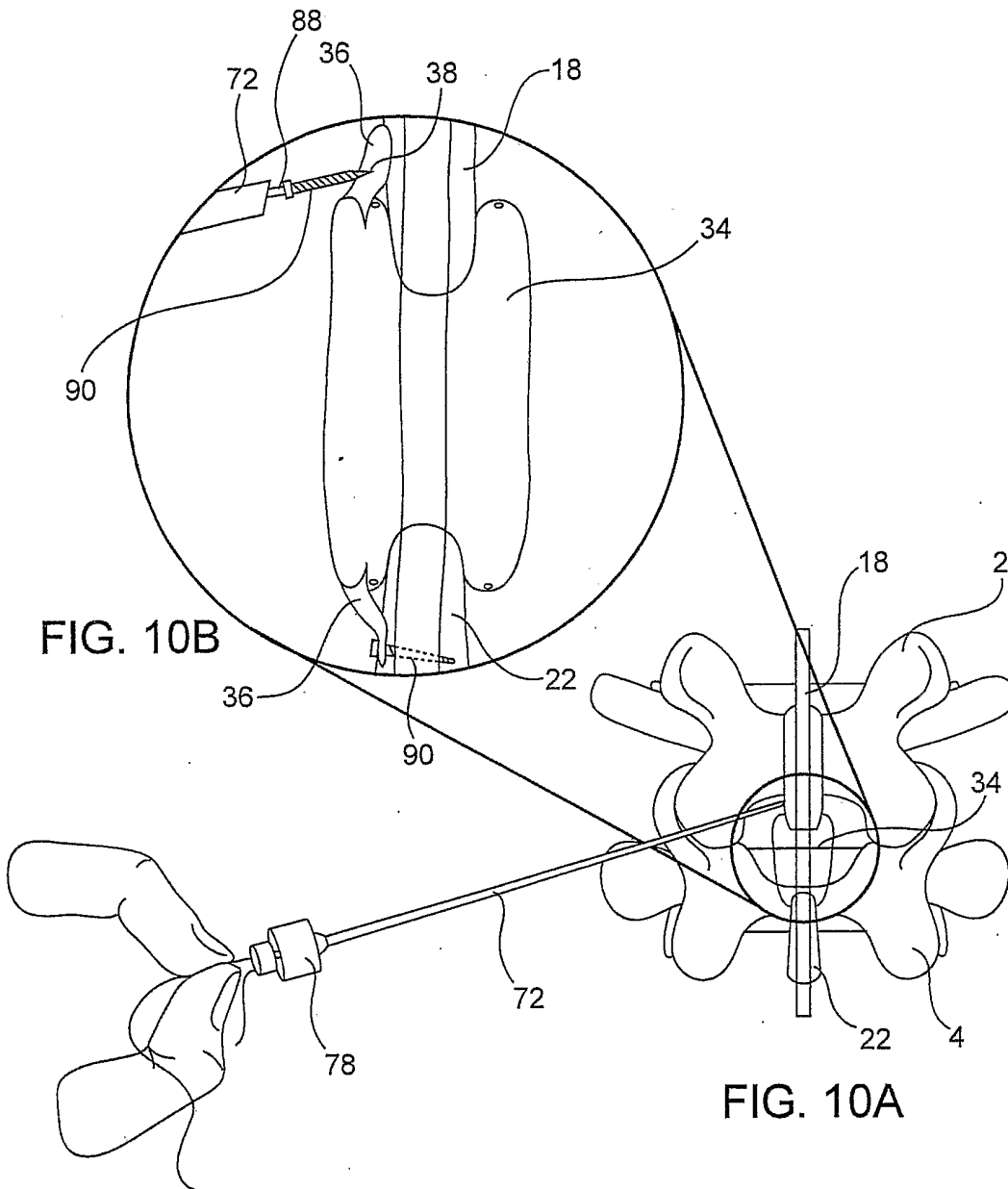

FIG. 9B



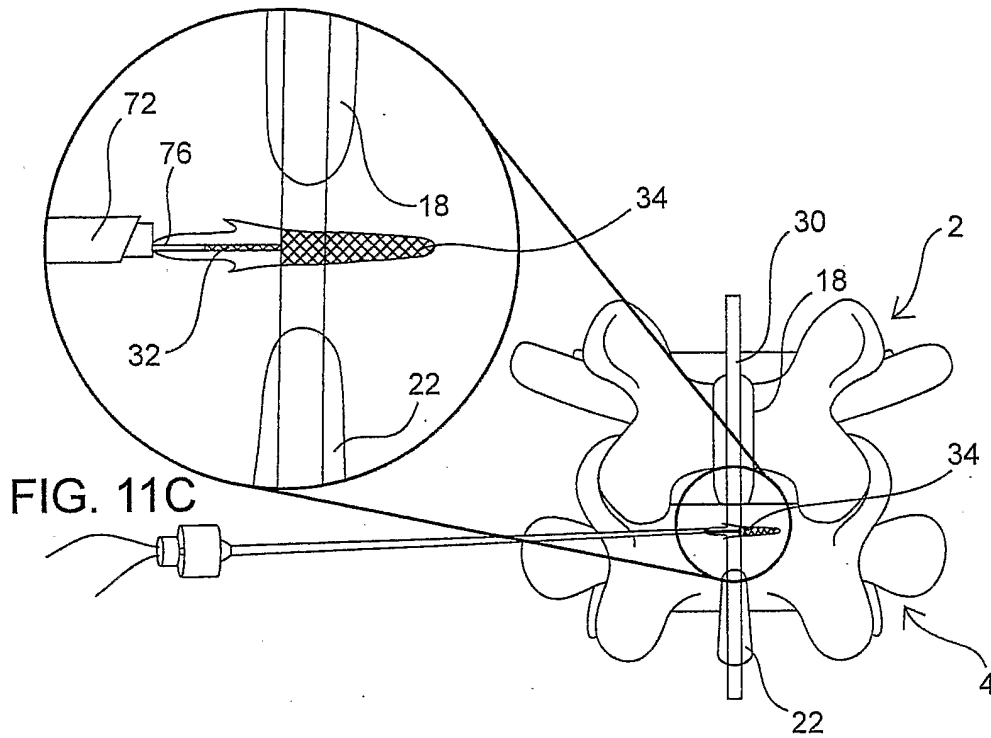

FIG. 11A

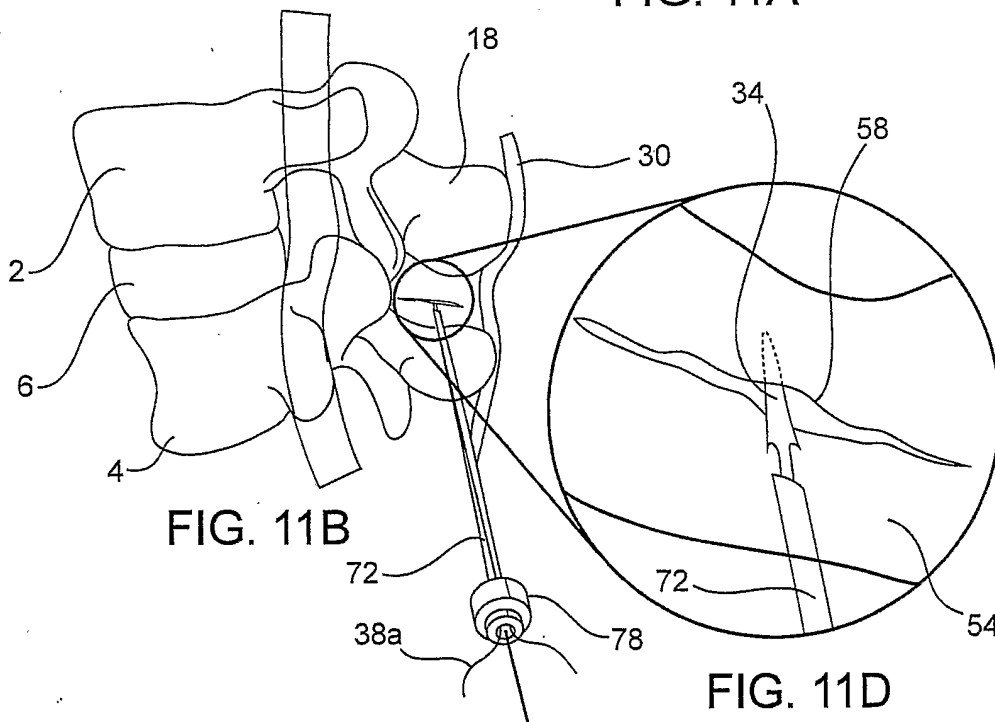
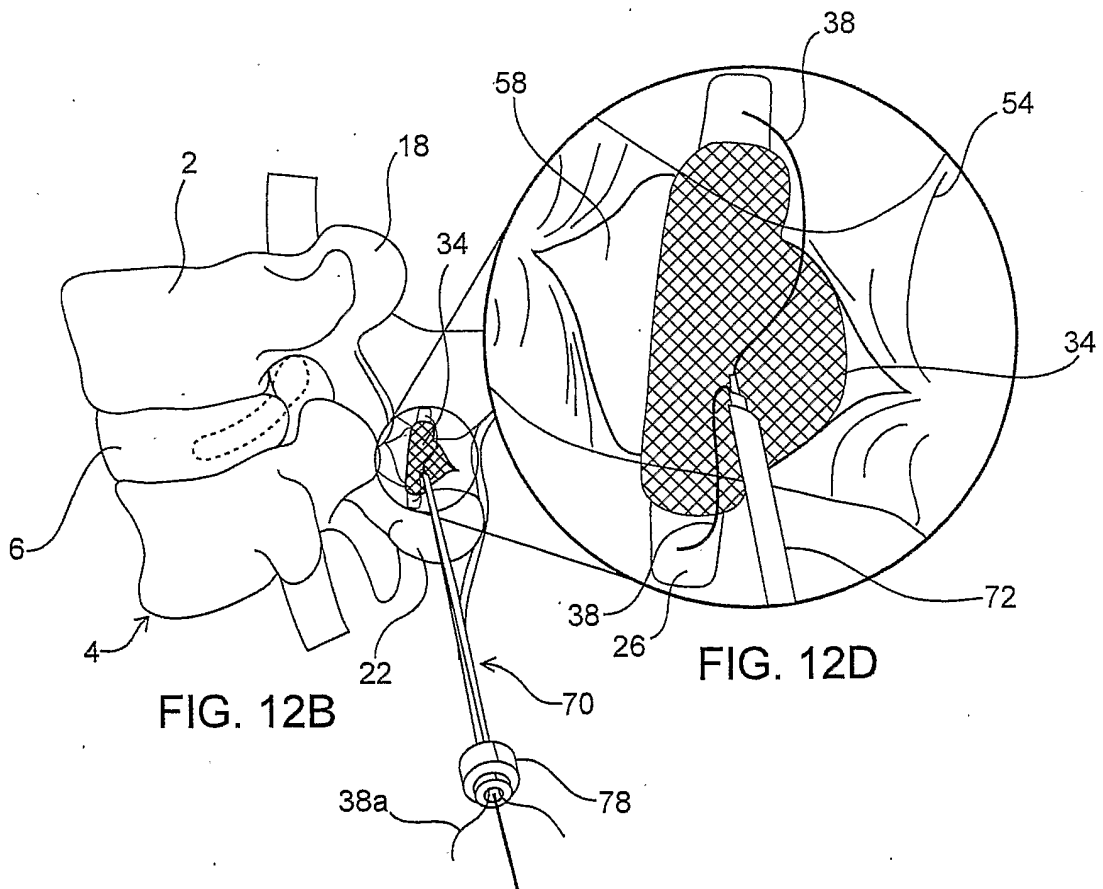
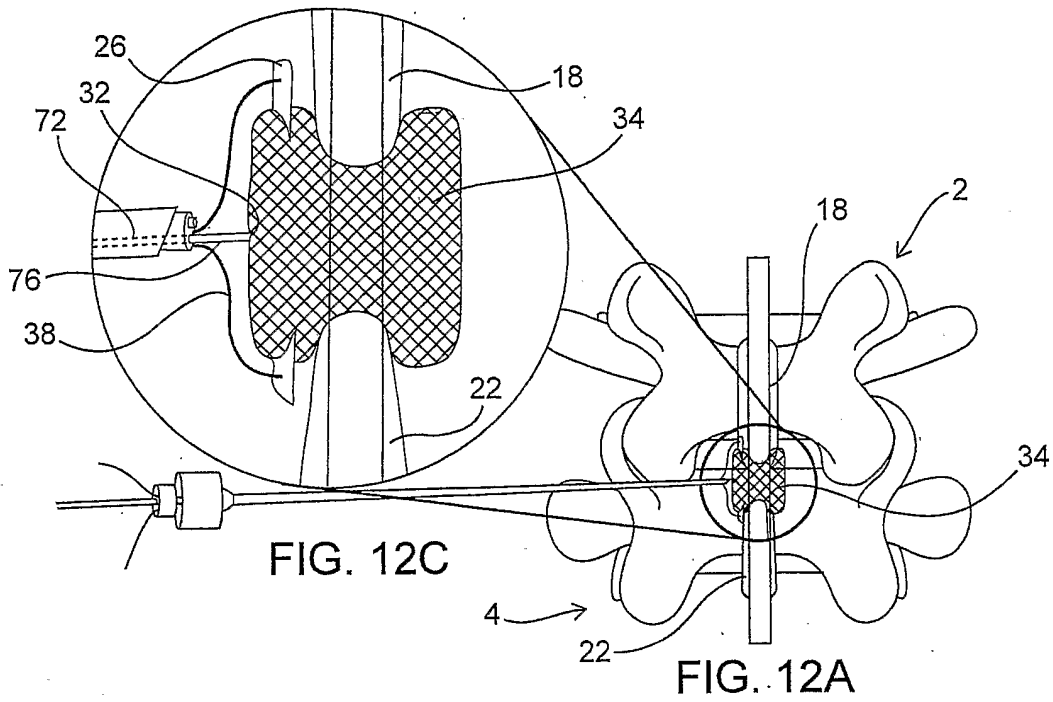
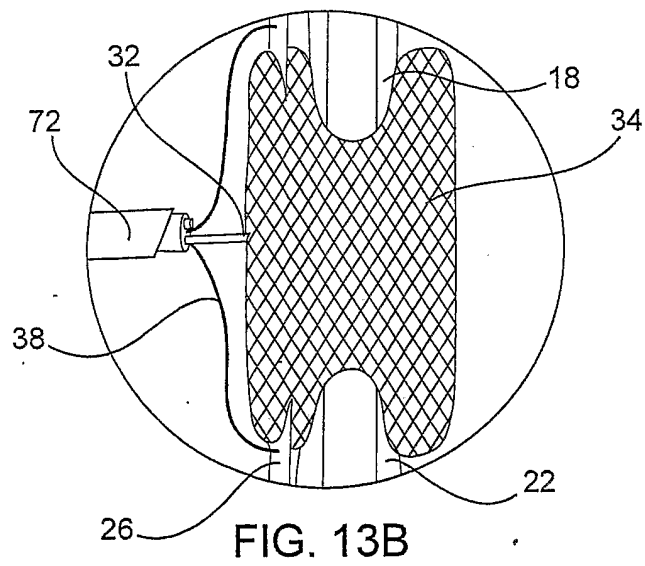
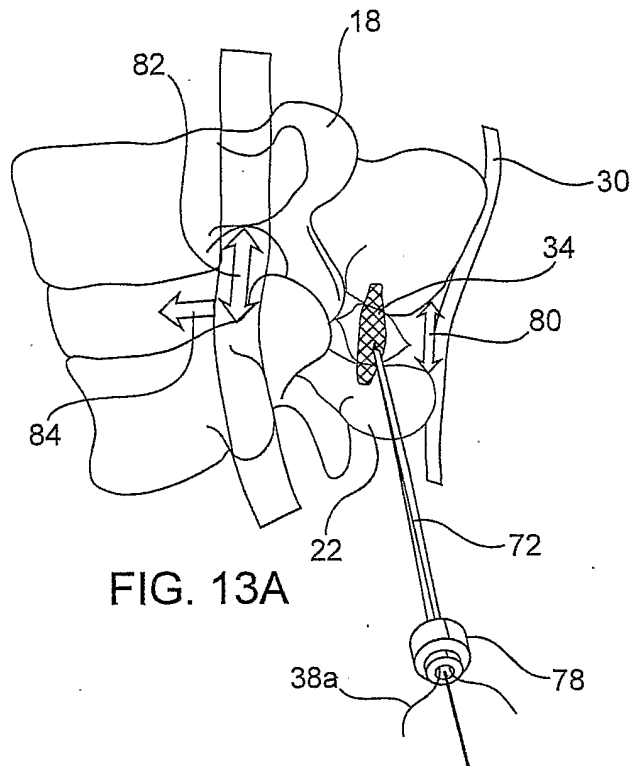
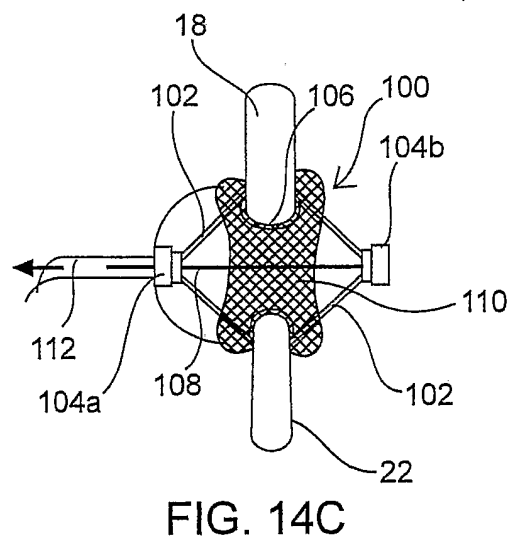
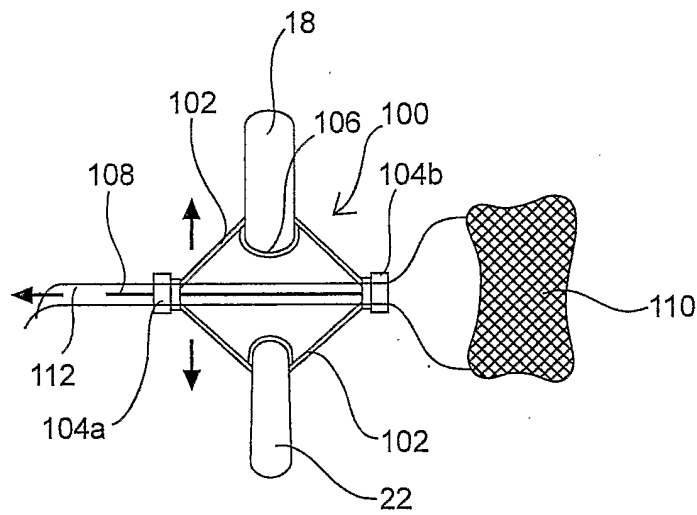
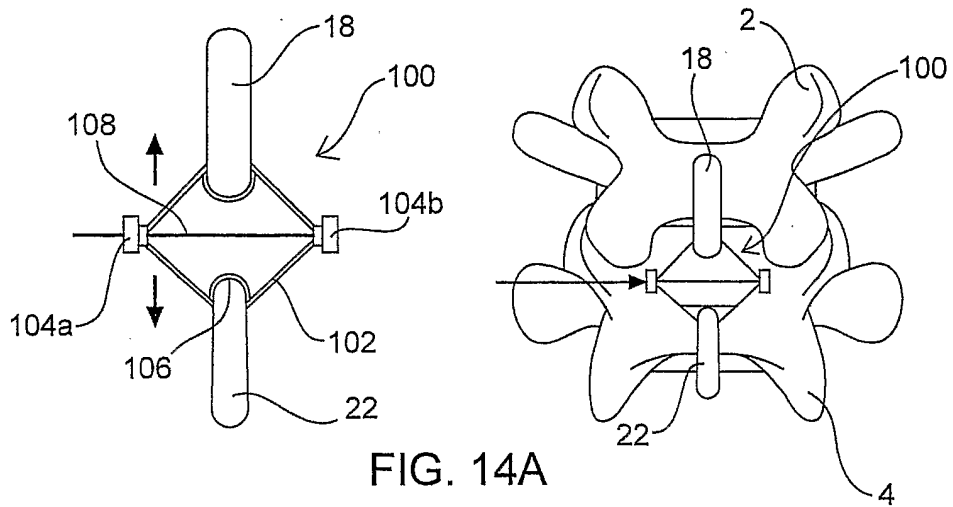

FIG. 11B

FIG. 11D







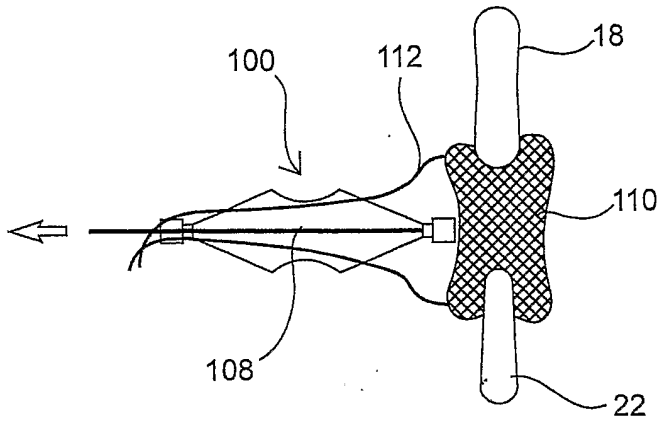

FIG. 14D

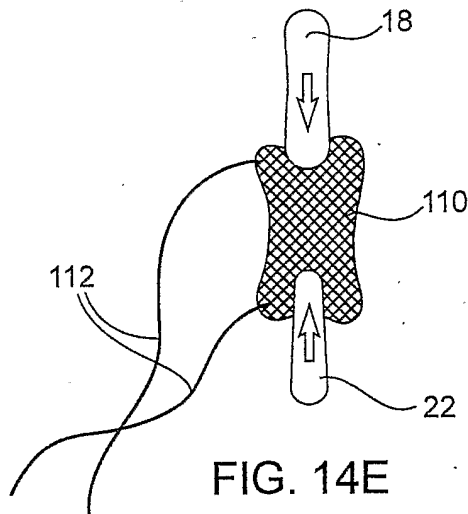

FIG. 14E

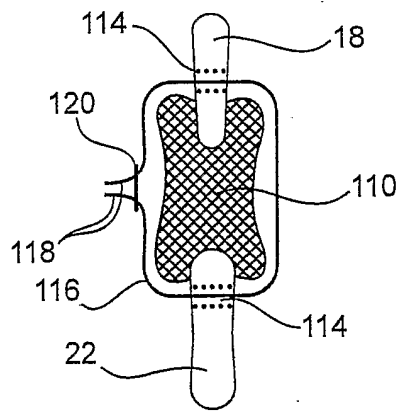

FIG. 14F

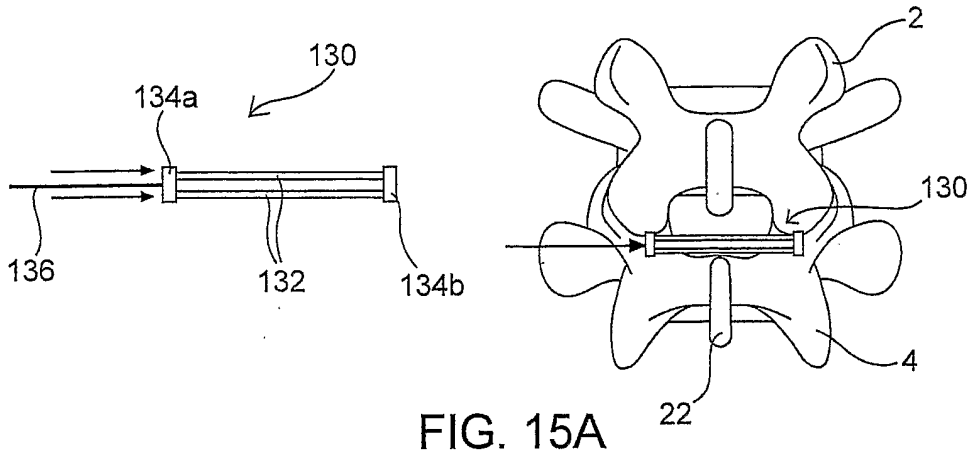

FIG. 15A

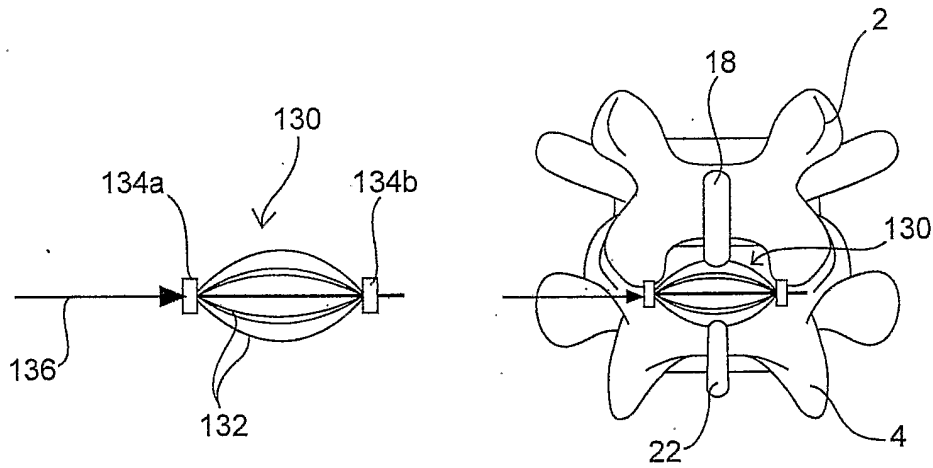

FIG. 15B

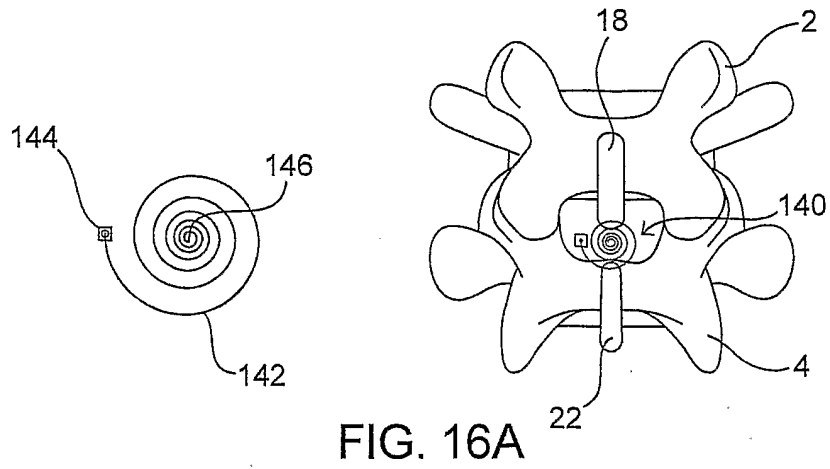

FIG. 16A

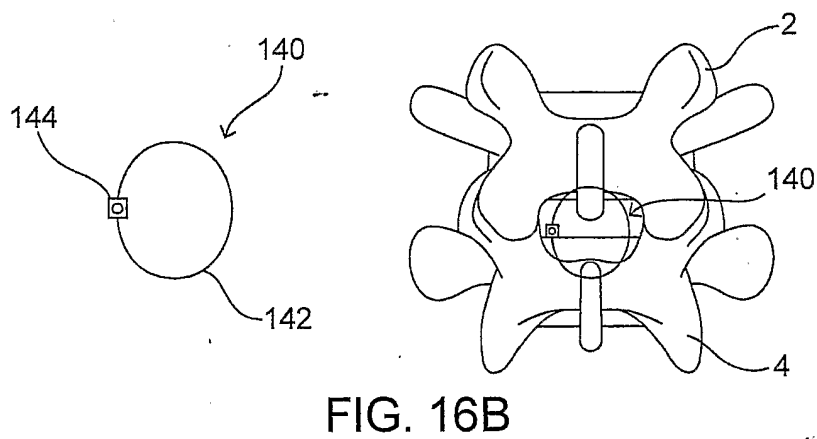

FIG. 16B

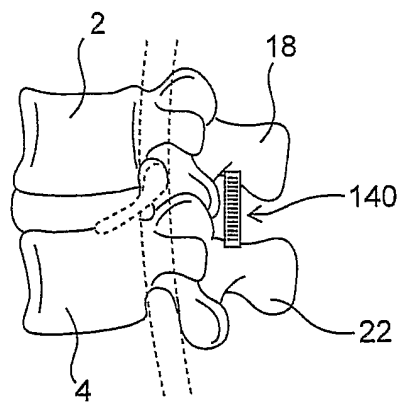

FIG. 16C

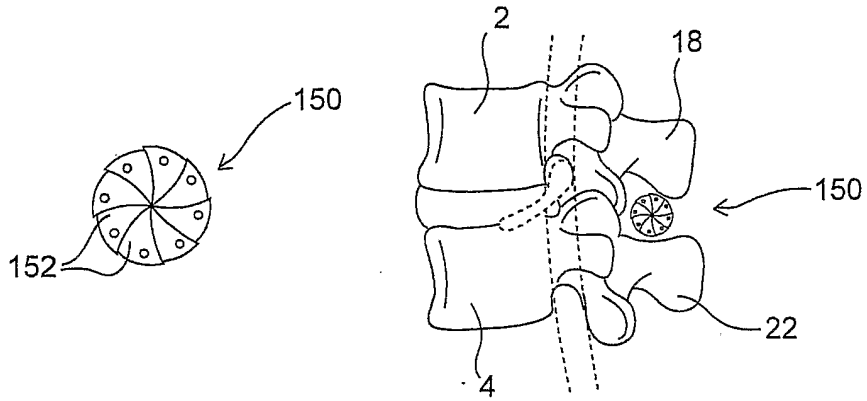

FIG. 17A

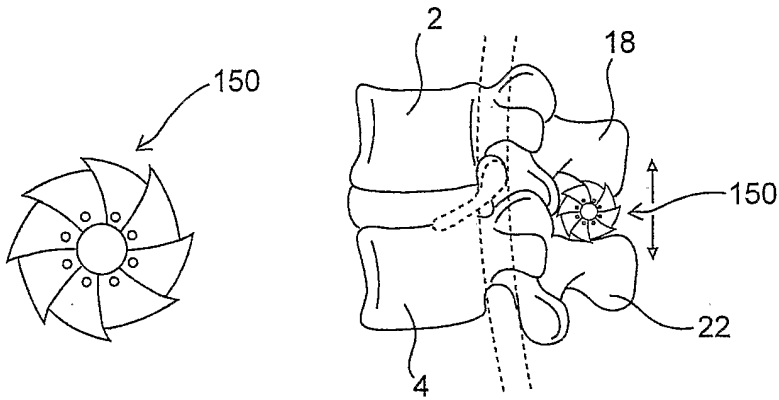

FIG. 17B

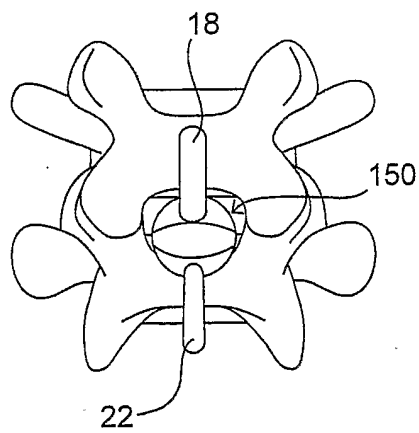

FIG. 17C

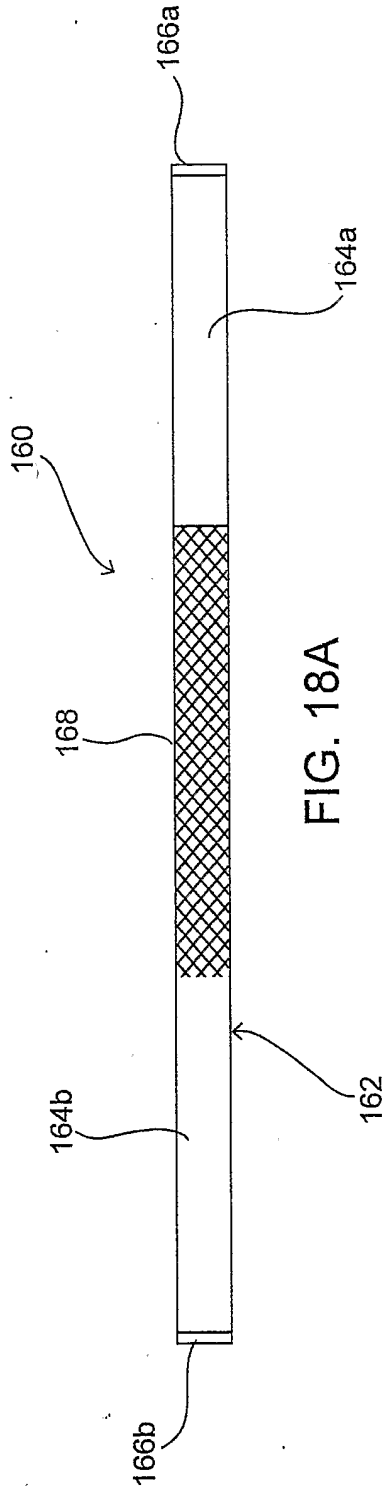

FIG. 18A

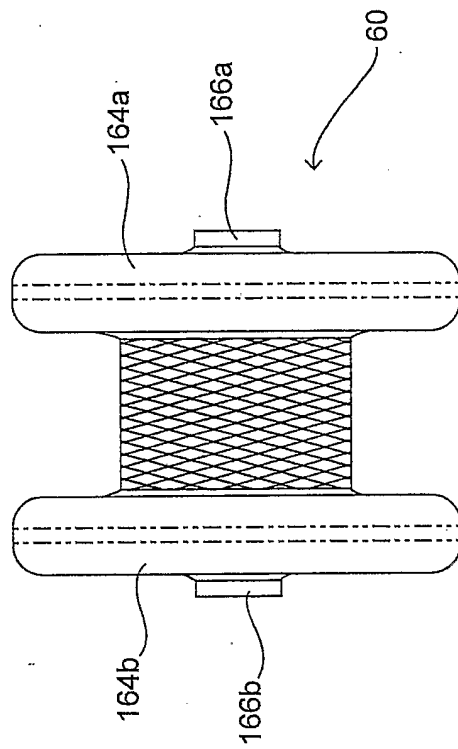
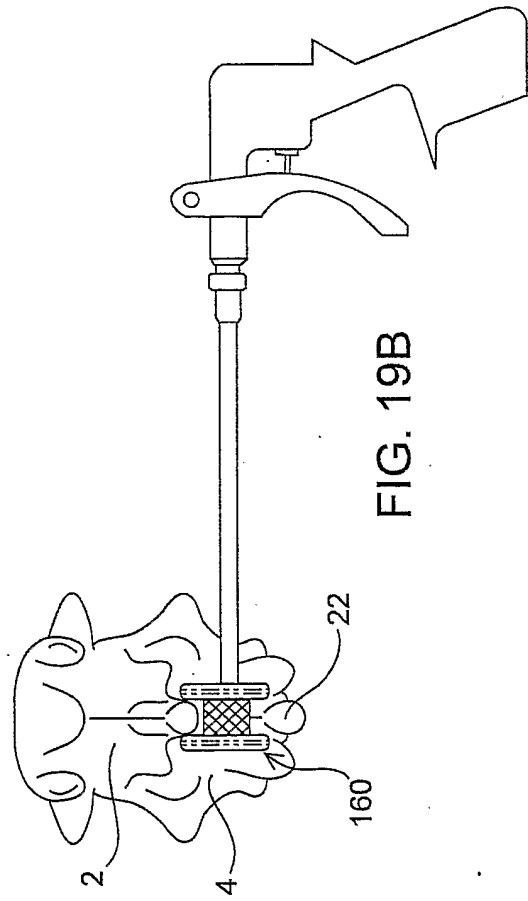
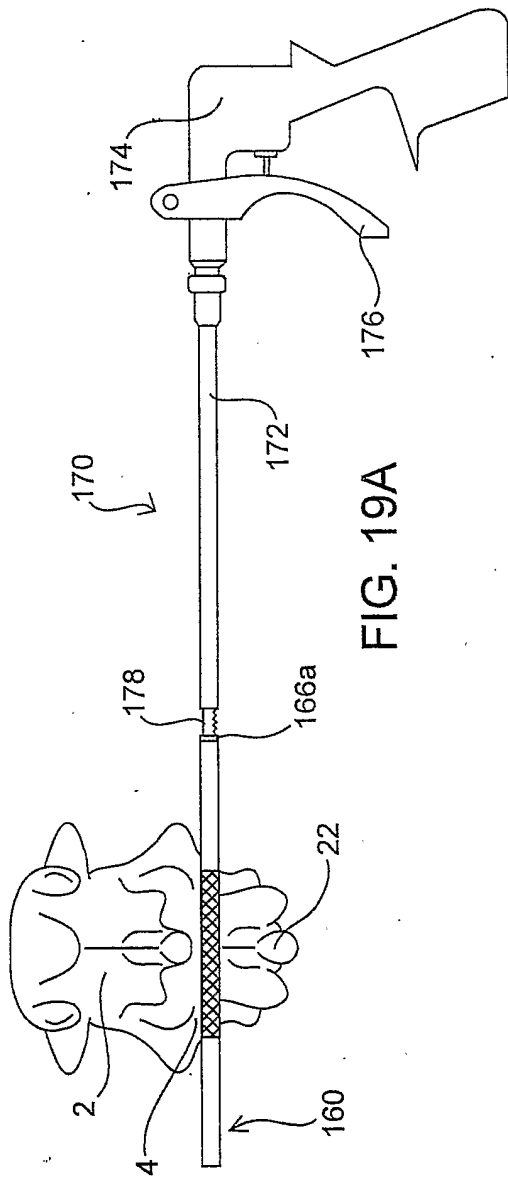
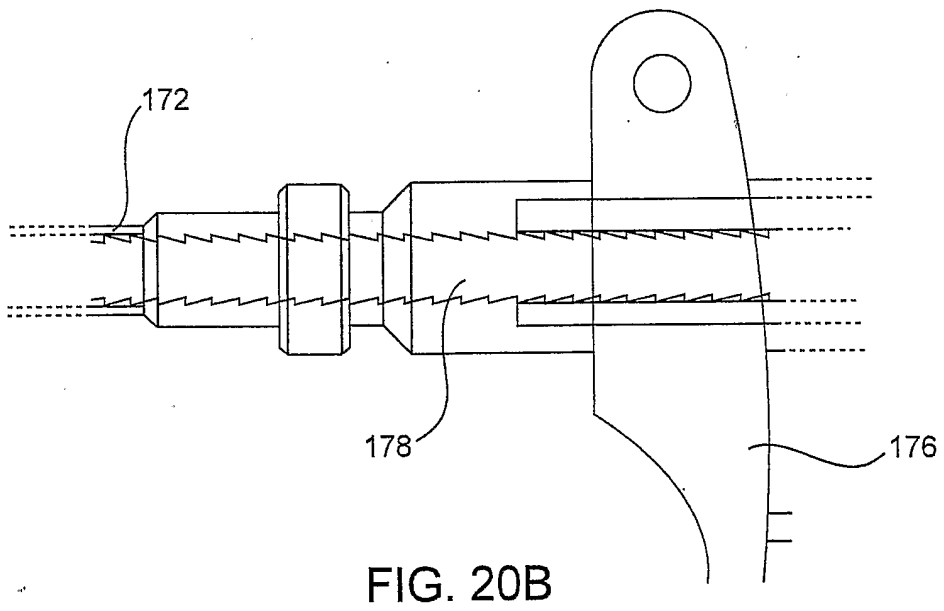
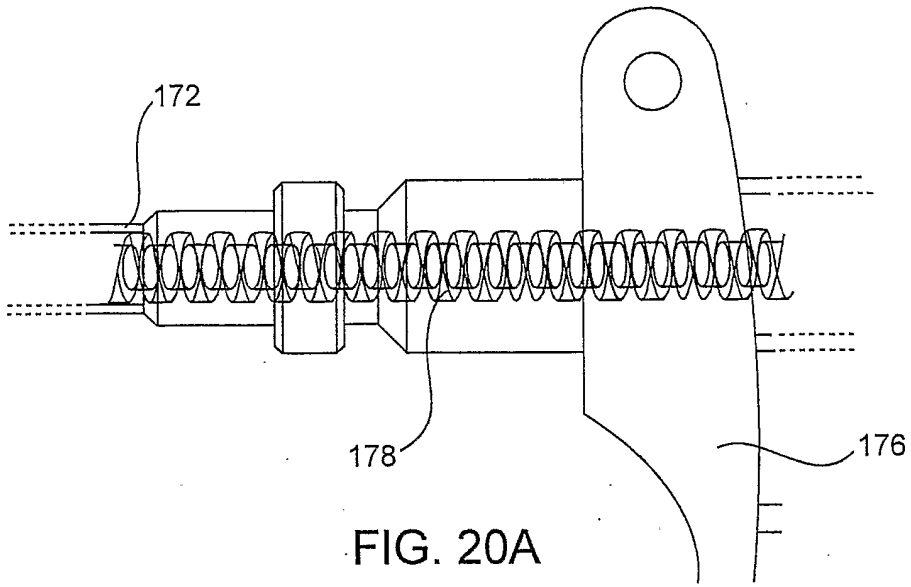

FIG. 18B





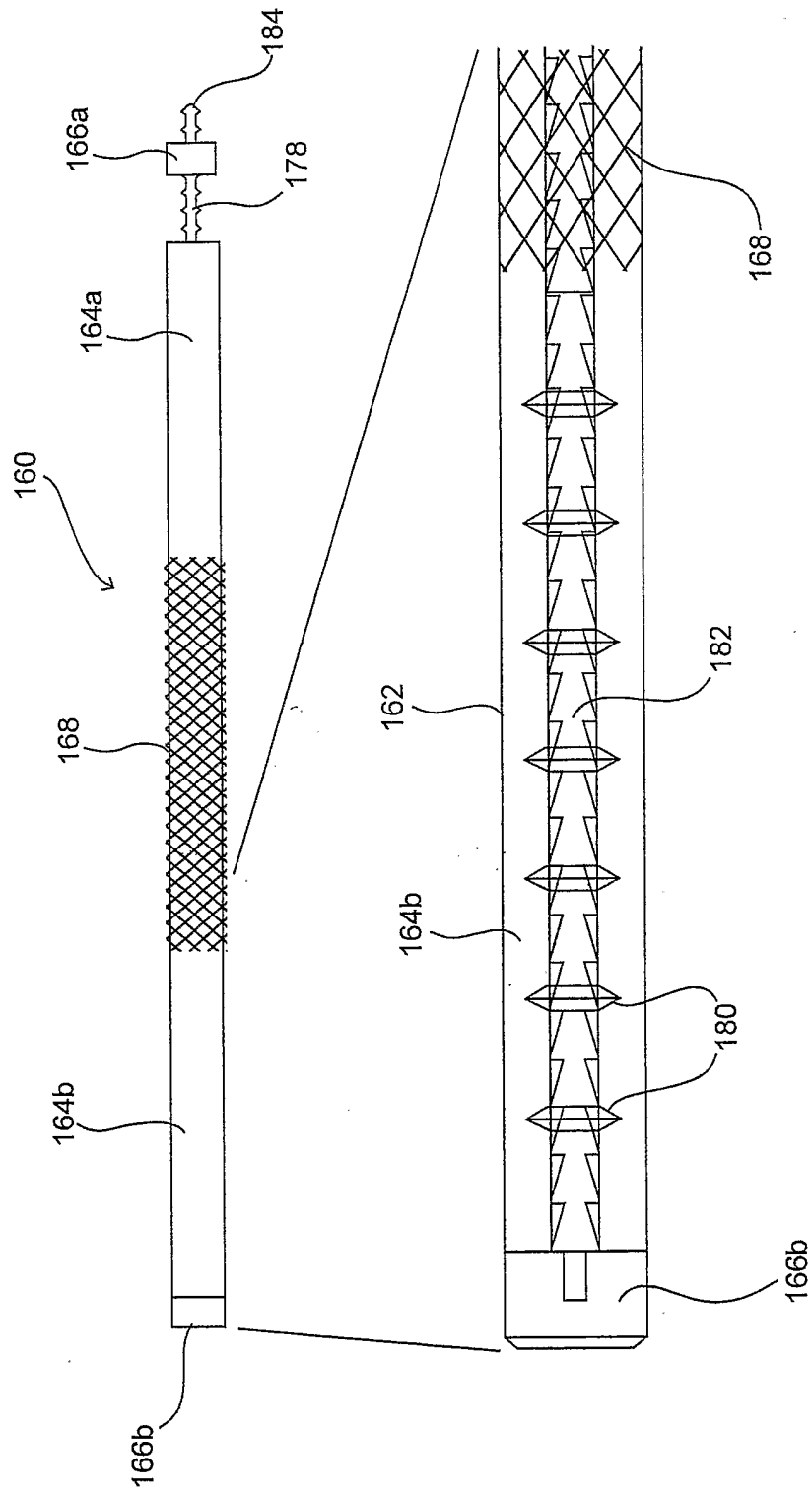
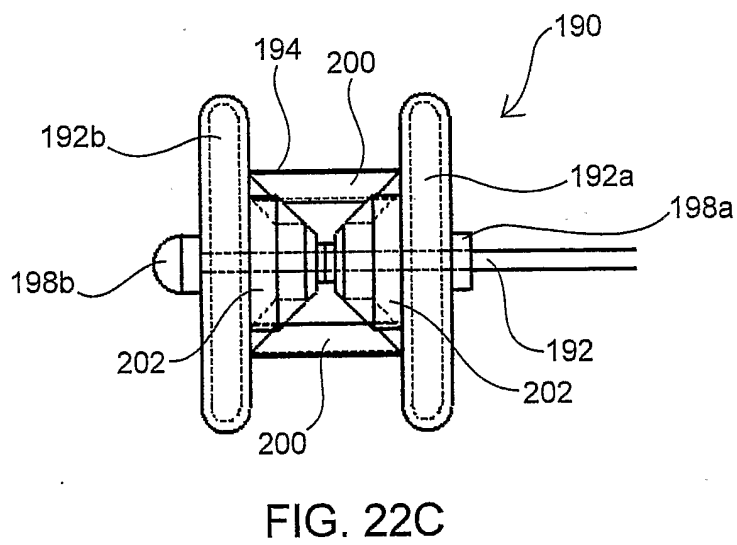
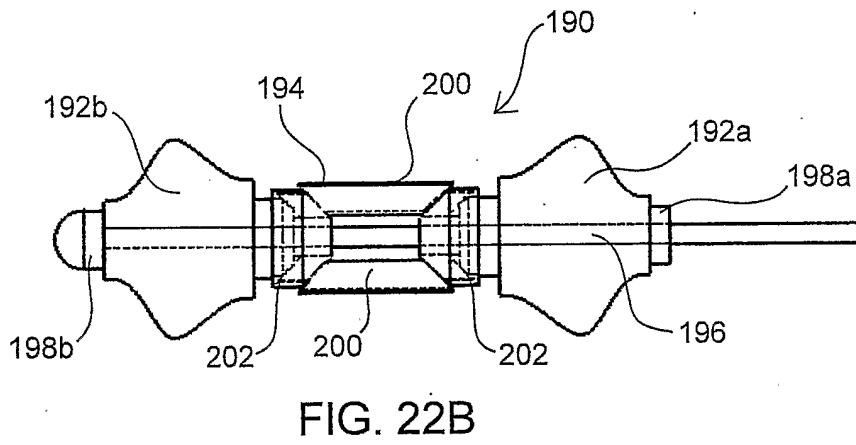
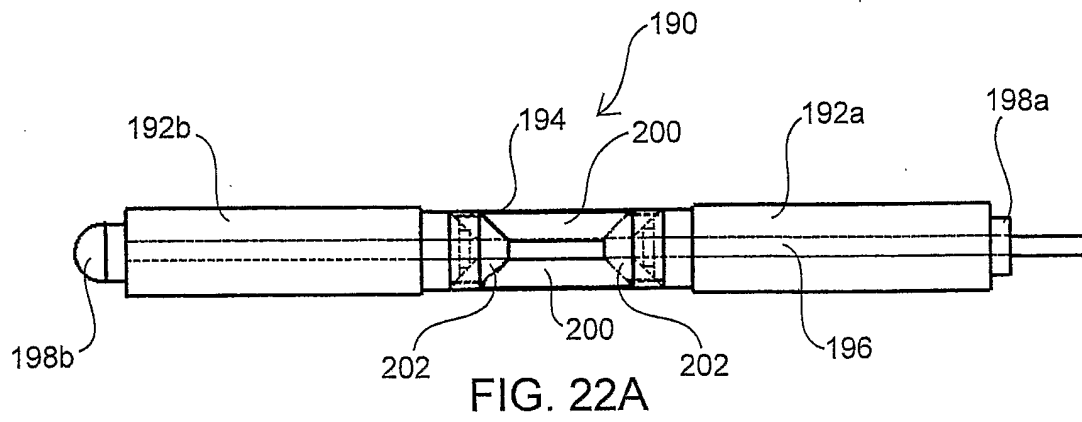

FIG. 21



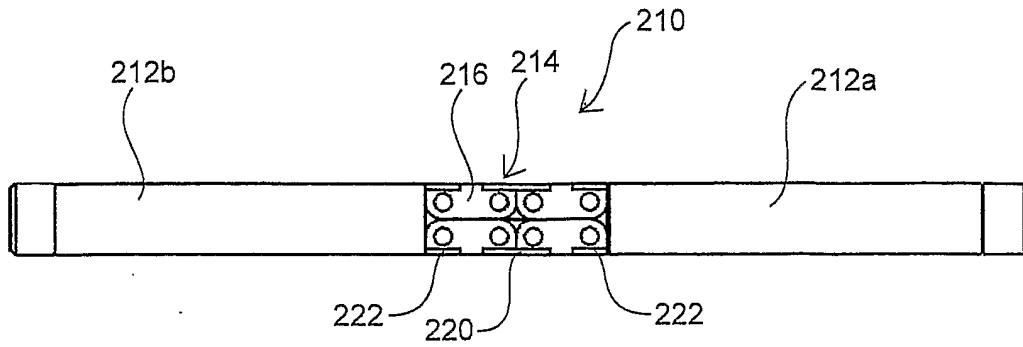

FIG. 23A

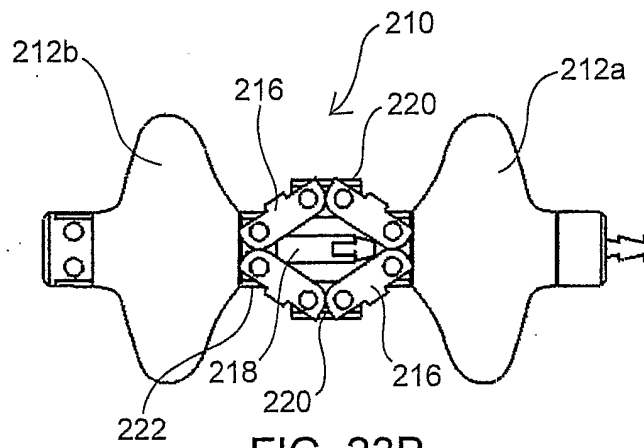

FIG. 23B

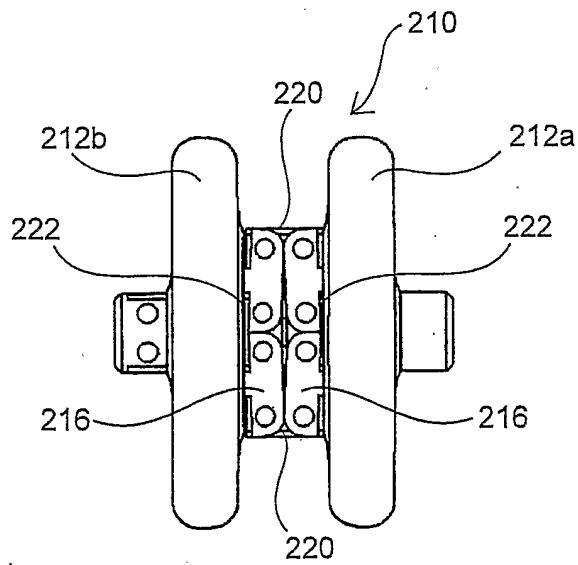
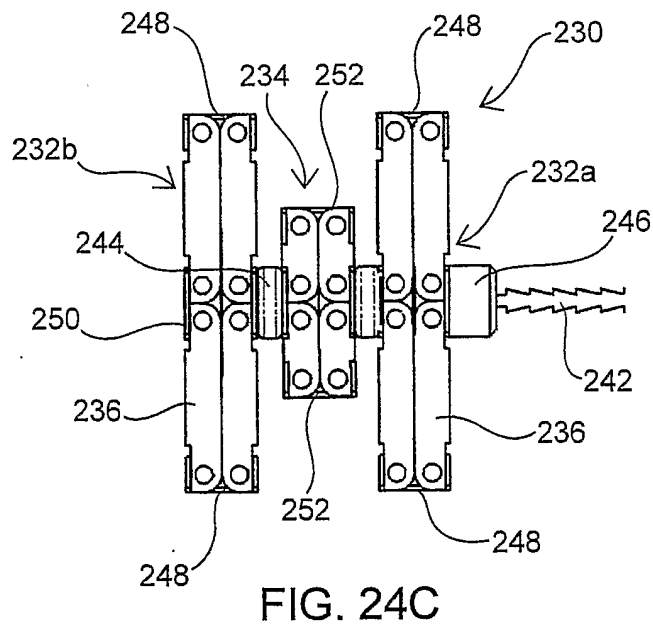
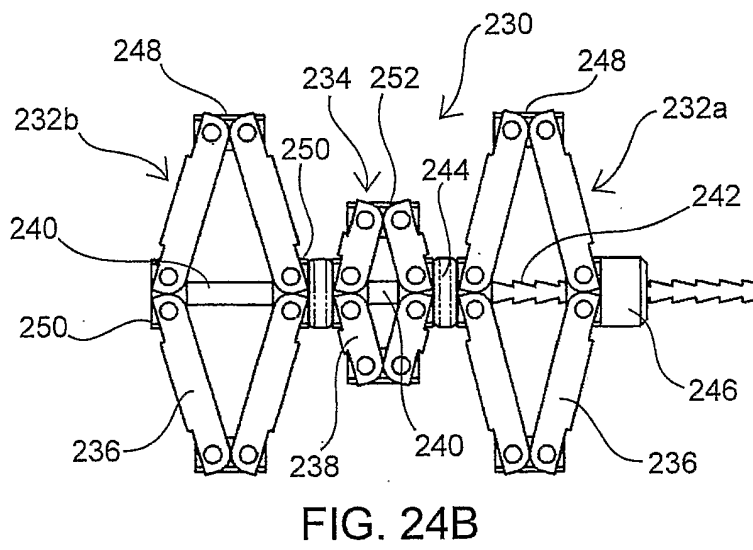
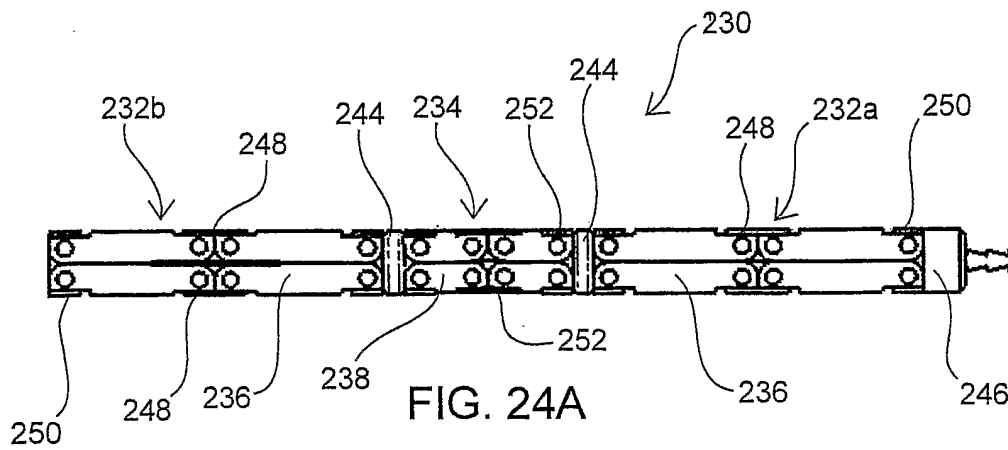

FIG. 23C



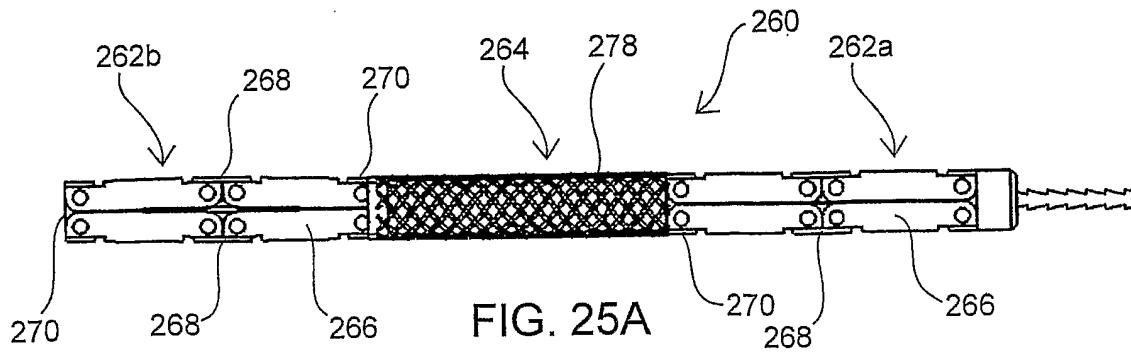

FIG. 25A

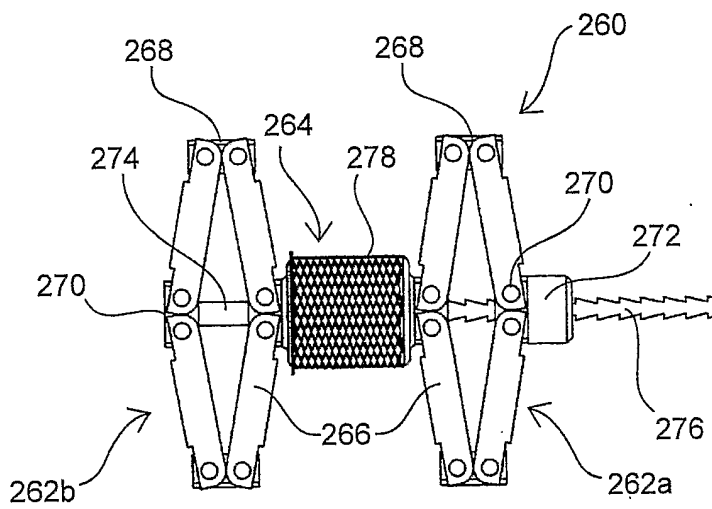

FIG. 25B

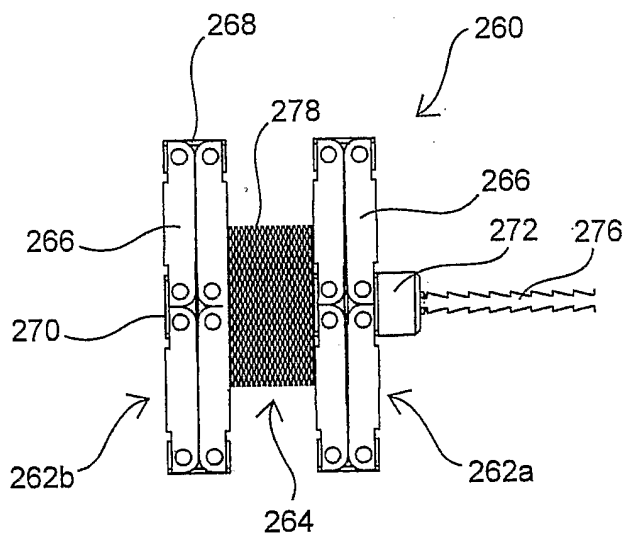

FIG. 25C

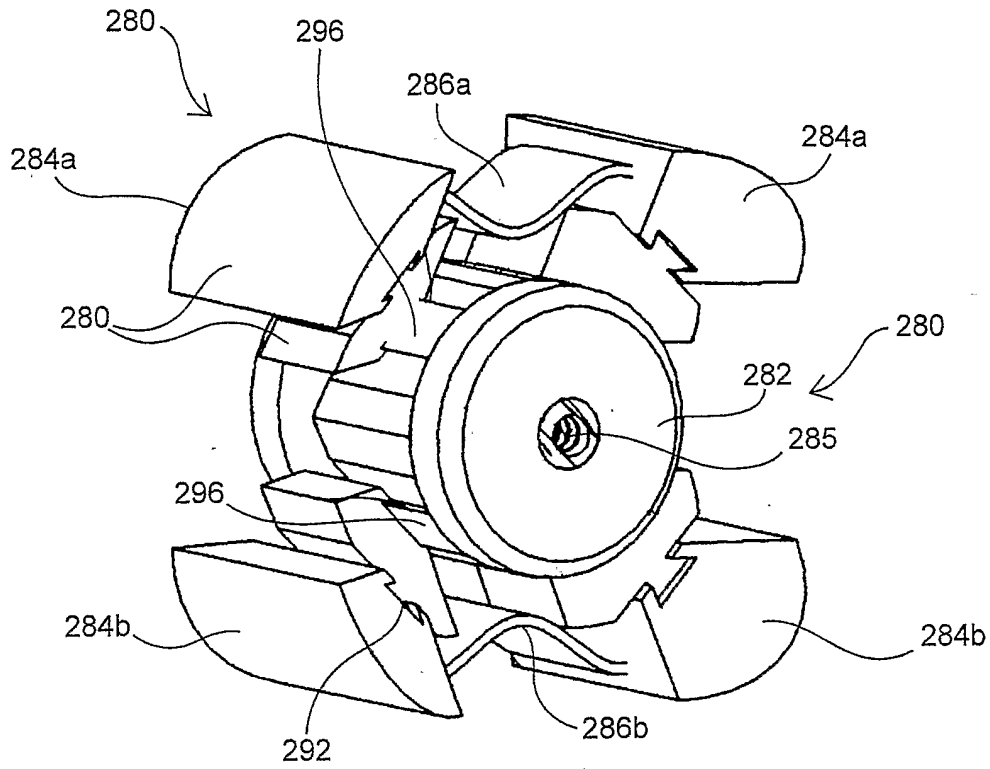

FIG. 26A

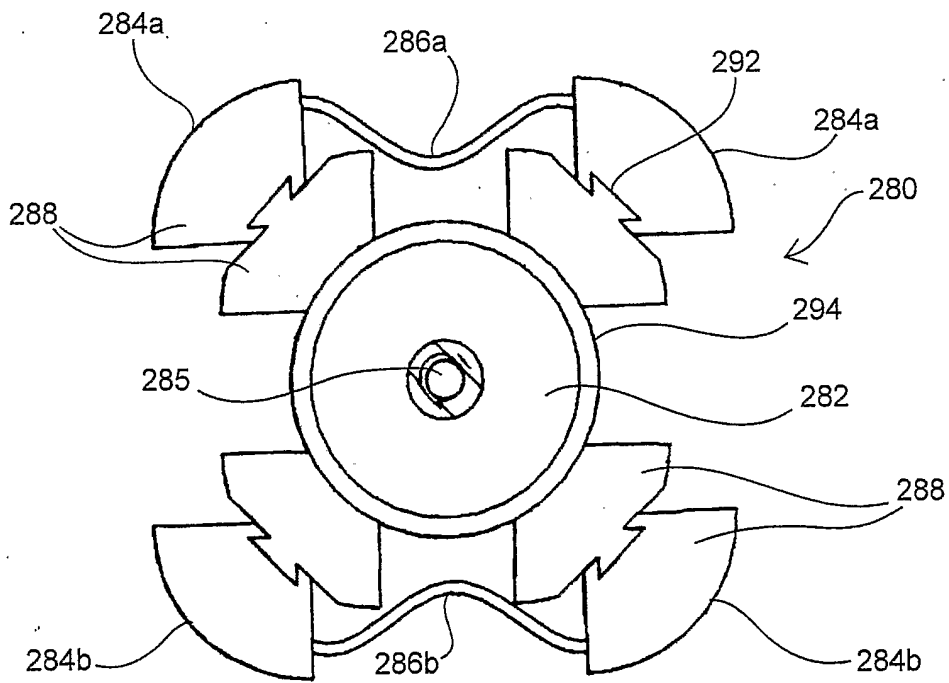

FIG. 26B

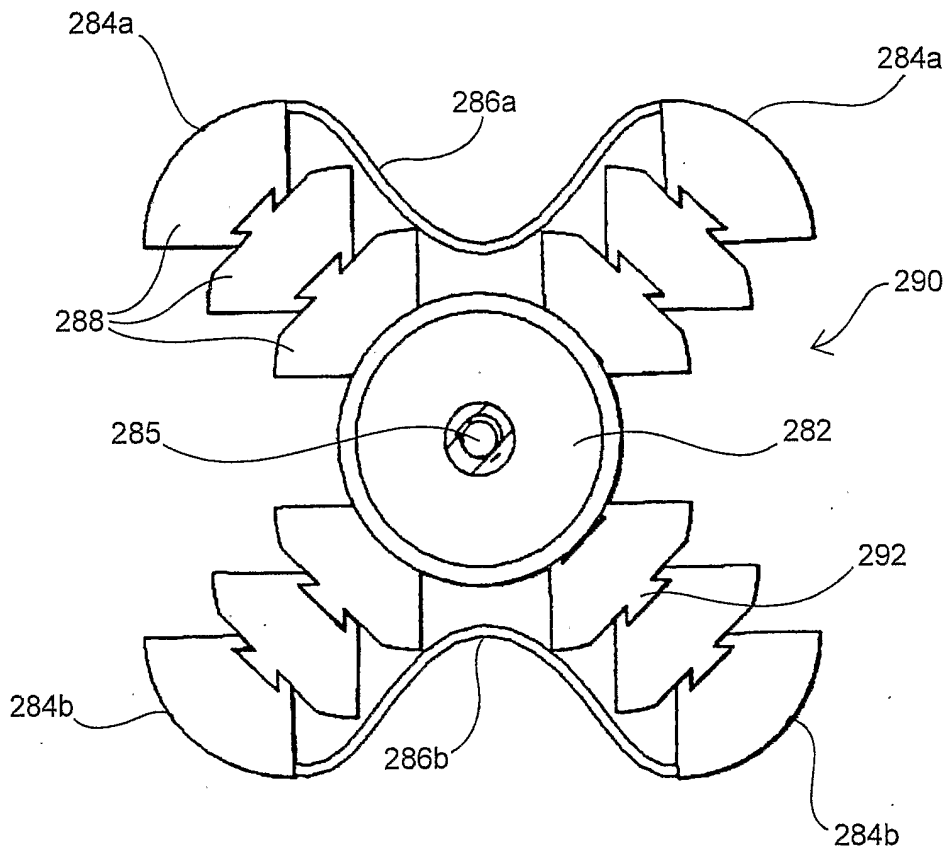

FIG. 27

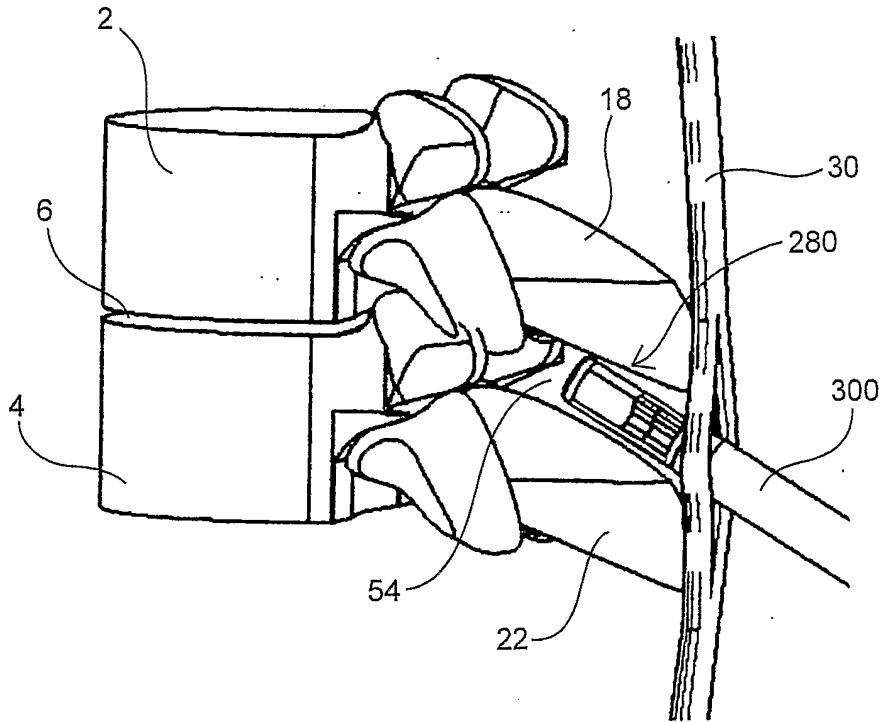

FIG. 28A

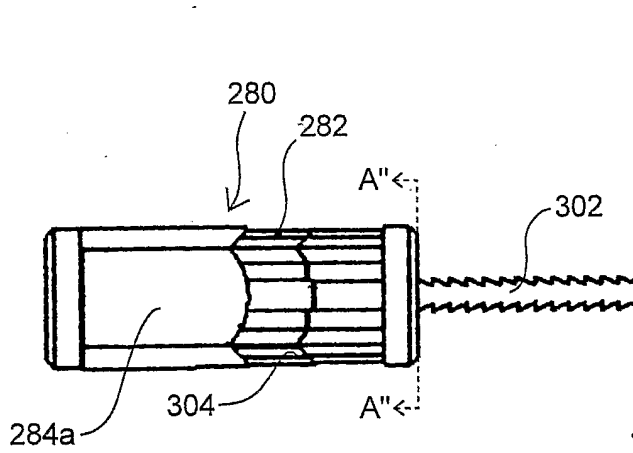

FIG. 28A'

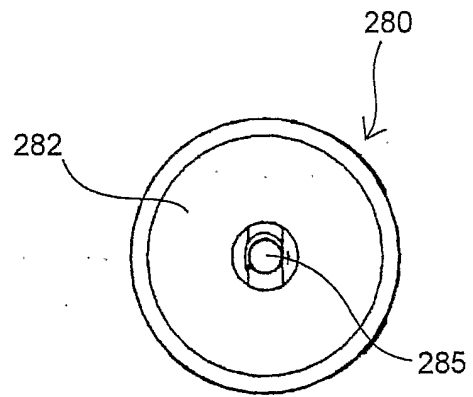
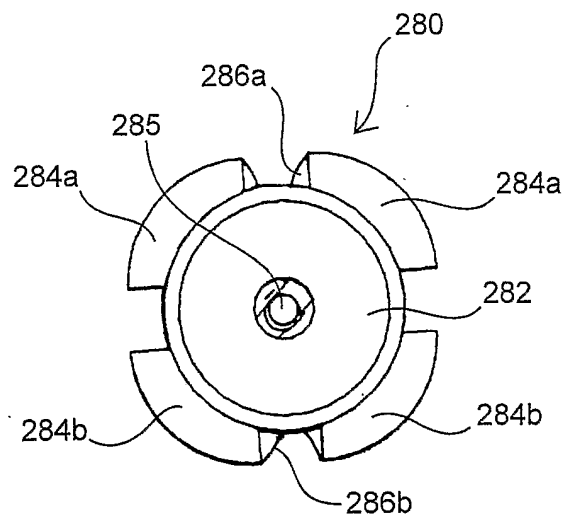
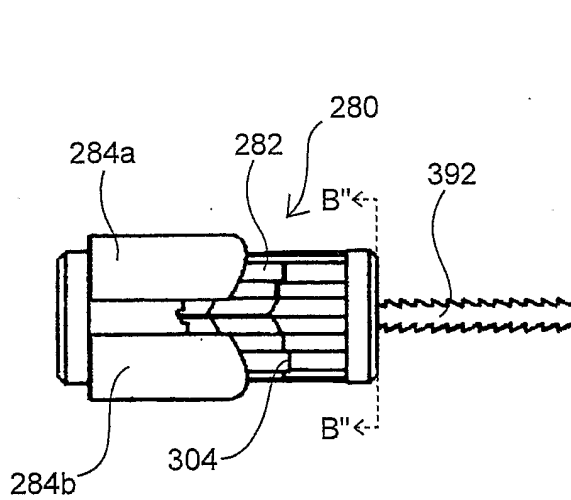
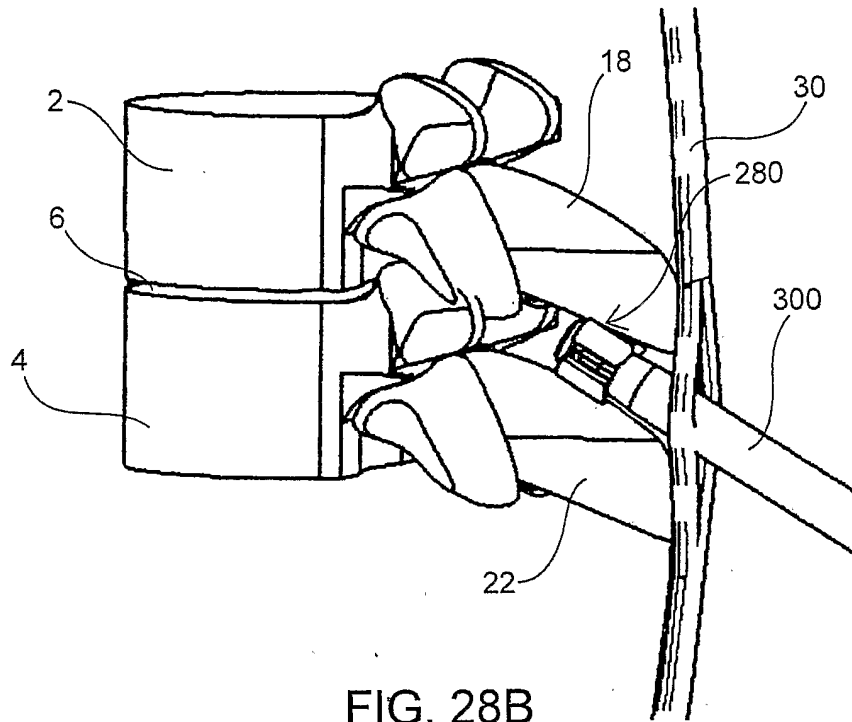

FIG. 28A''



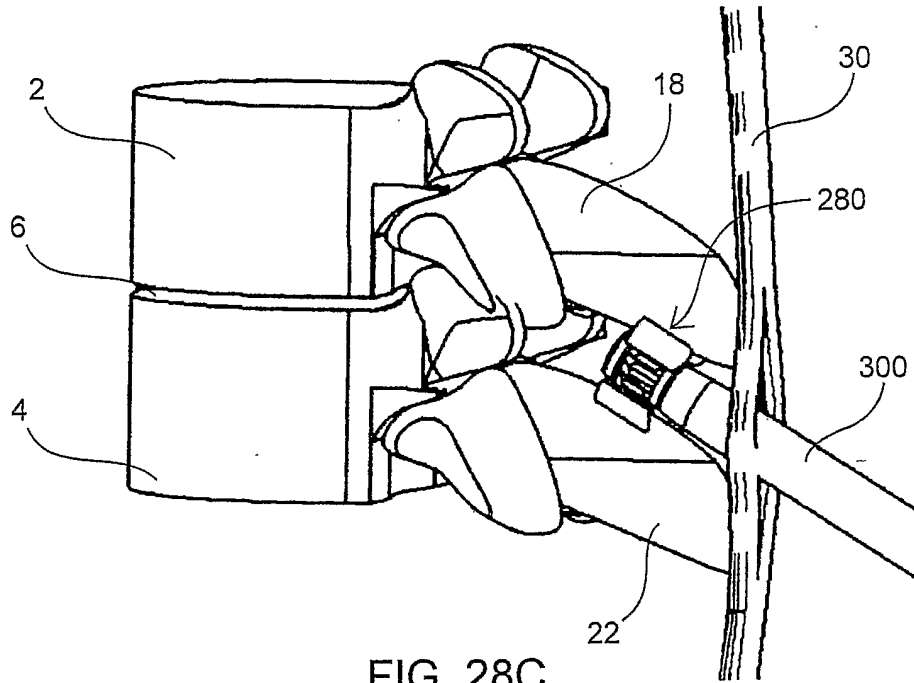

FIG. 28C

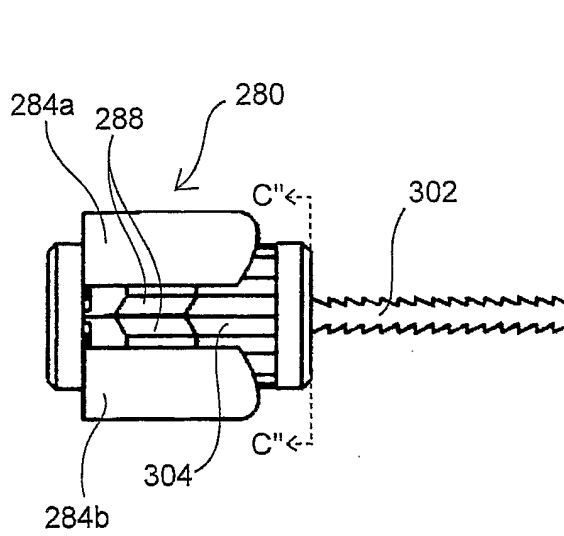

FIG. 28C'

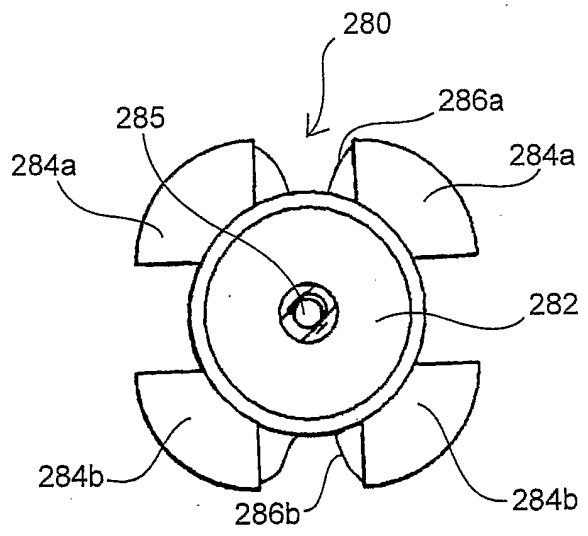
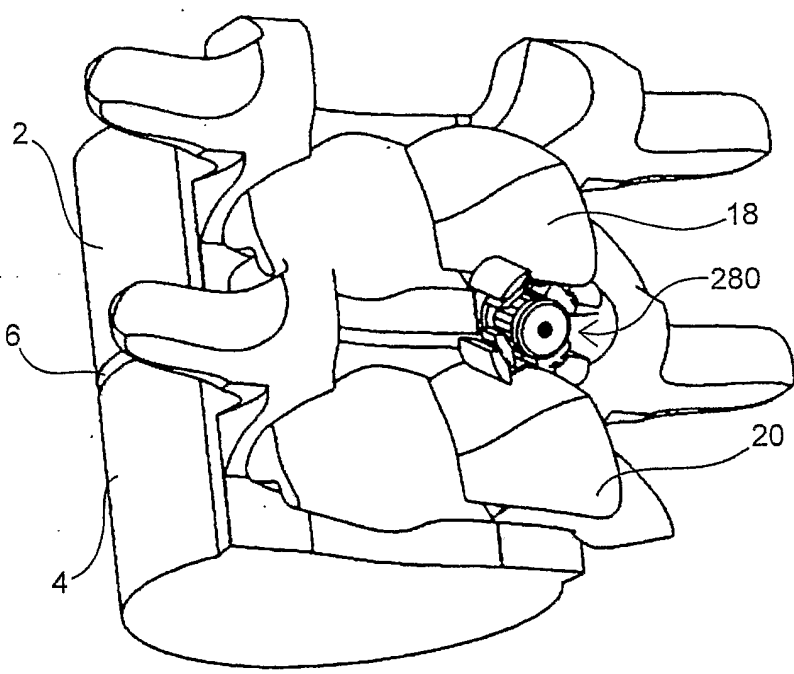
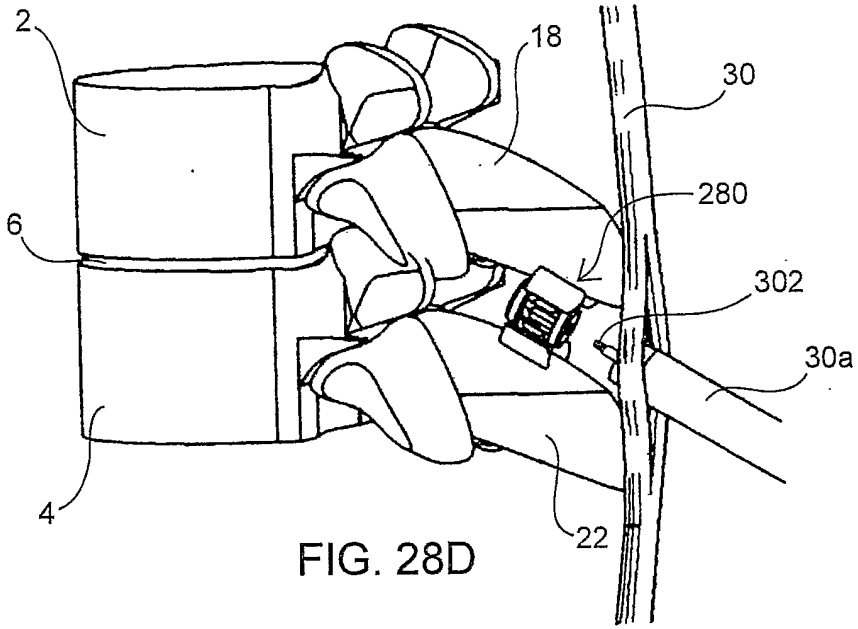

FIG. 28C''



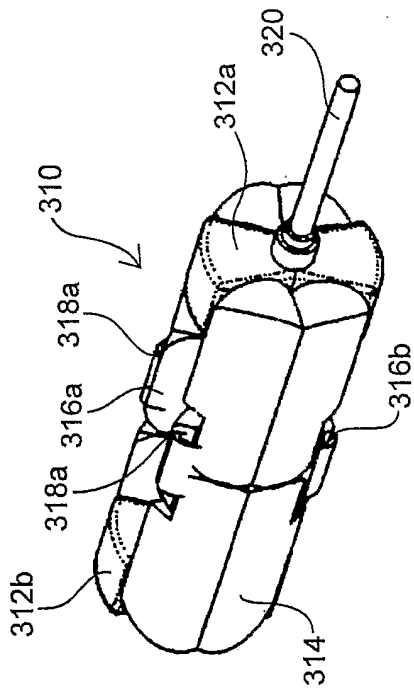

FIG. 29A

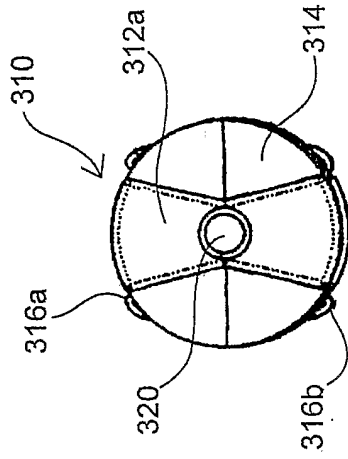

FIG. 29A'

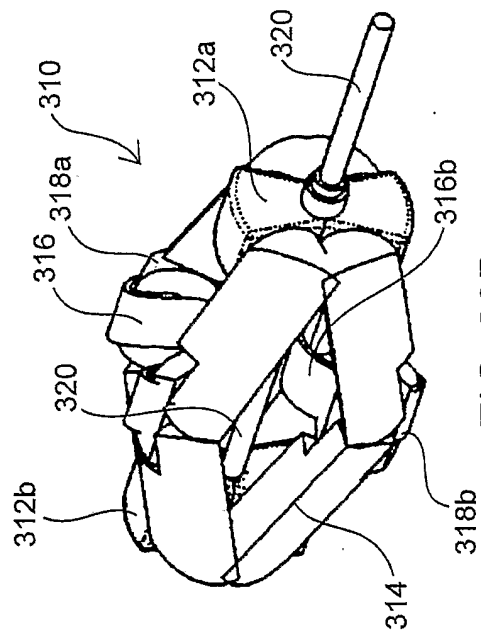

FIG. 29B

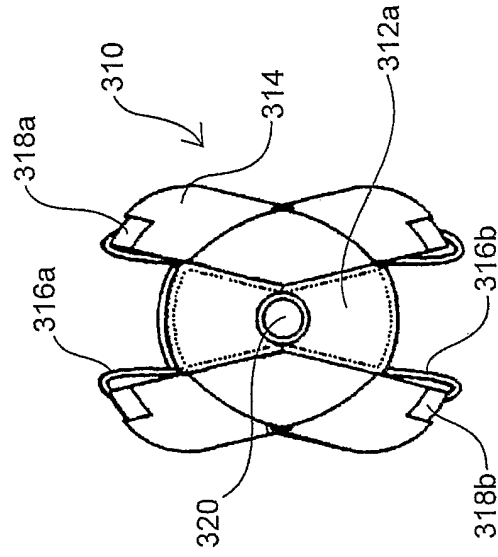

FIG. 29B'

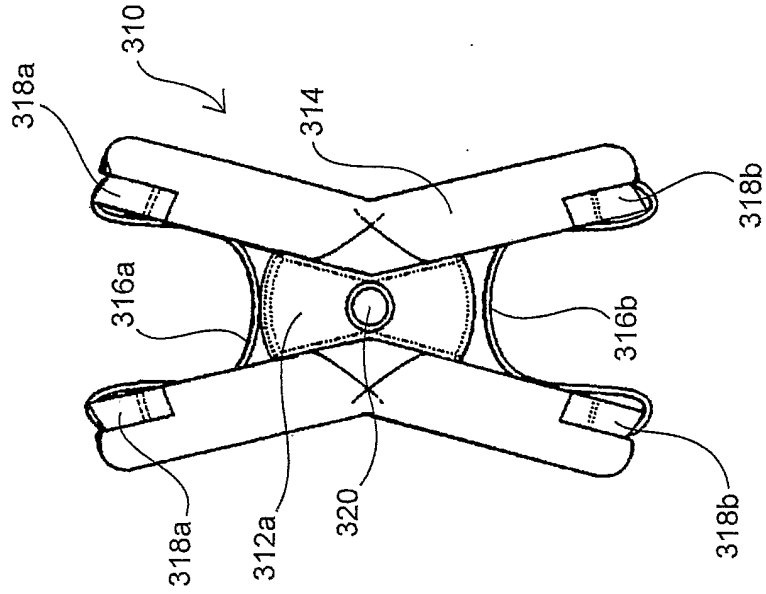

FIG. 29C'

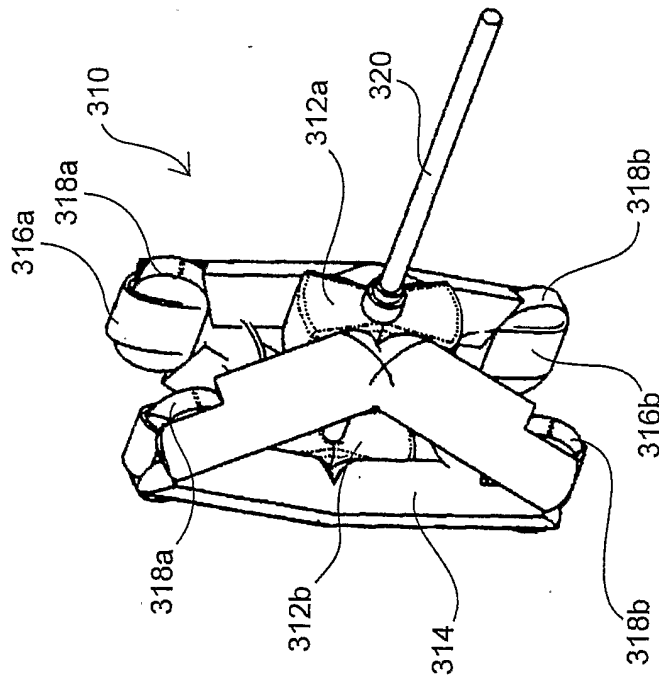

FIG. 29C

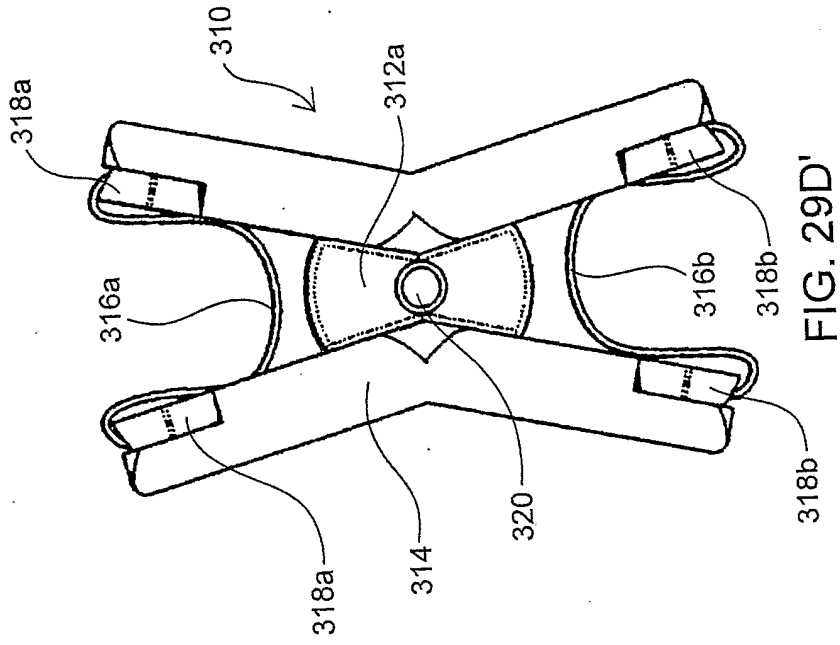

FIG. 29D'

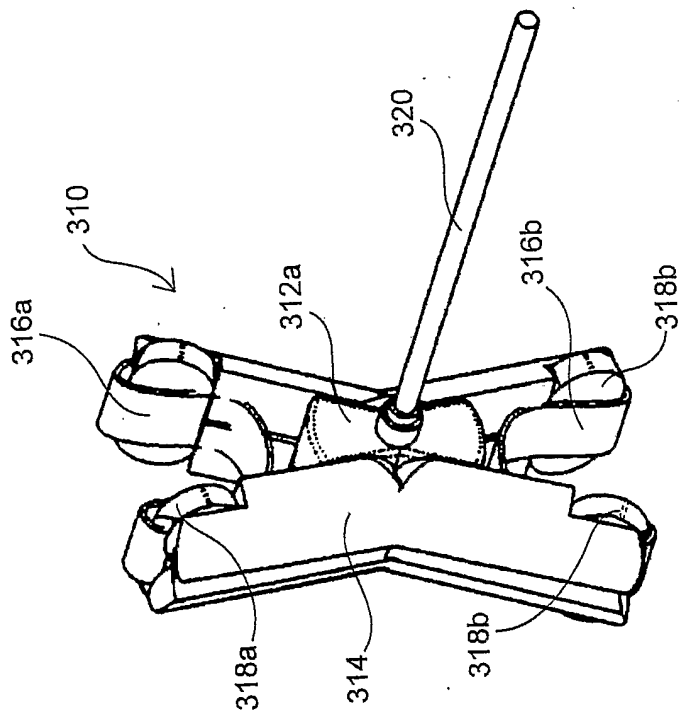

FIG. 29D

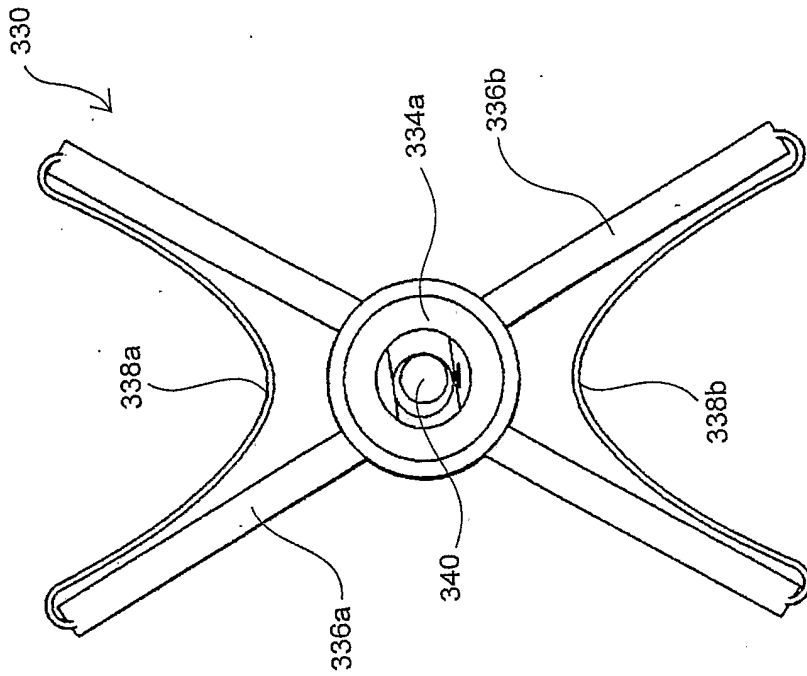

FIG. 30A'

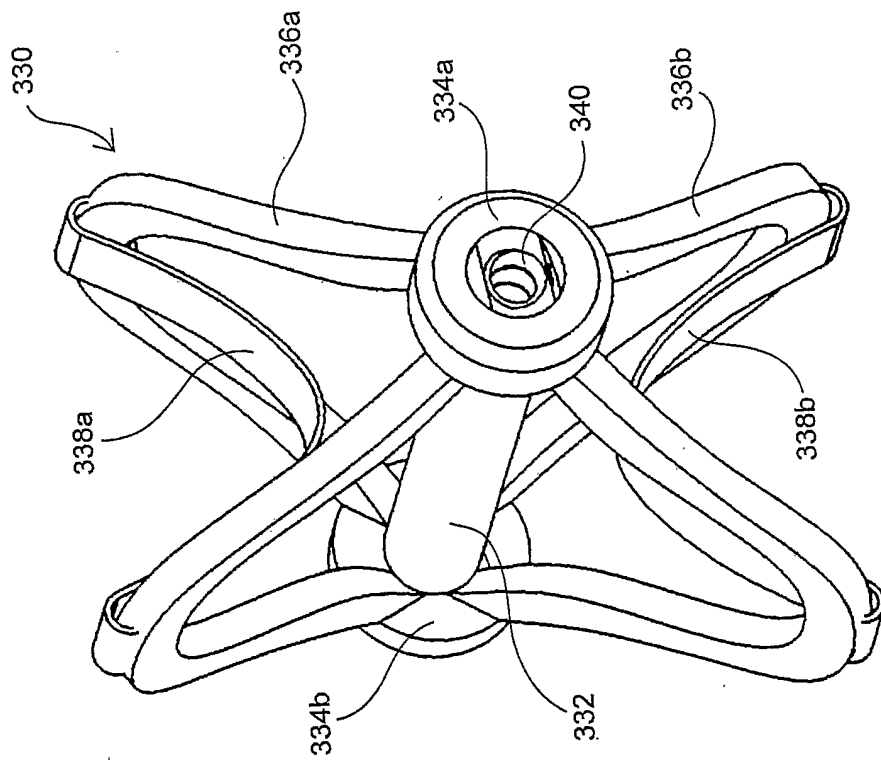

FIG. 30A

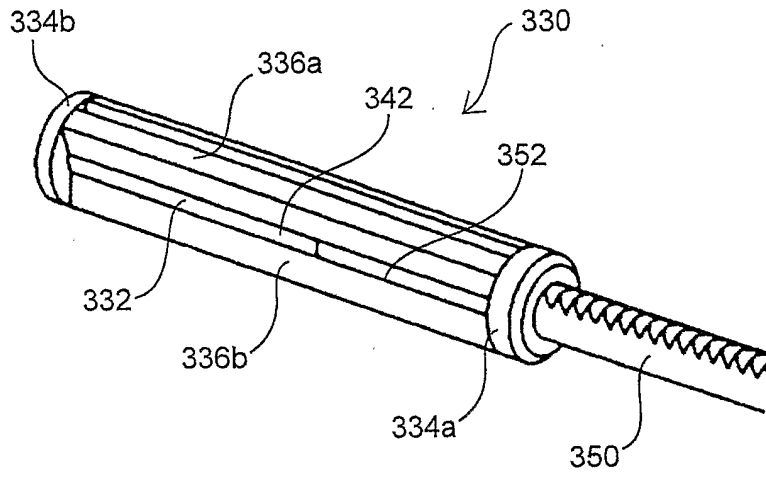

FIG. 30B

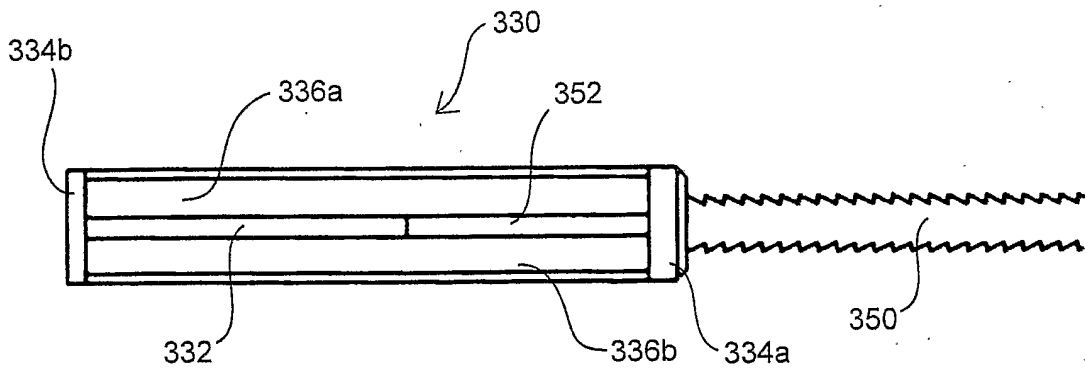

FIG. 30B'

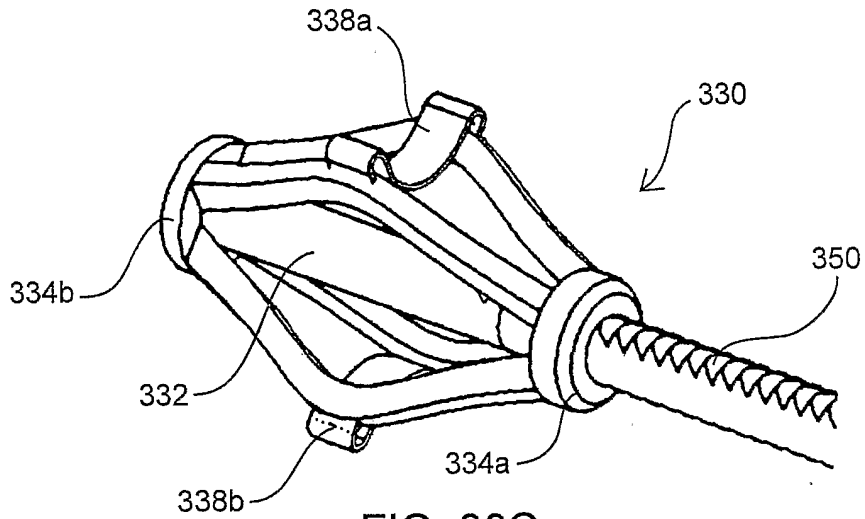

FIG. 30C

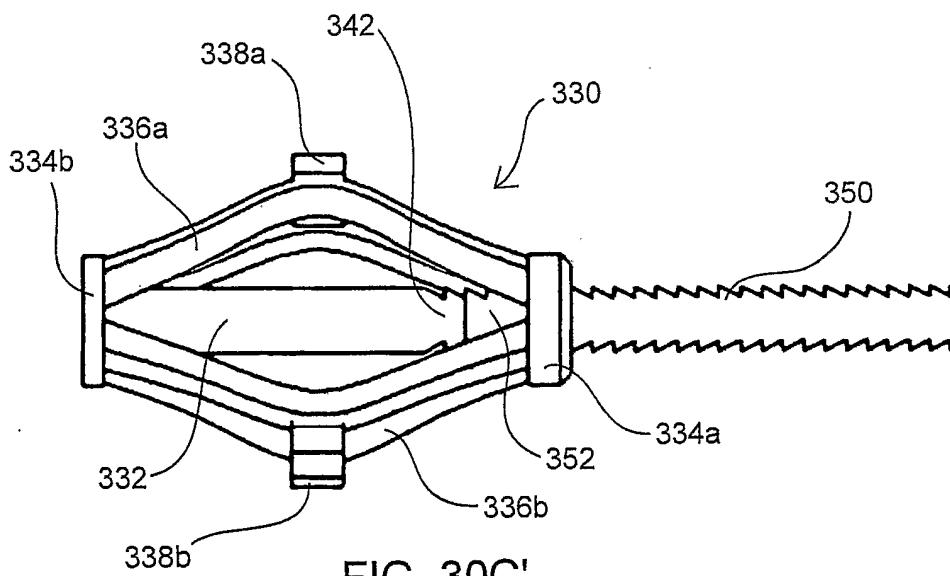

FIG. 30C'

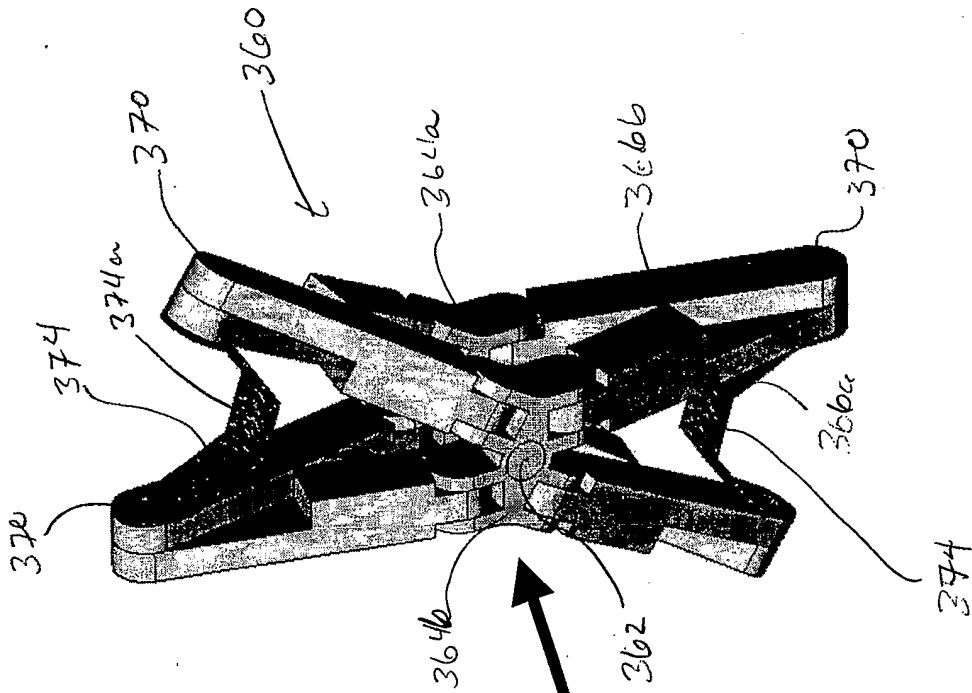

FIG. 31B

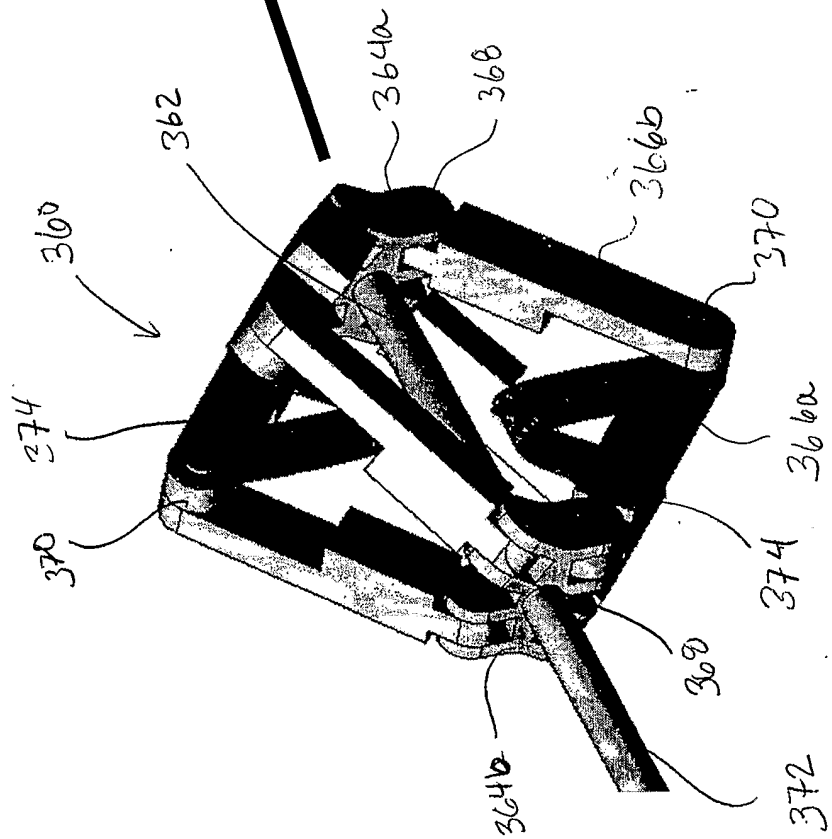

FIG. 31A