



(19) **United States**

(12) **Patent Application Publication**
Silverbrook

(10) **Pub. No.: US 2011/0148989 A1**

(43) **Pub. Date: Jun. 23, 2011**

(54) **INK EJECTION DEVICE EMPLOYING CORRUGATED THERMAL ACTUATOR**

(52) **U.S. Cl. 347/56**

(75) **Inventor: Kia Silverbrook, Balmain (AU)**

(57) **ABSTRACT**

(73) **Assignee: Silverbrook Research Pty Ltd**

(21) **Appl. No.: 13/037,088**

(22) **Filed: Feb. 28, 2011**

Related U.S. Application Data

(63) Continuation of application No. 12/276,379, filed on Nov. 23, 2008, now Pat. No. 7,921,645, which is a continuation of application No. 11/107,799, filed on Apr. 18, 2005, now Pat. No. 7,464,547, which is a continuation of application No. 10/258,518, filed on Oct. 25, 2002, now Pat. No. 6,978,613, filed as application No. PCT/AU01/00501 on May 2, 2001.

Publication Classification

(51) **Int. Cl. B41J 2/05 (2006.01)**

An ink ejection device for ejecting ink from a nozzle chamber includes an anchor block extending from a supporting substrate, the anchor block including a heating circuit; a first group of elongate corrugated arms attached at a first end to the heating circuit, the first group of elongate corrugated arms being in a first horizontal plane; a second group of elongate corrugated arms attached at a first end to the anchor block and electrically insulated from the heating circuit, the second group of elongate corrugated arms being in a second horizontal plane different from the first horizontal plane; a cross arm joining the first group of at least two elongate corrugated arms and the second group of at least two elongate corrugated arms at a second end of the corrugated arms; and a paddle attached to the cross arm. A first edge of the elongate corrugated arms of the first group and a first edge of the elongate corrugated arms of the second group are in a common horizontal plane between the first and second horizontal planes.

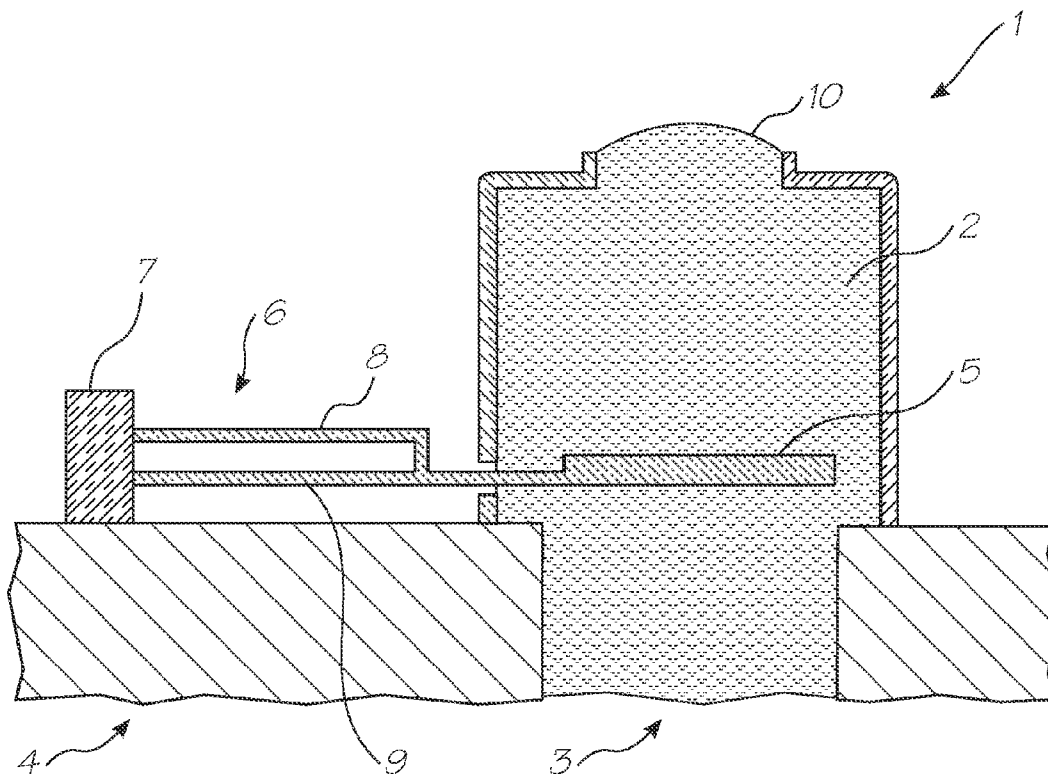

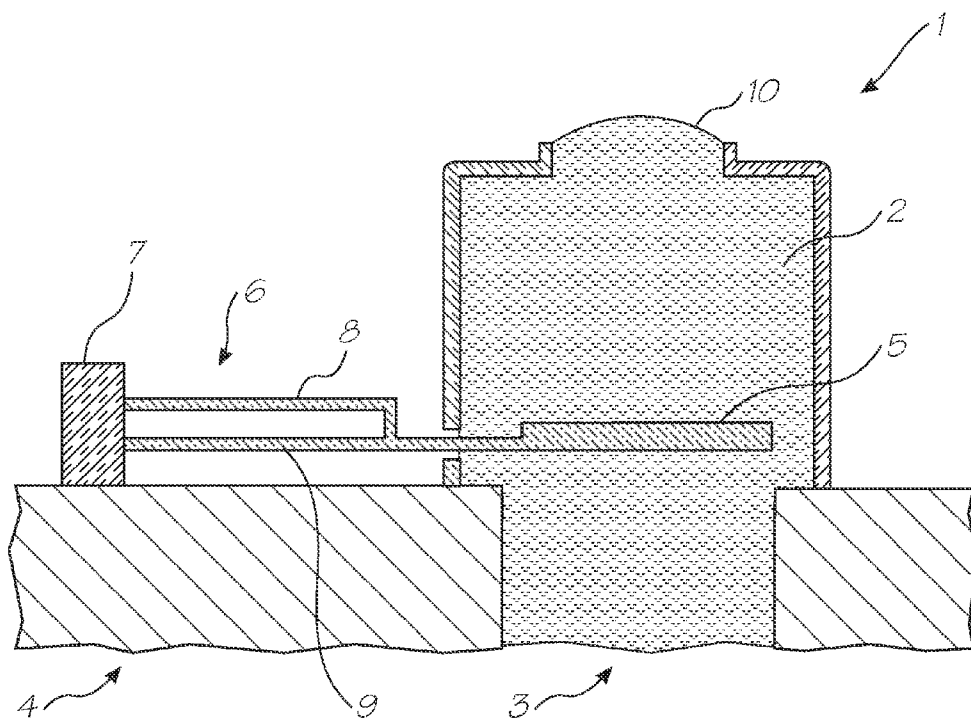

FIG. 1

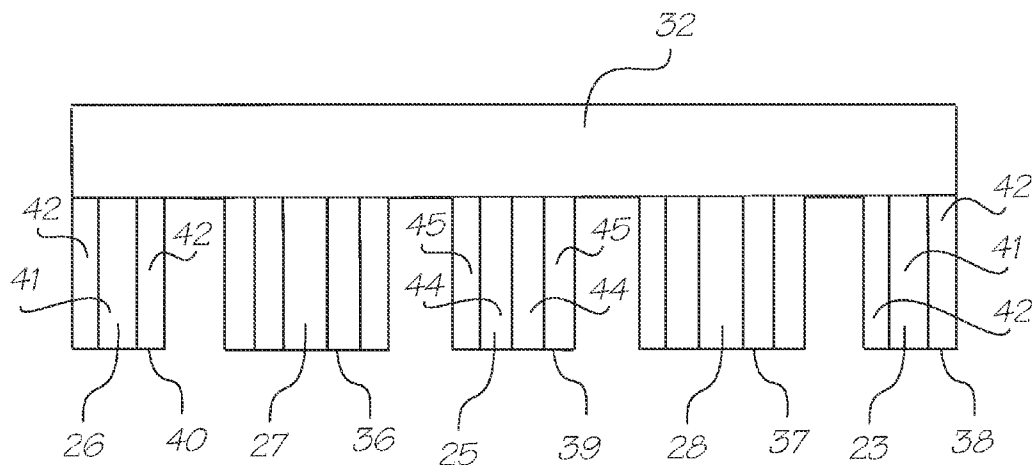

FIG. 2

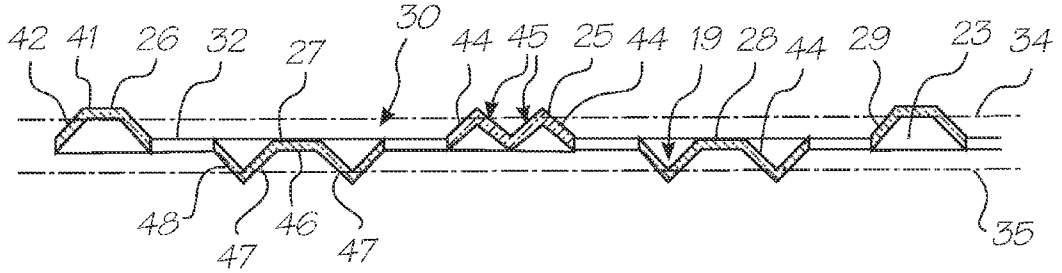

FIG. 3

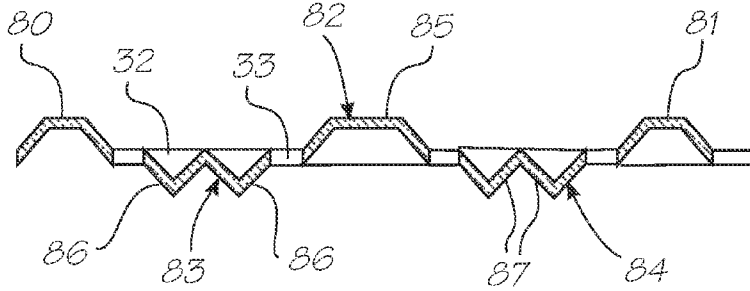

FIG. 4

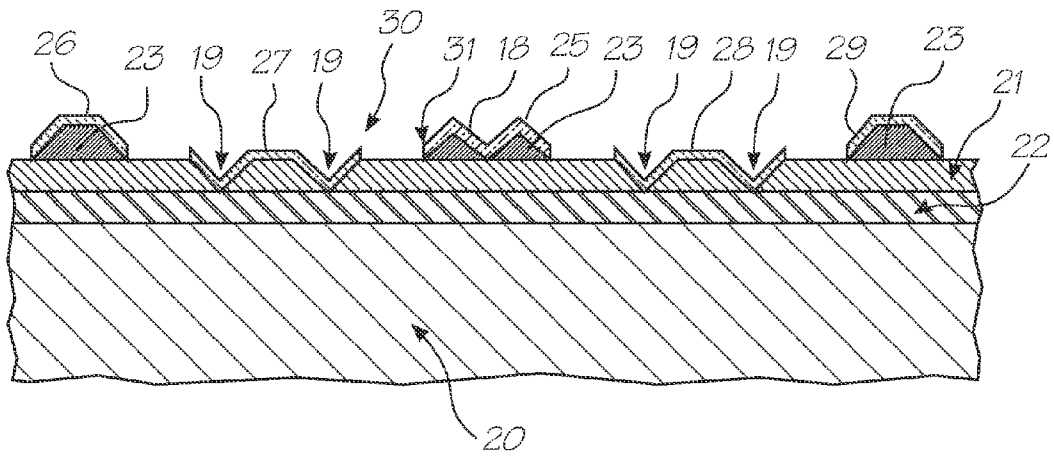

FIG. 5

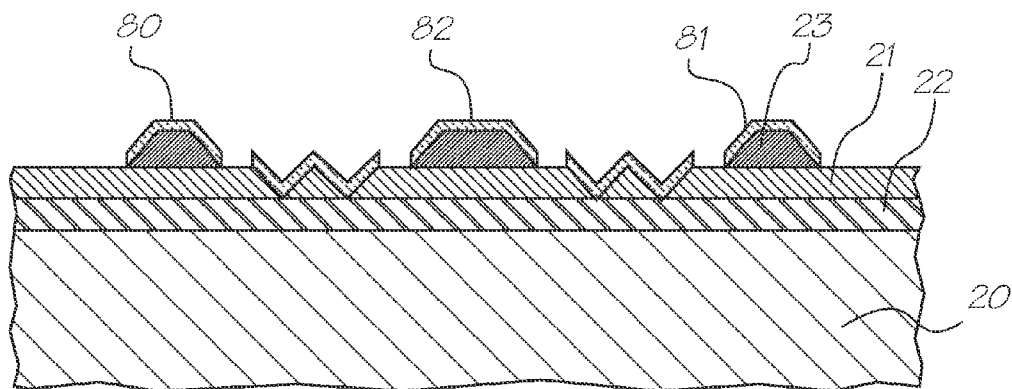

FIG. 6

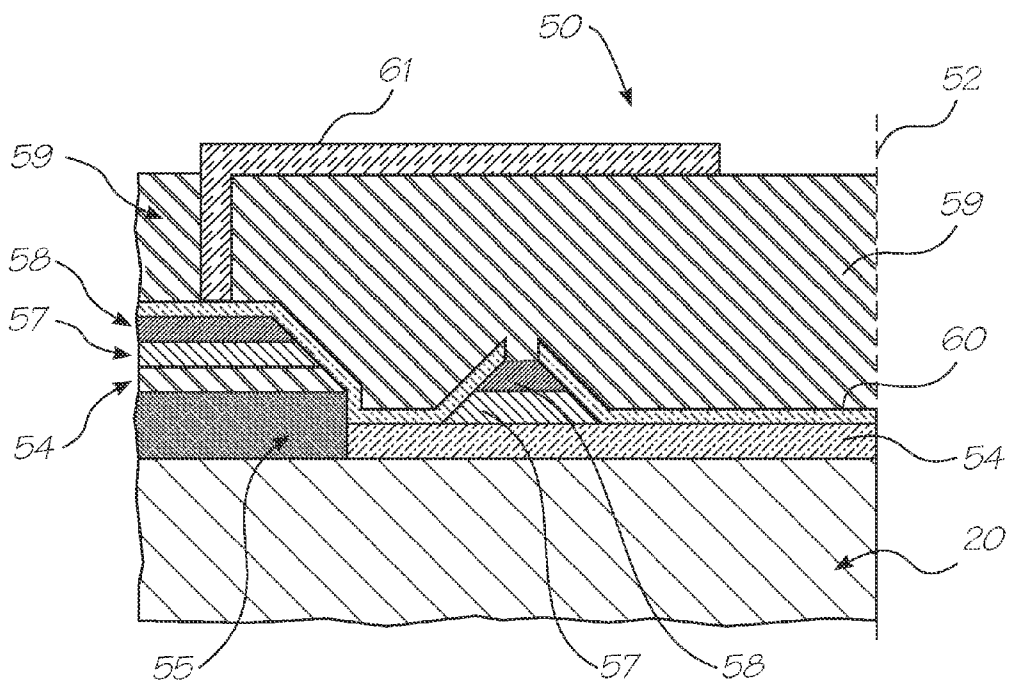

FIG. 7

INK EJECTION DEVICE EMPLOYING CORRUGATED THERMAL ACTUATOR

CROSS REFERENCE TO RELATED APPLICATION

[0001] This is a Continuation of U.S. application Ser. No. 12/276,379, filed Nov. 23, 2008, which is a Continuation Application of U.S. application Ser. No. 11/107,799 filed on Apr. 18, 2005, now issued as U.S. Pat. No. 7,464,547, which is a continuation of U.S. application Ser. No. 10/258,518 filed on Oct. 25, 2002, now issued as U.S. Pat. No. 6,978,613, which is a 371 of International Application Serial No. PCT/AU01/00501 filed on May 2, 2001 the entire contents of which are herein incorporated by reference.

FIELD OF THE INVENTION

[0002] The present invention relates to the field of micro electromechanical devices such as ink jet printers. The present invention will be described herein with reference to Micro Electro Mechanical Inkjet technology. However, it will be appreciated that the invention does have broader applications to other micro electro-mechanical devices, e.g. micro electro-mechanical pumps or micro electro-mechanical movers.

BACKGROUND OF THE INVENTION

[0003] Micro electro-mechanical devices are becoming increasingly popular and normally involve the creation of devices on the μm (micron) scale utilising semi-conductor fabrication techniques. For a recent review on micro-mechanical devices, reference is made to the article "The Broad Sweep of Integrated Micro Systems" by S. Tom Picraux and Paul J. McWhorter published December 1998 in IEEE Spectrum at pages 24 to 33.

[0004] One form of micro electro-mechanical devices in popular use are ink jet printing devices in which ink is ejected from an ink ejection nozzle chamber. Many forms of ink jet devices are known.

[0005] Many different techniques on ink jet printing and associated devices have been invented. For a survey of the field, reference is made to an article by J Moore, "Non-Impact Printing: Introduction and Historical Perspective", Output Hard Copy Devices, Editors R Dubeck and S Sherr, pages 207-220 (1988).

[0006] Recently, a new form of ink jet printing has been developed by the present applicant, which is referred to as Micro Electro Mechanical Inkjet (MEMJET) technology. In one form of the MEMJET technology, ink is ejected from an ink ejection nozzle chamber utilising an electro mechanical actuator connected to a paddle or plunger which moves towards the ejection nozzle of the chamber for ejection of drops of ink from the ejection nozzle chamber.

[0007] In previous designs of actuator a lower arm is deposited as a generally planar single layer, a sacrificial spacing layer is formed and then an upper arm is deposited as a generally planar layer.

[0008] A major portion of the cost of a manufactured wing semiconductor manufacturing techniques device depends on the number of separate layers required to be deposited during fabrication. Reducing the number of separate layers that need to be deposited reduces the cost of the device.

[0009] The efficiency of the thermal actuator is roughly inversely proportional to the mass of the actuator material.

The actuator arms need to have a certain stiffness. If the stiffness of the arms can be maintained whilst decreasing mass, the efficiency of the actuator can be improved.

[0010] The present invention, in preferred forms, aims to address either or both of these issues.

SUMMARY OF THE INVENTION

[0011] According to an aspect of the invention, an ink ejection device for ejecting ink from a nozzle chamber comprises an anchor block extending from a supporting substrate, the anchor block including a heating circuit; a first group of elongate corrugated arms attached at a first end thereof to the heating circuit, the first group of elongate corrugated arms being in a first horizontal plane; a second group of elongate corrugated arms attached at a first end to the anchor block and electrically insulated from the heating circuit, the second group of elongate corrugated arms being in a second horizontal plane different from the first horizontal plane; a cross arm joining the first group of at least two elongate corrugated arms and the second group of at least two elongate corrugated arms at a second end of the corrugated arms; and a paddle attached to the cross arm. A first edge of the elongate corrugated arms of the first group and a first edge of the elongate corrugated arms of the second group are in a common horizontal plane between the first and second horizontal planes.

BRIEF DESCRIPTION OF THE DRAWINGS

[0012] Notwithstanding any other forms which may fall within the scope of the present invention, preferred forms of the invention will now be described, by way of example only, with reference to the accompanying drawings, in which:

[0013] FIG. 1 shows, in schematic form, the operation of a thermal bend actuator ink jet printing device;

[0014] FIG. 2 shows a plan view of thermal bend actuator of a first embodiment of the invention;

[0015] FIG. 3 shows a cross-section of a thermal bend actuator of the first embodiment of the invention;

[0016] FIG. 4 shows a cross-section of a thermal bend actuator of a second embodiment of the invention;

[0017] FIG. 5 shows a cross-section of a thermal bend actuator according to the first embodiment partway through the manufacturing process;

[0018] FIG. 6 shows a cross-section of a thermal bend actuator according to the second embodiment partway through the manufacturing process; and

[0019] FIG. 7 illustrates a sectional view through a portion of a nozzle chamber which is formed simultaneously with the formation of the thermal bend actuator.

DESCRIPTION OF PREFERRED AND OTHER EMBODIMENTS

[0020] The basic operational principles of a liquid section which utilises a thermal actuator device will be explained with reference to FIG. 1. It is to be understood that the thermal actuator of the invention is not limited to use in such liquid ejection devices. As shown in FIG. 1, there is provided an ink ejection arrangement **1** which comprises a nozzle chamber **2** which is normally filled with ink so as to form a meniscus **10** around an ink ejection nozzle **11** having a raised rim. The ink within the nozzle chamber **2** is resupplied by means of ink supply channel **3**.

[0021] The ink is ejected from a nozzle chamber **2** by means of a thermal actuator **6** which is rigidly interconnected to a

nozzle paddle 5. The thermal actuator 6 comprises two arms 8, 9 with the bottom arm 9 being interconnected to an electrical current source so as to provide conductive heating of the bottom arm 9. When it is desired to eject a drop from the nozzle chamber 2, the bottom arm 9 is heated so as to cause rapid expansion of this arm 9 relative to the top arm 8. The rapid expansion in turn causes a rapid upward movement of the paddle 5 within the nozzle chamber 2. This initial movement causes a substantial increase in pressure within the nozzle chamber 2 which in turn causes ink to flow out of the nozzle 11 causing the meniscus 10 to bulge. Subsequently, the current to the heater 9 is turned off so as to cause the paddle 5 to begin to return to its original position. This results in a substantial decrease in the pressure within the nozzle chamber 2. The forward momentum of the ink outside the nozzle rim 11 results in a necking and breaking of the meniscus so as to form a meniscus and a bubble of ink 18. The bubble 18 continues forward onto the ink print medium as the paddle returns toward its rest state. The meniscus then returns to the position shown in FIG. 1, drawing ink past the paddle 5 in to the chamber 2. The wall of the chamber 2 forms an aperture in which the paddle 5 sits with a small gap there between.

[0022] FIGS. 2 and 3 show a first embodiment of a thermal bend actuator according to the invention.

[0023] The actuator has two lower arms, 27, 28 and three upper arms, 23, 25 and 26. All of the arms are formed as a unitary structure and are joined by an integral cross arm 32.

[0024] As best seen in FIG. 3, the edges of the upper and lower arms are located in a common plane 33. However, the lower arms 27, 28 are configured so as to extend below the common plane 33 whilst upper arms 23, 25, 26 extend above the common plane. The result is that the longitudinal centre of inertia for the upper arms is above the plane 33 and the longitudinal centre of inertia for the lower arms is below the plane, as indicated by lines 34 and 35 respectively.

[0025] The free ends 36, 37 of the lower arms are selectively connected to an electrical power source which causes current to pass from arm 27, into cross arm 32 and then into arm 28 (or vice versa), causing resistive heating of arms 27 and 28. The free ends 38, 39, 40 of arms 23, 25, 26 respectively are not connected to the electrical circuit so current does not flow into them. Thus, the arms 23, 25, 26 are not heated and do not expand. Ends 36, 37, 38, 39 and 40 are secured to an anchor block (7 in FIG. 1) so the thermal expansion in the length of the lower arms 27 and 28 results in an upward bending of the actuator as a whole about the anchor block. This, in turn, causes movement of whatever device, such as an ink ejection paddle, is connected to the actuator.

[0026] In cross-section outer arms 23 and 26 have a central horizontal portion 41 and two downwardly extending portions 42, which extend symmetrically downwards to the common plane 33.

[0027] The central arm 25 has, in cross section, two outer portions 44 and two inner portions 45. The two inner portions 45 extend symmetrically outwards and upwards relative to each other and the centre line of the arm 25. The outer portions 44 then extend downwardly and outwardly relative to the two inner portions to extend to the common plane 33.

[0028] The two lower arms 27 and 28 are identical and include a central portion 46 located in the common plane 33, two intermediate portions 47 extending downwardly from the central portion 46 and then two outer portions 48 extending upwardly to the common plane 33.

[0029] The two lower arms 27 and 28 are spaced equally between the central upper arm 25 and the outer arms 26 and 23 respectively so that arm 25 lies in the centre of the actuator as a whole. The total cross sectional area of the three upper arms 23, 25 and 26 is equal to the total cross sectional area of the two lower arms 27 and 28, but this is not essential. It will be appreciated that the non planar arms have a greater stiffness and hence resistance to bending compared to arms of the same cross sectional area.

[0030] FIG. 4 shows a cross-section of a second embodiment in which there are provided three upper arms and two lower arms. In plan view the configuration of the arms is the substantially the same as that shown in FIG. 2 for the first embodiment. The embodiment of FIG. 4 only differs in the cross sectional profile of the upper and lower arms.

[0031] The outer upper arms 80 and 81 have the same profile as arms 23 and 26 of the first embodiment. The central upper arm 82 is also similar to the outer arms 23 and 26 of the first embodiment in that it has a central portion with two outwardly and downwardly extending portions which terminate at the common plane 33. It will be noted that the width of the central portion 85 of arm 82 is greater than that of the two outer arms 80 and 81, but this is not essential and all three upper arms may be identical in cross section, if desired.

[0032] The two lower arms 83 and 84 are similar to those of the first embodiment but lack a central portion. Instead, outer portions 86 extend inwardly and downwardly from the common plane 33 to meet with inner portions 87 which extend outwardly and downwardly from the common plane 33 to form a W shape.

[0033] The arrangement of actuator arm cross-sections, as shown in FIGS. 2 and 3, provides for an increased stiffness in the thermal bend actuator without increasing the thickness of the layer through the corrugated nature of the actuator arms and reduces the occurrence of buckling during operation of the thermal bend actuator compared to an actuator with planar arms of the same total cross sectional area. This allows the cross sectional area, and hence mass, to be reduced, so increasing efficiency. In addition this allows stiffness to be increased to reduce the risk of buckling, with or without a reduction in mass.

[0034] As all the edges of the upper and lower arms are in the same plane, this provides for an increase in the exposure precision and allows either the actuator arms to be brought closer together than would be otherwise possible or to utilise equipment having a smaller depth of field (modern stepper equipment often operates over a depth of field of approximately 0.5 microns). In addition, as will be explained below, this also allows, in preferred embodiments for a simplified manufacturing process.

[0035] Whilst the total cross-sectional areas of the upper and lower arms in the two embodiments are similar, it is to be appreciated that the exact shape, cross section of each arm or total cross sectional area is not critical so long as the upper arms as a whole bend about an axis vertically distant from the axis about which the lower arms bend. Further whilst the edges of the arms preferably lie in a common plane, this is not essential.

[0036] In both of the embodiments described the effective moment of inertia and/or mass of the upper arms is preferably equal to that of the lower arms for optimum efficiency. However, this is not essential and the effective moment of inertia and/or mass of the two sets of arms may be different. In

addition the centres of inertia of the two sets of arms may be at unequal distances from the common plane 33.

[0037] It is also to be appreciated that the invention is not limited to the number of upper arms being in a ratio of 3:2 to the number of lower arms. For example, without limiting the scope of the invention, ratios of 2:2, 5:3, 4:4 are acceptable.

[0038] Manufacture of the thermal band actuator according to the invention will be described with reference to FIGS. 5 and 7 which shows cross sections of a partially fabricated ink ejection device utilising a thermal band actuator according to the first embodiment. FIG. 6 also shows a partially fabricated thermal bend actuator according to the second embodiment of the invention. The process steps of manufacture of the first and second embodiments are the same and it is only the design of the masks used that differentiate the end product.

[0039] Referring to FIG. 5, the manufacturing steps for the formation of the thermal bend actuator include the following steps:

[0040] 1. A CMOS wafer 20 is provided having the required electrical control structures formed thereon;

[0041] 2. A first sacrificial layer 22 is deposited and etched to form a generally planar spacer layer. The layer 22 is preferably deposited as a 2 microns thick layer of photo-imageable polyamide (PI) by spinning on the layer. The layer is then exposed through a first mask, developed and etched so as to remove unexposed regions and then hard-baked. During the hard-bake stage, the PI shrinks to 1 micron thickness.

[0042] 3. A second sacrificial layer 21 is deposited on selected areas of the first layer in the same manner as step 2, but utilising a different mask. The second layer 21 does not extend over all of the first layer but is laid so as to have gaps 19 between portions. On baking the PI layer shrinks and, as is its nature, it forms side walls which are angled at about 45 to the general horizontal plane on either side of the gaps 19. In the drawings the gaps 19 are shown as having minimal width at the interface with the first layer 22. However it is to be appreciated that the gaps 19 may have a significant width at the interface with the first layer 22;

[0043] 4. A third sacrificial layer 23 is then deposited onto selected areas of the second layer 21 to form three arms. Again the edges become angled upon baking in the same manner as in step 2;

[0044] 5. A single 0.25 micron layer of titanium nitride 18 is then deposited to cover all of the exposed first, second and third sacrificial layers 21, 22, 23. The titanium nitride layer is then etched by known means to remove material between the intended arms and to form gaps between the arms and pattern the layer 18 so as to form a thermal bend actuator having the cross-section of either FIG. 3 or FIG. 4, depending upon the mask pattern design in previous steps;

[0045] 6. A fourth sacrificial layer 59 of 6 micron thickness is then deposited so as to form a sacrificial structure for a nozzle chamber;

[0046] 7. A 1 micron layer of dielectric material 61 forming the nozzle chamber 2, is deposited;

[0047] 8. Subsequently, a 1 micron layer of sacrificial material comprising the fifth sacrificial layer (not shown) is deposited;

[0048] 9. A subsequent layer (not shown) is also deposited to form a nozzle rim, with the etch preferably being an anisotropic etch so as to leave a thin nozzle rim structure around the nozzle chamber;

[0049] 10. A nozzle guard structure (not shown), if required, is attached to the substrate. The nozzle guard structure can be independently micromachined to mate with the substrate;

[0050] 11. The nozzle guard is then affixed to UV-sensitive adhesive tape;

[0051] 12. The CMOS wafer is then back etched utilising a Bosch etching process to separate the wafer into printhead segments and to form an ink channel supply channel to the nozzle chamber; and

[0052] 13. the UV tape is then exposed to light so as to reduce its adhesiveness and to leave individual printhead segments which can be picked and placed for testing.

[0053] In the above process the titanium nitride layer for both sets of arms is laid down in one step. This results in a reduction in the process steps compared to depositing material for the two sets of arms sequentially. Further more the spacing of edges of adjacent arms is only limited by the accuracy of the stepper used.

[0054] The above steps simultaneously form both the thermal bend actuator and the nozzle chamber and paddle. For example, in FIG. 7, there is shown a portion 50 of the nozzle chamber (which is symmetrical around an axis 52). On the wafer 20 is formed the CMOS layer 55. The first sacrificial layer 54 is deposited and etched as are the second 57 and third 58 sacrificial layers. On top of the sacrificial layers is deposited a titanium nitride layer 60, which includes portions forming the paddle as well as the actuator. A subsequent fourth sacrificial layer 59 is deposited and etched. This is followed by a dielectric layer 61 which is deposited and etched so as to form the nozzle chamber proper. Subsequently, the sacrificial layers are etched away so as to release the bend actuator and simultaneously release the paddle structure.

[0055] It would be appreciated by a person skilled in the art that numerous variations and/or modifications may be made to the present invention as shown in the specific embodiment without departing from the spirit or scope of the invention as broadly described. The present embodiment is, therefore, to be considered in all respects to be illustrative and not restrictive.

I/We claim:

1. An ink ejection device for ejecting ink from a nozzle chamber, the ink ejection device comprising:

an anchor block extending from a supporting substrate, the anchor block including a heating circuit;

a first group of elongate corrugated arms attached at a first end thereof to the heating circuit, the first group of elongate corrugated arms being in a first horizontal plane;

a second group of elongate corrugated arms attached at a first end to the anchor block and electrically insulated from the heating circuit, the second group of elongate corrugated arms being in a second horizontal plane different from the first horizontal plane;

a cross arm joining the first group of at least two elongate corrugated arms and the second group of at least two elongate corrugated arms at a second end of the corrugated arms; and

a paddle attached to the cross arm, wherein

a first edge of the elongate corrugated arms of the first group and a first edge of the elongate corrugated arms of the second group are in a common horizontal plane between the first and second horizontal planes.

2. The device of claim 1, wherein the first horizontal plane is below the common horizontal plane.

3. The device of claim 2, wherein a longitudinal centre of inertia of the first group is above the common horizontal plane.

4. The device of claim 1, wherein the second horizontal plane is above the common horizontal plane.

5. The device of claim 4, wherein the longitudinal centre of inertia of the second group is below the common horizontal plane.

6. The device of claim 1, wherein an arm of said first group and/or an arm of said second group, has, in transverse cross-section, a U, V, C or W profile.

7. The device of claim 1, wherein said second group includes three elongate arms.

8. The device of claim 1, wherein the first and second groups of elongate corrugated arms are external to the nozzle chamber.

9. The device of claim 8, wherein the paddle extends into the nozzle chamber.

* * * * *