

[54] **BOX WITH FIVE PANEL ENDS**
 [75] Inventors: **Buddy E. Giebel; William H. Nation,**
 both of Monroe, Mich.
 [73] Assignee: **Union Camp Corporation, Wayne,**
 N.J.
 [22] Filed: **Mar. 9, 1972**
 [21] Appl. No.: **233,260**

2,858,058	10/1958	Kitchell.....	229/34 R X
3,001,685	9/1961	Blount.....	229/34 R
2,196,502	4/1940	Kells.....	229/34 R X
2,893,621	7/1959	Harnish et al.....	229/34 R
2,957,615	10/1960	Karr et al.....	229/34 R X
3,157,346	11/1964	Hamilton.....	229/34 R X
3,381,879	5/1968	Belcher et al.....	229/34 R

Primary Examiner—Davis T. Moorhead
 Attorney—Charles P. Bauer

[52] U.S. Cl..... 229/34 R
 [51] Int. Cl..... B65d 5/22
 [58] Field of Search..... 229/34

[57] **ABSTRACT**

A four-sided box having ends with five panels to provide added strength, which box is formed from a one piece blank of generally rectangular shape.

[56] **References Cited**
 UNITED STATES PATENTS
 2,454,573 11/1948 Scher..... 229/34 R

5 Claims, 9 Drawing Figures

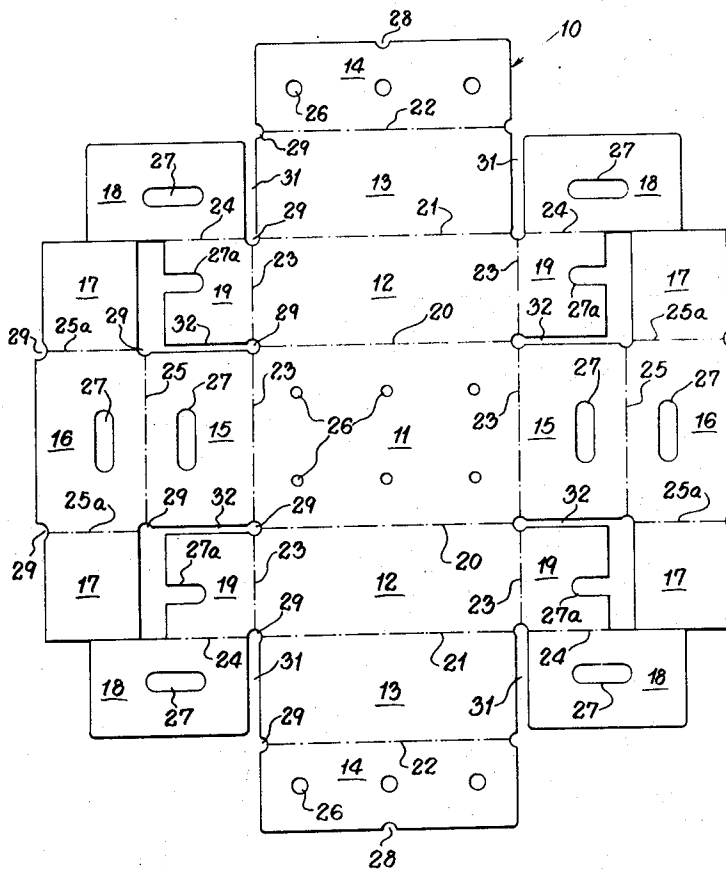

Fig. 1.

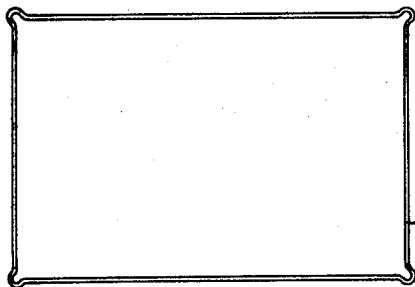
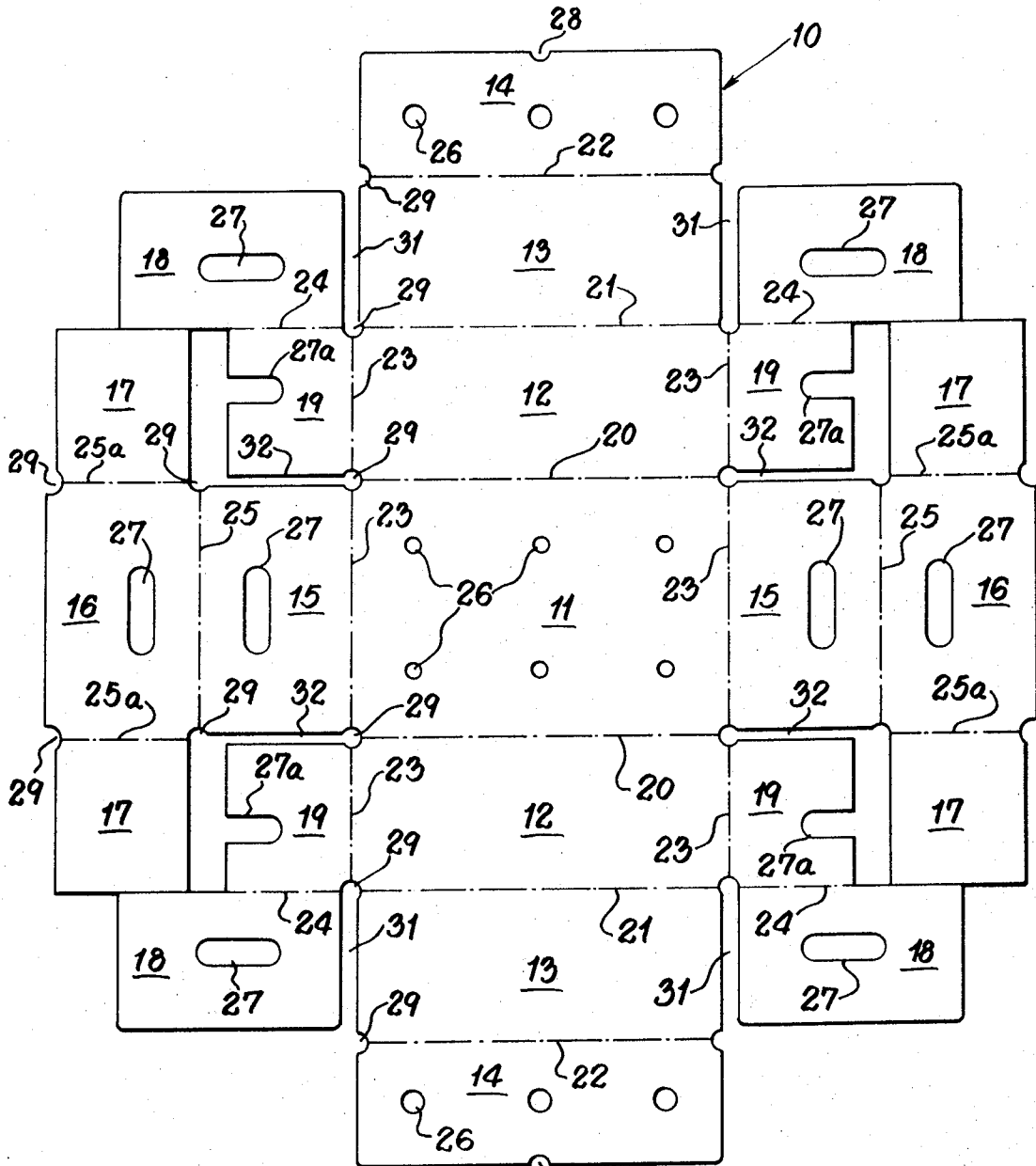
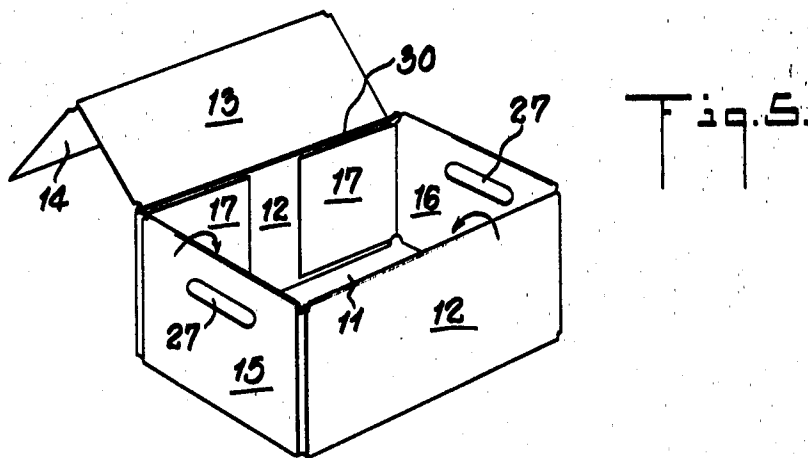
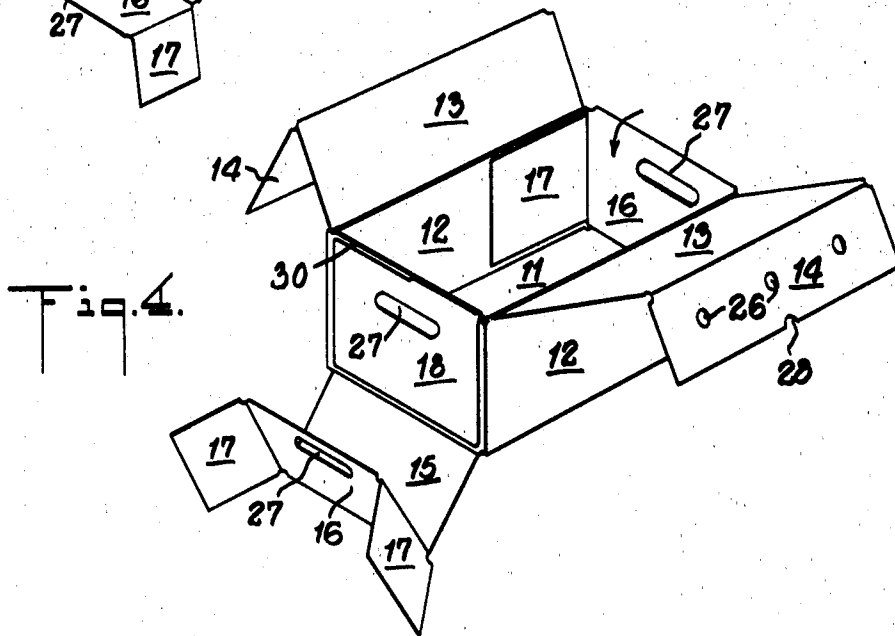
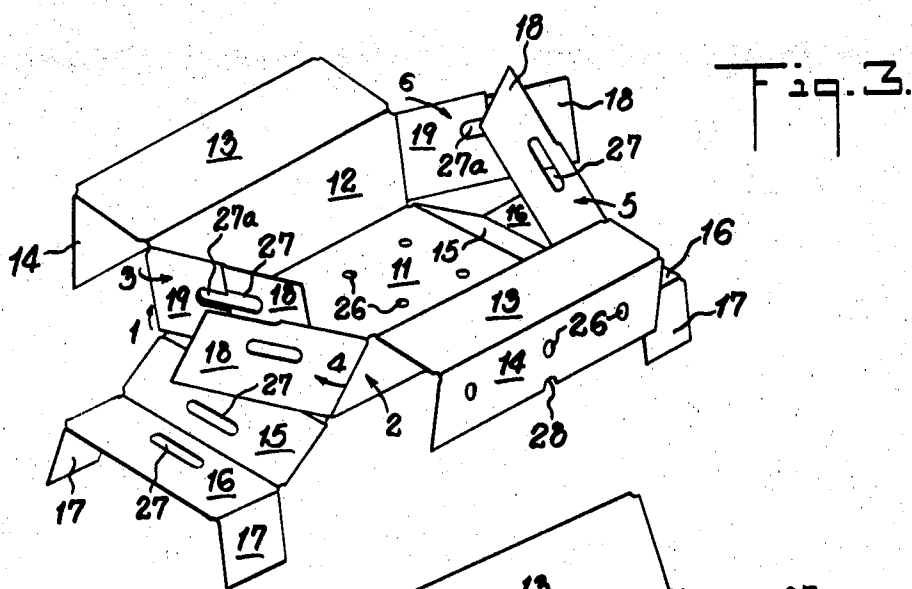

Fig. 2.



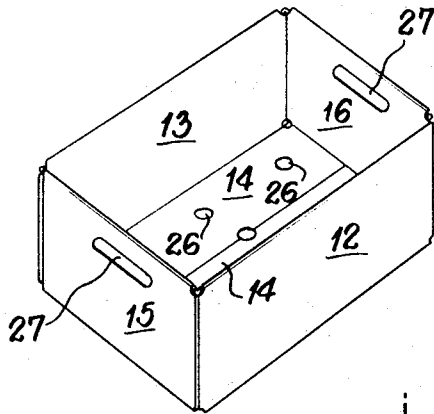

Fig. 6.

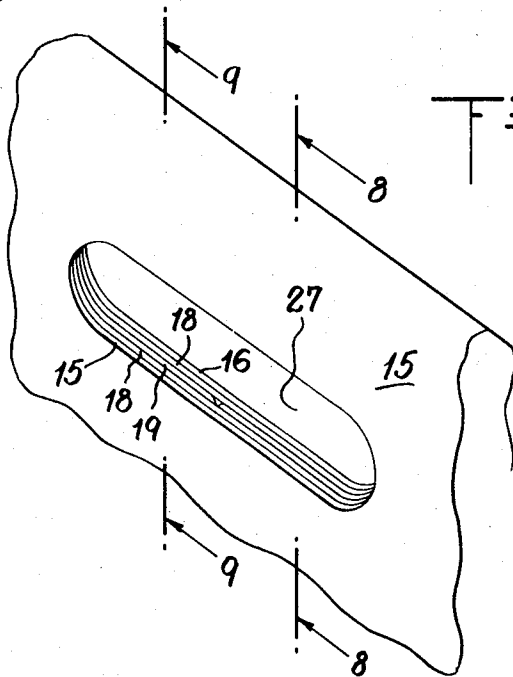

Fig. 7.

Fig. 8.

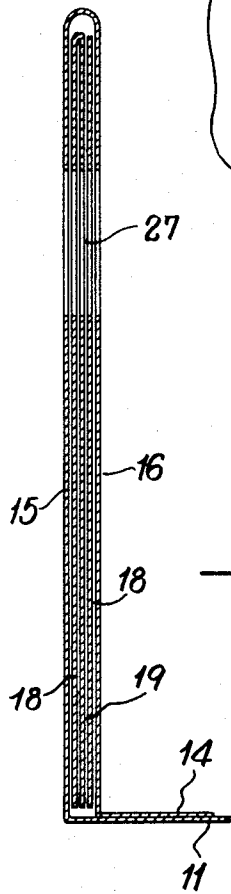
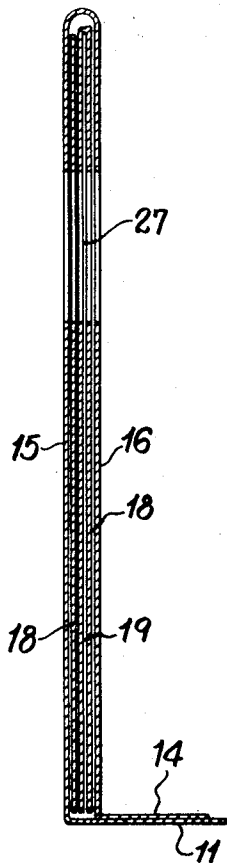

Fig. 8B.

BOX WITH FIVE PANEL ENDS**BACKGROUND OF THE INVENTION**

This invention relates to an improvement in boxes and, more particularly, to a box having ends formed of five panels, which construction provides a box with exceptional strength for the packaging of heavy products and for continued reuse. This box can be formed from a one-piece blank of generally rectangular shape. Such construction affords a box which is less expensive to make and assemble.

SUMMARY OF THE INVENTION

It is an object of the invention to provide a box with five panel ends for added strength.

It is a further object to provide a box with five panel ends which can be formed of a one-piece blank of generally rectangular shape.

It is a further object to provide a blank which is simple and economical to manufacture, can easily be set up into a box with five panel ends, which is efficient and well suited for its intended purpose.

BRIEF DESCRIPTION OF THE DRAWINGS

Other objects and advantages will become apparent from the following description which is to be taken in conjunction with the accompanying drawings, in which:

FIG. 1 is a plan view of a blank showing the score lines, cuts and slots which define the various parts of the box of the present invention;

FIG. 2 is a top view of the wire rim for reinforcing the top edge of the box;

FIGS. 3, 4 and 5 are perspective views of the blank of FIG. 1 in the various stages of setting up the blank into a box;

FIG. 6 is a perspective view of the blank of FIG. 1 completely set up ready for use;

FIG. 7 is a perspective partial view of the end of the box of FIG. 6 showing the five panels at the end of the box;

FIG. 8 is a cross-sectional view along the line 8—8 of FIG. 7; and

FIG. 9 is a cross-sectional view along the line 9—9 of FIG. 7.

DESCRIPTION OF THE PREFERRED EMBODIMENT

Referring to the drawings there is shown in FIG. 1 a flat generally rectangular blank 10 of sheet material, such as corrugated board, fibre board or the like, of a weight suitable for the type of carton to be constructed. The blank 10 has been cut and scored and consists of outer bottom panel 11, outer side panels 12, inner side panels 13, inner bottom half panels 14, outer end panels 15, inner end panels 16, intermediate side partial panels 17, intermediate end panels 18, and intermediate end half panels 19. The outer bottom panel 11, the outer side panels 12, the inner side panels 13 and the inner bottom half panels 14 are interconnected along generally parallel score lines respectively 20, 21 and 22. The outer end panels 15 and the end half panels 19 are connected respectively to the bottom panel 11 and the outer side panels 12 along generally parallel score lines 23. Intermediate side panels 18 are connected to the intermediate end half panels 19 along score lines 24. The outer end panels 15 and the inner end panels

16 are connected along score lines 25. The intermediate side partial panels 17 are connected to the inner end panels 16 along score lines 25a.

The bottom panels 11 and 14 may be provided with ventilation holes 26 which are positioned to match when the blank is folded into a box and the inner bottom half panels 14 overlie the outer bottom panel 11. The various end panels 15, 16, 18 and 19 may be provided with handholes 27 or half handholes 27a which are positioned to match when the blank is folded into a box and the said panels are superimposed, thus constituting a single handhole at each end of the setup box. The inner bottom half panels 14 may also be provided with a thumb hole 28 which will permit gripping the panels for knocking the box down, if necessary for shipment in flat form.

The corners of the various panels may be provided with circular cutouts 29 which will appear as cutouts in the bottom and top corners of the setup box. This permits insertion of a metal reinforcing member 30 (FIG. 2) in the upper rim of the box when the panels are folded in place. It also facilitates the folding and setting up of the box. Extending outwardly from the ends of the score line 23 are slots 31 which separate the panels 13 and 18. Likewise the slots 32 at the ends of the score lines 20 separate the panels 15 and 19.

FIGS. 3 through 6 illustrate how the blank can be set up into a box without the necessity of any stitching, tape or tools. The panels 12 hinged to the outer bottom panel 11 are erected to a generally upright position. The intermediate end panels 18 are folded 180° to lie flat against the intermediate end half panels 19 with the panel 18 on one side being folded inwardly and the opposite panel 18 on the other side being folded outwardly (FIG. 3). The four panels 18 and 19 are then superimposed so that the end of one panel 18 butts the end of the other panel 18 at approximately the center of the end. Panels 15 are raised to an upright position to lie against one of the panels 18 after which panel 16 is folded 180° over the end to lie against the inner faces of the other panel 18. This brings the intermediate side partial panels 17 against the inner faces of the outer side panels 12 (FIG. 4). Panels 13 are then folded downwardly to lie against the inner faces of the panels 12 and 17 on each side (FIG. 5), which brings the inner bottom half panels 14 flush against the bottom panel 11 with the long edges of the panels 14 butting against each other along the middle of the bottom (FIG. 6). It will be seen that the various handhole cutouts match to provide a handhole at each end of the box. FIGS. 7, 8 and 9 illustrate the positions of the various panels in the ends of the setup box.

When the metal reinforcing member 30 is to be included in the box to strengthen the rim of the box, such member is inserted before the inner panels are folded over the ends and sides.

Thus among others, the several aforementioned objects and advantages are most effectively attained. Although a somewhat preferred embodiment of the invention has been disclosed and described in detail herein, it should be understood that this invention is in no sense limited thereby and its scope is to be determined by that of the appended claims.

Having thus described the invention, what is claimed is:

1. A four sided box formed from a generally rectangular blank of sheet material cut, scored and folded

into said box having a bottom, two opposite side walls and two opposite end walls; each end wall comprising an outer end panel hinged to the bottom, an inner end panel hinged to the top of the outer end panel, a first intermediate end partial panel hinged to a side edge of one of the side walls, a first intermediate full panel hinged to the top of the first intermediate end partial panel and folded outwardly to lie flat against the outer face of the said first partial panel, a second intermediate end partial panel hinged to the opposite side edge of the other of the side walls, and a second intermediate full panel hinged to the top of the second intermediate end partial panel and folded inwardly to lie flat against the inner face of the said second partial panel, the sum of the widths of the said partial panels not exceeding the width of the end wall, said intermediate panels being positioned between the inner and outer end panels, the said panels of each end wall being cut out to provide a handhole for carrying the box; each side wall comprising an outer side panel hinged to the bottom, an inner side panel hinged to the top of the said outer side panel, and side partial panels each hinged to the side edge of an inner end panel, the inner and outer side panels being superimposed with the side partial panels positioned therebetween; the bottom comprising inner bottom partial panels hinged to the bottom edges of the opposite inner side panels, the sum of the widths of the said inner bottom partial panels being approximately equal to the width of the bottom, whereby the said inner bottom partial panels will butt along their facing edges.

2. A blank made from a generally rectangular sheet adapted for folding into a four sided box having a bottom, two opposite side walls and two opposite end walls comprising generally parallel horizontal and vertical score lines defining the bottom and two opposite outer side panels hinged to the bottom and adapted to form

the opposite side walls, outer end panels hinged to the ends of the bottom along the said vertical score lines, inner end panels hinged to the said outer end panels along score lines parallel to the said vertical score lines, intermediate end partial panels hinged to the side walls along the said vertical score lines, the sum of the widths of the said partial panels from the said vertical score lines at each end not exceeding the width of the said end, and intermediate end full panels hinged to the intermediate end full panels hinged to the intermediate end partial panels along score lines which are normal to the said vertical score lines and opposite the outer end panels, whereby the said blank can be set up to form a box having the said end walls formed of five superimposed panels with the intermediate panels interposed between the inner and outer end panels.

3. The blank of claim 2 in which an inner side panel is hinged to each outer side panel along a score line generally parallel to the score line connecting the outer side panel to the bottom, whereby the inner and outer side panels can be superimposed in the setup box to form the said opposite side walls.

4. The blank of claim 3 in which an inner bottom partial panel is hinged to each inner side panel along a score line generally parallel to the score line connecting the inner and outer side panels, the sum of the widths of the said inner bottom partial panels being approximately equal to the width of the bottom, whereby the said inner bottom partial panels will butt along their facing edges in the setup box.

5. The blank of claim 3 in which side partial panels are hinged to the side edges of an inner end panel whereby the said side partial panels can be interposed between the said inner and outer side panels in the setup box.

* * * * *

40

45

50

55

60

65