

(19)



(11)

EP 3 673 106 B1

(12)

EUROPEAN PATENT SPECIFICATION

(45) Date of publication and mention of the grant of the patent:
04.01.2023 Bulletin 2023/01

(51) International Patent Classification (IPC):
D06F 39/02^(2006.01) D06F 39/08^(2006.01)

(21) Application number: **17768003.0**

(52) Cooperative Patent Classification (CPC):
D06F 39/022; D06F 39/088

(22) Date of filing: **24.08.2017**

(86) International application number:
PCT/EP2017/071275

(87) International publication number:
WO 2019/037851 (28.02.2019 Gazette 2019/09)

(54) **A WASHING MACHINE HAVING AN IMPROVED TREATMENT AGENT FEEDING AND DOSING DEVICE**

WASCHMASCHINE MIT VERBESSERTER BEHANDLUNGSMITTELZUFÜHR- UND DOSIERVORRICHTUNG

MACHINE À LAVER AVEC DISPOSITIF D'ALIMENTATION ET DE DOSAGE D'AGENT DE TRAITEMENT AMÉLIORÉ

(84) Designated Contracting States:
AL AT BE BG CH CY CZ DE DK EE ES FI FR GB GR HR HU IE IS IT LI LT LU LV MC MK MT NL NO PL PT RO RS SE SI SK SM TR

- **TATAR, Hakan**
34950 Istanbul (TR)
- **ERDEM, Ilkan**
34950 Istanbul (TR)
- **CORCHES, Florin Horea**
34950 Istanbul (TR)

(43) Date of publication of application:
01.07.2020 Bulletin 2020/27

(73) Proprietor: **Arçelik Anonim Sirketi**
34445 Istanbul (TR)

(56) References cited:
EP-A1- 1 959 045 EP-A1- 2 508 667
EP-A1- 3 041 982 WO-A1-2017/114637
CN-U- 205 313 863 DE-B3-102007 048 199

(72) Inventors:
• **GERMIYANLIOGLU, Caner**
34950 Istanbul (TR)

EP 3 673 106 B1

Note: Within nine months of the publication of the mention of the grant of the European patent in the European Patent Bulletin, any person may give notice to the European Patent Office of opposition to that patent, in accordance with the Implementing Regulations. Notice of opposition shall not be deemed to have been filed until the opposition fee has been paid. (Art. 99(1) European Patent Convention).

Description

[0001] The present invention relates to a washing machine having an improved detergent feeding device.

[0002] It is well-known that washing machine users increasingly prefer to use liquid treatment agents, such as detergents and fabric softeners, for washing their laundry. Users are also encouraged to use liquid treatment agents as these are more environmentally friendly. As laundry detergents are being produced in liquid form and widely used at homes, there is a need for washing machines that have the capability to store and provide suitable dosages of said liquid treatment agents.

[0003] Washing machines having systems for providing doses of liquid treatment agents are currently available on the market. These systems typically comprise tanks containing liquid treatment devices, a user interface to allow users to fill these tanks (such as drawers, lids, etc.) and a hydraulic device to transfer the correct amount of treatment agent to the washing area (laundry drum) at the correct time.

[0004] There are many methods available to realize dosing of liquid treatment agents, namely, transferring said treatment agent from storage tanks to the laundry drum of washing machines. Some exemplary methods include submersible pumps placed inside the tanks and hydraulic lines that operate by creating a vacuum to suck the liquid treatment device from the storage tank and transfer it to the laundry drum.

[0005] Some of the most important features of a dosing system are control of dosage amount, dosage timing, washing of dosage area by water to transfer the treatment agent to the laundry drum and detection of the fullness of the storage tanks.

[0006] The dosage system requires power in order to function and provide controlled dosing. Generally the required power is provided by the washing machine; therefore it is not possible to take the dosage system which is positioned inside the treatment agent storage out of the washing machine. For this reason, it is not possible to clean the treatment agent storage reservoirs of integrated systems.

[0007] Among others, a prior art publication in the technical field of the invention may be referred to as EP2428607, which discloses a water-carrying household appliance. The appliance comprises a housing, a treatment chamber and an automatic dosing system within the housing. The automatic dosing system has a reservoir for a liquid treatment agent and a delivery pump within the reservoir. The household appliance further includes a controller to control the automatic dosing system. The power required for the operation of the invention is provided hydraulically. Other prior art publications may be referred to as CN102409515 and EP2048276.

[0008] A prior art publication in the technical filed of invention may be referred as WO2017114637, which discloses a washing machine that performs the cleaning agent dosing process with low cost.

[0009] The present invention, on the other hand, addresses the situation where the desired amount of treatment agent can be transferred to the laundry drum. In contrast to currently available systems, dosing is facilitated not by pumps but by a wheel system. Said wheel system is mounted onto the detergent drawer. When the detergent drawer is pulled out, the dosing system can also be taken out of the washing machine.

[0010] The present invention provides a dosing unit for a laundry treatment machine as provided by the characterizing features defined in Claim 1.

[0011] Primary object of the present invention is to provide a dosing unit for a laundry treatment machine by which desired amount of treatment agent can be transferred to laundry drum without dissipating active power.

[0012] The present invention proposes a treatment agent dosing system for a laundry treatment machine, said treatment agent dosing system transferring liquid treatment agents in predetermined quantities from a plurality of treatment agent tanks to a washing liquid reservoir.

[0013] The control valves at the backs of the treatment agent tanks prevent liquid treatment agents from spilling out of the treatment agent tanks while the treatment agent drawer is in open position and allow the liquid treatment agent to be transferred to the treatment agent reservoir when the drawer is in closed position. When the treatment agent drawer is in closed position, the conducting pins inside the treatment agent reservoirs detect the presence and type of liquid treatment agents contained therein. Information on whether the treatment agent tanks are filled and if so what kind of fluid is contained therein can be detected through conductivity information obtained from the pins. Based on the type of liquid, the steps of which treatment agent tanks will provide dosage at what point in the washing program can be adjusted and the user will be reminded what liquid is in which tank.

[0014] In the relevant step of the washing program (main washing or softening), the peristaltic pump will be activated whereby the relevant liquid can be transferred from the treatment agent reservoir to the washing liquid reservoir. The treatment agent tanks and reservoirs are in constant fluid communication when the treatment agent drawer is in closed position.

[0015] A venturi tube portion is added to said washing water line by placing a constricted section along said line. The treatment agent line is directly connected to said constricted section. In this manner, negative pressure gradient across the venturi tube portion is used to ease the movement of treatment agents across the line. Build-up of treatment agents in the treatment agent line is prevented.

[0016] Accompanying drawings are given solely for the purpose of exemplifying a dosing unit for a laundry treatment machine, whose advantages over prior art were outlined above and will be explained in brief hereinafter.

[0017] The drawings are not meant to delimit the scope of protection as identified in the Claims, nor should they

be referred to alone in an effort to interpret the scope identified in said Claims without recourse to the technical disclosure in the description of the present invention. The drawings are only exemplary in the sense that they do not necessarily reflect the actual dimensions and relative proportions of the respective components of the system.

Fig. 1 demonstrates a perspective view of a treatment agent drawer having a treatment agent dosing system according to the present invention.

Fig. 2 demonstrates a top view of a treatment agent drawer having a treatment agent dosing system according to the present invention.

Fig. 3 demonstrates a sectional view of a treatment agent drawer having a treatment agent dosing system taken along line 3-3 of Fig. 2.

Fig. 4 demonstrates a bottom view of a treatment agent dosing system and treatment agent reservoirs according to the present invention.

Fig. 5 demonstrates a side view of a treatment agent dosing system and treatment agent reservoirs according to the present invention.

Fig. 6 demonstrates another side view a treatment agent dosing system and treatment agent reservoirs according to the present invention.

[0018] The following numerals are assigned to different part numbers used in the detailed description:

- 1) Treatment agent dosing system
- 2) Treatment agent drawer
- 3) Treatment agent tank
- 4) Treatment agent reservoir
- 5) Washing liquid reservoir
- 6) Treatment agent wheel
- 7) Water wheel
- 8) Water line
- 9) Venturi tube portion
- 10) Water inlet
- 11) Treatment agent line
- 12) Washing water line
- 13) Water reservoir

[0019] The present invention proposes a treatment agent dosing system (1) for a laundry treatment appliance such as washing machine; said dosing system comprising a wheel system having a treatment agent wheel (6) and a water wheel (7) operated to effect transfer of different treatment agents to the drum of the washing machine. According to the present invention, the treatment agent dosing system (1) facilitates dosing via mains water circulated to transfer treatment agents to the laundry drum.

[0020] Liquid treatment agents are transferred from a number of treatment agent tanks (3) to a washing liquid reservoir (5) in specified quantities as necessitated by the respective treatment program. For this purpose, it is required that water in a washing water line (12) leading to said washing liquid reservoir (5) be circulated in order for the liquid therein to be washed out. Control valves (not shown) placed at the rear portions of the treatment agent tanks (3) in the treatment agent drawer (2) typically allow the treatment agent tanks (3) to act as closed receptacle when the treatment agent drawer (2) is pulled out. In other words, placement of the treatment agent drawer (2) in its operative position provides that liquid communication is established between treatment agent tanks (3) and treatment agent reservoirs (4) through control valves. Treatment agent reservoirs (4) comprise a treatment agent wheel (6) in order for transferring treatment agents to said washing liquid reservoir (5) as will be delineated below in more detail.

[0021] When the treatment agent drawer (2) is pushed into the washing machine to the closed position, the control valves are joined to the pipes inside the treatment agent reservoirs (4). Conducting pins (not shown) placed in the pipes open the control valves and the liquid inside the tanks are transferred to the treatment agent reservoirs (5). Treatment agent wheels (6) disposed in said treatment agent reservoirs (4) are driven by respective water wheels (7) disposed in water reservoirs (13) to transfer liquid treatment agents from the treatment agent reservoir (4) such that the agents will be mixed with water and circulated to the washing liquid reservoir (5) and the drum as will be explained hereinafter. Water reservoir (13) and neighboring treatment agent reservoir (4) are separated by a sealing means to prevent mixture of the liquid treatment agents with water at this stage.

[0022] When the treatment agent drawer (2) is in the closed position, conductor pins placed inside the treatment agent reservoirs (4) detect the presence of liquid in the treatment agent reservoir (4) coming from the tanks. If the treatment agent drawer (2) is pushed in while the treatment agent tanks (3) are empty, the reservoirs will not be filled and the pins will transmit that the treatment agent tanks (3) are empty to the control system.

[0023] Additionally, said conducting pins transmit conductivity information, which allows the system to distinguish between types of treatment agents, such as detergents and fabric softeners. In this manner, information on which treatment agent tank (3) contains which type of treatment agent can be conveyed to the user/control unit and, if necessary, the tasks of the valves to operate the treatment agent wheels for liquid detergent and fabric softener can be switched by the dosing algorithm.

[0024] After entering the washing machine from a respective water inlet (10), the water facilitating the operation of the wheel system passes through a water line (8) having preferably a telescopic structure and controlled by valves to turn the respective water wheels (7). Using the hydraulic energy of water, treatment agent

wheels (6) connected to and sharing a shaft with the rotating water wheels (7) are rotated. In this manner, the liquid treatment agents are pumped into the washing liquid reservoir (5), wherefrom they will be transferred to the drum.

[0025] A treatment agent line (11) (best seen in Fig. 6) in communication with said treatment agent reservoir (4) is directly connected to a venturi tube portion (9) on a washing water line (12). More particularly, said water wheel (7) is rotated by a predefined amount of water (as controlled by respective valve members) to simultaneously drive said treatment agent wheel (6), the treatment agent and water respectively circulates through a treatment agent line (11) and the washing water line (12) such that treatment agent line (11) directly opens to said venturi tube portion (9) of the washing water line (12) thanks to which water and treatment agent are mixed with each other. The negative pressure gradient across the venturi tube portion (9) allows the treatment agents to move easily and prevents buildup of treatment agents in the treatment agent line (11).

[0026] After dosing is completed, water will be received from an additional douching system so that the dosed liquid in the washing liquid reservoir (5) will be washed into the laundry drum.

[0027] According to the invention, the treatment agent drawer (2) containing treatment agent tanks (3) for storing liquid treatment agents also contains a chamber for powdered detergents, which can be directly mixed with water through a respective inlet and also directly transferred to said washing liquid reservoir (5).

[0028] The water inlet (10) providing water to the water wheel (7) is separated by O-ring seals. Wheel systems (6, 7) can be taken out of the washing machine along with the treatment agent drawer (2). When the treatment agent reservoir (4) is pulled out, the mounted wheel systems (6, 7) can also be taken out. In this manner, the treatment agent reservoir (4) can be easily cleaned by the user. The water inlet (10) can be alternatively placed on the same horizontal axis along said water line (8). In such a case, a telescopic design that is easily disassembled can be used. According to a further alternative embodiment, the water inlet (10) can be placed on the same vertical axis leading to the water reservoir (13).

[0029] The water line (8) connected to the water inlet valve is preferably configured to have a 90° elbow. The water line (8) has a larger cross section than the treatment agent line (11).

[0030] Water entering the wheel system from the water inlet (10) is conveniently transferred to said wheel system via telescopic water channels that can easily be disassembled.

[0031] In a nutshell, the present invention proposes a treatment agent dosing system (1) for a laundry treatment machine, said treatment agent dosing system (1) transferring liquid treatment agents in predetermined quantities from a plurality of treatment agent tanks (3) to a washing liquid reservoir (5).

[0032] In one aspect of the present invention, said treatment agent dosing system (1) comprises a first rotatable element in the form of a treatment agent wheel (6) in a treatment agent reservoir (4) and a second rotatable element in the form of a water wheel (7) in a water reservoir (13), said treatment agent wheel (6) transferring treatment agents from said treatment agent reservoir (4) through a treatment agent line (11) to a washing water line (12) and said water wheel (7) transferring water from said water reservoir (13) to said washing water line (12).

[0033] In a further aspect of the present invention, said treatment agent line (11) in communication with said treatment agent reservoir (4) is directly connected to a venturi tube portion (9) of said washing water line (12) such that treatment agents and water circulated in fluidly isolated manner are first mixed at said venturi tube portion (9) of said washing water line (12).

[0034] In a further aspect of the present invention, said treatment agent reservoir (4) is in fluid communication with a respective treatment agent tank (3) in the closed operational position of the treatment agent drawer (2) containing said treatment agent tank (3).

[0035] In a further aspect of the present invention, said treatment agent wheel (6) and water wheel (7) are in fluid communication with isolated water and treatment agent lines (respectively 8, 11).

[0036] In a further aspect of the present invention, said treatment agent reservoir (4) and water reservoir (13) are fluidly isolated from each other by a sealing means having an opening to accommodate a common shaft in connection with said treatment agent wheel (6) and said water wheel (7).

[0037] In a further aspect of the present invention, conductor pins inside said treatment agent reservoirs (4) detect the presence of liquid in the treatment agent reservoir (4) coming from the treatment agent tanks.

[0038] In a further aspect of the present invention, said conducting pins transmit conductivity information to distinguish between types of treatment agents in the form of detergents or fabric softeners and information on which treatment agent tank (3) contains which type of treatment agent is transmitted such that tasks of control valves to operate water wheels (7) in association with respective treatment agent wheels (6) for liquid detergent and fabric softener is switchable.

[0039] In a further aspect of the present invention, said treatment agent drawer (2) containing treatment agent tanks (3) for storing liquid treatment agents also contains a chamber for powdered detergents which is directly mixed with water through a dedicated water inlet and directly transferred to said washing liquid reservoir (5).

[0040] In a further aspect of the present invention, said treatment agent drawer (2) is integrally configured with said treatment agent dosing system (1) and is integrally removable together with the treatment agent dosing system (1) having said treatment agent reservoir (4) and said water reservoir (13).

[0041] In a further aspect of the present invention, said

water line (8) has a larger cross section than the treatment agent line (11).

[0042] In a further aspect of the present invention, said treatment agent line (11) connects to the venturi tube portion (9) of the washing water line (12) in perpendicular configuration.

[0043] The present invention is devised under the recognition that the treatment agents are needed to be transferred to the washing liquid reservoir (5)/drum. A venturi tube portion (9) more effectively fulfills this function. The water used in the wheel system is passed through said venturi tube. In this manner, the water used in the wheel system is reused, buildup of treatment agents on the treatment agent line is prevented and treatment agents will be washed more efficiently. As the dosage system can be taken out of the washing machine, it can easily be filled and emptied by the user. Also the treatment agent reservoirs (4) can be easily cleaned.

Claims

1. A treatment agent dosing system (1) for a laundry treatment machine, said treatment agent dosing system (1) transferring liquid treatment agents in predetermined quantities from a plurality of treatment agent tanks (3) to a washing liquid reservoir (5) **characterized in that**

the treatment agent dosing system (1) comprises a first rotatable element in the form of a treatment agent wheel (6) in a treatment agent reservoir (4) and a second rotatable element in the form of a water wheel (7) in a water reservoir (13), a water line (8) controlled by valves to turn the respective water wheel (7), wherein, using the hydraulic energy of water, the treatment agent wheel (6) connected to and sharing a shaft with the rotating water wheel (7) is rotated, said treatment agent wheel (6) transferring treatment agents from said treatment agent reservoir (4) through a treatment agent line (11) to a washing water line (12) and said water wheel (7) transferring water from the water reservoir (13) to the washing water line (12) and, the treatment agent line (11) in communication with the treatment agent reservoir (4) is directly connected to a venturi tube portion (9) of said washing water line (12) such that treatment agents and water circulated in fluidly isolated manner are first mixed at said venturi tube portion (9) of the washing water line (12).

2. A treatment agent dosing system (1) as in Claim 1, **characterized in that** the treatment agent reservoir (4) is in fluid communication with a respective treatment agent tank (3) in the closed operational position of a treatment agent drawer (2) containing said treat-

ment agent tank (3).

3. A treatment agent dosing system (1) as in Claim 1, **characterized in that** the treatment agent reservoir (4) and water reservoir (13) are fluidly isolated from each other by a sealing means having an opening to accommodate a common shaft in connection with said treatment agent wheel (6) and said water wheel (7).
4. A treatment agent dosing system (1) as in Claim 1, **characterized in that** conductor pins disposed inside the treatment agent reservoirs (4) detect the presence of liquid in the treatment agent reservoir (4) coming from the treatment agent tanks.
5. A treatment agent dosing system (1) as in Claim 4, **characterized in that** the conductor pins transmit conductivity information to distinguish between types of treatment agents in the form of detergents or fabric softeners and information on which treatment agent tank (3) contains which type of treatment agent is transmitted such that tasks of control valves to operate water wheels (7) in association with respective treatment agent wheels (6) for liquid detergent and fabric softener are switchable.
6. A treatment agent dosing system (1) as in Claim 1, **characterized in that** a treatment agent drawer (2) containing treatment agent tanks (3) for storing liquid treatment agents also contains a chamber for powdered detergents which is directly mixed with water through a dedicated water inlet and directly transferred to the washing liquid reservoir (5).
7. A treatment agent dosing system (1) as in Claim 1, **characterized in that** a treatment agent drawer (2) is integrally configured with said treatment agent dosing system (1) and is integrally removable together with the treatment agent dosing system (1) having said treatment agent reservoir (4) and said water reservoir (13).
8. A treatment agent dosing system (1) as in Claim 1, **characterized in that** the water line (8) has a larger cross section than the treatment agent line (11).
9. A treatment agent dosing system (1) as in Claim 1, **characterized in that** said treatment agent line (11) connects to the venturi tube portion (9) of the washing water line (12) in perpendicular configuration.
10. A washing machine comprising the treatment agent dosing system (1) as in any preceding Claim.

Patentansprüche

1. Ein Behandlungsmittel-Dosiersystem (1) für eine Wäschebehandlungsmaschine, wobei das Behandlungsmittel-Dosiersystem (1) flüssige Behandlungsmittel in vorbestimmten Mengen aus mehreren Behandlungsmittelreservoirs (3) in einen Waschflüssigkeitsbehälter (5) überführt, **ist dadurch gekennzeichnet, dass** das Behandlungsmittel-Dosiersystem (1) ein erstes rotierbares Element in Form eines Behandlungsmittelrades (6) in einem Behandlungsmittelreservoir (4) und ein zweites rotierbares Element in Form eines Wasserrades (7) in einem Wasserreservoir (13) aufweist, eine durch Ventile gesteuerte Wasserleitung (8) zum Drehen des jeweiligen Wasserrads (7), wobei unter Verwendung der hydraulischen Energie von Wasser das Behandlungsmittelrad (6), das mit dem rotierenden Wasserrad (7) verbunden ist und eine Welle mit ihm teilt, gedreht wird, wobei das Behandlungsmittelrad (6) Behandlungsmittel aus dem Behandlungsmittelreservoir (4) durch eine Behandlungsmittelleitung (11) zu einer Waschwasserleitung (12) überträgt und das Wasserrad (7) Wasser aus dem Wasserreservoir (13) zur Waschwasserleitung (12) überträgt und dadurch, dass die Behandlungsmittelleitung (11) in Verbindung mit dem Behandlungsmittelreservoir (4) direkt mit einem Venturi-Rohrabschnitt (9) der Waschwasserleitung (12) verbunden ist, sodass das Behandlungsmittel und strömungs isoliert umgewälztes Wasser zunächst an dem Venturi-Rohrabschnitt (9) der Waschwasserleitung (12) gemischt werden.
2. Ein Behandlungsmittel-Dosiersystem (1), wie in Anspruch 1 aufgeführt, **ist dadurch gekennzeichnet, dass** das Behandlungsmittelreservoir (4) in der geschlossenen Betriebsstellung einer den Behandlungsmittelreservoir (3) enthaltenden Behandlungsmittelschublade (2) mit einem jeweiligen Behandlungsmittelreservoir (3) in Fluidverbindung steht.
3. Ein Behandlungsmittel-Dosiersystem (1), wie in Anspruch 1 aufgeführt, **ist dadurch gekennzeichnet, dass** das Behandlungsmittelreservoir (4) und das Wasserreservoir (13) durch ein Dichtungsmittel mit einer Öffnung zur Aufnahme einer gemeinsamen Welle in Verbindung mit dem Behandlungsmittelrad (6) und dem Wasserrad (7) fluidisch voneinander getrennt sind.
4. Ein Behandlungsmittel-Dosiersystem (1), wie in Anspruch 1 aufgeführt, **ist dadurch gekennzeichnet, dass** innerhalb der Behandlungsmittelreservoirs (4) angeordnete Leiterstifte das Vorhandensein von aus den Behandlungsmittelreservoirs stammender Flüssigkeit im Behandlungsmittelreservoir (4) erfassen.
5. Ein Behandlungsmittel-Dosiersystem (1), wie in Anspruch 4 aufgeführt, **ist dadurch gekennzeichnet, dass** die Leiterstifte Leitfähigkeitsinformationen zur Unterscheidung von Behandlungsmittelarten in Form von Waschmitteln oder Weichspülern übertragen und Informationen darüber, welcher Behandlungsmittelreservoir (3) welche Art von Behandlungsmittel enthält, derart übertragen werden, dass Aufgaben von Steuerventilen zur Betätigung von Wasserrädern (7) übertragen werden und so in Zuordnung zu entsprechenden Behandlungsmittelrädern (6) für Flüssigwaschmittel und Weichspüler schaltbar sind.
6. Ein Behandlungsmittel-Dosiersystem (1), wie in Anspruch 1 aufgeführt, **ist dadurch gekennzeichnet, dass** eine Behandlungsmittelschublade (2) mit Behandlungsmittelreservoirs (3) zur Bevorratung flüssiger Behandlungsmittel auch eine Kammer für pulverförmige Reinigungsmittel enthält, die über einen eigenen Wasserzulauf direkt mit Wasser vermischt und direkt in den Waschflüssigkeitsbehälter (5) überführt werden.
7. Ein Behandlungsmittel-Dosiersystem (1), wie in Anspruch 1 aufgeführt, **ist dadurch gekennzeichnet, dass** eine Behandlungsmittelschublade (2) integral mit dem Behandlungsmittel-Dosiersystem (1) ausgebildet ist und zusammen mit dem Behandlungsmittel-Dosiersystem (1) mit dem Behandlungsmittelreservoir (4) und dem Wasserreservoir (13) integral entnehmbar ist.
8. Ein Behandlungsmittel-Dosiersystem (1), wie in Anspruch 1 aufgeführt, **ist dadurch gekennzeichnet, dass** die Wasserleitung (8) einen größeren Querschnitt als die Behandlungsmittelleitung (11) aufweist.
9. Ein Behandlungsmittel-Dosiersystem (1), wie in Anspruch 1 aufgeführt, **ist dadurch gekennzeichnet, dass** die Behandlungsmittelleitung (11) in senkrechter Konfiguration an den Venturi-Rohrabschnitt (9) der Waschwasserleitung (12) anschließt.
10. Eine Waschmaschine umfasst das Behandlungsmittel-Dosiersystem (1) nach einem der vorhergehenden Ansprüche.

Revendications

1. Système de dosage d'agent de traitement (1) pour une machine de traitement du linge, ledit système de dosage d'agent de traitement (1) transférant des agents de traitement liquides en quantités prédéterminées depuis une pluralité de réservoirs d'agent de traitement (3) vers un réservoir de liquide de lavage (5), **caractérisé en ce que**

- le système de dosage d'agent de traitement (1) comprend un premier élément rotatif sous la forme d'une roue d'agent de traitement (6) dans un réservoir d'agent de traitement (4) et un second élément rotatif sous la forme d'une roue à eau (7) dans un réservoir d'eau (13), une ligne d'eau (8) commandée par des vannes pour faire tourner la roue à eau respective (7), dans lequel en utilisant l'énergie hydraulique de l'eau, la roue d'agent de traitement (6) reliée à et partageant un arbre avec la roue d'eau rotative (7) est mise en rotation, ladite roue d'agent de traitement (6) transférant des agents de traitement dudit réservoir d'agent de traitement (4) à travers une ligne d'agent de traitement (11) à une ligne d'eau de lavage (12) et ladite roue d'eau (7) transférant de l'eau du réservoir d'eau (13) à la ligne d'eau de lavage (12) et, la ligne d'agent de traitement (11) en communication avec le réservoir d'agent de traitement (4) est directement connectée à une partie de tube venturi (9) de ladite ligne d'eau de lavage (12) de sorte que les agents de traitement et l'eau circulant de manière isolée du point de vue fluïdique sont d'abord mélangés au niveau de ladite partie de tube venturi (9) de la ligne d'eau de lavage (12).
2. Système de dosage d'agent de traitement (1) selon la déclaration 1, **caractérisé en ce que** le réservoir d'agent de traitement (4) est en communication fluïdique avec un réservoir d'agent de traitement respectif (3) dans la position opérationnelle fermée d'un tiroir d'agent de traitement (2) contenant ledit réservoir d'agent de traitement (3).
 3. Système de dosage d'agent de traitement (1) selon la déclaration 1, **caractérisé en ce que** le réservoir d'agent de traitement (4) et le réservoir d'eau (13) sont isolés fluïdiquement l'un de l'autre par un moyen d'étanchéité ayant une ouverture pour recevoir un arbre commun en liaison avec ladite roue d'agent de traitement (6) et ladite roue d'eau (7).
 4. Système de dosage d'agent de traitement (1) selon la déclaration 1, **caractérisé en ce que** des broches conductrices disposées à l'intérieur des réservoirs d'agent de traitement (4) détectent la présence de liquide dans le réservoir d'agent de traitement (4) provenant des réservoirs d'agent de traitement.
 5. Système de dosage d'agent de traitement (1) tel que dans la déclaration 4, **caractérisé en ce que** les broches conductrices transmettent des informations de conductivité pour distinguer entre les types d'agents de traitement sous la forme de détergents ou d'adoucisseurs de tissu et des informations sur quel réservoir d'agent de traitement (3) contient quel type d'agent de traitement sont transmises de sorte que les tâches des vannes de commande pour actionner les roues à eau (7) en association avec les roues d'agent de traitement respectives (6) pour le détergent liquide et l'adoucisseur de tissu sont commutables.
 6. Système de dosage d'agent de traitement (1) tel que dans la déclaration 1, **caractérisé en ce qu'un** tiroir d'agent de traitement (2) contenant des réservoirs d'agent de traitement (3) pour stocker des agents de traitement liquides contient également une chambre pour des détergents en poudre qui sont directement mélangés avec de l'eau par une entrée d'eau dédiée et directement transférés vers le réservoir de liquide de lavage (5).
 7. Système de dosage d'agent de traitement (1) selon la déclaration 1, **caractérisé en ce qu'un** tiroir d'agent de traitement (2) est configuré intégralement avec ledit système de dosage d'agent de traitement (1) et est intégralement amovible avec le système de dosage d'agent de traitement (1) ayant ledit réservoir d'agent de traitement (4) et ledit réservoir d'eau (13).
 8. Système de dosage d'agent de traitement (1) selon la déclaration 1, **caractérisé en ce que** la conduite d'eau (8) a une section transversale plus grande que la conduite d'agent de traitement (11).
 9. Système de dosage d'agent de traitement (1) selon la déclaration 1, **caractérisé en ce que** ladite ligne d'agent de traitement (11) se raccorde à la partie de tube venturi (9) de la ligne d'eau de lavage (12) en configuration perpendiculaire.
 10. Une machine à laver comprenant le système de dosage d'agent de traitement (1) comme dans toute déclaration précédente.

Fig. 1

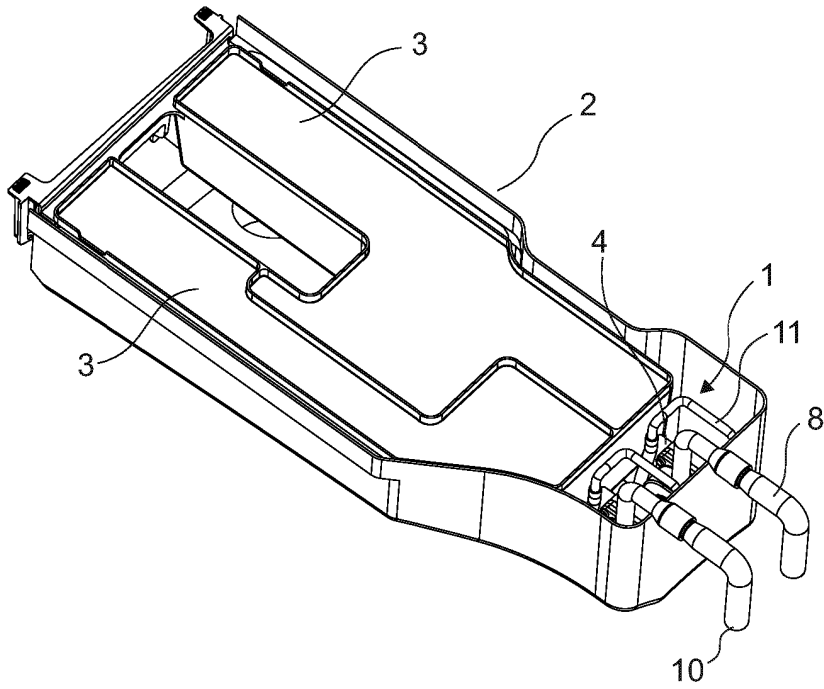

Fig. 2

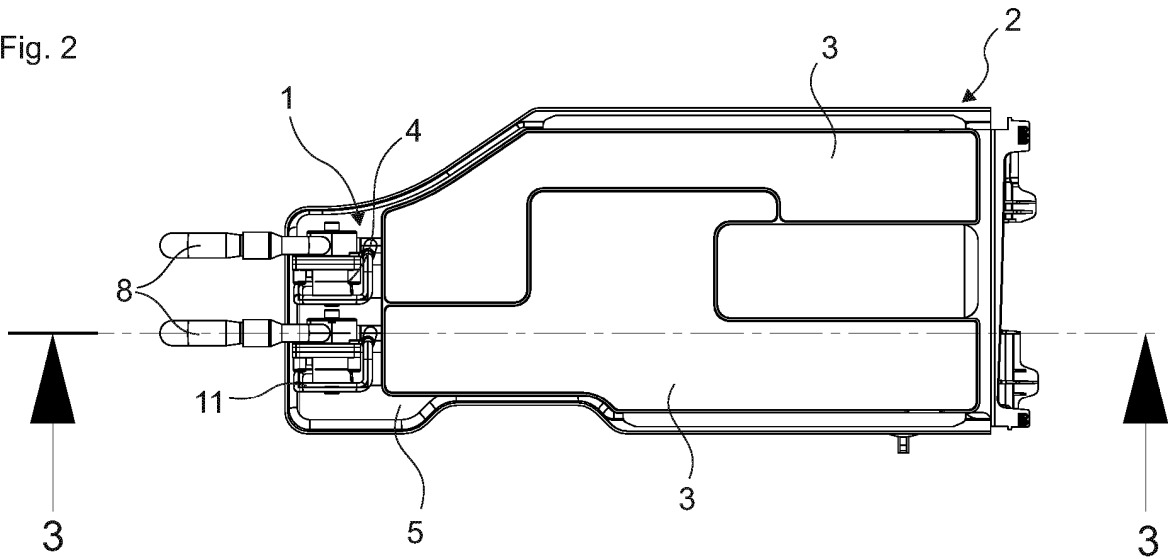

Fig. 3

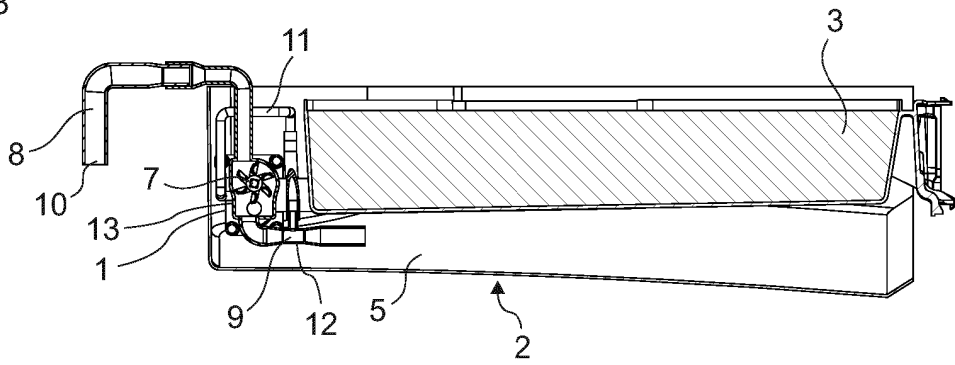

Fig. 4

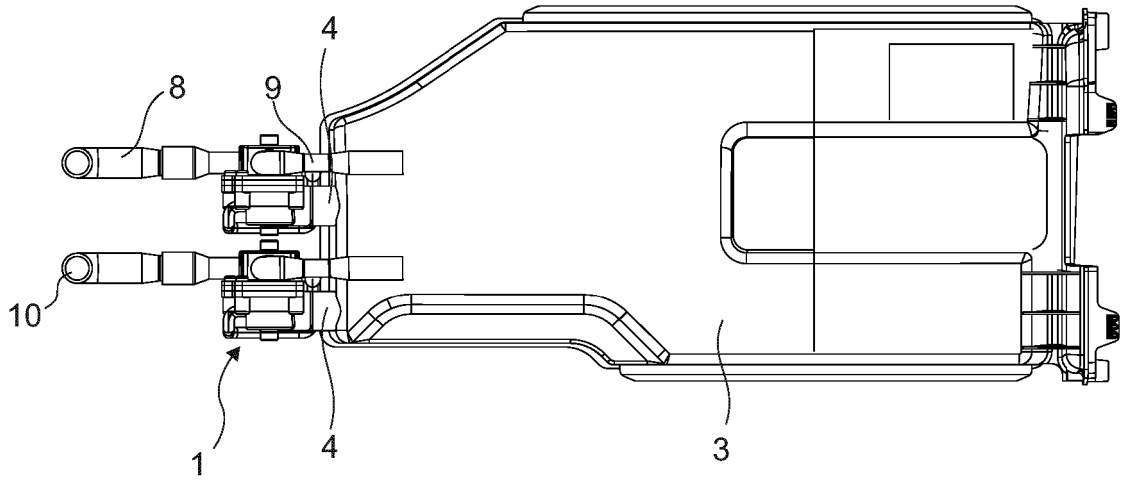

Fig. 5

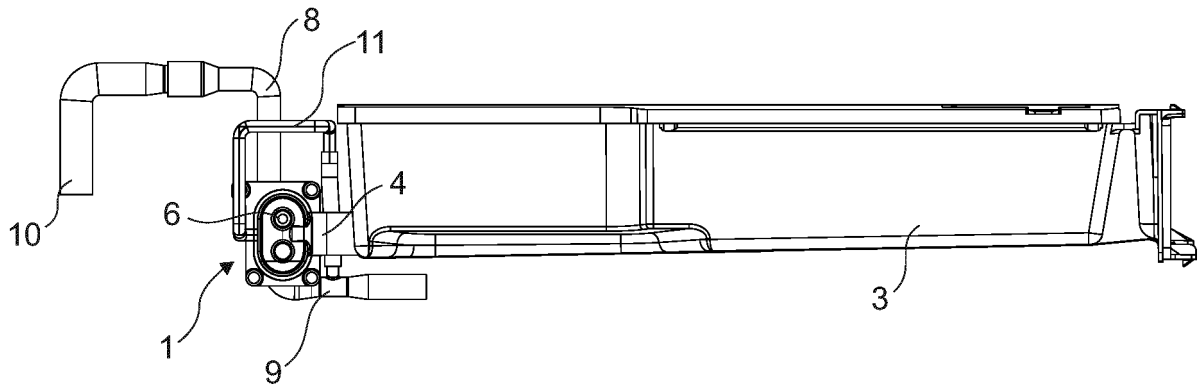
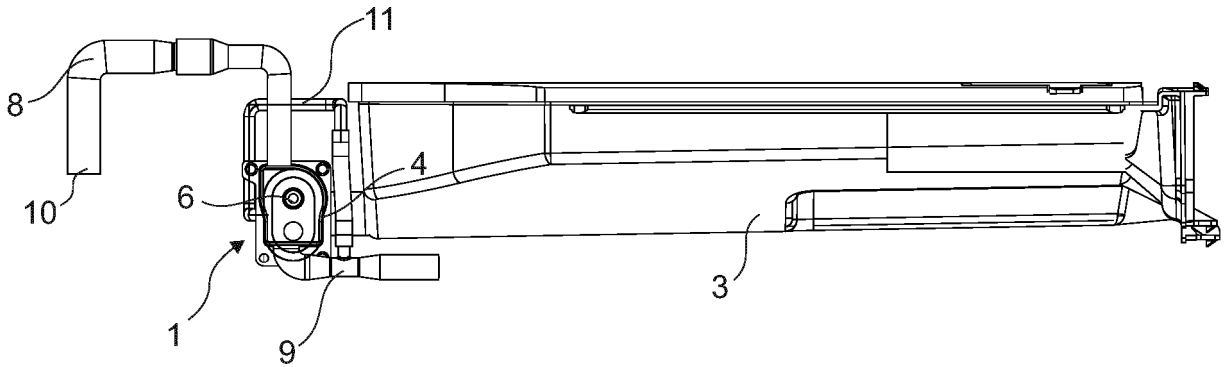

Fig. 6



REFERENCES CITED IN THE DESCRIPTION

This list of references cited by the applicant is for the reader's convenience only. It does not form part of the European patent document. Even though great care has been taken in compiling the references, errors or omissions cannot be excluded and the EPO disclaims all liability in this regard.

Patent documents cited in the description

- EP 2428607 A [0007]
- CN 102409515 [0007]
- EP 2048276 A [0007]
- WO 2017114637 A [0008]