

(12) **United States Patent**
Kim et al.

(10) **Patent No.:** **US 11,328,186 B2**
(45) **Date of Patent:** **May 10, 2022**

(54) **DEVICE AND METHOD FOR PROCESSING METADATA**

(71) Applicant: **Samsung Electronics Co., Ltd.**,
Suwon-si (KR)

(72) Inventors: **Woo-Chan Kim**, Seoul (KR);
Jun-Seok Heo, Seoul (KR)

(73) Assignee: **Samsung Electronics Co., Ltd.**,
Suwon-si (KR)

(*) Notice: Subject to any disclaimer, the term of this patent is extended or adjusted under 35 U.S.C. 154(b) by 179 days.

(21) Appl. No.: **16/727,583**

(22) Filed: **Dec. 26, 2019**

(65) **Prior Publication Data**

US 2020/0134397 A1 Apr. 30, 2020

Related U.S. Application Data

(63) Continuation of application No. 16/426,650, filed on May 30, 2019, now Pat. No. 10,558,896, which is a
(Continued)

(30) **Foreign Application Priority Data**

Nov. 11, 2015 (KR) 10-2015-0158197

(51) **Int. Cl.**

G06K 9/62 (2006.01)

G06F 16/35 (2019.01)

(Continued)

(52) **U.S. Cl.**

CPC **G06K 9/6288** (2013.01); **G06F 16/00** (2019.01); **G06F 16/284** (2019.01); **G06F 16/35** (2019.01);

(Continued)

(58) **Field of Classification Search**

CPC G06F 16/00; G06F 16/284; G06F 16/35; G06F 16/58; G06F 16/5854;

(Continued)

(56) **References Cited**

U.S. PATENT DOCUMENTS

8,630,513 B2 1/2014 Gokturk et al.

8,750,557 B2 6/2014 Ghatore et al.

(Continued)

FOREIGN PATENT DOCUMENTS

CN 101149750 A 3/2008

CN 101459801 A 6/2009

(Continued)

OTHER PUBLICATIONS

Tousch Anne-Marie, et al., "Semantic Hierarchies for Image Annotation: A Suvey", Elsevier, Jun. 7, 2011, pp. 333-345, XP028388716, Palaiseau, France.

(Continued)

Primary Examiner — Mekonen T Bekele

(74) *Attorney, Agent, or Firm* — Jefferson IP Law, LLP

(57) **ABSTRACT**

A method and an electronic device are disclosed. The method includes obtaining an image, obtaining information of the image, obtaining content information of content included in the image, obtaining related information which relates to the image based on at least one of the information of the image and the content information, and classifying the image into at least one category based on a plurality of defined information/data elements and a relation among the information/data elements and metadata of the image.

20 Claims, 23 Drawing Sheets

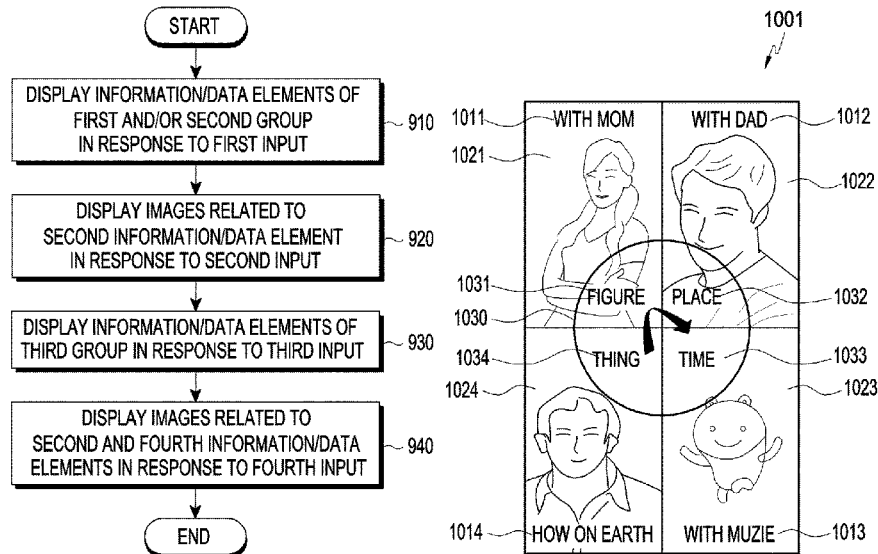

Related U.S. Application Data

continuation of application No. 16/287,417, filed on Feb. 27, 2019, now Pat. No. 10,360,479, which is a continuation of application No. 15/774,093, filed as application No. PCT/KR2016/012871 on Nov. 9, 2016, now Pat. No. 10,909,428.

(51) **Int. Cl.**

G06F 16/58 (2019.01)
G06F 16/28 (2019.01)
G06F 16/907 (2019.01)
G06F 16/00 (2019.01)
G06F 16/583 (2019.01)
G06T 1/00 (2006.01)

(52) **U.S. Cl.**

CPC **G06F 16/58** (2019.01); **G06F 16/5854** (2019.01); **G06F 16/907** (2019.01); **G06T 1/0007** (2013.01)

(58) **Field of Classification Search**

CPC ... G06F 16/907; G06K 9/6288; G06T 1/0007; G06T 7/0004; G06T 2207/10061; G06T 2207/20072; G06T 2207/20076; G06T 2207/20081; G06T 2207/30148; G06N 20/00

See application file for complete search history.

(56)

References Cited

U.S. PATENT DOCUMENTS

9,785,337 B2 10/2017 Seo et al.
 10,360,479 B2 7/2019 Kim et al.
 10,491,963 B1* 11/2019 Waggoner H04N 21/2541
 2006/0195361 A1* 8/2006 Rosenberg G06Q 30/0267
 705/14.52
 2007/0115373 A1* 5/2007 Gallagher G06F 16/58
 348/231.3
 2007/0136680 A1 6/2007 Skrenta
 2007/0174270 A1* 7/2007 Goodwin G06F 16/951
 2008/0256100 A1 10/2008 Van De Sluis et al.
 2008/0259170 A1 10/2008 Hatanaka
 2009/0148071 A1 6/2009 Ohwa et al.
 2009/0192967 A1* 7/2009 Luo G06N 20/00
 706/47
 2010/0134693 A1 6/2010 Lee et al.
 2010/0185664 A1* 7/2010 Baggott G06F 40/205
 707/769
 2010/0331016 A1* 12/2010 Dutton H04W 4/18
 455/456.3
 2011/0044563 A1 2/2011 Blose et al.
 2011/0085739 A1 4/2011 Zhang et al.
 2011/0317885 A1 12/2011 Leung et al.
 2012/0054140 A1* 3/2012 Shimizu G06N 5/02
 706/46
 2012/0207389 A1* 8/2012 Ghatore G06F 16/5846
 382/173
 2012/0304125 A1 11/2012 Gokturk et al.
 2013/0004082 A1* 1/2013 Kano G06T 5/002
 382/195
 2013/0083977 A1 4/2013 Jackson
 2013/0155063 A1 6/2013 Solem et al.
 2014/0026043 A1 1/2014 Takeuchi
 2014/0075393 A1 3/2014 Mei et al.
 2014/0122605 A1* 5/2014 Merom G06Q 10/10
 709/204

2014/0164974 A1 6/2014 Kim
 2014/0219517 A1 8/2014 Mishra et al.
 2014/0351709 A1 11/2014 Uno et al.
 2015/0007243 A1 1/2015 Kunkel et al.
 2015/0293942 A1 10/2015 Cady et al.
 2016/0196287 A1 7/2016 Cady et al.
 2016/0283519 A1 9/2016 Glasgow et al.
 2016/0316219 A1 10/2016 Yuan et al.
 2017/0124740 A1 5/2017 Campbell et al.
 2017/0132687 A1 5/2017 Kim et al.
 2017/0177731 A1 6/2017 Okayama et al.
 2017/0286456 A1 10/2017 Wenzel et al.
 2018/0267998 A1 9/2018 Albouyeh et al.
 2019/0197365 A1 6/2019 Kim et al.
 2020/0210490 A1* 7/2020 Hutchins G06K 9/00979

FOREIGN PATENT DOCUMENTS

CN 101571875 A 11/2009
 CN 101772950 A 7/2010
 CN 102422286 A 4/2012
 CN 102483758 A 5/2012
 CN 103843010 A 6/2014
 CN 104598439 A * 5/2015
 CN 104620240 A 5/2015
 KR 10-2008-0040064 A 5/2008
 KR 10-2014-0038707 A 3/2014
 KR 10-2015-0104646 A 9/2015
 WO 2009/148422 A1 12/2009
 WO 2015/163140 A1 10/2015

OTHER PUBLICATIONS

Pooshfam, Hamidreza, et al., "A Web-Based Framework for Resource Sharing and Collaborative Medical Image Annotation", BWCCA, Dec. 14, 2009, pp. 514-519, XP058286263, Kuala Lumpur, Malaysia.
 Jelena Tesic IBM T.J. Watson Research Center. Metadata Practices for Consumer Photos. KP011137101. John R. Smith, IBM. Standards. Jul.- Sep. 2005.
 European Examination Report dated Sep. 2, 2019, issued in European Application No. 16 864 556.2.
 U.S. Office Action dated Jun. 28, 2019, issued in U.S. Appl. No. 15/774,093.
 U.S. Office Action dated Jul. 15, 2019, issued in U.S. Appl. No. 16/426,650.
 U.S. Notice of Allowance dated Sep. 20, 2019, issued in U.S. Appl. No. 16/426,650.
 U.S. Office Action dated Feb. 20, 2020, issued in U.S. Appl. No. 15/774,093.
 Chinese Examination report dated Mar. 26, 2021, issued in Chinese Application No. 201680066127.0.
 Jiewen Wu et al., "A Study of Ontology-based Query Expansion", Cheriton School of Computer Science, University of Waterloo, XP 055055169, Mar. 4, 2013.
 J. Bhogal et al., "A Review of Ontology Based Query Expansion", ScienceDirect, XP 007913613, Oct. 23, 2006.
 European Notice of Result of consultation dated Jan. 13, 2021, issued in European Application No. 16864556.2-1213.
 U.S. Office Action dated Jul. 20, 2020, issued in U.S. Appl. No. 15/774,093.
 Alaa M. Riad et al., "A Literature Review of Image Retrieval Based on Semantic Concert", International Journal of Computer Applications, vol. 40, No. 11, Dec. 29, 2012, XP 055690063.
 European Examination Report dated Aug. 14, 2020, issued in European Application No. 16864556.2-1213.

* cited by examiner

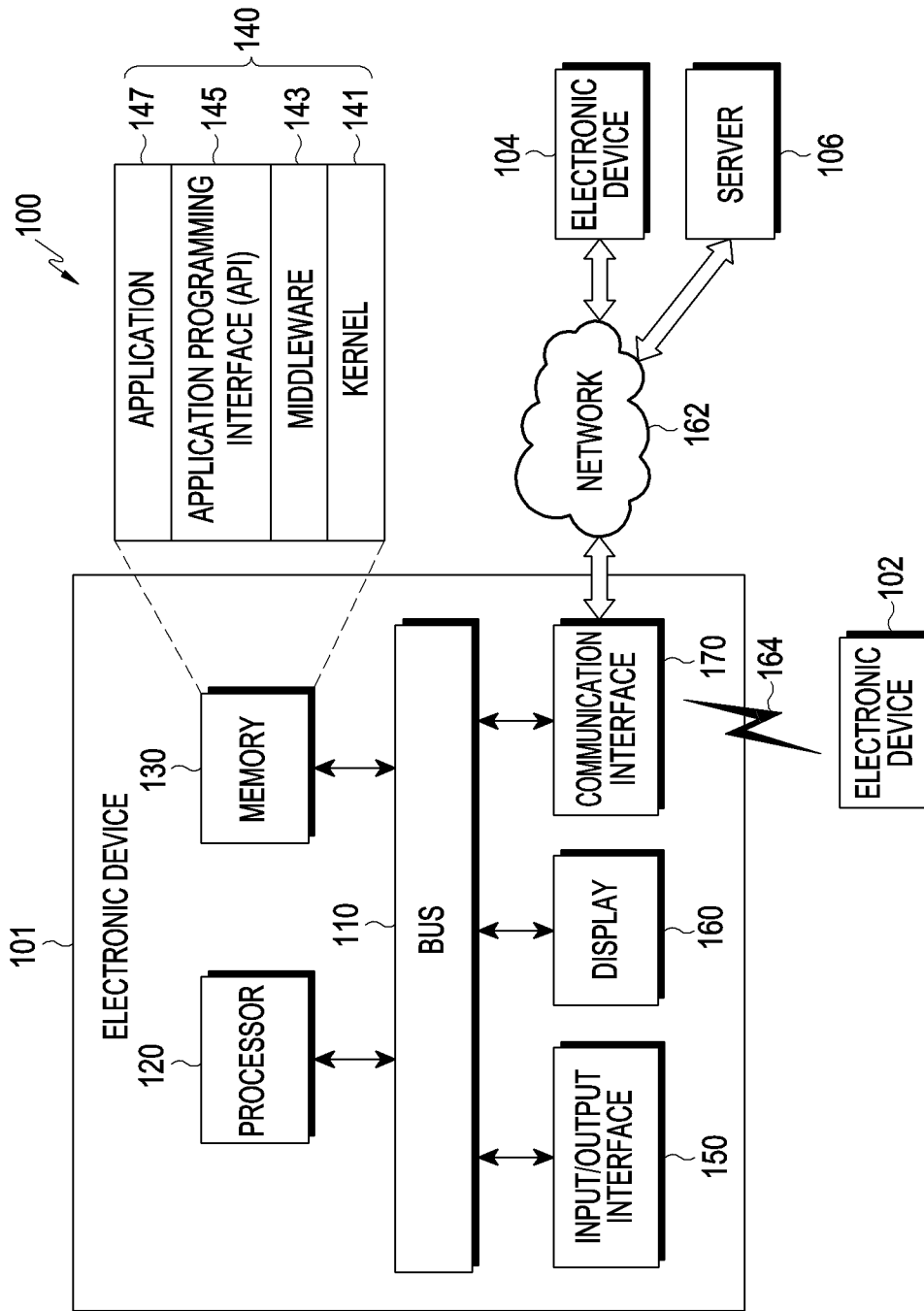

FIG. 1

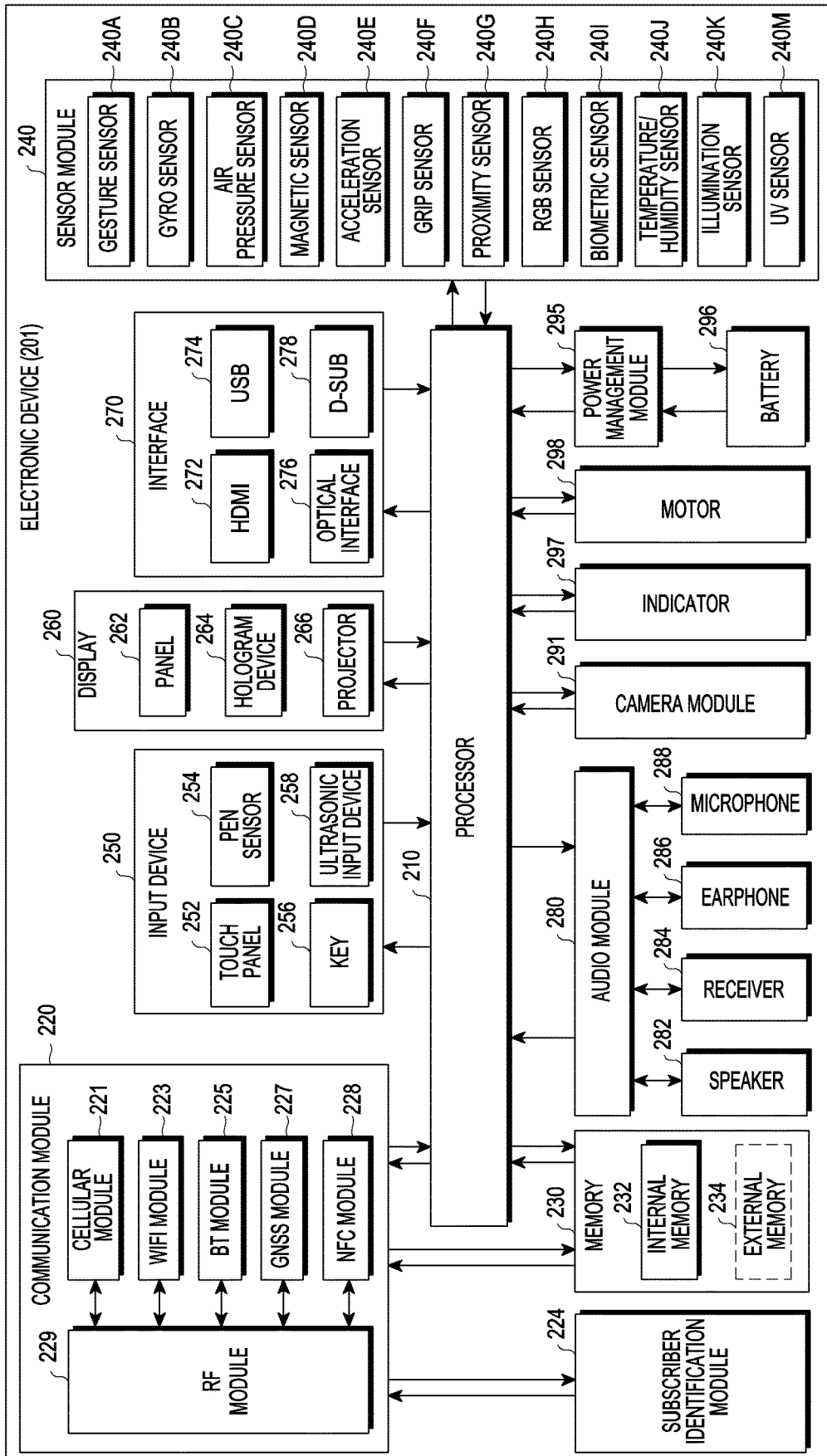

FIG.2

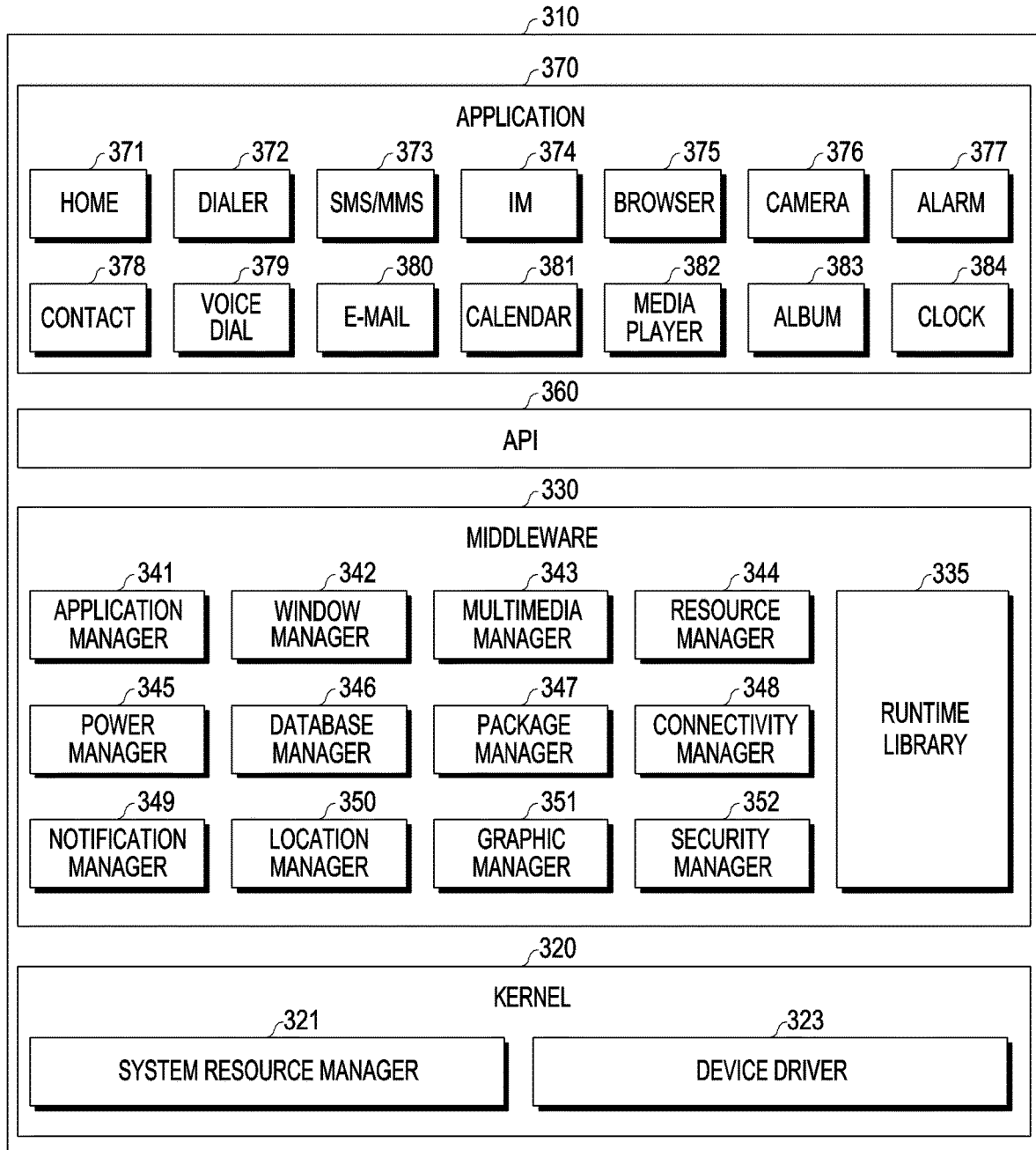

FIG.3

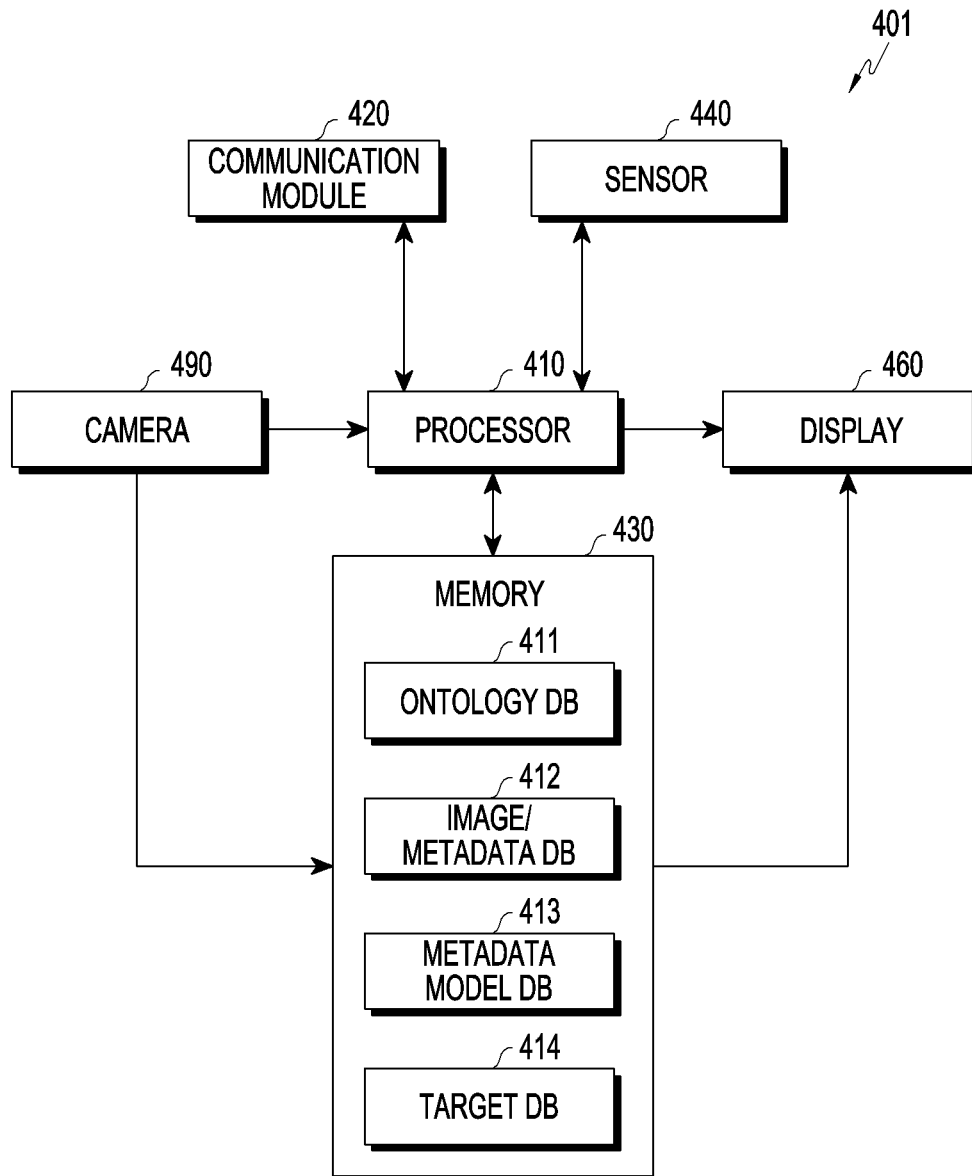

FIG.4

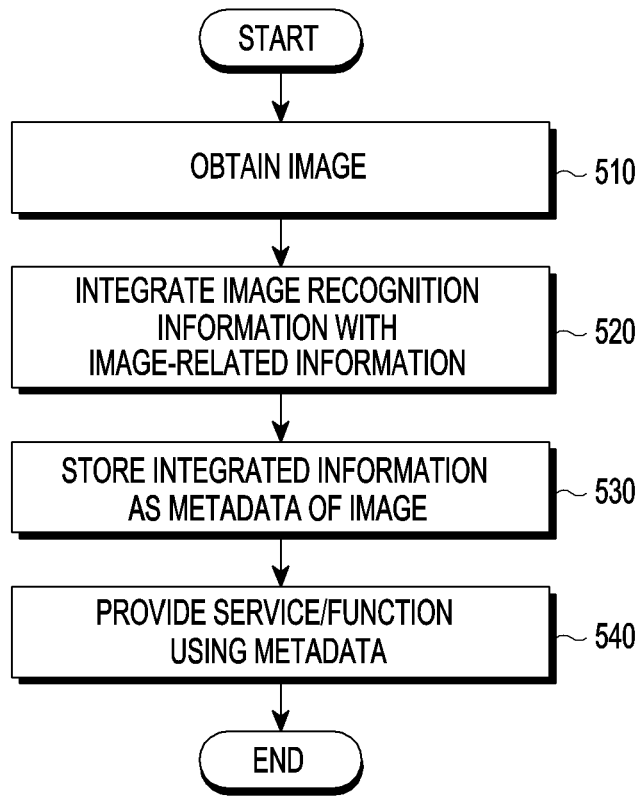

FIG.5

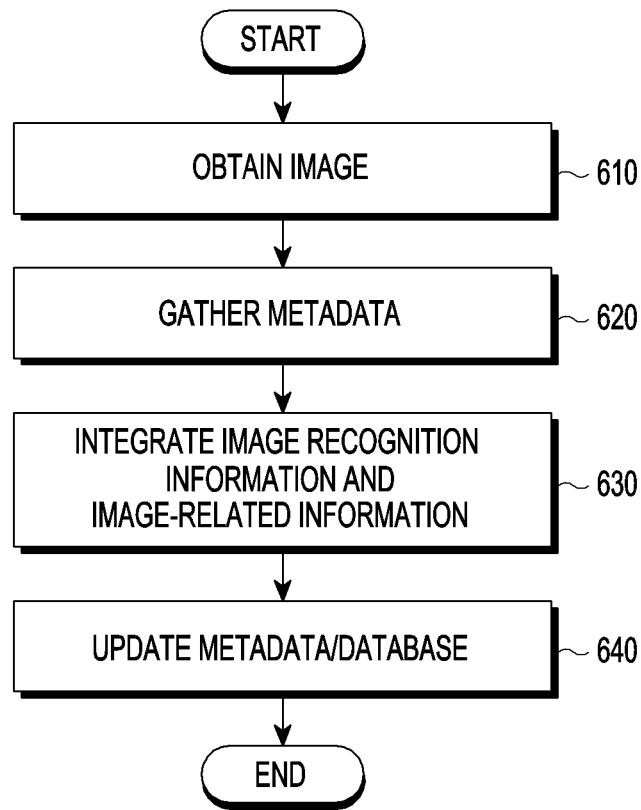

FIG.6

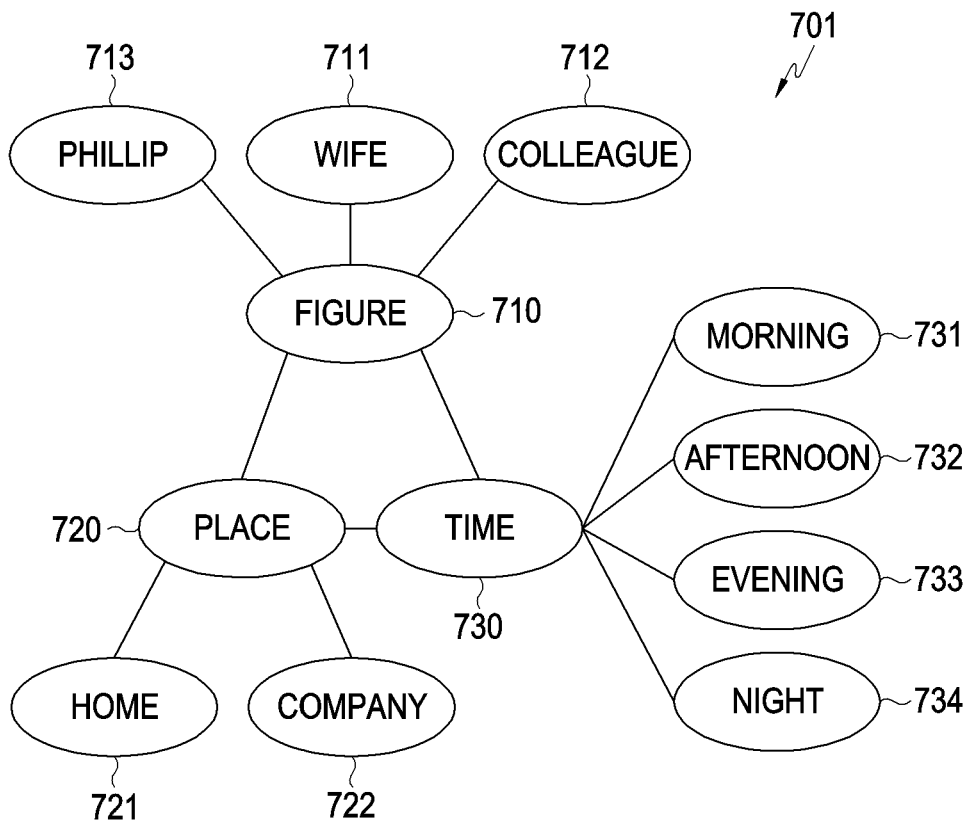

FIG.7A

702 ↙

	711 WIFE	712 COLLEAGUE	721 HOME	722 COMPANY	..
711 ~	WIFE	X	O	O	..
712 ~	COLLEAGUE	O	X	O	21
721 ~	HOME	O	O	X	O
722 ~	COMPANY	O	21	O	X

MORNING
(731)

FIG.7B

703 ↙

	711 WIFE	712 COLLEAGUE	721 HOME	722 COMPANY	..	
711 ~	WIFE	X	O	67	O	..
712 ~	COLLEAGUE	O	X	O	O	
721 ~	HOME	67	O	X	O	
722 ~	COMPANY	O	O	O	X	

EVENING
(733)

FIG.7C

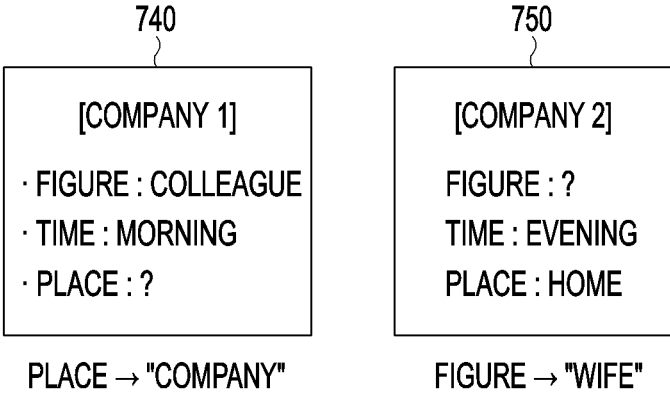

FIG.7D

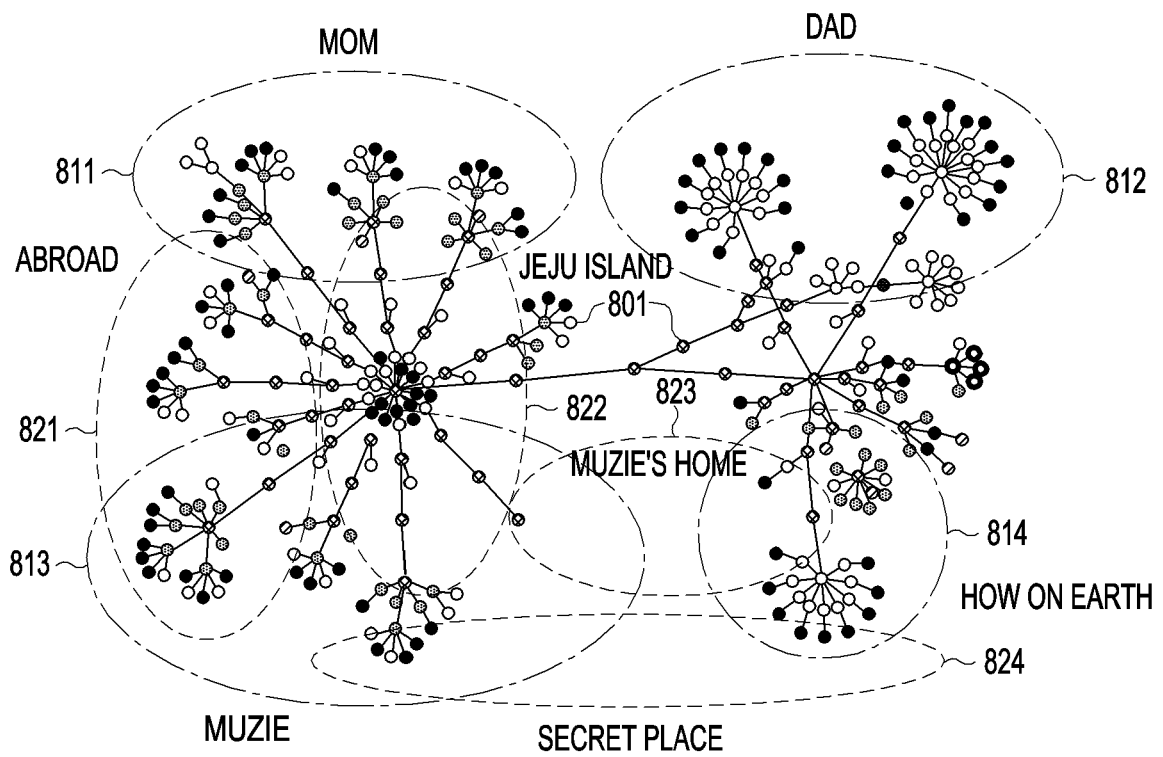

FIG.8

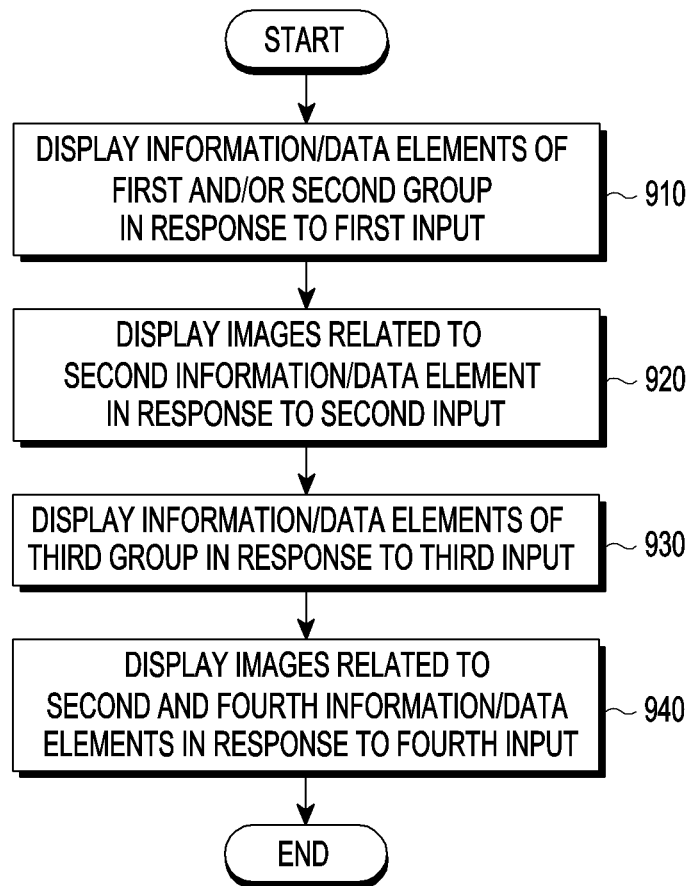

FIG.9

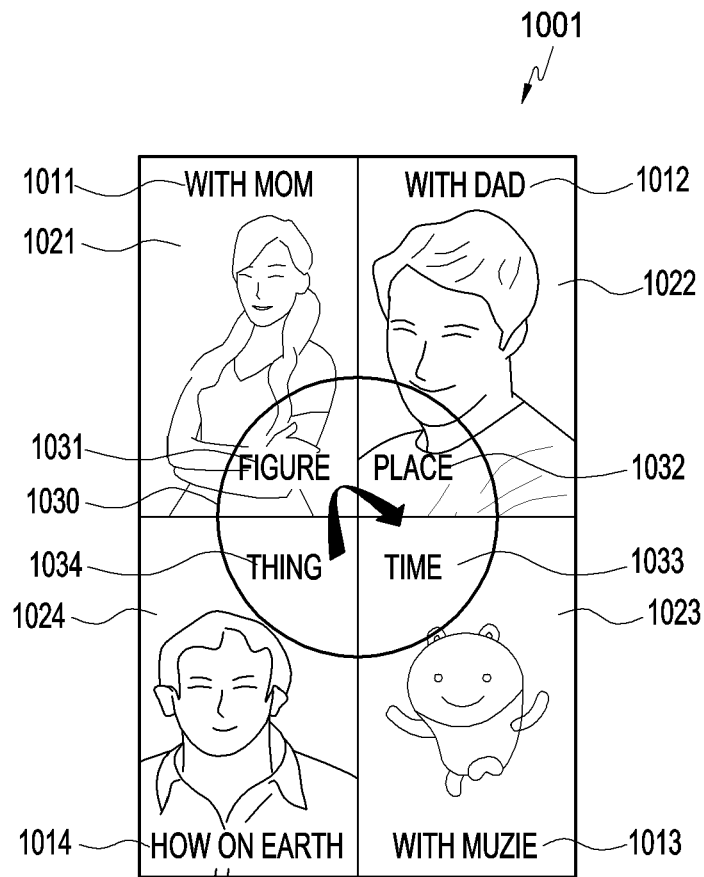

FIG. 10A

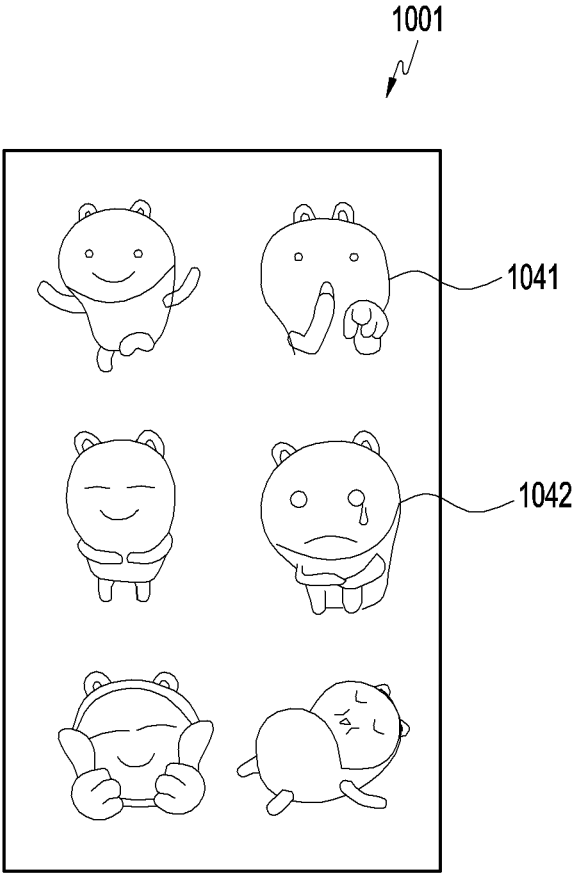

FIG. 10B

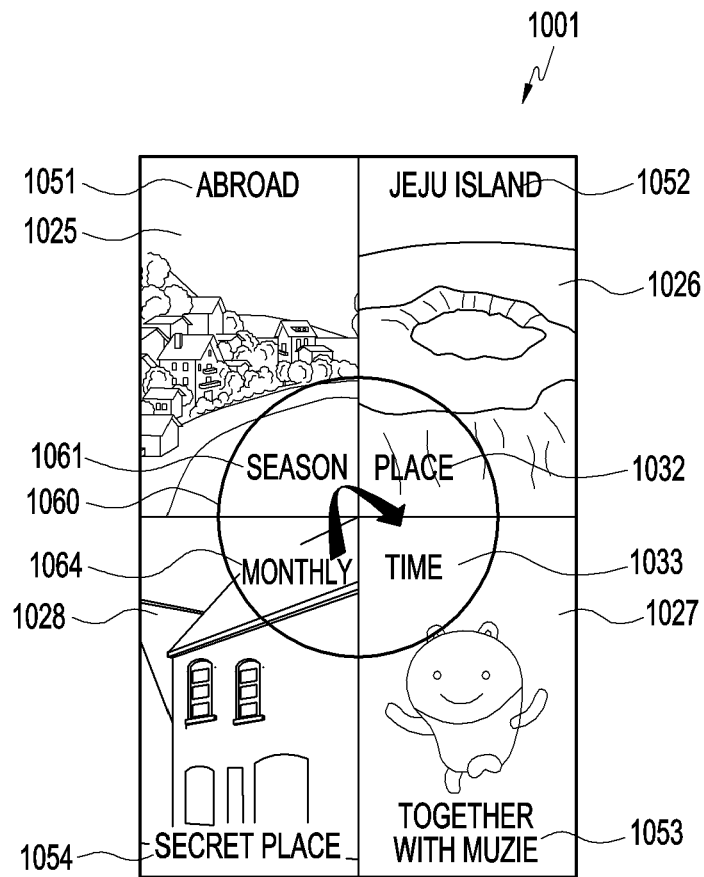

FIG. 10C

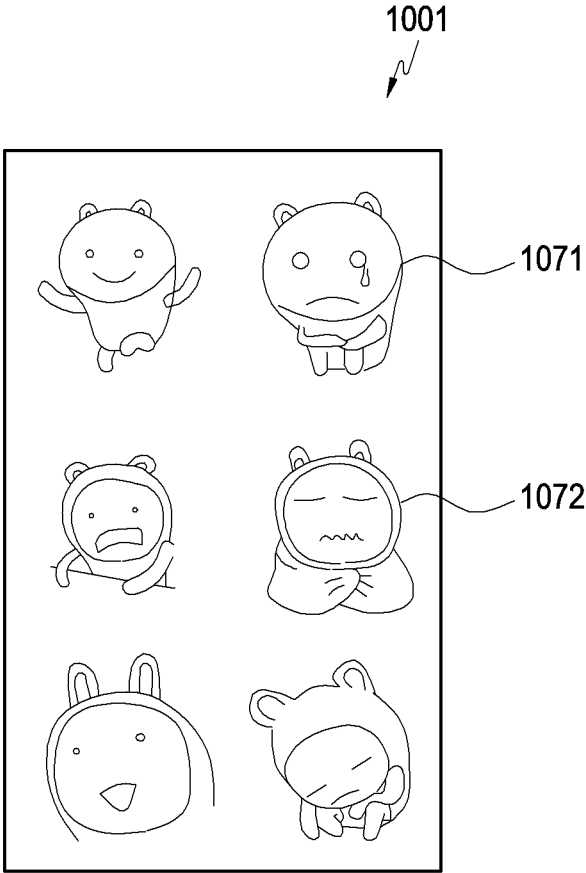

FIG.10D

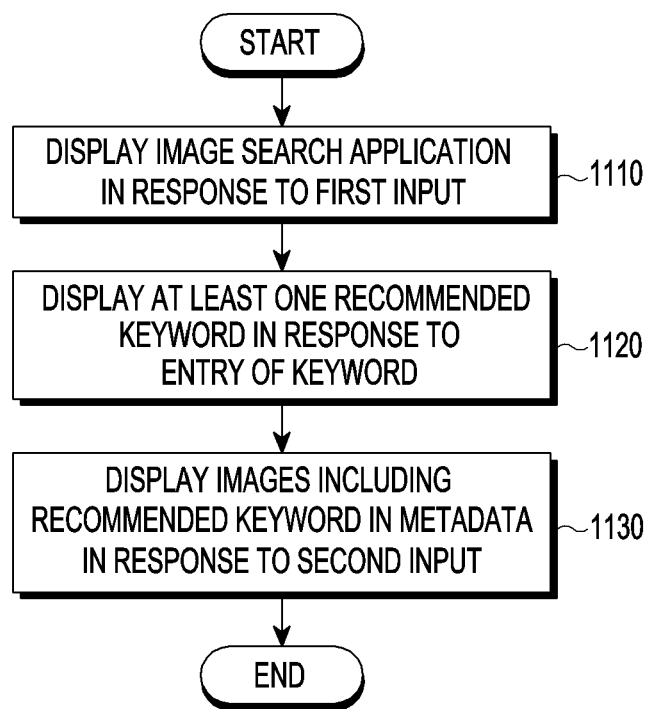

FIG. 11

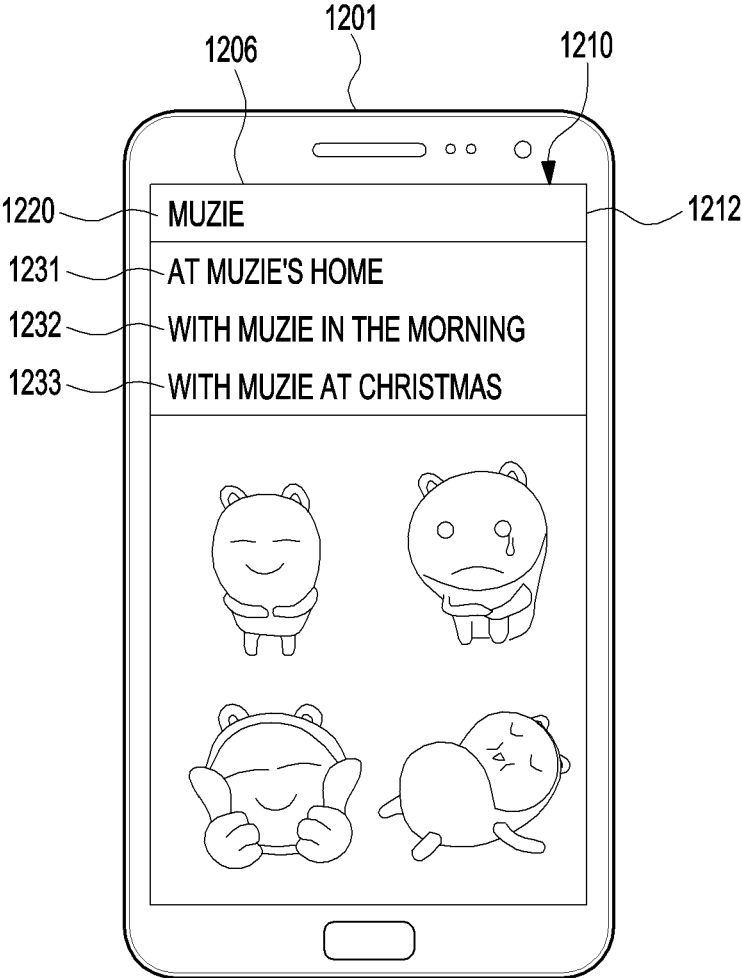

FIG.12A

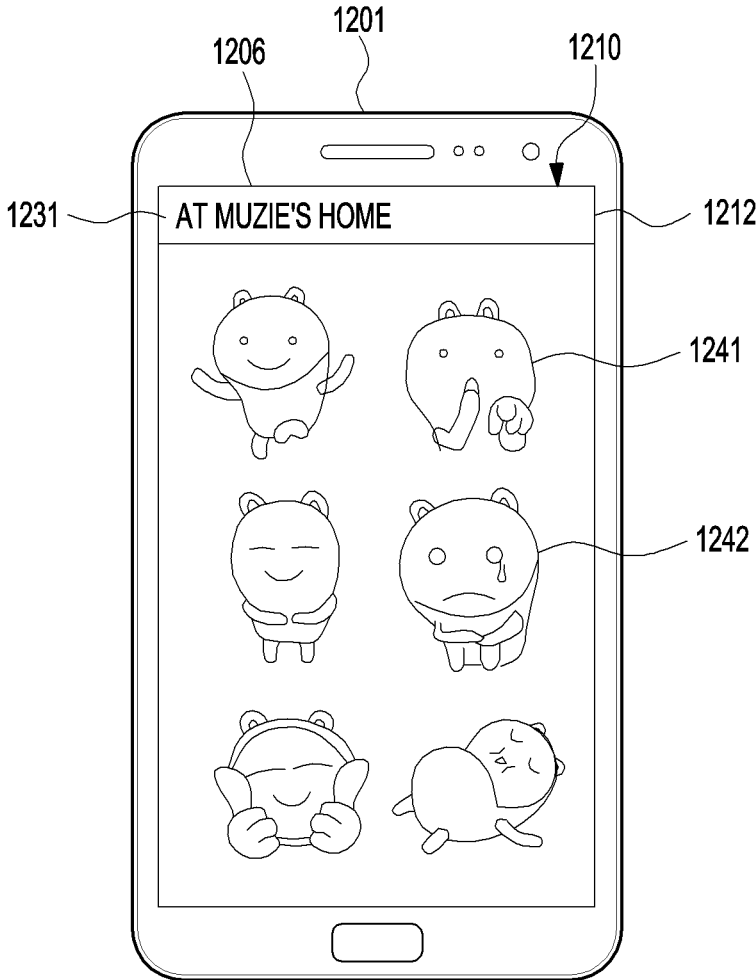

FIG. 12B

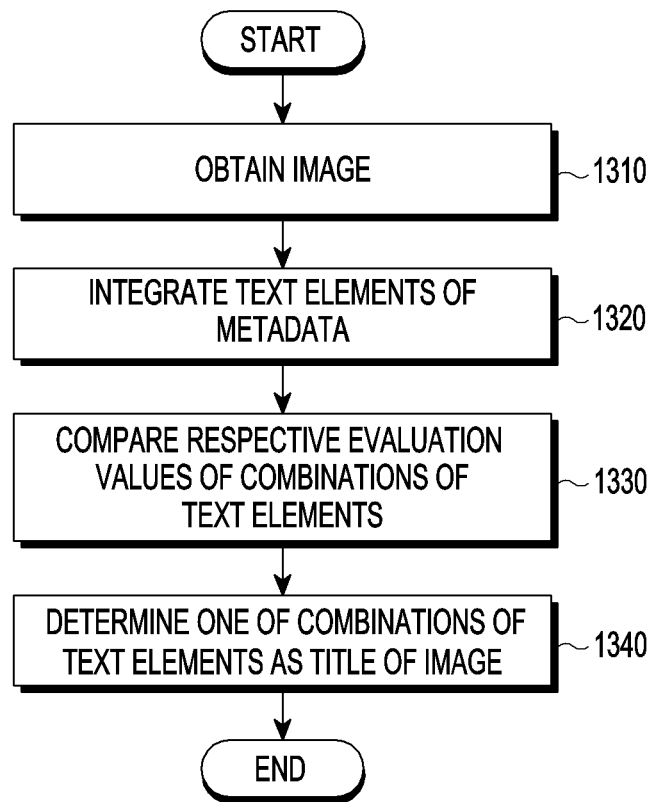

FIG. 13

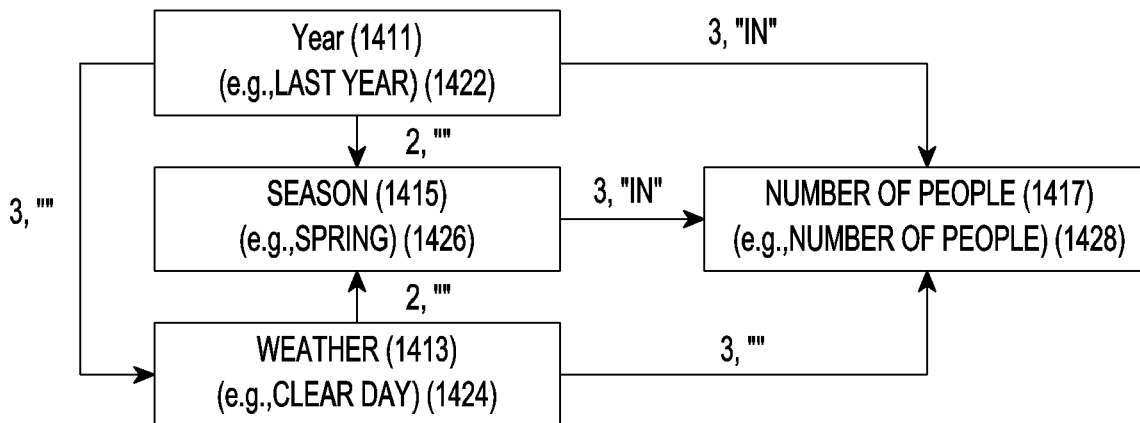

FIG.14A

	Title	Score
1438	PHOTO TAKEN ALONE ON CLEAR DAY IN SPRING LAST YEAR	8
1436	PHOTO TAKEN ALONE ON CLEAR DAY LAST YEAR	6
1434	PHOTO TAKEN ALONE IN SPRING LAST YEAR	5
1432	PHOTO TAKEN ALONE LAST YEAR	3
Title Ranking & Selection		

FIG.14B

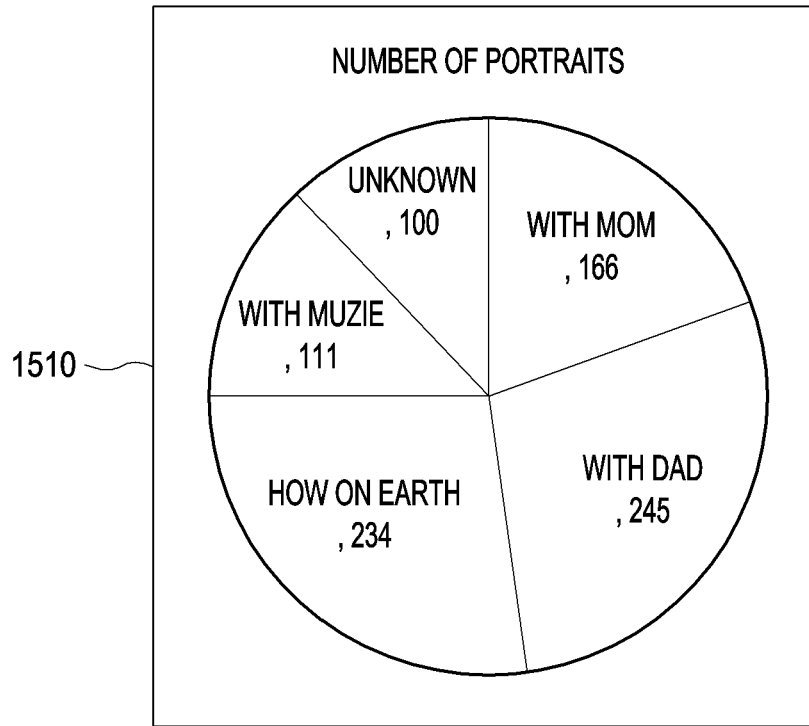

FIG.15A

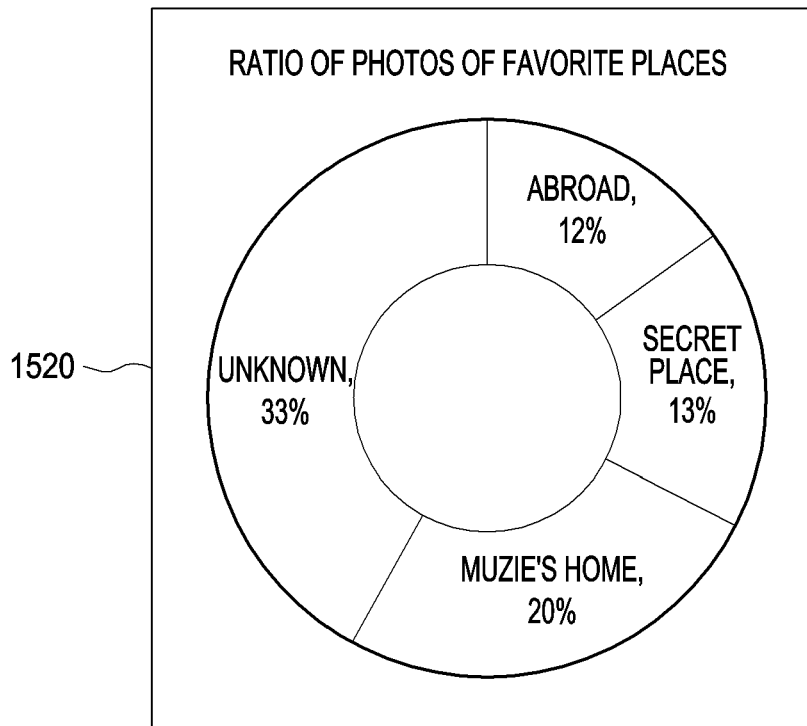

FIG.15B

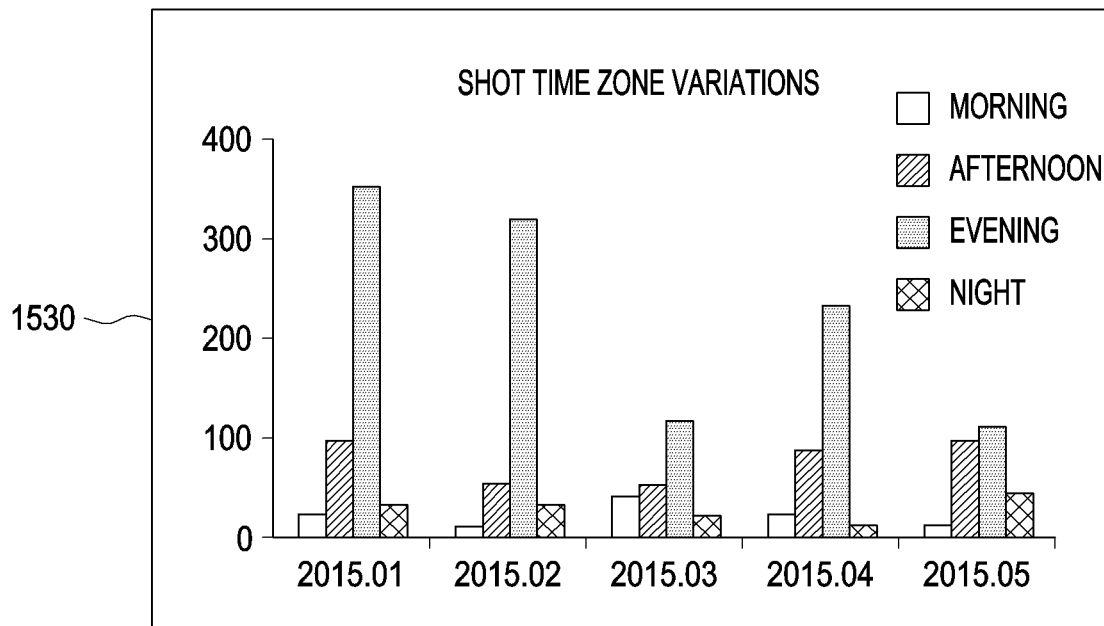

FIG.15C

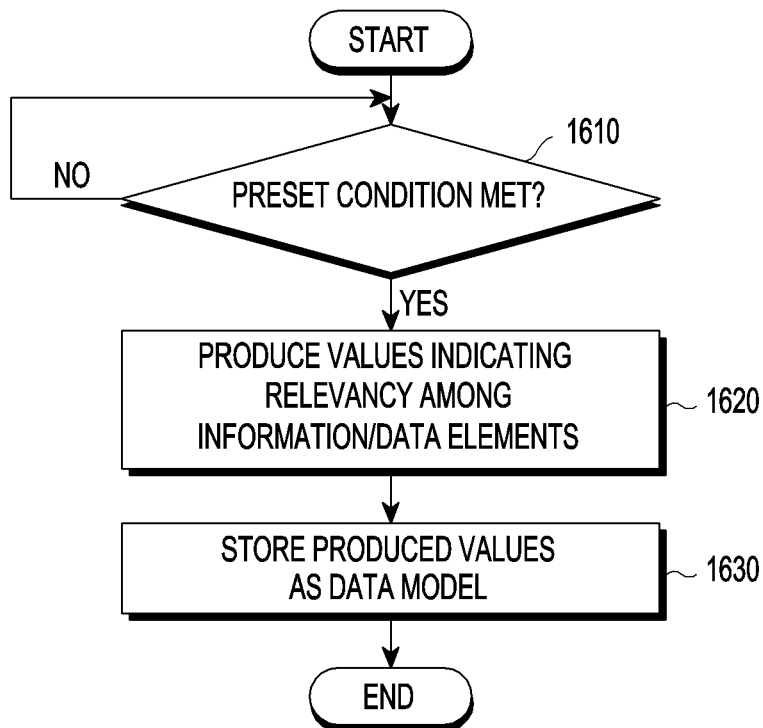

FIG.16

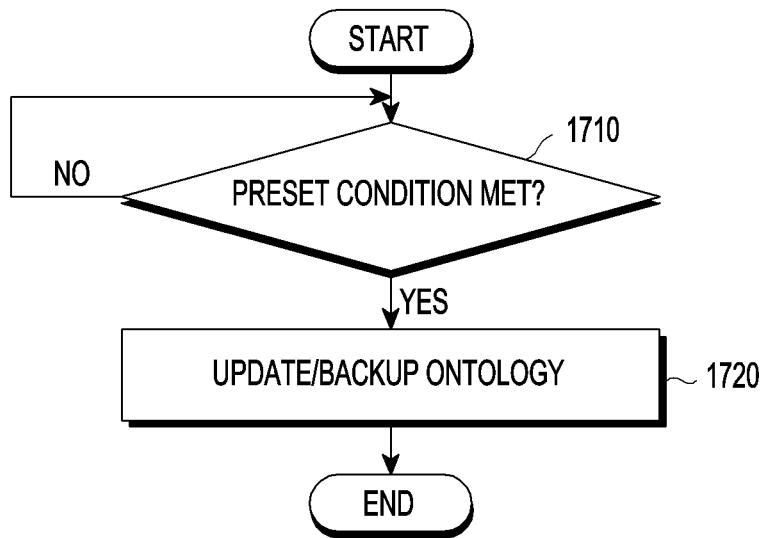

FIG.17

**DEVICE AND METHOD FOR PROCESSING
METADATA****CROSS-REFERENCE TO RELATED
APPLICATION(S)**

This application is a continuation of prior application Ser. No. 16/426,650 filed on May 30, 2019, which is a continuation of prior application Ser. No. 16/287,417, filed on Feb. 27, 2019, which has issued as U.S. Pat. No. 10,360,479 on Jul. 23, 2019, which was a continuation application of prior application Ser. No. 15/774,093, filed on May 7, 2018, which was a U.S. national stage application under 35 U.S.C. § 371 of an international application number PCT/KR2016/012871, filed on Nov. 9, 2016, which was based on and claimed priority under 35 U.S.C. § 119(a) of a Korean patent application number 10-2015-0158197, filed on Nov. 11, 2015, in the Korean Intellectual Property Office, the disclosure of each of which is incorporated by reference herein in its entirety.

TECHNICAL FIELD

The present invention relates to methods for processing metadata of images and electronic devices for the same.

BACKGROUND ART

Conventional electronic devices equipped with a camera may image-process images captured by the camera, compress the processed images and produce image files, and store the produced image files in a memory.

Conventional electronic devices may gather data about images and store the gathered data as metadata for the images.

**DETAILED DESCRIPTION OF THE
INVENTION****Technical Problem**

Conventional electronic devices merely provide metadata as assistant information about images, thus requiring a method for effective use of metadata.

Technical Solution

According to various embodiments, an operation method of an electronic device may comprise obtaining an image, integrating recognition information about the image with information related to the image, and storing the integrated information as metadata of the image or providing a service or a function using the integrated information.

According to various embodiments, an electronic device may comprise a memory and a processor configured to obtain an image, integrate recognition information about the image with information related to the image, and store the integrated information as metadata of the image in the memory or provide a service or a function using the integrated information.

Advantageous Effects

According to various embodiments, there may be provided various services using metadata by gathering various metadata of images and effectively combining/integrating

the gathered metadata based on ontology or storing the gathered metadata as ontology.

BRIEF DESCRIPTION OF DRAWINGS

FIG. 1 is a view illustrating an electronic device in a network environment according to various embodiments;

FIG. 2 is a block diagram illustrating an electronic device according to various embodiments;

FIG. 3 is a block diagram illustrating a program module according to various embodiments;

FIG. 4 is a view illustrating main components of an electronic device for performing a metadata processing method;

FIG. 5 is a flowchart illustrating a metadata processing method on an electronic device according to various embodiments;

FIG. 6 is a flowchart illustrating a metadata processing method on an electronic device according to various embodiments;

FIGS. 7A, 7B, 7C, and 7D are views illustrating a metadata modeling method on an electronic device according to various embodiments;

FIG. 8 is a view illustrating an image classifying method on an electronic device according to various embodiments;

FIG. 9 is a flowchart illustrating image search method on an electronic device according to various embodiments;

FIGS. 10A, 10B, 10C, and 10D are views illustrating an image search method on an electronic device according to various embodiments;

FIG. 11 is a flowchart illustrating image search method on an electronic device according to various embodiments;

FIGS. 12A and 12B are views illustrating an image search method on an electronic device according to various embodiments;

FIG. 13 is a flowchart illustrating an image title determining method on an electronic device according to various embodiments;

FIGS. 14A and 14B are views illustrating an image title determining method on an electronic device according to various embodiments;

FIGS. 15A, 15B, and 15C are views illustrating a statistical information providing method on an electronic device according to various embodiments;

FIG. 16 is a flowchart illustrating a metadata model producing method on an electronic device according to various embodiments; and

FIG. 17 is a flowchart illustrating an ontology update/backup method on an electronic device according to various embodiments.

MODE FOR CARRYING OUT THE INVENTION

Hereinafter, embodiments of the present disclosure are described with reference to the accompanying drawings. However, it should be appreciated that the present disclosure is not limited to the embodiments, and all changes and/or equivalents or replacements thereto also belong to the scope of the present disclosure. The same or similar reference denotations may be used to refer to the same or similar elements throughout the specification and the drawings.

As used herein, the terms “have,” “may have,” “include,” or “may include” a feature (e.g., a number, function, operation, or a component such as a part) indicate the existence of the feature and do not exclude the existence of other features.

As used herein, the terms “A or B,” “at least one of A and/or B,” or “one or more of A and/or B” may include all possible combinations of A and B. For example, “A or B,” “at least one of A and B,” “at least one of A or B” may indicate all of (1) including at least one A, (2) including at least one B, or (3) including at least one A and at least one B.

As used herein, the terms “first” and “second” may modify various components regardless of importance and/or order and are used to distinguish a component from another without limiting the components. For example, a first user device and a second user device may indicate different user devices from each other regardless of the order or importance of the devices. For example, a first component may be denoted a second component, and vice versa without departing from the scope of the present disclosure.

It will be understood that when an element (e.g., a first element) is referred to as being (operatively or communicatively) “coupled with/to,” or “connected with/to” another element (e.g., a second element), it can be coupled or connected with/to the other element directly or via a third element. In contrast, it will be understood that when an element (e.g., a first element) is referred to as being “directly coupled with/to” or “directly connected with/to” another element (e.g., a second element), no other element (e.g., a third element) intervenes between the element and the other element.

As used herein, the terms “configured (or set) to” may be interchangeably used with the terms “suitable for,” “having the capacity to,” “designed to,” “adapted to,” “made to,” or “capable of” depending on circumstances. The term “configured (or set) to” does not essentially mean “specifically designed in hardware to.” Rather, the term “configured to” may mean that a device can perform an operation together with another device or parts. For example, the term “processor configured (or set) to perform A, B, and C” may mean a generic-purpose processor (e.g., a CPU or application processor) that may perform the operations by executing one or more software programs stored in a memory device or a dedicated processor (e.g., an embedded processor) for performing the operations.

The terms as used herein are provided merely to describe some embodiments thereof, but not to limit the scope of other embodiments of the present disclosure. It is to be understood that the singular forms “a,” “an,” and “the” include plural references unless the context clearly dictates otherwise. The terms including technical and scientific terms used herein have the same meaning as commonly understood by one of ordinary skill in the art to which the embodiments of the present disclosure belong. It will be further understood that terms, such as those defined in commonly used dictionaries, should be interpreted as having a meaning that is consistent with their meaning in the context of the relevant art and will not be interpreted in an idealized or overly formal sense unless expressly so defined herein. In some cases, the terms defined herein may be interpreted to exclude embodiments of the present disclosure.

For example, examples of the electronic device according to various embodiments may include at least one of a smartphone, a tablet personal computer (PC), a mobile phone, a video phone, an e-book reader, a desktop PC, a laptop computer, a netbook computer, a workstation, a server, a personal digital assistant (PDA), a portable multimedia player (PMP), a MP3 player, a mobile medical device, a camera, or a wearable device. According to various embodiments, the wearable device may include at least one

of an accessory-type device (e.g., a watch, a ring, a bracelet, an anklet, a necklace, glasses, contact lenses, or a head-mounted device (HMD)), a fabric- or clothes-integrated device (e.g., electronic clothes), a body attaching-type device (e.g., a skin pad or tattoo), or a body implantable device (e.g., an implantable circuit).

According to some embodiments, the electronic device may be a home appliance. Examples of the home appliance may include at least one of a television, a digital video disk (DVD) player, an audio player, a refrigerator, an air conditioner, a cleaner, an oven, a microwave oven, a washer, a drier, an air cleaner, a set-top box, a home automation control panel, a security control panel, a TV box (e.g., Samsung HomeSync™, Apple TV™, or Google TV™), a gaming console (Xbox™, PlayStation™), an electronic dictionary, an electronic key, a camcorder, or an electronic picture frame.

According to other embodiments, examples of the electronic device may include at least one of various medical devices (e.g., diverse portable medical measuring devices (a blood sugar measuring device, a heartbeat measuring device, or a body temperature measuring device), a magnetic resource angiography (MRA) device, a magnetic resource imaging (MRI) device, a computed tomography (CT) device, an imaging device, or an ultrasonic device), a navigation device, a global navigation satellite system (GNSS) receiver, an event data recorder (EDR), a flight data recorder (FDR), an automotive infotainment device, an sailing electronic device (e.g., a sailing navigation device or a gyro compass), avionics, security devices, vehicular head units, industrial or home robots, automatic teller’s machines (ATMs), point of sales (POS) devices, or internet of things (IoT) devices (e.g., a bulb, various sensors, an electric or gas meter, a sprinkler, a fire alarm, a thermostat, a street light, a toaster, fitness equipment, a hot water tank, a heater, or a boiler).

According to some embodiments, examples of the electronic device may include at least one of part of a piece of furniture or building/structure, an electronic board, an electronic signature receiving device, a projector, or various measurement devices (e.g., devices for measuring water, electricity, gas, or electromagnetic waves). According to various embodiments, the electronic device may be one or a combination of the above-listed devices. According to some embodiments, the electronic device may be a flexible electronic device. The electronic device disclosed herein is not limited to the above-listed devices and may include new electronic devices depending on the development of technology.

Hereinafter, electronic devices are described with reference to the accompanying drawings, according to various embodiments. As used herein, the term “user” may denote a human or another device (e.g., an artificial intelligent electronic device) using the electronic device.

Referring to FIG. 1, according to various embodiments, an electronic device **100** is included in a network environment **101**. The electronic device **101** may include a bus **110**, a processor **120**, a memory **130**, an input/output interface **150**, a display **160**, and a communication module **170** (or communication interface). In some embodiments, the electronic device **101** may exclude at least one of the components or may add another component.

The bus **110** may include a circuit for connecting the components **120**, **130**, **150**, **160**, and **170** with one another and transferring communications (e.g., control messages and/or data) between the components.

The processor **120** may include one or more of a central processing unit (CPU), an application processor (AP), or a communication processor (CP). The processor **120** may perform control on at least one of the other components of the electronic device **101**, and/or perform an operation or data processing relating to communication. The processor **120** may be denoted a controller, or the processor **120** may include a controller as part thereof or may configure the controller.

The memory **130** may include a volatile and/or non-volatile memory. For example, the memory **130** may store commands or data related to at least one other component of the electronic device **101**. According to an embodiment, the memory **130** may store software and/or a program **140**. The program **140** may include, e.g., a kernel **141**, middleware **143**, an application programming interface (API) **145**, and/or an application program (or “application”) **147**. At least a portion of the kernel **141**, middleware **143**, or API **145** may be denoted an operating system (OS).

For example, the kernel **141** may control or manage system resources (e.g., the bus **110**, processor **120**, or a memory **130**) used to perform operations or functions implemented in other programs (e.g., the middleware **143**, API **145**, or application program **147**). The kernel **141** may provide an interface that allows the middleware **143**, the API **145**, or the application **147** to access the individual components of the electronic device **101** to control or manage the system resources.

The middleware **143** may function as a relay to allow the API **145** or the application **147** to communicate data with the kernel **141**, for example.

Further, the middleware **143** may process one or more task requests received from the application program **147** in order of priority. For example, the middleware **143** may assign at least one of application programs **147** with priority of using system resources (e.g., the bus **110**, processor **120**, or memory **130**) of at least one electronic device **101**. For example, the middleware **143** may perform scheduling or load balancing on the one or more task requests by processing the one or more task requests according to the priority assigned to the at least one application program **147**.

The API **145** is an interface allowing the application **147** to control functions provided from the kernel **141** or the middleware **143**. For example, the API **133** may include at least one interface or function (e.g., a command) for filing control, window control, image processing or text control.

The input/output interface **150** may serve as an interface that may, e.g., transfer commands or data input from a user or other external devices to other component(s) of the electronic device **101**. Further, the input/output interface **150** may output commands or data received from other component(s) of the electronic device **101** to the user or the other external device.

The display **160** may include, e.g., a liquid crystal display (LCD), a light emitting diode (LED) display, an organic light emitting diode (OLED) display, or a microelectromechanical systems (MEMS) display, or an electronic paper display. The display **160** may display, e.g., various contents (e.g., text, images, videos, icons, or symbols) to the user. The display **160** may include a touchscreen and may receive, e.g., a touch, gesture, proximity or hovering input using an electronic pen or a body portion of the user.

For example, the communication module **170** may set up communication between the electronic device **101** and an external device (e.g., a first electronic device **102**, a second electronic device **104**, or a server **106**). For example, the communication module **170** may be connected with the

network **162** through wireless or wired communication to communicate with the external electronic device (e.g., the second external electronic device **104** or server **106**). The communication module **170** may include a communication processor (CP), and the communication processor may configure one of a plurality of modules in the communication module **170**. According to an embodiment, the communication processor may be included in the processor **120**.

The wireless communication may use at least one of, e.g., long term evolution (LTE), long term evolution-advanced (LTE-A), code division multiple access (CDMA), wideband code division multiple access (WCDMA), universal mobile telecommunication system (UMTS), wireless broadband (WiBro), or global system for mobile communication (GSM), as a cellular communication protocol. Further, the wireless communication may include, e.g., short-range communication **164**. The short-range communication **164** may include at least one of, e.g., wireless fidelity (Wi-Fi), Bluetooth, near-field communication (NFC), or global navigation satellite system (GNSS). The GNSS may include at least one of, e.g., global positioning system (GPS), global navigation satellite system (GLONASS), Beidou navigation satellite system (hereinafter, “Beidou”) or Galileo, or the European global satellite-based navigation system. Hereinafter, the terms “GPS” and the “GNSS” may be interchangeably used herein. The wired connection may include at least one of, e.g., universal serial bus (USB), high definition multimedia interface (HDMI), recommended standard (RS)-232, or plain old telephone service (POTS). The network **162** may include at least one of communication networks, e.g., a computer network (e.g., local area network (LAN) or wide area network (WAN)), Internet, or a telephone network.

The first and second external electronic devices **102** and **104** each may be a device of the same or a different type from the electronic device **101**. According to an embodiment, the server **106** may include a group of one or more servers. According to various embodiments, all or some of operations executed on the electronic device **101** may be executed on another or multiple other electronic devices (e.g., the electronic devices **102** and **104** or server **106**). According to an embodiment, when the electronic device **101** should perform some function or service automatically or at a request, the electronic device **101**, instead of executing the function or service on its own or additionally, may request another device (e.g., electronic devices **102** and **104** or server **106**) to perform at least some functions associated therewith. The other electronic device (e.g., electronic devices **102** and **104** or server **106**) may execute the requested functions or additional functions and transfer a result of the execution to the electronic device **101**. The electronic device **101** may provide a requested function or service by processing the received result as it is or additionally. To that end, a cloud computing, distributed computing, or client-server computing technology may be used, for example.

FIG. 2 is a block diagram illustrating an electronic device **201** according to various embodiments. The electronic device **201** may include the whole or part of the configuration of, e.g., the electronic device **101** shown in FIG. 1. The electronic device **201** may include one or more processors (e.g., application processors (APs)) **210**, a communication module **220**, a memory **230**, a sensor module **240**, an input device **250**, and a display **260**, and the electronic device **201** may further include at least one of a subscription identification module **224**, an interface **270**, an audio module **280**,

a camera module **291**, a power management module **295**, a battery **296**, an indicator **297**, and a motor **298**.

The processor **210** may control multiple hardware and software components connected to the processor **210** by running, e.g., an operating system or application programs, and the processor **210** may process and compute various data. The processor **210** may be implemented in, e.g., a system on chip (SoC). According to an embodiment, the processor **210** may further include a graphic processing unit (GPU) and/or an image signal processor. The processor **210** may include at least some (e.g., the cellular module **221**) of the components shown in FIG. 2. The processor **210** may load a command or data received from at least one of other components (e.g., a non-volatile memory) on a volatile memory, process the command or data, and store various data in the non-volatile memory.

The communication module **220** may have the same or similar configuration to the communication module **170** of FIG. 1. The communication module **220** may include at least one of, e.g., a cellular module **221**, a wireless fidelity (Wi-Fi) module **223**, a Bluetooth (BT) module **225**, a GNSS module **227**, an NFC module **228**, and a RF module **229**.

The cellular module **221** may provide voice call, video call, text, or Internet services through, e.g., a communication network. The cellular module **221** may perform identification or authentication on the electronic device **201** in the communication network using a subscriber identification module **224** (e.g., the SIM card). According to an embodiment, the cellular module **221** may perform at least some of the functions providable by the processor **210**. According to an embodiment, the cellular module **221** may include a communication processor (CP).

The Wi-Fi module **223**, the Bluetooth module **225**, the GNSS module **227**, or the NFC module **228** may include a process for, e.g., processing data communicated through the module. According to some embodiments, at least some (e.g., two or more) of the cellular module **221**, the Wi-Fi module **223**, the Bluetooth module **225**, the GNSS module **227**, or the NFC module **228** may be included in a single integrated circuit (IC) or an IC package.

The RF module **229** may communicate data, e.g., communication signals (e.g., RF signals). The RF module **229** may include, e.g., a transceiver, a power amp module (PAM), a frequency filter, a low noise amplifier (LNA), or an antenna. According to another embodiment, at least one of the cellular module **221**, the Wi-Fi module **223**, the Bluetooth module **225**, the GNSS module **227**, or the NFC module **228** may communicate RF signals through a separate RF module.

The subscription identification module **224** may include, e.g., a card including a subscriber identification module and/or an embedded SIM, and may contain unique identification information (e.g., an integrated circuit card identifier (ICCID) or subscriber information (e.g., an international mobile subscriber identity (IMSI)).

The memory **230** (e.g., the memory **130**) may include, e.g., an internal memory **232** or an external memory **234**. The internal memory **232** may include at least one of, e.g., a volatile memory (e.g., a dynamic RAM (DRAM), a static RAM (SRAM), a synchronous dynamic RAM (SDRAM), etc.) or a non-volatile memory (e.g., a one time programmable ROM (OTPROM), a programmable ROM (PROM), an erasable and programmable ROM (EPROM), an electrically erasable and programmable ROM (EEPROM), a mask ROM, a flash ROM, a flash memory (e.g., a NAND flash, or a NOR flash), a hard drive, or solid state drive (SSD).

The external memory **234** may include a flash drive, e.g., a compact flash (CF) memory, a secure digital (SD) memory, a micro-SD memory, a mini-SD memory, an extreme digital (xD) memory, a multi-media card (MMC), or a Memory Stick™. The external memory **234** may be functionally and/or physically connected with the electronic device **201** via various interfaces.

For example, the sensor module **240** may measure a physical quantity or detect a motion state of the electronic device **201**, and the sensor module **240** may convert the measured or detected information into an electrical signal. The sensor module **240** may include at least one of, e.g., a gesture sensor **240A**, a gyro sensor **240B**, an atmospheric pressure sensor **240C**, a magnetic sensor **240D**, an acceleration sensor **240E**, a grip sensor **240F**, a proximity sensor **240G**, a color sensor **240H** (e.g., a red-green-blue (RGB) sensor), a bio sensor **240I**, a temperature/humidity sensor **240J**, an illumination sensor **240K**, or an Ultra Violet (UV) sensor **240M**. Additionally or alternatively, the sensing module **240** may include, e.g., an e-nose sensor, an electro-myography (EMG) sensor, an electroencephalogram (EEG) sensor, an electrocardiogram (ECG) sensor, an infrared (IR) sensor, an iris sensor, or a finger print sensor. The sensor module **240** may further include a control circuit for controlling at least one or more of the sensors included in the sensing module. According to some embodiments, the electronic device **201** may further include a processor configured to control the sensor module **240** as part of the processor **210** or separately from the processor **210**, and the electronic device **2701** may control the sensor module **240** while the processor **210** is in a sleep mode.

The input unit **250** may include, e.g., a touch panel **252**, and the input device **250** may further include at least one of a (digital) pen sensor **254**, a key **256**, or an ultrasonic input device **258**. The touch panel **252** may use at least one of capacitive, resistive, infrared, or ultrasonic methods. The touch panel **252** may further include a control circuit. The touch panel **252** may further include a tactile layer and may provide a user with a tactile reaction.

The (digital) pen sensor **254** may include, e.g., a part of a touch panel or a separate sheet for recognition. The key **256** may include e.g., a physical button, optical key or key pad. The ultrasonic input device **258** may sense an ultrasonic wave generated from an input tool through a microphone (e.g., the microphone **288**) to identify data corresponding to the sensed ultrasonic wave.

The display **260** (e.g., the display **160**) may include a panel **262**, and the display **260** may further include a hologram device **264** and/or a projector **266**. The panel **262** may have the same or similar configuration to the display **160** of FIG. 1. The panel **262** may be implemented to be flexible, transparent, or wearable. The panel **262** may also be incorporated with the touch panel **252** in a module. The hologram device **264** may make three dimensional (3D) images (holograms) in the air by using light interference. The projector **266** may display an image by projecting light onto a screen. The screen may be, for example, located inside or outside of the electronic device **201**. In accordance with an embodiment, the display **260** may further include a control circuit to control the panel **262**, the hologram device **264**, or the projector **266**.

The interface **270** may include at least one of, e.g., a high definition multimedia interface (HDMI) **272**, a USB **274**, an optical interface **276**, or a D-subminiature (D-sub) **278**. The interface **270** may be included in e.g., the communication module **170** shown in FIG. 1. Additionally or alternatively, the interface **270** may include a mobile high-definition link

(MHL) interface, a secure digital (SD) card/multimedia card (MMC) interface, or infrared data association (IrDA) standard interface.

The audio module **280** may convert a sound into an electric signal or vice versa, for example. At least a part of the audio module **280** may be included in e.g., the input/output interface **150** as shown in FIG. 1. The audio module **280** may process sound information input or output through e.g., a speaker **282**, a receiver **284**, an earphone **286**, or a microphone **288**.

For example, the camera module **291** may be a device for capturing still images and videos, and may include, according to an embodiment, one or more image sensors (e.g., front and back sensors), a lens, an image signal processor (ISP), or a flash such as an LED or xenon lamp.

The power manager module **295** may manage power of the electronic device **201**, for example. According to an embodiment, the power manager module **295** may include a power management Integrated circuit (PMIC), a charger IC, or a battery or fuel gauge. The PMIC may have a wired and/or wireless recharging scheme. The wireless charging scheme may include e.g., a magnetic resonance scheme, a magnetic induction scheme, or an electromagnetic wave-based scheme, and an additional circuit, such as a coil loop, a resonance circuit, a rectifier, or the like may be added for wireless charging. The battery gauge may measure an amount of remaining power of the battery **296**, a voltage, a current, or a temperature while the battery **296** is being charged. The battery **296** may include, e.g., a rechargeable battery or a solar battery.

The indicator **297** may indicate a particular state of the electronic device **201** or a part (e.g., the processor **210**) of the electronic device, including e.g., a booting state, a message state, or recharging state. The motor **298** may convert an electric signal to a mechanical vibration and may generate a vibrational or haptic effect. Although not shown, a processing unit for supporting mobile TV, such as a GPU may be included in the electronic device **201**. The processing unit for supporting mobile TV may process media data conforming to a standard for digital multimedia broadcasting (DMB), digital video broadcasting (DVB), or media-Flo™.

Each of the aforementioned components of the electronic device may include one or more parts, and a name of the part may vary with a type of the electronic device. The electronic device in accordance with various embodiments of the present disclosure may include at least one of the aforementioned components, omit some of them, or include other additional component(s). Some of the components may be combined into an entity, but the entity may perform the same functions as the components may do.

FIG. 3 is a block diagram illustrating a program module according to various embodiments. According to an embodiment, the program module **310** (e.g., the program **140**) may include an operating system (OS) controlling resources related to the electronic device (e.g., the electronic device **101**) and/or various applications (e.g., the application processor **147**) driven on the operating system. The operating system may include, e.g., Android, iOS, Windows, Symbian, Tizen, or Bada.

The program **310** may include, e.g., a kernel **320**, middleware **330**, an application programming interface (API) **360**, and/or an application **370**. At least a part of the program module **310** may be preloaded on the electronic device or may be downloaded from an external electronic device (e.g., at least one of the electronic devices **102** and **104** or server **106**).

The kernel **320** (e.g., the kernel **141**) may include, e.g., a system resource manager **321** and/or a device driver **323**. The system resource manager **321** may perform control, allocation, or recovery of system resources. According to an embodiment, the system resource manager **321** may include a process managing unit, a memory managing unit, or a file system managing unit. The device driver **323** may include, e.g., a display driver, a camera driver, a Bluetooth driver, a shared memory driver, a USB driver, a keypad driver, a Wi-Fi driver, an audio driver, or an inter-process communication (IPC) driver.

The middleware **330** may provide various functions to the application **370** through the API **360** so that the application **370** may efficiently use limited system resources in the electronic device or provide functions jointly required by applications **370** according to an embodiment, the middleware **330** (e.g., the middleware **143**) may include at least one of a runtime library **335**, an application manager **341**, a window manager **342**, a multimedia manager **343**, a resource manager **344**, a power manager **345**, a database manager **346**, a package manager **347**, a connectivity manager **348**, a notification manager **349**, a location manager **350**, a graphic manager **351**, or a security manager **352**.

The runtime library **335** may include a library module used by a compiler in order to add a new function through a programming language while, e.g., the application **370** is being executed. The runtime library **335** may perform input/output management, memory management, or operation on arithmetic functions.

The application manager **341** may manage the life cycle of at least one application of, e.g., the applications **370**. The window manager **342** may manage graphical user interface (GUI) resources used on the screen. The multimedia manager **343** may grasp formats necessary to play various media files and use a codec appropriate for a format to perform encoding or decoding on media files. The resource manager **344** may manage resources, such as source code of at least one of the applications **370**, memory or storage space.

The power manager **345** may operate together with, e.g., a basic input/output system (BIOS) to manage battery or power and provide power information necessary for operating the electronic device. The database manager **346** may generate, search, or vary a database to be used in at least one of the applications **370**. The package manager **347** may manage installation or update of an application that is distributed in the form of a package file.

The connectivity manager **348** may manage wireless connectivity, such as, e.g., Wi-Fi or Bluetooth. The notification manager **349** may display or notify an event, such as a coming message, appointment, or proximity notification, of the user without interfering with the user. The location manager **350** may manage locational information on the electronic device. The graphic manager **351** may manage graphic effects to be offered to the user and their related user interface. The security manager **352** may provide various security functions necessary for system security or user authentication. According to an embodiment, when the electronic device (e.g., the electronic device **101**) has telephony capability, the middleware **330** may further include a telephony manager for managing voice call or video call functions of the electronic device.

The middleware **330** may include a middleware module forming a combination of various functions of the above-described components. The middleware **330** may provide a specified module per type of the operating system in order

to provide a differentiated function. Further, the middleware **330** may dynamically omit some existing components or add new components.

The API **360** (e.g., the API **145**) may be a set of, e.g., API programming functions and may have different configurations depending on operating systems. For example, in the case of Android or iOS, one API set may be provided per platform, and in the case of Tizen, two or more API sets may be offered per platform.

The application **370** (e.g., the application processor **147**) may include one or more applications that may provide functions such as, e.g., a home **371**, a dialer **372**, a short message service (SMS)/multimedia messaging service (MMS) **373**, an instant message (IM) **374**, a browser **375**, a camera **376**, an alarm **377**, a contact **378**, a voice dial **379**, an email **380**, a calendar **381**, a media player **382**, an album **383**, or a clock **384**, a health-care (e.g., measuring the degree of workout or blood sugar), or provision of environmental information (e.g., provision of air pressure, moisture, or temperature information).

According to an embodiment, the application **370** may include an application (hereinafter, "information exchanging application" for convenience) supporting information exchange between the electronic device (e.g., the electronic device **101**) and an external electronic device (e.g., the electronic devices **102** and **104**). Examples of the information exchange application may include, but is not limited to, a notification relay application for transferring specific information to the external electronic device, or a device management application for managing the external electronic device.

For example, the notification relay application may include a function for relaying notification information generated from other applications of the electronic device (e.g., the SMS/MMS application, email application, health-care application, or environmental information application) to the external electronic device (e.g., the electronic devices **102** and **104**). Further, the notification relay application may receive notification information from, e.g., the external electronic device and may provide the received notification information to the user.

The device management application may perform at least some functions of the external electronic device (e.g., the electronic device **102** or **104**) communicating with the electronic device (for example, turning on/off the external electronic device (or some components of the external electronic device) or control of brightness (or resolution) of the display), and the device management application may manage (e.g., install, delete, or update) an application operating in the external electronic device or a service (e.g., call service or message service) provided from the external electronic device.

According to an embodiment, the application **370** may include an application (e.g., a health-care application of a mobile medical device) designated according to an attribute of the external electronic device (e.g., the electronic devices **102** and **104**). According to an embodiment, the application **370** may include an application received from the external electronic device (e.g., the server **106** or electronic devices **102** and **104**). According to an embodiment, the application **370** may include a preloaded application or a third-party application downloadable from a server. The names of the components of the program module **310** according to the shown embodiment may be varied depending on the type of operating system.

According to various embodiments, at least a part of the program module **310** may be implemented in software,

firmware, hardware, or in a combination of two or more thereof. At least a part of the programming module **310** may be implemented (e.g., executed) by e.g., a processor (e.g., the processor **210**). At least a part of the program module **310** may include e.g., a module, program, routine, set of commands, process, or the like for performing one or more functions.

FIG. **4** is a view illustrating main components of an electronic device for performing a metadata processing method.

The electronic device **401** (e.g., the electronic device **101** or **201**) may include, e.g., a camera **490** (e.g., the camera module **291**), a memory **430** (e.g., the memory **130** or **230**), a display **460** (e.g., the display **160** or **260**), a sensor **440** (e.g., at least one of the sensor module **240**, the touch panel **252**, the GNSS module **227**, and the microphone **288**), a communication module **420** (e.g., the communication module **170** or **220**), and a processor **410** (e.g., the processor **120** or **210**).

The camera **490** may capture object(s) in front or behind the electronic device **401** and output the captured image(s) of the object(s). For example, the camera **490** may include a first camera module (or back face/rear camera module) for capturing an object behind the electronic device **401** and a second camera module (or front face/front camera module) for capturing an object in front of the electronic device **401**. For example, each camera module may capture still images or video under the control of the processor **410** and output the captured still images or video to the processor **410** or memory **430**. The processor **410** may store the captured still images or video in the memory **430** or display them on the display **460**. For example, each camera module may produce a preview image (or live preview image) for the target in front or behind and output the produced preview image to the processor **410** or the display **460**. The processor **410** may display the preview image on the display **460**. For example, the processor **410** may display images retained in the memory **430** on the display **460**.

The display **460** may display images, signals, data, or information input from the camera **490**, the memory **430**, or the processor **410** on the screen.

The memory **430** may include an ontology database **411**, an image/metadata database **412**, a metadata model database **413**, and a target database **414**. The image/metadata database **412**, the ontology database **411**, and the metadata model database **413** may be parts of one database. The ontology database **411** and the metadata model database **413** may be parts of one database. At least part of the ontology database **411** and the metadata model database **413** may be integrated with the image/metadata database **412**. The databases **411** to **414** may be parts of at least one database. The ontology and metadata model may be regarded as metadata or part of metadata.

The ontology database **411** may include a plurality of ontologies, and each ontology may include a plurality of information/data elements and data defining the relation among the plurality of information/data elements.

For example, the ontology, as a data model specifying a particular domain, may be composed of a set of concepts (or information/data elements) belonging to a particular domain and formal words specifying the relation among the concepts. An ontology, a set of words written in a formal language may be used for deduction and inference. For example, the ontology may include Class that indicates the name or category of a thing or concept, Instance that indicates a specific item or incident, a substantial form of representation of a thing or concept, Property, a connection

between a class or instance and a particular value to represent a particular nature or propensity of the class or instance, and Relation that indicates relations (e.g., at least one of an inclusive relation, identical relation, and causal relation) present among classes or instances. At this time, Property may be included in Relation.

The ontology database 411 may have various data structures. For example, the plurality of information/data elements may be represented in the form of a data/object tree according to the relation among the plurality of information/data elements or as multiple records specifying the plurality of information/data elements and the relation among the plurality of information/data elements.

As an example of the ontology database 411, the ontology database 411 may store a plurality of information in the form of multiple records as set forth below in Table 1.

TABLE 1

ID	Type	Content	Property	Relation
L1	M1	N1	O1	P1
L2	M2	N2	O2	P2
L3	M3	N3	O3	P3
L4	M4	N4	O4	P4
...
Ln	Mn	Nn	On	Pn

ID Li ($1 \leq i \leq n$, where n is an integer not less than 1) denotes unique identification information about the information/data element, type Mi and Content Ni respectively denote identification information about the class/instance and the name of the information/data element, property Oi denotes a particular value, e.g., accuracy, and relation Pi denotes the relation with other information/data elements. Each field in the ontology database 411 may have one or more values; each value may be, e.g., a constant, coordinate, vector, matrix, or text.

For example, the ontology database 411 may include the ontology “[dad]-{married couple}-[mom].” Here, “[dad]” and “[mom]” correspond to information/data elements (or entities), and “[married couple]” corresponds to a relation. Further, the category/topic/class “figure (or people)” in the ontology database 411 to which “[dad]” and “[mom]” may also correspond to an information/data element (or entity).

The image/metadata database 412 may include a plurality of images and a plurality of metadata each corresponding to a respective one of the plurality of images. The plurality of metadata may be stored in the form of a database with a plurality of data records. Each of the plurality of images may be a still image file or video file.

For example, the still image file may have at least one extension of BMP(*.BMP, *.RLE), JPEG(*.JPG), CompuServe GIF(*.GIF), PNG(*.PNG), Photoshop(*.PSD, *.PDD), TIFF(*.TIF), Acrobat PDF(*.PDF), RAW(*.RAW), Illustrator(*.AI), Illustrator, Photoshop EPS(*.EPS), Amiga IFF(*.IFF), FlaschPix(*.FPX), Filmstrip(*.FRM), PCX(*.PCX), PICT Fe(*.PCT, *.PIC), Pixar(*.PXR), Scitex(*.SCT), or Targa(*.TGA, *.VDA, *.ICB, *.VST).

For example, the video file may include image information and audio information. For example, the video file may have at least one extension of mpeg, mpg, mp4, avi, mov, or mkv. For example, the audio information may be recorded together with an image when the image is captured through the camera 490.

Each of the plurality of metadata may include recognition information about the corresponding image and information

related to the image obtained through the camera 490, the memory 430, the sensor 440, and/or the communication module 420.

The metadata model database 413 may include information (or values) or data model indicating the relevancy among common information/data elements in the plurality of metadata.

The target database 414 may be provided to recognize a preset object (or the whole or part of a human or the whole or part of a thing (including a natural thing, such as a cloud, sky, and sea)). Target data for recognizing the object may include, e.g., an image of the object or information about feature points (or also denoted feature images or feature patterns) of the object image. Such feature points may be edges, corners, image patterns, or contours.

In one embodiment, the target data for recognizing the object may include a recognition reference that may be defined by shape characteristics such as the shape/motion/size/color/brightness of a thing/human and as a category such as figures/flowers/sky/pets/buildings.

The sensor 440 may be used to detect user input information or context information indicating the context/condition where an image is captured. For example, the sensor 440 may detect at least one of the target captured, time captured, location/place captured, and ambient sounds when/while being captured.

The communication module 420 may be used to search for images on an external database/system/network or to receive recognition about images from an external device (e.g., the first external electronic device 102, second external electronic device 104, or server 106).

The processor 410 may include at least one of a central processing unit (CPU), an application processor (AP), or a communication processor (CP), an ISP, or a GPU.

The processor 410 may receive images captured by the camera 490 from the camera 490 or read images stored in the memory 430.

In one embodiment, the processor 410 may recognize information included in the image based on the target database 414.

In one embodiment, the processor 410 may transmit the image and/or information related to the image to an external device (e.g., the first external electronic device 102, the second external electronic device 104, or the server 106) and receive recognition information about the image from the external device.

In one embodiment, the processor 410 may detect, through the sensor 440, context information (e.g., at least one of the time captured, location/place captured, or ambient sounds when/while being captured) indicating the context/condition where the image is captured.

In one embodiment, the processor 410 may detect user input information (e.g., at least one of the title, tag, and memo of the image) related to the image through the sensor 440 or the display 460.

In one embodiment, the processor 410 may detect setting information about the camera 490 when/while the image is captured through the camera 490 or the memory 430. For example, the setting information may include at least one of capture start/end/whole time information, capture mode information (e.g., at least one of a nighttime mode, a figure mode, an indoor mode, a facial recognition mode, or a panoramic mode), information about a section/area/portion-of-interest information, or capture rate (or frame rate) information.

The processor 410 may integrate the recognition information with the image-related information based on the

ontology database **411** and/or metadata model database **413**. The processor **410** may store the integrated information, as metadata of the image, in the image/metadata database **412**, the ontology database **411**, and/or metadata model database **413** or may provide services or functions using the metadata.

In one embodiment, the services or functions may include at least one of database update functions/services, image discovery/search services, keyword recommending services, image title providing services, and statistical information providing services.

In one embodiment, the target database **414** may store data or information about the composition/arrangement of targets. Such composition information may include information about a plurality of objects, and information about each object may include information about the type (or name) of the object and information about the location, size, direction, and scene category of the object.

The object type information may be, e.g., people, plants, animals, buildings, roads, geography, and nature (e.g., at least one sea, rivers, lakes, or sky).

The object location information may be the location of a representative point (e.g., central point) of the object and locations of corner points defining the object. Such a location may be represented by, e.g., coordinates or a ratio (e.g., a point positioned away from the leftmost end of the image by 1/3 of the overall width of the image or a point positioned away from the top of the image by 1/3 of the overall height of the image).

The object size information may be represented by, e.g., a constant, coordinates (coordinates of the corner points), a ratio (e.g., a point position away from the leftmost end of the image by 1/3 of the whole width of the image or a point positioned away from the top of the image by 1/3 of the whole height of the image).

The object direction information represents the pose, orientation, or direction of the object, e.g., information about the direction where the object faces (e.g., forward, left, right, up, or down). The object direction information may be represented by the two-dimensional or three-dimensional Cartesian coordinate system or five directions including forward, left, right, up, and down or nine directions including forward, left, right, up, down, left-and-up, left-and-down, right-and-up, and right-and-down.

The scene category may represent the category/type (e.g., at least one of a downtown intersection, in front of a crosswalk, a beach, a riverside, or a street/sidewalk in front of or alongside a building) of the overall scene of the image entered.

The target database **414** may have various data structures and may store a plurality of information in the form of multiple records as set forth in, e.g., Table 2 below.

TABLE 2

Record number	Object type	Object location/size	Object direction	Scene Category
A1	B1	C1	D1	E1
A2	B2	C2	D2	E1
A3	B3	C3	D3	E2
A4	B4	C4	D4	E1/E2
...
An	Bn	Cn	Dn	Em

Each record Ai (1 ≤ i ≤ n, where n is an integer not less than 1) includes fields, such as object type Bi, object location/size Ci, object direction Di, and overall scene category Ei. A plurality of object information may correspond to each scene

category Ei. Each object information piece may include object type Bi, a plurality of object locations/sizes Ci, and a plurality of object directions Di. m is an integer not less than 1 and smaller than n. Each object information piece may correspond to a plurality of scene categories. The object location/size Ci may be represented as the coordinates of diagonal corner points defining the object or as the central position or size of the object. Each field may have one or more values; each value may be, e.g., a constant, coordinate, vector, matrix, or text.

The processor **410** may recognize an object from an image captured by the camera **490** or an image stored in the memory **430**. The processor **410** may recognize what the object in the image is through a recognition algorithm as per the type of the object. The processor **410** may also recognize what direction the object faces in what position (i.e., the position and pose of the object).

The processor **410** may estimate the pose by recognizing an object registered in the target database **414** from an input image through an algorithm, such as scale invariant feature transform (SIFT) or speeded up robust features (SURF) and applying a template-based matching method to the recognized object. SIFT is disclosed in "Lowe, David G. (1999). "Object recognition from local scale-invariant features." Proceedings of the International Conference on Computer Vision. 2. pp. 11501157. doi,10.1109/ICCV.1999.790410," and SURF is disclosed in "Bay, H., Tuytelaars, T., Gool, L. V., "SURF, Speeded Up Robust Features," Proceedings of the ninth European Conference on Computer Vision, May 2006." The pose estimation using template-based matching is disclosed in "Daniel Wagner, Gerhard Reitmayr, Alessandro Mulloni, Tom Drummond, Dieter Schmalstieg, "Real Time Detection and Tracking for Augmented Reality on Mobile Phones," Visualization and Computer Graphics, August 2009." The processor **410** may recognize the object registered in the target database **414** from the input image and estimate the pose of the object based on 2D or 3D object information stored in the target database **414**.

The processor **410** may recognize an image area matching the object registered in the target database **414** from the input image. Depending on the type of target recognized, the processor **410** may recognize the object without referring to the target database **414**. For example, the processor **410** may detect edge feature points and corner feature points from the input image and recognize a planar object, such as a rectangle, circle, or polygon, defined by the edge feature points and corner feature points.

The processor **410** may search for scene category information matching the composition/arrangement of objects recognized from the target database **414**. The processor **410** may detect corresponding scene categories based on the types, locations, and/or directions of the objects.

The processor **410** may recognize the target captured, location/place captured, or other context information based on at least one of information about the recognized objects (e.g., the types, locations, and/or directions of the recognized objects), scene category information about the recognized objects, and location information (e.g., location information through the GNSS module **227** or GPS module) about the electronic device **401**.

In one embodiment, the processor **410** may recognize the context information such as the target captured or location/place captured based on identification information and/or strength of a wireless signal (e.g., at least one of a Wi-Fi signal, a Bluetooth (BT) signal, or an NFC signal) received through the communication module **420**.

In one embodiment, the processor **410** may obtain information about an indoor capture location using an NFC module (e.g., the NFC module **228**) of the communication module **420**. For example, where NFC devices (e.g., NFC readers or sensors) are mounted at predetermined intervals in an indoor space or in predetermined positions inside an indoor space (e.g., at the doors or at the corners, lamp, center of the wall, floor or ceiling of each room), the processor **410** may grasp the location of the electronic device **401** by receiving NFC signals through the NFC module or location-related information from the NFC reader which receives NFC signals from the NFC module. For example, further enhanced accuracy may be achieved depending on the interval at which the NFC devices are deployed. The processor **410** may predict the coordinates of the electronic device **401** by grasping the travel distance and direction after detecting NFC signals.

In one embodiment, the processor **410** may determine location information about the electronic device **401** or an object captured by a marker technique. The marker technique is one to grasp the position of a particular marker included in an image by interpreting the marker and to grasp relative positions between the marker and electronic device **401**. The marker may be one or more of a barcode, a 2D code (QR code, PDF-417, data matrix, or ColorCode™) or a watermark. The processor **410** may grasp coordinates or direction information by decoding the marker. Since the marker deforms depending on the direction of capture by the camera **490**, the location information about the camera may be predicted through the pose or direction information or size information about the electronic device **401** or the location of the marker on the image.

In one embodiment, the target database **414** may include a radio signal fingerprint database that may include information about a distribution of wireless signals in an indoor space (e.g., identification information and strength of wireless signal per position). For example, the processor **410** may receive at least one wireless signal including identification information from an external device through the communication module **420**, and the processor **410** may compare and/or match the identification information and strength of the wireless signal with signal information (i.e., identification information and strength) in the wireless signal fingerprint database and may determine the location information about the electronic device **401** from location information in the wireless signal fingerprint database corresponding to the matching signal information.

According to various embodiments, an electronic device may comprise a memory and a processor configured to obtain an image, integrate recognition information about the image with information related to the image, and store the integrated information as metadata of the image in the memory or provide a service or a function using the integrated information.

According to various embodiments, integrating the recognition information with the image-related information may include integrating the recognition information with the image-related information based on a database defining a plurality of information/data elements and a relation among the plurality of information/data elements.

According to various embodiments, the image-related information may be detected by a sensor or communication module of the electronic device.

According to various embodiments, the method may be configured to perform at least one of receiving the image from external device, obtaining the image through capturing

by a camera of the electronic device, and reading the image stored in a memory of the electronic device.

According to various embodiments, the image may be a still image or a video.

According to various embodiments, the recognition information may include at least one of identification information about the user included in the image, identification information about a thing included in the image, composition information about objects included in the image, information about text included in the image, and color/chroma/lightness/brightness information about the image.

According to various embodiments, the image-related information may include at least one of context information indicating the capture context/condition for the image, user input information, and search information using an external database/system/network, and the context information may include at least one of time or location captured, ambient sounds when/while being captured, or camera setting information when/while being captured.

According to various embodiments, the method may be configured to recognize an object from the image and receive information about the recognized object from the user.

According to various embodiments, the method may be configured to recognize an object from the image and store information about the recognized object and information about a recognition accuracy/rate in the memory of the electronic device.

According to various embodiments, the method may be configured to recognize an object from the image and search the memory of the electronic device for information about the recognized object.

According to various embodiments, the method may be configured to transmit the image to an external device and receive recognition information about the image from the external device.

According to various embodiments, the method may be configured to access an external database/system/network, search the database/system/network for information about at least part of the image-related information or the image information, and store the searched-for information as part of the image-related information.

According to various embodiments, the image-related information may include text. The method may be configured to split the text into a plurality of text elements based on a database defining a plurality of information/data elements and a relation among the plurality of information/data elements and allow the plurality of text elements to correspond to categories/topics/classes in the database.

According to various embodiments, the method may be configured to produce information (or values) indicating the relevancy among the information/data elements in a plurality of metadata stored in the memory of the electronic device.

According to various embodiments, the method may be configured to determine whether a preset condition is met, and upon meeting the preset condition, produce values indicating the relevancy among the information/data elements in a plurality of metadata stored in the memory of the electronic device.

According to various embodiments, the method may be configured to determine whether a preset condition is met, upon meeting the preset condition, produce values indicating the relevancy among the information/data elements for a plurality of metadata stored in the memory of the electronic device and store the produced values as a data model.

According to various embodiments, the method may be configured to determine whether a preset condition is met, and upon meeting the preset condition, produce values indicating the relevancy among the information/data elements for a plurality of metadata stored in the memory of the electronic device. The preset condition may include at least one of arrival of a preset period, the usage of computing resources of the electronic device being not more than a preset threshold, the remaining battery life of the electronic device being not less than a preset threshold, the passage of a preset time from the last time that a metadata model was produced, the number of new images obtained being not less than a preset threshold, providing a service or function using metadata, receiving a user input, the electronic device booting up, a transition from a sleep mode of the electronic device to a normal mode, the display screen/power-on after entry into the sleep mode of the electronic device, executing an application including a graphical element (or item) (e.g., at least one of a button, icon, menu, or menu item) requiring a metadata model, displaying a screen including a graphical element requiring a metadata model, the user's approach to a graphical element requiring a metadata model, detecting a context associated with the electronic device that matches a preset context, or detecting at least one word matching at least one preset word.

According to various embodiments, the method may be configured to estimate information about the image based on values indicating the relevancy among the information/data elements for a plurality of metadata stored in the memory of the electronic device.

According to various embodiments, the method may be configured to update a database defining a plurality of information/data elements and a relation among the plurality of information/data elements using at least part of the recognition information or the image-related information.

According to various embodiments, the method may be configured to receive at least part of a database defining a plurality of information/data elements and a relation among the plurality of information/data elements from an external device.

According to various embodiments, the method may be configured to determine whether a preset condition is met, and upon meeting the preset condition, transmit at least part of a database defining a plurality of information/data elements and a relation among the plurality of information/data elements to the external device.

According to various embodiments, the method may be configured to classify images stored in the memory of the electronic device into a plurality of categories based on a database defining a plurality of information/data elements and a relation among the plurality of information/data elements and metadata of the images, and upon selecting one of the plurality of categories, display images belonging to the selected category.

According to various embodiments, the method may be configured to classify images stored in the memory of the electronic device into a plurality of categories based on a database defining a plurality of information/data elements and a relation among the plurality of information/data elements and metadata of the images, upon selecting one of the plurality of categories, display images belonging to the selected category, display sub-categories belonging to the selected category, and upon selecting one of the sub-categories, display images belonging to the selected sub-category.

According to various embodiments, the method may be configured to display information/data elements of a first group among a plurality of information/data elements in a

database defining the plurality of information/data elements and a relation among the plurality of information/data elements, in response to a first input and display images stored in a memory of the electronic device related to a first information/data element among the information/data elements of the first group, in response to a second input.

According to various embodiments, the method may be configured to display information/data elements of a second group among the plurality of information/data elements related to the first information/data element, in response to a third input and display the images stored in the memory of the electronic device related to the first information/data element and a second information/data element among the information/data elements of the second group, in response to a fourth input.

According to various embodiments, the method may be configured to display, together with the information/data elements of the first group, information/data elements of a third group among the plurality of information/data elements including a third information/data element related to the information/data elements of the first group, in response to the first input.

According to various embodiments, the method may be configured to display, together with the information/data elements of the second group, information/data elements of a fourth group among the plurality of information/data elements including a fourth information/data element related to the information/data elements of the second group, in response to the third input.

According to various embodiments, the information/data elements of the third or fourth group may be displayed on a graphical element that, as rotated, allows any one thereof to be selected.

According to various embodiments, the third input may be a swipe gesture of a preset pattern (e.g., L-shaped or C-shaped).

According to various embodiments, the method may be configured to integrate the text elements of the metadata based on a database defining a plurality of information/data elements and a relation among the plurality of information/data elements and store combinations of the text elements as a title of the image.

According to various embodiments, the method may be configured to integrate the text elements of the metadata based on a database defining a plurality of information/data elements and a relation among the plurality of information/data elements, compare the respective evaluation values for the combinations of the text elements, and determine one of the combinations of the text elements as the title of the image based on the comparison.

According to various embodiments, the method may be configured to receive a keyword and display images including the keyword in the metadata among images stored in the memory of the electronic device, in response to receiving the keyword.

According to various embodiments, the method may be configured to receive a keyword, generate at least one recommended keyword by integrating at least one information/data element in a database defining a plurality of information/data elements and a relation among the plurality of information/data elements, and display the keyword together with the at least one recommended keyword.

According to various embodiments, the method may be configured to display images including the selected recommended keyword in the metadata among images stored in the memory of the electronic device, in response to selecting one of the at least one recommended keyword.

21

According to various embodiments, the method may be configured to produce statistical information about a plurality of metadata stored in the memory of the electronic device and display the statistical information.

According to various embodiments, the service/function may include at least one of image discovery/search services, keyword recommending services, image title providing services, and statistical information providing services.

FIG. 5 is a flowchart illustrating a metadata processing method on an electronic device according to various embodiments. The metadata processing method of the electronic device may include operations 510 to 540. The metadata processing method of the electronic device may be performed by at least one of the electronic device (e.g., the electronic device 101, 201, or 401) or a controller or processor (e.g., the processor 120, 210, or 410) of the electronic device.

In operation 510, the electronic device may obtain images.

In one embodiment, the electronic device may obtain an image for an object using a camera (e.g., the camera module 291 or camera 490) functionally connected with the electronic device.

In one embodiment, when/while the image is captured, the electronic device may display, in real-time, the image on a display (e.g., the display 160, 260, or 460) functionally connected with the electronic device or a first area (or a first screen area or first window) of the display.

In one embodiment, the capture of the image may be initiated by receiving a capture command from the user or automatically according to the setting information stored in a memory (e.g., the memory 130, 230, or 430) functionally connected with the electronic device.

In one embodiment, the end of the image capture may be performed by receiving a capture end command from the user or automatically according to the setting information stored in the memory. For example, the electronic device may recommend the capture command and/or the capture end command through an input device (e.g., at least one of the input device 250, the display 160, 260, or 460, the microphone 288, the sensor module 240, or the sensor 440).

In one embodiment, the electronic device may read the image from the memory functionally connected with the electronic device.

In one embodiment, the electronic device may receive the image from an external device (e.g., the electronic device 102 or 104 or the server 106) through a communication module (e.g., the communication module 170, 220, or 420) functionally connected with the electronic device.

In operation 520, the electronic device may integrate recognition information about the image with the image-related information.

In one embodiment, the electronic device may incorporate the recognition information about the image with the image-related information based on a first database (e.g., at least one of the ontology database 411 or the metadata model database 413) defining a plurality of information/data elements and relations among the plurality of information/data elements.

In one embodiment, the recognition information may include at least one of identification information about the

22

user included in the image, identification information about a thing included in the image, composition information about objects included in the image, information about text included in the image, and color/chroma/lightness/brightness information about the image.

In one embodiment, the electronic device may recognize information contained in the image based on a second database (e.g., the target database 414) stored in the memory.

In one embodiment, the electronic device may transmit the image and/or information related to the image to an external device (e.g., the first external electronic device 102, the second external electronic device 104, or the server 106) and receive recognition information about the image from the external device.

In one embodiment, the image-related information may include at least one of context information indicating the capture context/condition for the image, user input information, and search information using an external database/system/network.

In one embodiment, the context information may include at least one of time or location captured, ambient sounds when/while being captured, or setting information about the camera when/while being captured.

In one embodiment, the electronic device may detect context information (e.g., at least one of the time or location/place captured or ambient sounds when/while being captured) indicating the capture context/condition for the image through the communication module or a sensor (e.g., at least one of the sensor 440, the sensor module 240, the touch panel 252, the GNSS module 227, or the microphone 288).

In one embodiment, the electronic device may detect user input information (e.g., at least one of the title, tag, and memo of the image) related to the image through the sensor or the display.

In one embodiment, the electronic device may detect setting information about the camera 490 when/while the image is captured through the camera or the memory.

In one embodiment, the setting information may include at least one of capture start/end/whole time information, capture mode information (e.g., at least one of a nighttime mode, a figure mode, an indoor mode, a facial recognition mode, or a panoramic mode), information about a section/area/portion-of-interest information, or capture rate (or frame rate) information.

In operation 530, the electronic device may store the integrated information, as metadata of the image, in the memory, a third database (e.g., the image/metadata database 412), or the first database (e.g., at least one of the ontology database 411 or the metadata model database 413).

In one embodiment, the electronic device may store the metadata in one image file corresponding to the image.

In one embodiment, the electronic device may store the metadata in a separate file related to the one image file corresponding to the image.

The third database (e.g., the image/metadata database 412) may have various data structures and may store a plurality of metadata in the form of multiple records as set forth below in Table 3 below, for example.

TABLE 3

Image Identification information	Object Identification information	Composition Information	Context Information	User Input information	Image Description information
F1	G1	H1	I1	J1	K1
F2	G2	H2	I2	J2	K2
...
F _n	G _n	H _n	I _n	J _m	K _m

Each record in the image/metadata database 412 may include fields, such as image identification information F_i (1 ≤ i ≤ n, where n is an integer not less than 1), object identification information G_i, composition information H_i, context information I_i, user input information J_i, and image description information K_i.

The image identification information F_i may include at least one information piece, such as image name, image ID, or location of image stored. The object identification information G_i may include at least one information piece, such as object type/category, object name/ID, or object recognition rate (or recognition accuracy). The composition information H_i may include at least one information piece, such as number of objects, object type, object position/size, object direction, category of whole scene, or recognition rate (or recognition accuracy) of composition information. The context information I_i may include at least one information piece, such as target, time, or location/place captured, ambient sounds when/while being captured, and information searched in relation with the image. The user input information J_i may include at least one information piece, such as image title, tag, or memo. The image description information (or estimation information) may include at least one information piece, such as image title, description of object/scene/context, or estimation accuracy. Each field may have one or more values; each value may be, e.g., a constant, coordinate, vector, matrix, or text.

In one embodiment, unless the object recognized is one registered in the second database (e.g., the target database 414), the electronic device may display, on the display, a GUI for inquiring the user about identification information such as the type or name of the object, detect a user input (i.e., identification information such as type or name of object) on the GUI, and store the detected user input as the object identification information G_i. Further, the electronic device may assign an object ID to the detected user input and register the object ID and the detected user ID in the second database.

In one embodiment, the electronic device may integrate at least part of the composition information H_i and the object identification information G_i with at least part of the user input information J_i and the context information I_i and produce/estimate the image description information K_i based on the integrated information.

In operation 540, the electronic device may provide services or functions using the metadata (or the integrated information).

In one embodiment, the services or functions may include at least one of image discovery/search services, keyword recommending services, image title/description providing statistical information providing services, or database update functions/services.

In one embodiment, any one of operations 530 and 540 may be omitted or may be performed in the reverse order.

In one embodiment, operation 530 may correspond to one of image discovery/search services, keyword recommending

services, image title/description providing services, statistical information providing services, or database update functions.

According to various embodiments, an operation method of an electronic device may comprise obtaining an image, integrating recognition information about the image with information related to the image, and storing the integrated information as metadata of the image or providing a service or a function using the integrated information.

According to various embodiments, integrating the recognition information with the image-related information may include integrating the recognition information with the image-related information based on a database defining a plurality of information/data elements and a relation among the plurality of information/data elements.

According to various embodiments, the method may include at least one of receiving the image from external device, obtaining the image through capturing by a camera of the electronic device, and reading the image stored in a memory of the electronic device.

According to various embodiments, the method may include recognizing an object from the image and receiving information about the recognized object from the user.

According to various embodiments, the method may include recognizing an object from the image and storing information about the recognized object and information about a recognition accuracy/rate in the memory of the electronic device.

According to various embodiments, the method may include recognizing an object from the image and searching the memory of the electronic device for information about the recognized object.

According to various embodiments, the method may include transmitting the image to an external device and receiving recognition information about the image from the external device.

According to various embodiments, the method may include accessing an external database/system/network, searching the database/system/network for information about at least part of the image-related information or the image information, and storing the searched-for information as part of the image-related information.

According to various embodiments, the image-related information may include text. The method may include splitting the text into a plurality of text elements based on a database defining a plurality of information/data elements and a relation among the plurality of information/data elements and allowing the plurality of text elements to correspond to categories/topics/classes in the database.

According to various embodiments, the method may include producing information (or values) indicating the relevancy among the information/data elements in a plurality of metadata stored in the memory of the electronic device.

According to various embodiments, the method may include determining whether a preset condition is met, and

upon meeting the preset condition, producing values indicating the relevancy among the information/data elements in a plurality of metadata stored in the memory of the electronic device.

According to various embodiments, the method may include determining whether a preset condition is met, upon meeting the preset condition, producing values indicating the relevancy among the information/data elements for a plurality of metadata stored in the memory of the electronic device and storing the produced values as a data model.

According to various embodiments, the method may be configured to determine whether a preset condition is met, and upon meeting the preset condition, produce values indicating the relevancy among the information/data elements for a plurality of metadata stored in the memory of the electronic device. The preset condition may include at least one of arrival of a preset period, the usage of computing resources of the electronic device being not more than a preset threshold, the remaining battery life of the electronic device being not less than a preset threshold, the passage of a preset time from the last time that a metadata model was produced, the number of new images obtained being not less than a preset threshold, providing a service or function using metadata, receiving a user input, the electronic device booting up, a transition from a sleep mode of the electronic device to a normal mode, the display screen/power-on after entry into the sleep mode of the electronic device, executing an application including a graphical element (or item) (e.g., at least one of a button, icon, menu, or menu item) requiring a metadata model, displaying a screen including a graphical element requiring a metadata model, the user's approach to a graphical element requiring a metadata model, detecting a context associated with the electronic device that matches a preset context, or detecting at least one word matching at least one preset word.

According to various embodiments, the method may include estimating information about the image based on values indicating the relevancy among the information/data elements for a plurality of metadata stored in the memory of the electronic device.

According to various embodiments, the method may include updating a database defining a plurality of information/data elements and a relation among the plurality of information/data elements using at least part of the recognition information or the image-related information.

According to various embodiments, the method may include receiving at least part of a database defining a plurality of information/data elements and a relation among the plurality of information/data elements from an external device.

According to various embodiments, the method may include determining whether a preset condition is met, and upon meeting the preset condition, transmitting at least part of a database defining a plurality of information/data elements and a relation among the plurality of information/data elements to the external device.

According to various embodiments, the method may include classifying images stored in the memory of the electronic device into a plurality of categories based on a database defining a plurality of information/data elements and a relation among the plurality of information/data elements and metadata of the images, and upon selecting one of the plurality of categories, displaying images belonging to the selected category.

According to various embodiments, the method may include classifying images stored in the memory of the electronic device into a plurality of categories based on a

database defining a plurality of information/data elements and a relation among the plurality of information/data elements and metadata of the images, upon selecting one of the plurality of categories, displaying images belonging to the selected category, displaying sub-categories belonging to the selected category, and upon selecting one of the sub-categories, displaying images belonging to the selected sub-category.

According to various embodiments, the method may include displaying information/data elements of a first group among a plurality of information/data elements in a database defining the plurality of information/data elements and a relation among the plurality of information/data elements, in response to a first input and displaying images stored in a memory of the electronic device related to a first information/data element among the information/data elements of the first group, in response to a second input.

According to various embodiments, the method may include displaying information/data elements of a second group among the plurality of information/data elements related to the first information/data element, in response to a third input and displaying the images stored in the memory of the electronic device related to the first information/data element and a second information/data element among the information/data elements of the second group, in response to a fourth input.

According to various embodiments, the method may be configured to display, together with the information/data elements of the first group, information/data elements of a third group among the plurality of information/data elements including a third information/data element related to the information/data elements of the first group, in response to the first input.

According to various embodiments, the method may be configured to display, together with the information/data elements of the second group, information/data elements of a fourth group among the plurality of information/data elements including a fourth information/data element related to the information/data elements of the second group, in response to the third input.

According to various embodiments, the method may include integrating the text elements of the metadata based on a database defining a plurality of information/data elements and a relation among the plurality of information/data elements and storing combinations of the text elements as a title of the image.

According to various embodiments, the method may include integrating the text elements of the metadata based on a database defining a plurality of information/data elements and a relation among the plurality of information/data elements, comparing the respective evaluation values for the combinations of the text elements, and determining one of the combinations of the text elements as the title of the image based on the comparison.

According to various embodiments, the method may include receiving a keyword and displaying images including the keyword in the metadata among images stored in the memory of the electronic device, in response to receiving the keyword.

According to various embodiments, the method may include receiving a keyword, generate at least one recommended keyword by integrating at least one information/data element in a database defining a plurality of information/data elements and a relation among the plurality of information/data elements, and displaying the keyword together with the at least one recommended keyword.

According to various embodiments, the method may include displaying images including the selected recommended keyword in the metadata among images stored in the memory of the electronic device, in response to selecting one of the at least one recommended keyword.

According to various embodiments, the method may include producing statistical information about a plurality of metadata stored in the memory of the electronic device and displaying the statistical information.

FIG. 6 is a flowchart illustrating a metadata processing method on an electronic device according to various embodiments. The metadata processing method of the electronic device may include operations 610 to 640. The metadata processing method of the electronic device may be performed by at least one of the electronic device (e.g., the electronic device 101, 201, or 401) or a controller or processor (e.g., the processor 120, 210, or 410) of the electronic device.

In operation 610, the electronic device may obtain images.

In operation 620, the electronic device may gather at least one metadata (or information/data elements) through at least one of a camera (e.g., the camera module 291 or the camera 490), a memory (e.g., the memory 130, 230, or 430), a communication module (e.g., the communication module 170, 220, or 420), or a sensor (e.g., at least one of the sensor 440, the sensor module 240, the touch panel 252, the GNSS module 227, or the microphone 288) functionally connected with the electronic device. For example, the gathered metadata may include recognition information about the image and information related to the image.

In one embodiment, the recognition information may include at least one of identification information about the user included in the image, identification information about a thing included in the image, composition information about objects included in the image, information about text included in the image, and color/chroma/lightness/brightness information about the image.

In one embodiment, the image-related information may include at least one of context information indicating the capture context/condition for the image, user input information, and search information using an external database/system/network.

In operation 630, the electronic device may integrate recognition information about the image with the image-related information.

In one embodiment, the electronic device may incorporate the recognition information about the image with the image-related information based on a first database (e.g., at least one of the ontology database 411 or the metadata model database 413) defining a plurality of information/data elements and relations among the plurality of information/data elements.

In operation 640, the electronic device may store the integrated information, as metadata of the image, in the memory (e.g., at least one of the image/metadata database 412, the ontology database 411, or metadata model database 413) or may provide services or functions using the metadata (or the integrated information).

For example, the first database (e.g., at least one of the ontology database 411 or the metadata model database 413) may include the ontology “[dad]-{married couple}-[mom].” Here, “[dad]” and “[mom]” correspond to information/data elements (or entities), and “[married couple]” corresponds to a relation. Further, the ontology “[dad]-{married couple}-[mom]” may correspond to a general-purpose ontology.

In one embodiment, the electronic device may receive the general-purpose ontology from an external device (e.g., the first external device 102, the second external device 104, or the server 106) through the communication module. The electronic device may store/integrate the general-purpose ontology in/with the first database.

In one embodiment, the electronic device may obtain an image through the camera and receive the tag “my dad Chulsoo, married couple photo” through the sensor from the user. The electronic device may recognize two figures, i.e., an unknown figure and the dad registered in the second database (e.g., the target database 414) based on the second database (the target database 414). The electronic device may tokenize the tag “my dad Chulsoo, married couple photo” into “my”-“dad”-“Chulsoo”-“married couple”-“photo” and produce/derive the updated ontology “[Chulsoo]-{same figure}-[dad]-{married couple}-[mom]” by a named entity recognition (NER) process that enables “dad” and “Chulsoo” to correspond to the categories/topics/classes “figures (or people)” and “names” in the first database. Here, the portion or updated ontology “[Chulsoo]-{same figure}-[dad]” may correspond to a private ontology, and the tokenizing and NER processes may be called natural language understanding (NLU) processes. The electronic device may update the first database by replacing the general-purpose ontology with the private ontology in the first database or adding the private ontology to the general-purpose ontology.

In one embodiment, the electronic device may perceive the unknown figure as the “mom” based on the tag and the first database and register the identification information “mom” and the image or the mom’s portion in the image in the second database. Further, the electronic device may change the tag “my dad Chulsoo, married couple photo” into the tag “my dad Chulsoo, my mom, married couple photo” and may store in the third database (e.g., the image/metadata database 412) or the tag “my dad Chulsoo, my mom, married couple photo,” as separate image description information, in the third database.

In one embodiment, the second database may have dad Chulsoo, mom Younghee registered therein. The electronic device may produce/derive the updated ontology “[Chulsoo]-{same figure}-[dad]-{married couple}-[mom]-{same figure}-[Younghee]” through the tokenizing and NLU processes based on the second database and the tag “my dad Chulsoo, married couple photo.” Further, the electronic device may change the tag “my dad Chulsoo, married couple photo” into the tag “my dad Chulsoo, my mom Younghee, married couple photo” and may store in the third database or the tag “my dad Chulsoo, my mom Younghee, married couple photo,” as separate image description information, in the third database.

In one embodiment, the electronic device may receive the tag “my dad Chulsoo” from the user, and the second database may have dad Chulsoo, mom Younghee registered therein. The electronic device may produce/derive the updated ontology “[Chulsoo]-{same figure}-[dad]-{married couple}-[mom]-{same figure}-[Younghee]” through the tokenizing and NLU processes based on the second database and the tag “my dad Chulsoo.” Further, the electronic device may change the tag “my dad Chulsoo” into the tag “my dad Chulsoo, my mom Younghee” or “my dad Chulsoo, my mom Younghee, married couple photo” and may store in the third database or the tag “my dad Chulsoo, my mom Younghee” or “my dad Chulsoo, my mom Younghee, married couple photo” as separate image description information, in the third database.

In one embodiment, the electronic device may receive the tag “my papa” from the user, and the second database may have dad Chulsoo, mom Younghee registered therein. The electronic device may produce/derive the updated ontology “[Chulsoo]-{same figure}-[papa]-{same figure}-[dad]-{married couple}-[mom]-{same figure}-[Younghee]” through the tokenizing and NLU processes based on the second database and the tag “my papa.” Further, the electronic device may change the tag “my papa” into the tag “my papa Chulsoo, my mom Younghee” or “my papa Chulsoo, my mom Younghee, married couple photo” and may store in the third database or the tag “my papa Chulsoo, my mom Younghee” or “my papa Chulsoo, my mom Younghee, married couple photo” as separate image description information, in the third database. For example, where the electronic device is unable to recognize “papa” in the tokenizing and NLU processes, the electronic device may produce/derive the updated ontology by displaying a GUI including the inquiry “What’s papa?” and receiving the user’s response (e.g., “papa means dad”) to the inquiry.

In one embodiment, the electronic device may obtain an image through the camera and receive the tag “my dad Chulsoo” through the sensor from the user. The electronic device may recognize two figures, i.e., an unknown figure and the dad registered in the second database based on the second database. The electronic device may detect the first context information “daytime” through the sensor or camera and the second context information “home” through the communication module. The electronic device may perceive the unknown figure as the “mom” based on the detected first and second context information and the first database and register the identification information “mom” and the image or the mom’s portion in the image in the second database. The first database may include information (or values) or data model indicating the relevancy among common information/data elements in the plurality of metadata for the plurality of images stored in the third database. For example, the first database may include such information as, e.g., the number of times, frequency, or percentage at which the mom showed up in images captured at home during the daytime or the probability or accuracy of estimation of the figure in the images captured at home during the nighttime as the mom. The electronic device may change the tag “my dad Chulsoo, married couple photo” into the tag “my dad Chulsoo, my mom, married couple photo” or “my dad Chulsoo, my mom, married couple photo captured at home during daytime” and may store in the third database (e.g., the image/metadata database 412) or the tag “my dad Chulsoo, my mom, married couple photo” or “my dad Chulsoo, my mom, married couple photo captured at home during daytime” as separate image description information, in the third database.

FIGS. 7A, 7B, 7C, and 7D are views illustrating a metadata modeling method on an electronic device according to various embodiments.

The metadata modeling method of the electronic device may be performed by at least one of the electronic device (e.g., the electronic device 101, 201, or 401) or a controller or processor (e.g., the processor 120, 210, or 410) of the electronic device.

FIG. 7A illustrates a data structure 701 of a first database (e.g., at least one of the ontology database 411 or the metadata model database 413) stored in the electronic device (or the memory 130, 230, or 430). The first database may include a plurality of categories (or topics/classes) 710, 720,

and 730 and information (or data) elements 711, 712, 713, 721, 722, 731, 732, 733, and 734 belonging to each category 710, 720, and 730.

For example, the figure category 710 may include wife 711, colleague 712, and Philip 713. The place category 720 may include home 721 and company 722. The time category 730 may include morning 731, afternoon 732, evening 733, and night 734.

Referring to FIGS. 7B and 7C, the electronic device may yield information (or values) indicating the relevancy among the information (or data) elements 711, 712, 713, 721, 722, 731, 732, 733, and 734 of the first database among the plurality of metadata for the plurality of images stored in the third database (e.g., the image/metadata database 412). For example, the electronic device may calculate the number of images related to all of three information elements. Referring to a first metadata model 702 shown in FIG. 7B, it may be shown that the number of images related to morning 731, colleague 712, and company 722 is 21. Referring to a second metadata model 702 shown in FIG. 7C, it may be shown that the number of images related to evening 733, home 721, and wife 711 is 67.

In one embodiment, the electronic device may determine the accuracy of estimation of any one of morning 731, colleague 712, and company 722 or any one of evening 733, home 721, and wife 711 considering, e.g., the ratio of the calculated number of images to the total number of the images.

Referring to FIG. 7D, it can be shown that the metadata 740 of a first photo stored in the third database includes colleague 712 in the figure category 710 and morning 731 in the time category 730 but not the information elements in the place category 720. For example, the electronic device may estimate the information element of the place category 720 as company 722 based on the first metadata model 702.

It can be shown that the metadata 750 of a second photo stored in the third database includes evening 733 in the time category 730 and home 721 in the place category 720 but not the information elements in the figure category 710. For example, the electronic device may estimate the information element of the figure category 710 as wife 711 based on the second metadata model 703.

In one embodiment, upon being unable to obtain the metadata (or information/data element) of a particular category for an image, the electronic device may estimate the metadata of the particular category for the image using the metadata (or information/data elements) of the particular category for other images gathered by the electronic device. Or, upon failing to obtain the metadata (or information/data element) of a particular category for an image, the electronic device may estimate the metadata of the particular category for the image using a metadata model (e.g., the metadata model 702 or 703) or a metadata model database (e.g., the metadata model database 413).

In one embodiment, the electronic device may modify the recognition information about the image based on the first database. For example, the electronic device may perceive the figure in the image as the wife based on the second database (the target database 414) and determine that the accuracy is 50%. For example, upon estimating the figure in the image as the wife based on the first database, the electronic device may increase the accuracy. For example, upon estimating the figure in the image as the colleague based on the first database, the electronic device may reduce the accuracy or make a modification so that the figure in the image is the colleague.

FIG. 8 is a view illustrating an image classifying method on an electronic device according to various embodiments.

The image classifying method of the electronic device may be performed by at least one of the electronic device (e.g., the electronic device 101, 201, or 401) or a controller or processor (e.g., the processor 120, 210, or 410) of the electronic device.

The electronic device may link and diagram the plurality of images 801 stored in the third database (e.g., the image/metadata database 412) according to the corresponding metadata.

The electronic device may classify the plurality of images stored in the third database based on the data structure (e.g., the data structure 701) of the first database (e.g., at least one of the ontology database 411 or the metadata model database 413) stored in the electronic device (or memory 130, 230, or 430). The electronic device may classify the plurality of images according to the categories/topics/classes (e.g., the categories 710, 720, and 730) of the first database. For example, the electronic device may classify the plurality of images into figure categories 811 to 814 (e.g., the figure category 710) and place categories 821 to 824 (e.g., the place category 720). Further, the electronic device may set the information/data elements (e.g., information/data elements 711, 712, 713, 721, 722, 731, 732, 733, and 734) of the first database as sub categories and classify the plurality of images in each category according to the sub categories. For example, the electronic device may classify the images of the figure categories 811 to 814 into a mom category 811, a dad category 812, a Muzie category 813, and a how-on-earth category 814. For example, the electronic device may classify the images of the place categories 821 to 824 into an abroad category 821, a Jeju Island category 822, a Muzie's home category 823, and a secret place category 824.

FIG. 9 is a flowchart illustrating image search method on an electronic device according to various embodiments. The image search method of the electronic device may include operations 910 to 940. The image search method of the electronic device may be performed by at least one of the electronic device (e.g., the electronic device 101, 201, or 401) or a controller or processor (e.g., the processor 120, 210, or 410) of the electronic device.

In operation 910, in response to a first input, the electronic device may display, on a display (e.g., the display 160, 260, or 460) functionally connected with the electronic device, information/data elements of a first and/or second group among the plurality of information/data elements in the first database (e.g., at least one of the ontology database 411 or the metadata model database 413) stored in the electronic device (or memory 130, 230, or 430).

In one embodiment, in response to the first input, the electronic device may display the information/data elements of the first group on a first area (or first screen area or first window) of the display. The plurality of information/data elements may be related to a plurality of metadata for the plurality of images stored in the electronic device (or the memory 130, 230, or 430) or the third database (e.g., the image/metadata database 412).

For example, the first input may be received through an input device (e.g., at least one of the input device 250, the display 160, 260, or 460, the microphone 288, the sensor module 240, or the sensor 440) of the electronic device.

For example, the first input may be a touch input for selecting an icon displayed on the display.

In one embodiment, the electronic device may display the information/data elements of the first group on a first graphical element that, as rotated, allows any one thereof to be selectable.

In one embodiment, the electronic device may display, on a second area (or second screen area or second window) of the display, the information/data elements of the second group among the plurality of information/data elements related to the first information/data element among the information/data elements of the first group. For example, the first graphical element may be overlaid on the second area transparently/semi-transparently/opaque.

For example, in response to a user input of rotating the first graphical element, the electronic device may display, on the second area, the information/data elements of the corresponding group related to the information/data element selected as per the rotation among the information/data elements of the first group.

In operation 920, in response to a second input, the electronic device may display, on the second area (or a third area), images related to the second information/data element among the information/data elements of the second group. For example, the second input may be a touch input of selecting the second information/data element.

In operation 930, in response to a third input, the electronic device may display, on the first area, information/data elements of the third group among the plurality of information/data elements related to the second information/data element.

For example, the third input may be a swipe gesture of a preset pattern (e.g., L-shaped or C-shaped) on the second area (or third area).

In one embodiment, the electronic device may display the information/data elements of the third group on a second graphical element that, as rotated, allows any one thereof to be selectable.

In one embodiment, the electronic device may display, on the second area of the display, the information/data elements of a fourth group among the plurality of information/data elements related to the third information/data element among the information/data elements of the third group.

For example, the second graphical element may be overlaid on the second area transparently/semi-transparently/opaque.

For example, in response to a user input of rotating the second graphical element, the electronic device may display, on the second area, the information/data elements of the corresponding group related to the information/data element selected as per the rotation among the information/data elements of the third group.

In operation 940, in response to a fourth input, the electronic device may display, on the second area (or the third area), images related to the second information/data element and the fourth information/data element among the information/data elements of the fourth group. For example, the fourth input may be a touch input of selecting the fourth information/data element.

FIGS. 10A, 10B, 10C, and 10D are views illustrating an image search method on an electronic device according to various embodiments. The image search method of the electronic device may be performed by at least one of the electronic device (e.g., the electronic device 101, 201, or 401) or a controller or processor (e.g., the processor 120, 210, or 410) of the electronic device.

Referring to FIG. 10A, in response to a first input, the electronic device may display, on a display (e.g., the display 160, 260, or 460) functionally connected with the electronic

device, information/data elements **1031** to **1034** of a first group (e.g., categories/topics/classes) and information/data elements **1011** to **1014** of a second group (e.g., the figure categories **710** and **811** to **814** among the plurality of information/data elements in the first database (e.g., at least one of the ontology database **411** or the metadata model database **413**) stored in the electronic device (or memory **130**, **230**, or **430**).

In response to the first input, the electronic device may display the information/data elements **1031** to **1034** of the first group on a first area (or first screen area or first window) of the display. The plurality of information/data elements may be related to a plurality of metadata for the plurality of images stored in the electronic device (or the memory **130**, **230**, or **430**) or the third database (e.g., the image/metadata database **412**).

For example, the information/data elements **1031** to **1034** of the first group may include FIG. **1031**, place **1032**, time **1033**, and thing **1034**, and the information/data elements **1011** to **1014** of the second group may include with mom **1011**, with dad **1012**, with Muzie **1013**, and how on earth **1014**.

For example, the first input may be received through an input device (e.g., at least one of the input device **250**, the display **160**, **260**, or **460**, the microphone **288**, the sensor module **240**, or the sensor **440**) of the electronic device. For example, the first input may be a touch input for selecting an icon displayed on the display.

The electronic device may display the information/data elements **1031** to **1034** of the first group on a first graphical element that, as rotated, allows any one thereof to automatically be selected.

The electronic device may display the information/data elements **1011** to **1014** of the second group related to the FIG. **1031** among the information/data elements **1031** to **1034** of the first group on a second area **1001** (or second screen area or second window) of the display. For example, the second area **1001** may correspond to the overall display area of the display. For example, the first graphical element **1030** may be overlaid on the second area **1001** transparently/semi-transparently/opaquely.

For example, in response to a user input of rotating the first graphical element **1030**, the electronic device may display, on the second area **1001**, the information/data elements of the corresponding group related to the information/data element selected as per the rotation among the information/data elements of the first group.

The electronic device may display representative images **1021**, **1022**, **1023**, and **1024** respectively associated with the information/data elements **1011** to **1014** of the second group, along with the information/data elements **1011** to **1014** of the second group. For example, the electronic device may display the corresponding representative images **1021**, **1022**, **1023**, and **1024** most relevant to the information/data elements **1011** to **1014**, respectively, of the second group, along with the information/data elements **1011** to **1014**, respectively.

In one embodiment, the electronic device may sequentially or automatically display the images related with the information/data elements **1011** to **1014**, respectively, of the second group.

Referring to FIG. **10B**, in response to a second input, the electronic device may display, on the second area **1001**, images **1041** and **1042** related to the second information/data element **1013** among the information/data elements **1011** to **1014** of the second group. For example, in response to a second input, the electronic device may display, on the

second area **1001**, images **1041** and **1042** having the meta-data containing the second information/data element **1013** among the plurality of images. For example, the electronic device may first display images with a high accuracy of matching with the second information/data element **1013** among the images **1041** and **1042** having the metadata containing the second information/data element **1013**.

For example, the second input may be a touch input of selecting the second information/data element **1013**.

Referring to FIG. **10C**, in response to a third input, the electronic device may display, on the display, information/data elements **1051** to **1054** of a fourth group (e.g., the place categories **720** and **821** to **824**) and the information/data elements **1032**, **1033**, **1061**, and **1064** of the third group (e.g., the categories/topics/classes **710**, **720**, and **730**) among the plurality of information/data elements related to the second information/data element **1013**.

The electronic device may display the information/data elements **1032**, **1033**, **1061**, and **1064** of the third group on the first area in response to the third input.

For example, the information/data elements **1032**, **1033**, **1061**, and **1064** of the third group may include season **1061**, place **1032**, time **1033**, and monthly **1064**, and the information/data elements **1051** to **1054** of the fourth group may include abroad **1051** Jeju Island **1052**, Muzie's home **1053**, and secret place **1054**.

For example, the third input may be a swipe gesture of a preset pattern (e.g., L-shaped or C-shaped) on the second area **1001**.

In one embodiment, the electronic device may display the information/data elements **1032**, **1033**, **1061**, and **1064** of the third group on a second graphical element that, as rotated, allows any one thereof to be selected.

In one embodiment, the electronic device may display, on the second area **1001**, the information/data elements **1051** to **1054** of the fourth group related to the third information/data element **1032** among the information/data elements **1032**, **1033**, **1061**, and **1064** of the third group.

For example, the second graphical element **1060** may be overlaid on the second area **1001** transparently/semi-transparently/opaquely.

For example, in response to a user input of rotating the second graphical element **1060**, the electronic device may display, on the second area **1001**, the information/data elements of the corresponding group related to the information/data element selected as per the rotation among the information/data elements **1032**, **1033**, **1061**, and **1064** of the third group.

The electronic device may display representative images **1025**, **1026**, **1027**, and **1028** respectively associated with the information/data elements **1051** to **1054** of the fourth group, along with the information/data elements **1051** to **1054** of the fourth group. For example, the electronic device may display the corresponding representative images **1025**, **1026**, **1027**, and **1028** most relevant to the information/data elements **1051** to **1054**, respectively, of the fourth group, along with the information/data elements **1051** to **1054**, respectively.

In one embodiment, the electronic device may sequentially or automatically display the images related with the information/data elements **1051** to **1054**, respectively, of the fourth group.

Referring to FIG. **10D**, in response to a fourth input, the electronic device may display, on the second area **1001**, images **1071** and **1072** related to the second information/data element **1053** (and the second information/data element **1013**) among the information/data elements **1051** to **1054** of

the fourth group. For example, the fourth input may be a touch input of selecting the fourth information/data element **1053**. For example, the electronic device may first display images with a high accuracy of matching with the second information/data element **1013** and the fourth information/data element **1053** among the images **1071** and **1072** having the metadata containing the second information/data element **1013** and the fourth information/data element **1053**.

FIG. **11** is a flowchart illustrating image search method on an electronic device according to various embodiments. The image search method of the electronic device may include operations **1110** to **1130**. The image search method of the electronic device may be performed by at least one of the electronic device (e.g., the electronic device **101**, **201**, or **401**) or a controller or processor (e.g., the processor **120**, **210**, or **410**) of the electronic device.

In operation **1110**, in response to a first input, the electronic device may display an image search application (or application screen/GUI) on a display (e.g., the display **160**, **260**, or **460**) functionally connected with the electronic device.

For example, the first input may be received through an input device (e.g., at least one of the input device **250**, the display **160**, **260**, or **460**, the microphone **288**, the sensor module **240**, or the sensor **440**) of the electronic device.

For example, the first input may be a touch input for selecting an icon displayed on the display.

In one embodiment, operation **1110** may be omitted. For example, the electronic device may detect a user input on a home screen, voice recognition screen, or search screen.

In operation **1120**, in response to entry of a keyword, the electronic device may produce at least one recommended keyword by integrating the keyword with each of at least one information/data element in the first database (e.g., at least one of the ontology database **411** or the metadata model database **413**) stored in the electronic device (or memory **130**, **230**, or **430**). The electronic device may display the keyword and the at least one recommended keyword together on the display.

In operation **1130**, in response to a second input, the electronic device may display, on the display, images in which one selected from among the at least one recommended keyword is contained in the metadata among the images stored in the electronic device (or memory **130**, **230**, or **430**). For example, the second input may be a touch input of selecting one of the at least one recommended keyword.

FIGS. **12A** and **12B** are views illustrating an image search method on an electronic device according to various embodiments. The image search method of the electronic device **1201** may be performed by at least one of the electronic device **1201** (e.g., the electronic device **101**, **201**, or **401**) or a controller or processor (e.g., the processor **120**, **210**, or **410**) of the electronic device **1201**.

Referring to FIG. **12A**, in response to a first input, the electronic device **1201** may display an image search application **1210** (or application screen/GUI) on a display **1206** (e.g., the display **160**, **260**, or **460**) functionally connected with the electronic device **1201**. For example, the first input may be received through an input device (e.g., at least one of the input device **250**, the display **160**, **260**, or **460**, the microphone **288**, the sensor module **240**, or the sensor **440**) of the electronic device **1201**. For example, the first input may be a touch input for selecting an icon displayed on the display **1206**.

The image search application **1210** may include a search window for receiving keywords from the user.

For example, the electronic device **1201** may receive a keyword **1220** (e.g., Muzie) from the user through the search window **1212**.

In response to entry of the keyword **1220**, the electronic device **1201** may produce at least one recommended keyword **1231**, **1232**, and **1233** by integrating the keyword **1220** with each of at least one information/data element (e.g., Muzie's home, morning, or Christmas) in the first database (e.g., at least one of the ontology database **411** or the metadata model database **413**) stored in the electronic device **1201** (or memory **130**, **230**, or **430**). For example, the at least one recommended keyword **1231**, **1232**, and **1233** may include at Muzie's home **1231**, with Muzie in the morning **1232**, and with Muzie at Christmas **1233**. The electronic device **1201** may display the keyword **1220** along with the at least one recommended keyword **1231**, **1232**, and **1233** on the display **1206**.

Referring to FIG. **12B**, in response to a second input, the electronic device **1201** may display, on the display **1206**, images **1241** and **1242** in which one (e.g., Muzie's home) selected from among the at least one recommended keyword **1231**, **1232**, and **1233** is contained in the metadata among the images stored in the electronic device **1201** (or memory **130**, **230**, or **430**). For example, the second input may be a touch input of selecting one of the at least one recommended keyword **1231**, **1232**, and **1233**. For example, the electronic device **1201** may first display images with a high accuracy of matching with one (e.g., Muzie's home) selected from among the at least one recommended keyword **1231**, **1232**, and **1233** among the images **1241** and **1242** having the metadata containing one (e.g., Muzie's home) selected from among the at least one recommended keyword **1231**, **1232**, and **1233**.

FIG. **13** is a flowchart illustrating an image title determining method on an electronic device according to various embodiments. The image title determining method of the electronic device may include operations **1310** to **1340**. The image title determining method of the electronic device may be performed by at least one of the electronic device (e.g., the electronic device **101**, **201**, or **401**) or a controller or processor (e.g., the processor **120**, **210**, or **410**) of the electronic device.

In operation **1310**, the electronic device may obtain images.

In one embodiment, the electronic device may obtain an image for an object using a camera (e.g., the camera module **291** or camera **490**) functionally connected with the electronic device.

In one embodiment, when/while the image is captured, the electronic device may display, in real-time, the image on a display (e.g., the display **160**, **260**, or **460**) functionally connected with the electronic device or a first area (or a first screen area or first window) of the display.

In one embodiment, the capture of the image may be initiated by receiving a capture command from the user or automatically according to the setting information stored in a memory (e.g., the memory **130**, **230**, or **430**) functionally connected with the electronic device.

In one embodiment, the end of the image capture may be performed by receiving a capture end command from the user or automatically according to the setting information stored in the memory. For example, the electronic device may recommend the capture command and/or the capture end command through an input device (e.g., at least one of the input device **250**, the display **160**, **260**, or **460**, the microphone **288**, the sensor module **240**, or the sensor **440**).

In one embodiment, the electronic device may read the image from the memory functionally connected with the electronic device.

In one embodiment, the electronic device may receive the image from an external device (e.g., the electronic device **102** or **104** or the server **106**) through a communication module (e.g., the communication module **170**, **220**, or **420**) functionally connected with the electronic device.

In operation **1320**, the electronic device may integrate the text elements of the metadata for the image stored in the memory or third database (e.g., the image/metadata database **412**).

In one embodiment, the electronic device may incorporate the text elements of the metadata for the image based on a first database (e.g., at least one of the ontology database **411** or the metadata model database **413**) defining a plurality of information/data elements and relations among the plurality of information/data elements.

For example, the first database may include the relations among the text elements and weights for the relations. For example, the weights may be determined by, e.g., the number of times, frequency, and percentage at which combinations of the text elements show up in the plurality of metadata stored in the memory or the third database.

In operation **1330**, the electronic device may compare the respective evaluation values for the combinations of the text elements. For example, the evaluation value of each combination may be determined as the sum of the relation weight(s) of the text elements included in each combination.

In operation **1340**, the electronic device may determine one of the combinations of the text elements as the title of the image based on the comparison. The electronic device may include the determined title in the metadata of the image.

FIGS. **14A** and **14B** are views illustrating an image title determining method on an electronic device according to various embodiments. The image title determining method of the electronic device may be performed by at least one of the electronic device (e.g., the electronic device **101**, **201**, or **401**) or a controller or processor (e.g., the processor **120**, **210**, or **410**) of the electronic device.

Referring to FIG. **14A**, the electronic device may integrate text elements **1422** to **1428** of the metadata for the image stored in a memory (e.g., the memory **130**, **230**, or **430**) or the third database (e.g., the image/metadata database **412**) functionally connected with the electronic device based on the first database (e.g., at least one of the ontology database **411** or the metadata model database **413**) defining a plurality of information/data elements **1411** to **1428** and the relation among the plurality of information/data elements **1411** to **1428**.

For example, the first database may include a plurality of categories/topics/classes **1411** to **1417** and the information/data elements **1422** to **1428** belonging to the categories/topics/classes **1411** to **1417**, respectively. Further, the first database may include the relations among the plurality of categories/topics/classes **1411** to **1417** and weights for the relations. For example, the plurality of categories/topics/classes **1411** to **1417** may include year **1411**, weather **1413**, season **1415**, and number of people **1417**, and the information/data elements **1422** to **1428** may include last year **1422**, clear day **1424**, spring **1426**, and alone **1428** (or a photo taken alone). For example, the relation between year **1411** and weather **1413**, the relation between year **1411** and number of people **1417**, the relation between weather **1413** and number of people **1417**, and the relation between season **1415** and number of people **1417** each may be assigned a

weight of 3, and the relation between year **1411** and weather **1415** and the relation between weather **1413** and season **1415** each may be assigned a weight of 2.

Referring to FIG. **14B**, the electronic device may compare the respective evaluation values for the combinations **1432** to **1438** of the text elements **1422** to **1428**. For example, the evaluation value of each combination **1432** to **1438** may be determined as the sum of the relation weight(s) of the text elements **1422** to **1428** included in each combination. For example, the evaluation value for a photo **1432** taken alone last year may be 3, the evaluation value for a photo **1434** taken alone in the last spring may be 5, the evaluation value for a photo **1436** taken alone on a clear day last year may be 6, and the evaluation value for a photo **1438** taken alone on a clear day in the last spring may be 8.

The electronic device may determine one of the combinations **1432** to **1438** of the text elements **1422** to **1428** as the title of the image based on the comparison. For example, the electronic device may determine that among the combinations **1432** to **1438**, the one with the highest evaluation value, i.e., the photo **1438** taken alone on a clear day last year, is the title of the image.

The electronic device may include the determined title in the metadata of the image.

In one embodiment, the electronic device may display the combinations **1432** to **1438** (and the image) on a display (e.g., the display **160**, **260**, or **460**) functionally connected with the electronic device and may determine the selected combination as the title of the image according to a user input of selecting one of the combinations **1432** to **1438**.

FIGS. **15A**, **15B**, and **15C** are views illustrating a statistical information providing method on an electronic device according to various embodiments. The statistical information providing method of the electronic device may be performed by at least one of the electronic device (e.g., the electronic device **101**, **201**, or **401**) or a controller or processor (e.g., the processor **120**, **210**, or **410**) of the electronic device.

Referring to FIG. **15A**, the electronic device may yield statistical information **1510** about the number of portraits for a plurality of metadata stored in the third database (e.g., the image/metadata database **412**) or a memory (e.g., the memory **130**, **230**, or **430**) functionally connected with the electronic device and display the statistical information **1510** on a display (e.g., the display **160**, **260**, or **460**) functionally connected with the electronic device.

The electronic device may produce and display count statistical information **1510** about photos including, as metadata, information/data elements (e.g., with mom **1011**, with dad, with Muzie **1013**, and how on earth **1014**) of the first database (e.g., at least one of the ontology database **411** or metadata model database **413**) stored in the electronic device (or memory **130**, **230**, or **430**).

Referring to FIG. **15B**, the electronic device may produce statistical information **1520** about a ratio of photos in a preferred place for the plurality of metadata and display the produced statistical information **1520** on the display.

The electronic device may produce and display ratio statistical information **1520** about photos including, as metadata, information/data elements (e.g., at least one of abroad **1051**, Jeju Island **1052**, Muzie's home **1053**, and secret place **1054**) of the first database.

Referring to FIG. **15C**, the electronic device may produce monthly variation statistical information **1530** about capturing time zones for the plurality of metadata and display the produced statistical information **1530** on the display.

The electronic device may produce and display monthly time zone variation statistical information **1530** about photos including, as metadata, information/data elements (e.g., at least one of morning **731**, afternoon **732**, evening **733**, and night **734**) of the first database.

FIG. **16** is a flowchart illustrating a metadata model producing method on an electronic device according to various embodiments. The metadata model producing method of the electronic device may include operations **1610** to **1630**. The metadata model producing method of the electronic device may be performed by at least one of the electronic device (e.g., the electronic device **101**, **201**, or **401**) or a controller or processor (e.g., the processor **120**, **210**, or **410**) of the electronic device.

In operation **1610**, the electronic device may determine whether preset conditions are met. The electronic device may perform operation **1620** upon meeting the preset conditions, or otherwise upon failing to meet the preset conditions, periodically/aperiodically repeat operation **1610**.

For example, the preset conditions may include at least one of arrival of a preset period, the usage of computing resources of the electronic device being not more than a preset threshold, the remaining battery life of the electronic device being not less than a preset threshold, the passage of a preset time from the last time that a metadata model was produced, the number of new images obtained being not less than a preset threshold, providing a service or function using metadata, receiving a user input, the electronic device booting up, a transition from a sleep mode of the electronic device to a normal mode, the display screen/power-on after entry into the sleep mode of the electronic device, executing an application including a graphical element (or item) (e.g., at least one of a button, icon, menu, or menu item) requiring a metadata model, displaying a screen including a graphical element requiring a metadata model, the user's approach to a graphical element requiring a metadata model, detecting a context associated with the electronic device that matches a preset context, or detecting at least one word matching at least one preset word.

In one embodiment, the preset context for the electronic device may include at least one of the electronic device being positioned or reaching a preset area/place, reaching a preset time, the electronic device operating as per a preset operation pattern (e.g., executing an application(s)), or the current status (e.g., at least one of the battery status, wireless signal reception status, or memory status) of the electronic device matching a preset status.

In one embodiment, the preset context for the electronic device may be determined based on the use history information (e.g., the history of the electronic device having operated in the sleep mode in a particular place) about the electronic device.

In operation **1620**, the electronic device may produce information (or values) indicating the relevancy among information/data elements for a plurality of metadata stored in the third database (e.g., the image/metadata database **412**) or a memory (e.g., the memory **130**, **230**, or **430**) functionally connected with the electronic device. The electronic device may produce the information (or values) indicating the relevancy among the information/data elements based on the first database (e.g., at least one of the ontology database **411** or the metadata model database **413**) defining the plurality of information/data elements and relations among the plurality of information/data elements.

In operation **1630**, the electronic device may store the produced information (or values) as metadata models (e.g.,

the metadata models **702** and **704**). For example, the electronic device may store the metadata models in the first database.

FIG. **17** is a flowchart illustrating an ontology update/backup method on an electronic device according to various embodiments. The ontology update/backup method of the electronic device may include operations **1710** and **1720**. The ontology update/backup method of the electronic device may be performed by at least one of the electronic device (e.g., the electronic device **101**, **201**, or **401**) or a controller or processor (e.g., the processor **120**, **210**, or **410**) of the electronic device.

In operation **1710**, the electronic device may determine whether preset conditions are met. The electronic device may perform operation **1720** upon meeting the preset conditions, or otherwise upon failing to meet the preset conditions, periodically/aperiodically repeat operation **1710**.

For example, the preset conditions may include at least one of arrival of a preset period, the usage of computing resources of the electronic device being not more than a preset threshold, the remaining battery life of the electronic device being not less than a preset threshold, the passage of a preset time from the last time that the ontology was updated/backed up, receiving an update/backup request from an external device (e.g., the first external electronic device **102**, the second external electronic device **104**, or the server **106**), providing a service or function using an ontology, receiving a user input, the electronic device booting up, a transition from a sleep mode of the electronic device to a normal mode, the display screen/power-on after entry into the sleep mode of the electronic device, executing an application including a graphical element (or item) (e.g., at least one of a button, icon, menu, or menu item) requiring an ontology, displaying a screen including a graphical element requiring an ontology, the user's approach to a graphical element requiring an ontology, detecting a context associated with the electronic device that matches a preset context, or detecting at least one word matching at least one preset word.

In operation **1720**, the electronic device may update the ontology or ontology database (e.g., the ontology database **411**) or may back up the ontology or ontology database in an external device (e.g., the first external electronic device **102**, the second external electronic device **104**, or the server **106**, ontology cloud storage). For example, the electronic device may receive a general-purpose ontology from the external device and integrate the received general-purpose ontology with a personal ontology.

The term 'module' may refer to a unit including one of hardware, software, and firmware, or a combination thereof. The term 'module' may be interchangeably used with a unit, logic, logical block, component, or circuit. The module may be a minimum unit or part of an integrated component. The module may be a minimum unit or part of performing one or more functions. The module may be implemented mechanically or electronically. For example, the module may include at least one of Application Specific Integrated Circuit (ASIC) chips, Field Programmable Gate Arrays (FPGAs), or Programmable Logic Arrays (PLAs) that perform some operations, which have already been known or will be developed in the future.

According to various embodiments, at least a part of the device (e.g., modules or their functions) or method (e.g., operations) may be implemented as instructions stored in a computer-readable storage medium e.g., in the form of a program module. The instructions, when executed by a processor (e.g., the processor **120**), may enable the processor

to carry out a corresponding function. The computer-readable storage medium may be e.g., the memory 130.

The computer-readable storage medium may include a hardware device, such as hard discs, floppy discs, and magnetic tapes (e.g., a magnetic tape), optical media such as compact disc ROMs (CD-ROMs) and digital versatile discs (DVDs), magneto-optical media such as floptical disks, ROMs, RAMs, flash memories, and/or the like. Examples of the program instructions may include not only machine language codes but also high-level language codes which are executable by various computing means using an interpreter. The aforementioned hardware devices may be configured to operate as one or more software modules to carry out various embodiments, and vice versa.

Modules or programming modules in accordance with various embodiments may include at least one or more of the aforementioned components, omit some of them, or further include other additional components. Operations performed by modules, programming modules or other components in accordance with various embodiments may be carried out sequentially, simultaneously, repeatedly, or heuristically. Furthermore, some of the operations may be performed in a different order, or omitted, or include other additional operation(s).

According to various embodiments, there is provided a storage medium storing commands configured to, when executed by at least one processor, enable the at least one processor to perform at least one operation that may include obtaining an image, integrating recognition information about the image with information related to the image, and storing the integrated information as metadata of the image or providing a service or a function using the integrated information.

The embodiments disclosed herein are proposed for description and understanding of the disclosed technology and does not limit the scope of the present disclosure. Accordingly, the scope of the present disclosure should be interpreted as including all changes or various embodiments based on the technical spirit of the present disclosure.

The invention claimed is:

1. A method of an electronic device, the method comprising:

based at least on a user touch input received through a touch screen of the electronic device, obtaining an image from a camera of the electronic device, wherein the image includes at least one object;

obtaining, by the electronic device, information of the image obtained from the camera of the electronic device;

based on the obtaining of the image from the camera, analyzing, by the electronic device, at least a portion of an object included in the image;

obtaining, by the electronic device, at least one metadata of at least one category, respectively, among a plurality of categories based on at least on the analyzing of the at least a portion of the object included in the image;

in response to the obtained at least one metadata not including metadata of one category, obtaining, by the electronic device, the metadata of one category based on a database, wherein the database stores a plurality of metadata of each of the plurality of the categories and a number of images related to at least part of the plurality of the metadata;

receiving a search text which is input, through the touch screen of the electronic device, by a user of the electronic device;

displaying, on the touch screen of the electronic device, a plurality of recommended search texts including one or more recommended search texts being based on at least one of the obtained information of the image or the analyzing of the at least a portion of the object included in the image, wherein a recommended search text from the plurality of recommended search texts is associated with the received search text and includes text associated with a time when the image is obtained or text associated with the object, and wherein another recommended search text from the plurality of recommended search texts corresponds to the obtained at least one metadata and the obtained metadata;

receiving a user selection for one of the plurality of recommended search texts displayed on the touch screen of the electronic device; and

displaying the image on the touch screen of the electronic device based at least on the one of the plurality of recommended search texts.

2. The method of claim 1, wherein the obtained information of the image comprises at least one of time information or location information.

3. The method of claim 1, wherein the object comprises at least one of a recognized person, a recognized thing, or a text in the image.

4. The method of claim 1, wherein the at least one category comprises at least one of a figure category, a location category, or a time category.

5. The method of claim 1, wherein the obtaining the at least one metadata of the at least one category comprises obtaining metadata of a figure category based at least on a recognized person in the image.

6. The method of claim 1, further comprising: displaying a number of images, included in a category from the at least one category, together with the category.

7. The method of claim 1, further comprising: updating the database based on the obtained metadata.

8. An electronic device comprising:

a touch screen;

at least one processor; and

a memory configured to store instructions which, when executed by the at least one processor, cause the at least one processor to perform operations comprising:

based at least on a user touch input received through the touch screen of the electronic device, obtaining an image from a camera of the electronic device, wherein the image includes at least one object,

obtaining information of the image obtained from the camera of the electronic device,

based on the obtaining of the image from the camera, analyzing at least a portion of an object included in the image,

obtaining at least one metadata of at least one category, respectively, among a plurality of categories based on at least on the analyzing of the at least a portion of the object included in the image,

in response to the obtained at least one metadata not including metadata of one category, obtaining the metadata of one category based on a database, wherein the database stores a plurality of metadata of each of the plurality of the categories and a number of images related to at least part of the plurality of the metadata,

receiving a search text which is input, through the touch screen of the electronic device, by a user of the electronic device,

displaying, on the touch screen of the electronic device, a plurality of recommended search texts including one or more recommended search texts being based on at least one of the obtained information of the image or the analyzing of the at least a portion of the object included in the image, wherein a recommended search text from the plurality of recommended search texts is associated with the received search text and includes text associated with a time when the image is obtained or text associated with the object, and wherein another recommended search text from the plurality of recommended search texts corresponds to the obtained at least one metadata and the obtained metadata,

receiving a user selection for one of the plurality of recommended search texts displayed on the touch screen of the electronic device, and

displaying the image on the touch screen of the electronic device based at least on the one of the plurality of recommended search texts.

9. The electronic device of claim 8, wherein the obtained information of the image comprises at least one of time information or location information.

10. The electronic device of claim 8, wherein the object comprises at least one of a recognized person, a recognized thing, or a text in the image.

11. The electronic device of claim 8, wherein the at least one category comprises at least one of a figure category, a location category, or a time category.

12. The electronic device of claim 8, wherein the obtaining the at least one metadata of the at least one category comprises obtaining metadata of a figure category based at least on a recognized person in the image.

13. The electronic device of claim 8, wherein the operations further comprise displaying a number of images, included in a category from the at least one category, together with the category.

14. The electronic device of claim 8, wherein the operations further comprise updating the database based on the obtained metadata.

15. A non-transitory storage medium having stored therein instructions which cause, when executed by at least one processor of an electronic device, the at least one processor to perform operations comprising:

based at least on a user touch input received through a touch screen of the electronic device, obtaining an image from a camera of the electronic device, wherein the image includes at least one object;

obtaining, by the electronic device, information of the image obtained from the camera of the electronic device;

based on the obtaining of the image from the camera, analyzing, by the electronic device, at least a portion of an object included in the image;

obtaining at least one metadata of at least one category, respectively, among a plurality of categories based on at least on the analyzing of the at least a portion of the object included in the image;

in response to the obtained at least one metadata not including metadata of one category; obtaining the metadata of one category based on a database, wherein the database stores a plurality of metadata of each of the plurality of the categories and a number of images related to at least part of the plurality of the metadata; receiving a search text which is input, through the touch screen of the electronic device, by a user of the electronic device;

displaying, on the touch screen of the electronic device, a plurality of recommended search texts including one or more recommended search texts being based on at least one of the obtained information of the image or the analyzing of the at least a portion of the object included in the image, wherein a recommended search text from the plurality of recommended search texts is associated with the received search text and includes text associated with a time when the image is obtained or text associated with the object, and wherein another recommended search text from the plurality of recommended search texts corresponds to the obtained at least one metadata and the obtained metadata;

receiving a user selection for one of the plurality of recommended search texts displayed on the touch screen of the electronic device; and

displaying the image on the touch screen of the electronic device based at least on the one of the plurality of recommended search texts.

16. The non-transitory storage medium of claim 15, wherein the obtained information of the image comprises at least one of time information or location information.

17. The non-transitory storage medium of claim 15, wherein the object comprises at least one of a recognized person, a recognized thing, or a text in the image.

18. The non-transitory storage medium of claim 15, wherein the at least one category comprises at least one of a figure category, a location category, or a time category.

19. The non-transitory storage medium of claim 15, wherein the obtaining the at least one metadata of the at least one category comprises obtaining metadata of a figure category based at least on a recognized person in the image.

20. The non-transitory storage medium of claim 15, wherein the operations further comprise displaying a number of images, included in a category from the at least one category, together with the category.

* * * * *