



- (51) International Patent Classification:  
A61F 2/16 (2006.01)
- (21) International Application Number:  
PCT/US2013/061452
- (22) International Filing Date:  
24 September 2013 (24.09.2013)
- (25) Filing Language: English
- (26) Publication Language: English
- (72) Inventor; and
- (71) Applicant : CUMMING, James, Stuart [US/US]; 1219 Emerald Bay, Laguna Beach, CA 92651 (US).
- (74) Agent: ALTMAN, Daniel, E.; Knobbe Martens Olson & Bear, LLP, 2040 Main Street, 14th Floor, Irvine, CA 92614 (US).
- (81) Designated States (unless otherwise indicated, for every kind of national protection available): AE, AG, AL, AM, AO, AT, AU, AZ, BA, BB, BG, BH, BR, BW, BY, BZ, CA, CH, CL, CN, CO, CR, CU, CZ, DE, DK, DM,

DO, DZ, EC, EE, EG, ES, FI, GB, GD, GE, GH, GM, GT, HN, HR, HU, ID, IL, IN, IS, JP, KE, KG, KN, KP, KR, KZ, LA, LC, LK, LR, LS, LT, LU, LY, MA, MD, ME, MG, MK, MN, MW, MX, MY, MZ, NA, NG, NI, NO, NZ, OM, PA, PE, PG, PH, PL, PT, QA, RO, RS, RU, RW, SA, SC, SD, SE, SG, SK, SL, SM, ST, SV, SY, TH, TJ, TM, TN, TR, TT, TZ, UA, UG, US, UZ, VC, VN, ZA, ZM, ZW.

- (84) Designated States (unless otherwise indicated, for every kind of regional protection available): ARIPO (BW, GH, GM, KE, LR, LS, MW, MZ, NA, RW, SD, SL, SZ, TZ, UG, ZM, ZW), Eurasian (AM, AZ, BY, KG, KZ, RU, TJ, TM), European (AL, AT, BE, BG, CH, CY, CZ, DE, DK, EE, ES, FI, FR, GB, GR, HR, HU, IE, IS, IT, LT, LU, LV, MC, MK, MT, NL, NO, PL, PT, RO, RS, SE, SI, SK, SM, TR), OAPI (BF, BJ, CF, CG, CI, CM, GA, GN, GQ, GW, KM, ML, MR, NE, SN, TD, TG).

Published:  
— with international search report (Art. 21(3))

(54) Title: ACCOMMODATING INTRAOCULAR LENS

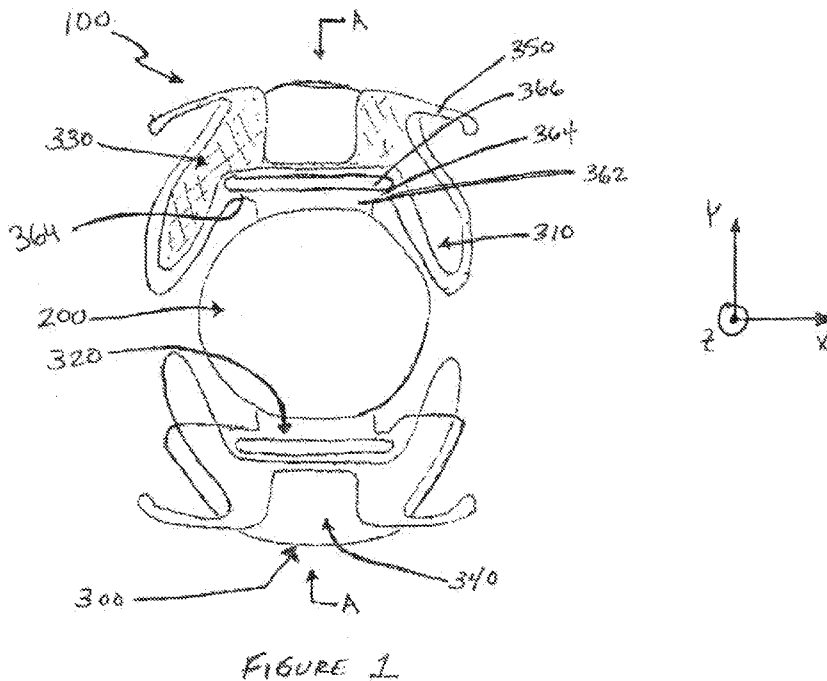

(57) Abstract: An accommodating intraocular lens comprising a lens optic coupled to at least one haptic and at least one deformable connecting bar positioned between the lens optic and the at least one haptic such that the connecting bar facilitates accommodation by deforming in response to a vitreous pressure change.

WO 2015/047227 A1

## ACCOMMODATING INTRAOCULAR LENS

[0001] This application is a continuation in part of U.S. Patent Application No. 13/910,076 titled Torsion Bar Accommodating Intraocular Lens which claim priority to U.S. Provisional Application No. 61/689,394, filed on June 5, 2012. The contents and disclosures of each of these applications are fully incorporated herein by reference. This application also incorporated by reference the contents and disclosure of the following: U.S. Publication No. 20110313519, filed January 31, 2011; U.S. Publication No. 2011/0313524, filed April 22, 2011; U.S. Publication No. 2011/0313525, filed May 19, 2011; U.S. Publication No. 2011/0313526, filed June 7, 2011; U.S. Patent No. 8,523,942, filed May 15, 2012; U.S. Publication No. 2012/0310344, filed May 16, 2012; U.S. Application Serial No. 13/891,088, filed May 9, 2013; and U.S. Application Serial No. 13/910,076, filed June 4, 2013.

## BACKGROUND

### Field

[0002] The present disclosure is related to a single focus accommodating intraocular lens, various embodiments of which provide seamless vision from distance to near automatically by relaxation and constriction of ciliary muscle.

### Description of the Related Art

[0003] An intraocular lens (IOL) is a lens implanted into the eye, usually replacing a normal human lens that has been clouded over by a cataract, or can replace a normal human lens as a form of refractive surgery to change the eye's optical power.

[0004] Premium intraocular lenses (IOLs) implanted during cataract surgery are categorized three ways: accommodating, multifocal, and toric intraocular lenses.

[0005] The best visual acuity is achieved with the single focus accommodating lenses. The optic of these lenses moves forward and backward upon constriction and relaxation of the ciliary

muscle. However, for reading in dim lighting conditions, or for small print, weak reading glasses are often necessary.

[0006] The multifocal lenses focus light on the retina at either two or three focal lengths. Thus, there is more than one image on the retina simultaneously. This creates problems since the amount of light in focus is divided between the multiple focal points, and contrast sensitivity is thereby reduced, making vision at all distances difficult in dim lighting. In addition, there are severe problems when driving at night when the pupil is dilated. Many patients experience severe glare and halos and many have had to have the multifocal lenses explanted and replaced with a single vision standard lens, because of this problem. However, the near vision with the multifocal lenses is superior to that of the current accommodating lens.

[0007] The toric lenses correct the eyes that have significant astigmatism.

[0008] The currently marketed plate accommodating intraocular lenses provide excellent distance and intermediate vision but sometimes can require weak, +1.00, reading glasses for prolonged reading, for seeing small print, or reading in dim lighting conditions.

[0009] Furthermore, it is important for intraocular lenses to have a consistent location along the axis of the eye to provide good uncorrected distance vision and to center in the middle of the vertical meridian of the eye. Without excellent uncorrected distance vision there is no point in implanting lenses designed to give seamless vision from far to near.

[0010] The original intraocular lens consisted of a single optic. These lenses frequently de-centered and dislocated and it was discovered that there was a need to center and fixate the lens optic in the vertical meridian of the eye.

[0011] Attachments to the optic that center and fixate the lens within the capsular bag are called haptics. Traditionally, haptics comprise multiple flexible loops of various designs, J loops, C loops, closed loops, and flexible radial arms. Recently, traditional haptics have been replaced in some lens designs with oblong, flat flexible plates, called plate haptics. These plate

haptics usually made from silicone, are solid, flat, flexible and between 3.0 and 6.0 mm in width, 0.20 to 0.75 mm thick, and may have tapered, rounded or parallel sides. Plate haptics often have flexible loops or fingers that help center and fixate the lens within the capsular bag. These flexible fingers extend beyond the distal or outer end of the plate haptics and slightly beyond the diameter of the capsular bag and are designed to flex centrally to center and fixate the lens and its optic within the capsular bag.

[0012] An accommodating IOL (AIOL) permits refocusing of the eye by means of movement along the optical axis in response to the constriction or relaxation of ciliary muscles. Near vision results from a forward movement of the optic upon constriction of the ciliary muscle which increases the pressure in the posterior part of the eye with a simultaneous decrease in pressure in the anterior part of the eye. Distance vision results from the reverse pressure change that takes place upon relaxation of the ciliary muscle and the resultant backwards movement of the lens. The movement of the optic enables the patient implanted with the lens to automatically change their vision between far, intermediate and near.

[0013] AIOLs are known to include opposing haptics positioned on either side of a lens optic. Once a patient's cataract is removed, e.g. by phacoemulsification, the AIOL is placed into the empty capsular bag. The haptics help to center the AIOL and fixate it within the capsular bag by fibrosis. Such AIOLs are described in U.S. Patent No. 5,674,282, U.S. Patent No. 5,476,514, and U.S. Patent No. 5,496,366, to Cumming, herein incorporated by reference in its entirety.

[0014] Moreover, although current AIOLs provide patients with significantly restored distance and intermediate vision, adequate near vision is commonly lacking – often requiring that patients use weak reading glasses to enhance near vision.

## SUMMARY

[0015] An accommodating intraocular lens according to an embodiment of the present disclosure is described that overcomes the deficiencies of present designs noted above.

[0016] In various embodiments, an accommodating intraocular lens comprises a lens optic coupled to at least one haptic and a torsion bar positioned between the lens optic and the at least one haptic such that the torsion bar facilitates accommodation by deforming in response to a vitreous pressure change.

[0017] The connecting portion unlike a flat hinge flexing mechanism or a flat thin stretching hinge may have a cross section that can be round, oval, square or any variation of these. The connecting portion can have a length of between about 0.1 to 1.5 mm, in various embodiments between about 0.5 and 1.0 mm, or between about 0.1 mm to 1.0 mm. The connecting portion can connect tangentially to the optic in a transverse direction across the lens body, or connect in a radial or perpendicular manner, to function by stretching, thinning, rotating, or any combination of these.

[0018] Certain aspects of this disclosure are directed toward an accommodating intraocular lens. The intraocular lens can include a lens optic having a diameter, at least one haptic coupled to the lens optic, and at least one connecting bar connecting the lens optic and the at least one haptic. The connecting bar can facilitate accommodation by deforming in response to a vitreous pressure change. The connecting bar can have a width and thickness less than 30% the diameter of the optic.

[0019] Certain aspects of this disclosure are directed toward an accommodating intraocular lens having a lens optic coupled to at least one haptic. The at least one haptic can be primarily disposed on opposite first and second sides of the lens optic. The first side, the lens optic, and the second side can be arranged along a longitudinal axis of the accommodating intraocular lens. The at least one connecting bar can connect the lens optic and the at least one haptic. The at least one connecting bar can have a length disposed substantially orthogonal to said longitudinal axis of said accommodating intraocular lens.

[0020] Certain aspects of this disclosure are directed toward an accommodating intraocular lens having a lens optic coupled to at least one haptic. The at least one haptic can be primarily disposed on opposite first and second sides of the lens optic. The first side, the lens optic, and

the second side can be arranged along a longitudinal axis of the accommodating intraocular lens. The at least one connecting bar can connect the lens optic and the at least one haptic. The at least one connecting bar can have a length disposed substantially parallel to said longitudinal axis of said accommodating intraocular lens.

[0021] Certain aspects of this disclosure are directed toward an accommodating intraocular lens having a lens optic coupled to at least one haptic. The at least one haptic can be primarily disposed on opposite first and second sides of the lens optic. The first side, the lens optic, and the second side can be arranged along a longitudinal axis of the accommodating intraocular lens. The at least one connecting bar can connect the lens optic and the at least one haptic. The at least one connecting bar can have a length disposed at an angle within about 30 degrees (e.g., within about 10 degrees, about 15 degrees, within about 20 degrees, or about 25 degrees) from said longitudinal axis of said accommodating intraocular lens.

[0022] Certain aspects of this disclosure are directed toward an accommodating intraocular lens having a lens optic coupled to at least one haptic. The at least one haptic can be primarily disposed on opposite first and second sides of the lens optic. The first side, the lens optic, and the second side can be arranged along a longitudinal axis of the accommodating intraocular lens. The at least one connecting bar can connect the lens optic and the at least one haptic. The at least one connecting bar can have a length disposed at an angle within about 30 degrees (e.g., at least about 10 degrees, about 15 degrees, about 20 degrees, or about 25 degrees) from an axis orthogonal to said longitudinal axis of said accommodating intraocular lens (i.e., a transverse axis of said accommodating intraocular lens).

[0023] In any of the above mentioned aspects, the intraocular lens may further include an optic appendage attached to said lens optic. The connecting bar can connect the optic appendage and the at least one haptic. In other aspects, the connecting bar directly connects the optic to the at least one haptic.

[0024] In any of the above mentioned aspects, the connecting bar can have a length between about 0.1 and 2.0 mm.

[0025] In any of the above mentioned aspects, the connecting bar can have a circular cross-section orthogonal to the length of the bar. In other aspects, the connecting bar can have an ovalular cross section orthogonal to the length of the bar. In yet other aspects, the connecting bar can have a square cross-section orthogonal to the length of the bar.

[0026] In any of the above mentioned aspects, the connecting bar can be configured to elongate when subjected to pressure changes. In certain aspects, the connecting bar can be configured to thin when subjected to pressure changes. In certain aspects, the connecting bar can be configured to rotate when subjected to pressure changes.

[0027] In any of the above mentioned aspects, the connecting bar can include the same material as the haptic. In other aspects, the connecting bar includes a different material than the haptic.

[0028] In any of the above mentioned aspects, the intraocular lens can include an elongate slot partially traversing the haptic in the transverse direction of said intraocular lens. In certain aspects, the slot can be between 0.1 to 0.5 mm in height and 2 to 5 mm in length. In certain aspects, the connecting bar can be configured to permit forward movement of the lens optic by stretching more than bending in response posterior pressure comparable to the vitreous pressure of an accommodating eye.

[0029] In any of the above mentioned aspects, the intraocular lens may not include a hinging feature between the lens optic and the haptic.

[0030] Other features and advantages of the present disclosure will become apparent from the following more detailed description, taken in conjunction with the accompanying drawings, which illustrate, by way of example, the principles of the presently described apparatus and method of its use.

## BRIEF DESCRIPTION OF THE SEVERAL VIEWS OF THE DRAWING(S)

[0031] Figure 1 illustrates a top plan view of an AIOL according to at least one embodiment of the present disclosure with transversely directed torsion bars connecting the optic to the haptics.

[0032] Figure 2 illustrates a portion of an AIOL according to another embodiment of the present disclosure with generally longitudinally directed connector bars connecting the optic to the haptics.

## DETAILED DESCRIPTION

[0033] The above-described drawing figures illustrate the described disclosure in at least one of its preferred embodiments, which is further defined in detail in the following description. Those having ordinary skill in the art may be able to make alterations and modifications to what is described herein without departing from its spirit and scope. Therefore, it should be understood that what is illustrated is set forth only for the purposes of example and should not be taken as a limitation on the scope of the present disclosure.

[0034] FIG. 1 illustrates accommodating intraocular lens (AIOL) **100** comprising an optic **200** a short appendage **362** attached to the optic and coupled to at least one haptic **300** as well as connection bars **364** connecting the optic to the at least one haptic via the appendage **362**.

[0035] The AIOL **100** is placed into the capsular bag of a patient's eye during cataract surgery involving known techniques such as, for example, phacoemulsification. The lens is centered so that the optical axis of the lens coincides with that of the patient's eye. The haptics **300** contact the capsular bag and the natural fibrosis of the tissue secures the haptics **300**, and consequently the AIOL **100**, in place.

[0036] The optic **200** is preferably a single focus optic that gathers the incoming light and focuses it on the retina of the patient to affect vision. The optic **200** may be biconvex, refractive,



diffractive, plano-convex, Fresnel, spheric, aspheric, toric, or of any other type that is preferably substantially single focus. In order to permit the optic **200** to be inserted into the eye through a small incision, the optic **200** is preferably made of a flexible optical material, such as, for example, silicone, acrylic, hydrogel, or other flexible optical material now known or hereafter developed.

[0037] The at least one haptic **300** comprises a first end **320** opposite a second end **340**. The first end **320** of the haptic **300** can be proximal the optic **200** while the second end is distal to the optic. The first end **320** is flexibly coupled to a periphery of the optic **200** or short appendage **362**. In at least one embodiment, the AIOL **100** comprises opposing haptics positioned linearly along a longitudinal axis **A** of the AIOL **100** (e.g., parallel to the y-axis).

[0038] The haptic body may be substantially flexible in the transverse direction (e.g., parallel to the x-axis) and substantially rigid in the longitudinal direction (e.g., parallel to the y-axis) to enable the AIOL **100** to be folded and inserted into the eye via a small incision. While the plate haptic is substantially rigid, the flexibility of the connecting bar may promote vaulting. In various embodiments, the haptic **300** is constructed of the same or similar flexible material as the optic, including, but not limited to: silicone, hydrogel, acrylic, or similar material.

[0039] The plate haptic **300** may comprise opposing lateral paddles **310**. The paddles **310** and projecting fingers **350** operable to engage, fixate, and center the AIOL in the capsular bag. In certain aspects, the paddles **310** can include a different, more rigid material than the plate haptics **300**. For example, the paddles **310** can be made of polyimide, prolene, or titanium. The paddles may be useful for dipping into the vitreous cavity to further increase the pressure. The paddles also help stabilize the lens to prevent the AIOL from tilting. The paddles can also prevent anterior dislocation of one of the two plate haptics. Such exemplary haptics **300** and paddles **310** are discussed in U.S. Patent Publication 2011-0313519 A1, published December 22, 2011 (U.S. Patent Nos. 13/017,189); U.S. Patent Publication 2011-0313524 A1, published December 22, 2011 (U.S. Patent Nos. 13/092,359); U.S. Patent Publication 2011-0313525 A1, published December 22, 2011 (U.S. Patent Nos. 13/111,599); and U.S. Patent Publication

2011-0313526 A1, published December 22, 2011 (U.S. Patent Nos. 13/155,327), incorporated herein by reference in their entireties.

[0040] The paddles **310** and/or the plate haptics **300** together can surround at least a portion of the optic or surround a majority of the optic. The paddles **310** and/or the plate haptics **300** together can surround between about 100 to 350 degrees of the optic, for example, between about 100 and 200 degrees, between about 150 degrees and 250 degrees, between about 200 degrees and about 300 degrees, or between about 250 degrees and 350 degrees. The paddles **310** together extend along the sides of the optic and more particularly about 50%, 60%, 70%, 80% or more of the length of the optic. In various embodiments, the paddles **310** extend along the optic **200** in the lateral direction (parallel to the x-axis) at least about 10% the diameter of the optic. In certain aspects, the paddles can include curved edges, for example, as shown in the figures, the paddles can curve inward to at least partially conform to the shape of the optic. In certain aspects, a length of the paddle can be at least two times, at least three times, or at least four times longer than a width of the paddle. In certain aspects, an end of the paddle closest to the optic can be tapered.

[0041] A frame **330** may be embedded within the haptic **300**. The frame **330** may be formed of polyimide, prolene, polymethylmethacrylate (PMMA), titanium, or similar material. The frame **330** may be a meshwork or lattice, designed and shaped in a manner to make the plate haptics rigid longitudinally but flexible transversely. Such exemplary frames **330** are discussed in U.S. Patent Publication 2011-0313519 A1, published December 22, 2011 (U.S. Patent Nos. 13/017,189); U.S. Patent Publication 2011-0313524 A1, published December 22, 2011 (U.S. Patent Nos. 13/092,359); U.S. Patent Publication 2011-0313525 A1, published December 22, 2011 (U.S. Patent Nos. 13/111,599); and U.S. Patent Publication 2011-0313526 A1, published December 22, 2011 (U.S. Patent Nos. 13/155,327), incorporated herein by reference in their entireties.

[0042] The haptic **300** may further comprise projections **350**, or fingers, extending from the second end (distal to the optic **200**) to engage the capsular bag and secure and center the AIOL thereto. The projections **350** may be homogeneous with the frame and may be made of either

polyimide, PMMA, acrylic or any other inert material. Such exemplary projections **350** are discussed in U.S. Patent Publication 2011-0313519 A1, published December 22, 2011 (U.S. Patent Nos. 13/017,189); U.S. Patent Publication 2011-0313524 A1, published December 22, 2011 (U.S. Patent Nos. 13/092,359); U.S. Patent Publication 2011-0313525 A1, published December 22, 2011 (U.S. Patent Nos. 13/111,599); and U.S. Patent Publication 2011-0313526 A1, published December 22, 2011 (U.S. Patent Nos. 13/155,327), incorporated herein by reference in their entireties.

[0043] The first end **320** of the haptic **300** (e.g., proximal to the optic **200**) may be coupled to the optic or short appendage of the optic **362** via one or more connecting portions. The connecting bars **364** may operate to permit contraction of the ciliary muscles to cause an end-to-end compression of opposing haptics with an increase in vitreous pressure, with resultant movement of the optic being substantially forward. The connecting portions, bars, or members, **364** shown in FIG. 1 are capable of stretching, bending, and/or potentially rotating when subjected to posterior pressure. Depending on the configuration of the connecting portions **364**, the connecting portions **364** may stretch along the length thereof, which may be at least in part along a direction substantially parallel to the longitudinal axis of the AIOL and/or may be at least partly along an axis that is substantially perpendicular to the longitudinal axis of the AIOL or along the transverse direction (e.g., parallel to x-axis and/or z-axis). Further, the connecting portions **364** may twist or rotate about an axis along the length of the connecting portion, which may be about an axis that is substantially perpendicular to the longitudinal axis of the AIOL (e.g. about an axis parallel to z-axis and/or x-axis) and/or may be about an axis that is substantially parallel to the longitudinal axis of the AIOL (e.g. about an axis parallel to y-axis) in some cases. In some embodiments, each of the connecting portions **364** can be positioned adjacent the optic periphery and flexibly coupled thereto. The connecting portions **364** can be oriented such that their length extends along an axis substantially parallel to a transverse axis of the AIOL **100** (e.g. along an axis parallel to the x-axis) as shown in FIG. 1 or substantially parallel to a longitudinal axis of the AIOL **100** as shown in FIG. 2.

[0044] With continued reference to Figure 1, as disclosed above, one or more connecting portions **364** can be oriented along an axis substantially parallel to a transverse axis of the AIOL

**100** (e.g. parallel to the x-axis). The AIOL **100** can include two connecting portions **364** for securing each haptic **300** to the short appendage **362** and optic **200**. The connecting portions **364** can connect the haptic **300** to the short appendage **362** such that an elongate slot **366** is formed between the short appendage **362** and the haptic **300**. An elongate axis of the elongate slot **366** can be substantially perpendicular to the longitudinal axis of the AIOL through line A-A (e.g. perpendicular to the y-axis) in some embodiments. Although not shown, the connecting portions **364** may be oriented along an axis that is less than or equal to about 5°, 10°, 15°, 20°, 25°, 30°, 35°, 40°, or 45° from the transverse axis of the AIOL (e.g., axis parallel to x-axis).

[0045] The elongate slot **366** is an aperture formed in the haptic **300** that extends laterally and parallel to the transverse direction (e.g. parallel to the x-axis). Preferably, the slot **366** comprises an oval shape, but all shapes are specifically contemplated. As mentioned above, the slot **366** is adjacent the connecting portions distal to the optic **200**. Preferably, the slot dimensions ranging from 0.1 to 0.5 mm in height and 2.0 to 5.0 mm in length.

[0046] As shown in Figure 2, one or more connecting portions or connecting bar **364** can be oriented or extend along an axis that is substantially parallel to a longitudinal axis of the AIOL **100** (e.g. along an axis parallel to the y-axis). In some embodiments, the AIOL **100** can include two connecting portions or bars **364** for securing each haptic **300** to the optic **200** although more or less are possible. For example, although not shown, each haptic **300** can be connected to the optic **200** by a single connecting portion **364**. Reducing the number of connecting portion **364** can be beneficial to decrease the force necessary to move the optic relative to the haptics. Although not shown, the connecting portions **364** may be oriented along an axis that is less than or equal to about 5°, 10°, 15°, 20°, 25°, 30°, 35°, 40°, or 45° from the longitudinal axis of the AIOL (e.g., axis parallel to y-axis).

[0047] The connecting portions **364** can connect the haptic **300** to the optic **200** such that an elongate slot is formed between the optic **200** and the haptic **300**. An elongate axis of the elongate slot can be substantially perpendicular to the longitudinal axis of the AIOL through line A-A (e.g. parallel to the x-axis).

[0048] The connecting portions **364** couples the optic **200** to the haptic **300** and is preferably of the same material as the optic. The connecting portions **364** assist in accommodation in that they decrease the resistance to the pressure that pushes the optic forward. In various embodiments, such connecting portions **364** are not hinges in the sense that they primarily stretch and do not bend like a hinge when the optic **200** is vaulted forward because of an increase in vitreous pressure during accommodation. Likewise, in various embodiments, the connecting portions **364** may not include a hinge feature, for example, between the optic **200** or appendage **362** and the haptic **300** about which portions of the connecting portion bend like a hinge. Example hinges or straps with hinge features are described in U.S. Patent Publication 2011-0313519 A1, published December 22, 2011 (U.S. Patent Nos. 13/017,189); U.S. Patent Publication 2011-0313524 A1, published December 22, 2011 (U.S. Patent Nos. 13/092,359); U.S. Patent Publication 2011-0313525 A1, published December 22, 2011 (U.S. Patent Nos. 13/111,599); and U.S. Patent Publication 2011-0313526 A1, published December 22, 2011 (U.S. Patent Nos. 13/155,327), incorporated herein by reference in their entireties.

[0049] The connecting portions or bars **364** can extend lengthwise laterally (as in FIG. 1) or longitudinally (as in FIG. 2) between opposing paddles of the haptic along an axis either substantially parallel or substantially perpendicular to the longitudinal axis of the AIOL through line A-A. Moreover, the connecting portions are in various embodiments integral to the haptic **300** at each of the lateral ends (as shown in FIG. 1) or at each of the end distal to the optic **200** (as shown in FIG. 2), and are preferably of the same flexible material as the haptic. However, the connecting portions **364** may also be of a different material than the haptic **300**, for example, such that the connecting portions are substantially more flexible than the haptic. In at least one embodiment, the connecting portions **364** may be from 0.1 to 1.5 mm in length. Preferably, the connecting portion **364** has a square or circular cross-section, but other cross-sectional solid shapes are specifically contemplated. Accordingly, in various embodiments, the cross-section has a width and height that are substantially equal and may be smaller than the length of the connecting portion or bar **364**. For example, the width of the cross-section perpendicular to the length of the connecting portion or bar **364** may be less than 1.5, 1.4, 1.3, 1.2, or 1.0 times the height of the cross-section or may be smaller and possibly larger in some embodiments. Similarly, the width of the cross-section perpendicular to the length of the connecting portion or

bar **364** may be less than 2.0, 1.5, 1.2, or 1.0 times the length of connecting portion or bar or may be smaller and possibly larger in some embodiments.

[0050] On insertion into the eye, the optic **200** and haptics **300** may be vaulted posteriorly. The haptics may move centrally and posteriorly in response to ciliary muscle contraction, i.e. end-to-end compression. Such movement increases the vitreous pressure, causing the optic to vault forward by stretching and potentially thinning of the connecting portion **364**. This increase in pressure is further facilitated by the paddles dipping posteriorly into the vitreous cavity. This effect is facilitated by the stretching, and potentially thinning, bending, and/or rotation of the connecting portions in response to the increase in pressure. Relaxation of the ciliary muscle increases the diameter of the ciliary muscle and reduces the vitreous cavity pressure with a concomitant increase in pressure in the anterior part of the eye such that the optic **200** moves posteriorly to the distant vision position.

[0051] In at least one embodiment, the longitudinal length of the AIOL (e.g., from distal end to distal end, wherein the distal end is distal with respect to the optic **200**) may be between approximately 9.0-11.0 mm, with the diameter as measured from the tips of the lateral finger projections with respect to the optic being between approximately 11.5-12.0 mm. The haptics **300** are in various embodiments between 3.0-6.0 mm wide and 0.20-0.75 mm thick, while the optic **200** may be approximately 5.0 mm in diameter and 1.0 mm thick at its center.

[0052] In various embodiments the connecting portions or connecting bars **364** are thin and experience more thinning when stretched. Without stretching, for example, the connecting portions or connecting bars **364** may be thin with respect to the optic **200** and the lens **100**. In certain embodiments, for example as shown in Fig. 2, the connecting portion or connecting bar **364** may have a width in the transverse direction (e.g., parallel to the x-axis) less than 50%, 40%, 30%, 20%, 10%, 5% or less of the width or diameter of the optic **200**. Similarly, the connecting portions or connecting bars **364** may have a thickness orthogonal to the transverse and longitudinal directions (e.g., parallel to the z-axis) that is less than 50%, 40%, 30%, 20%, 10%, 5% or less of the diameter of the width or diameter of the optic **200**. The width and thicknesses may be greater than 0.5% or 1% of width or diameter of the optic **200** in some embodiments.

[0053] The dimensions described above allow for adequate stretching. Additionally, such widths may reduce the incidence of tearing when inserting the AIOL into the small opening made in the sclera or cornea of the eye. The AIOL is rolled to facilitate insertion and the resultant twisting can introduce shear forces on wider connections, which may cause tearing. Having narrow widths reduces the shear force and permits twisting without tearing.

[0054] The connecting portions or bars **364** such as shown in FIGS. 1 and 2 being thin permit stretching. In various embodiments, the connecting portions or bars **364** stretch and thereby increase their length by at least 0.5, 1.0, 1.5, or 2.0 times of their length or more. Accordingly, in some embodiments such as the configuration shown in FIG. 2 and possibly the configuration shown in FIG. 1, the connecting portions or bars **364** operate to permit vaulting forward of the optic during accommodation more by stretching than by bending. Likewise, in various embodiments, the connecting portions or bars **364** are configured to primarily stretch rather than bend (e.g., like a hinge) when the lens is exposed to posterior pressure akin to the increase pressure in the posterior part of the eye with an accommodating eye as well as a simultaneous anterior pressure akin to the simultaneous decrease in pressure in the anterior part of the eye during accommodation.

[0055] Conditional language, such as “can,” “could,” “might,” or “may,” unless specifically stated otherwise, or otherwise understood within the context as used, is generally intended to convey that certain embodiments include, while other embodiments do not include, certain features, elements, and/or steps. Thus, such conditional language is not generally intended to imply that features, elements, and/or steps are in any way required for one or more embodiments or that one or more embodiments necessarily include logic for deciding, with or without user input or prompting, whether these features, elements, and/or steps are included or are to be performed in any particular embodiment.

[0056] The terms “approximately,” “about,” and “substantially” as used herein represent an amount close to the stated amount that still performs a desired function or achieves a desired result. For example, the terms “approximately”, “about”, and “substantially” may refer to an

amount that is within less than 10% of, within less than 5% of, within less than 1% of, within less than 0.1% of, and within less than 0.01% of the stated amount.

[0057] Some embodiments have been described in connection with the accompanying drawings. However, it should be understood that the figures are not drawn to scale. Distances, angles, etc. are merely illustrative and do not necessarily bear an exact relationship to actual dimensions and layout of the devices illustrated. Components can be added, removed, and/or rearranged. Further, the disclosure herein of any particular feature, aspect, method, property, characteristic, quality, attribute, element, or the like in connection with various embodiments can be used in all other embodiments set forth herein. Additionally, it will be recognized that any methods described herein may be practiced using any device suitable for performing the recited steps.

[0058] The embodiments described in detail above are considered novel over the prior art of record and are considered critical to the operation of at least one aspect of the invention and to the achievement of the above-described objectives. The words used in this specification to describe the instant embodiments are to be understood not only in the sense of their commonly defined meanings, but to include by special definition in this specification: structure, material, or acts beyond the scope of the commonly defined meanings. Thus if an element can be understood in the context of this specification as including more than one meaning, then its use must be understood as being generic to all possible meanings supported by the specification and by the word or words describing the element.

[0059] The definitions of the words or drawing elements described herein are meant to include not only the combination of elements which are literally set forth, but all equivalent structure, material or acts for performing substantially the same function in substantially the same way to obtain substantially the same result. In this sense, it is therefore contemplated that an equivalent substitution of two or more elements may be made for any one of the elements described and its various embodiments or that a single element may be substituted for two or more elements in a claim.



[0060] Changes from the claimed subject matter as viewed by a person with ordinary skill in the art, now known or later devised, are expressly contemplated as being equivalents within the scope intended and its various embodiments. Therefore, obvious substitutions now or later known to one with ordinary skill in the art are defined to be within the scope of the defined elements. This disclosure is thus meant to be understood to include what is specifically illustrated and described above, what is conceptually equivalent, what can be obviously substituted, and what incorporates the essential ideas.

[0061] The scope of this description is to be interpreted only in conjunction with the appended claims and it is made clear, here, that the named inventor believes that the claimed subject matter is what is intended to be patented.

## CLAIMS

WHAT IS CLAIMED IS:

1. An accommodating intraocular lens comprising:  
a lens optic having a diameter,  
at least one haptic coupled to the lens optic; and  
at least one connecting bar connecting the lens optic and the at least one haptic such that the connecting bar facilitates accommodation by deforming in response to a vitreous pressure change, the connecting bar having a width and thickness less than 30% the diameter of the optic.
2. The accommodating intraocular lens of Claim 1, further comprising an optic appendage attached to said lens optic, the connecting bar connecting the optic appendage and the at least one haptic.
3. The accommodating intraocular lens of Claim 1, wherein the connecting bar directly connects the optic to the at least one haptic.
4. The accommodating intraocular lens of any one of Claims 1-3, wherein the connecting bar has a length between 0.1 and 2.0 mm.
5. The accommodating intraocular lens of any one of Claims 1-4, wherein the connecting bar has a length that is oriented along an axis that is substantially perpendicular to a longitudinal axis of the intraocular lens.
6. The accommodating intraocular lens any one of Claims 1-4, wherein the connecting bar has a length that is oriented along an axis that is substantially parallel to a longitudinal axis of the intraocular lens.
7. The accommodating intraocular lens of any one of Claims 1-6, wherein the connecting bar has a circular cross-section orthogonal to the length of the bar.
8. The accommodating intraocular lens of any one of Claims 1-6, wherein the connecting bar has an ovular cross-section orthogonal to the length of the bar.
9. The accommodating intraocular lens of any one of Claims 1-6, wherein the connecting bar has a square cross-section orthogonal to the length of the bar.
10. The accommodating intraocular lens of any one of Claims 1-9, wherein the connecting bar is configured to elongate when subjected to pressure changes.
11. The accommodating intraocular lens of any one of Claims 1-10, wherein the connecting bar is configured to thin when subjected to pressure changes.

12. The accommodating intraocular lens of any one of Claims 1-11, wherein the connecting bar is configured to rotate when subjected to pressure changes.

13. The accommodating intraocular lens of any one of Claims 1-12, wherein the connecting bar is of the same material as the haptic.

14. The accommodating intraocular lens of any one of Claims 1-12, wherein the connecting bar is of a different material than the haptic.

15. The accommodating intraocular lens of any one of Claims 1-14, wherein intraocular lens includes an elongate slot partially traversing the haptic in the transverse direction of said intraocular lens.

16. The accommodating intraocular lens of any one of Claims 15, wherein slot is between 0.1 to 0.5 mm in height and 2 to 5 mm in length.

17. The accommodating intraocular lens of any one of Claims 15, wherein the connecting bar is configured to permit forward movement of the lens optic by stretching more than bending in response posterior pressure comparable to the vitreous pressure of an accommodating eye.

18. The accommodating intraocular lens of any one of Claims 1-17, wherein intraocular lens does not include a hinging feature between the lens optic and the haptic.

19. An accommodating intraocular lens comprising:

a lens optic coupled to at least one haptic, said at least one haptic primarily disposed on opposite first and second sides of the lens optic, the first side, the lens optic, and the second side arranged along a longitudinal axis of said accommodating intraocular lens; and

at least one connecting bar connecting the lens optic and the at least one haptic, the at least one connecting bar having a length disposed substantially orthogonal to said longitudinal axis of said accommodating intraocular lens.

20. The accommodating intraocular lens of Claim 19, further comprising an optic appendage attached to said lens optic, and wherein the connecting bar connects the optic appendage and the at least one haptic.

21. The accommodating intraocular lens of Claim 19, wherein the connecting bar directly connects the optic to the at least one haptic.

22. The accommodating intraocular lens of any one of Claims 19-21, wherein the length of the connecting bar is between 0.1 and 2.0 mm.

23. The accommodating intraocular lens of any one of Claims 19-22, wherein the connecting bar has a circular cross-section orthogonal to the length of the bar.

24. The accommodating intraocular lens of any one of Claims 19-22, wherein the connecting bar has an ovular cross section orthogonal to the length of the bar.

25. The accommodating intraocular lens of any one of Claims 19-22, wherein the connecting bar has a square cross section orthogonal to the length of the bar.

26. The accommodating intraocular lens of any one of Claims 19-25, wherein the connecting bar is configured to elongate when subjected to pressure changes.

27. The accommodating intraocular lens of any one of Claims 19-26, wherein the connecting bar is configured to thin when subjected to pressure changes.

28. The accommodating intraocular lens of any one of Claims 19-27, wherein the connecting bar is configured to rotate when subjected to pressure changes.

29. The accommodating intraocular lens of any one of Claims 19-28, wherein the connecting bar is of the same material as the haptic.

30. The accommodating intraocular lens of any one of Claims 19-28, wherein the connecting bar is of a different material than the haptic.

31. The accommodating intraocular lens of any one of Claims 19-31, wherein the connecting bar is defined by an elongate slot partially traversing the haptic in a transverse direction orthogonal to the longitudinal direction.

32. The accommodating intraocular lens of any one of Claims 31, wherein the slot is between 0.1 to 0.5 mm in height and 2 to 5 mm in length.

33. The accommodating intraocular lens of any one of Claims 19-32, wherein intraocular lens does not include a hinging feature between the lens optic and the haptic.

34. The accommodating intraocular lens of Claim 20, wherein the connecting bars extends lengthwise longitudinally from a connection to the optic appendage of the intraocular lens to a connection to the haptic.

35. The accommodating intraocular lens of any one of Claims 19-34, wherein the connecting bar is disposed along an axis that is at an angle within about 1 to 10 degrees from an axis orthogonal to said longitudinal axis of said accommodating intraocular lens.

36. An accommodating intraocular lens comprising:

a lens optic coupled to at least one haptic, said at least one haptic primarily disposed on opposite first and second sides of the lens optic, the first side, the lens optic, and the second side arranged along a longitudinal axis of said accommodating intraocular lens; and

at least one connecting bar connecting the lens optic and the at least one haptic, the connecting bar having a length disposed substantially parallel to said longitudinal axis of said accommodating intraocular lens.

37. The accommodating intraocular lens of Claim 36, wherein the at least one connecting bar is disposed at an angle between about 1 to 10 degrees from the longitudinal axis of the accommodating intraocular lens.

38. An accommodating intraocular lens comprising:

a lens optic coupled to at least one haptic, said at least one haptic primarily disposed on opposite first and second sides of the lens optic, the first side, the lens optic, and the second side arranged along a longitudinal axis of said accommodating intraocular lens; and

at least one connecting bar connecting the lens optic and the at least one haptic, the connecting bar having a length disposed at an angle within about 30 degrees from said longitudinal axis of said accommodating intraocular lens.

39. An accommodating intraocular lens comprising:

a lens optic coupled to at least one haptic, said at least one haptic primarily disposed on opposite first and second sides of the lens optic, the first side, the lens optic, and the second side arranged along a longitudinal axis of said accommodating intraocular lens; and

at least one connecting bar connecting the lens optic and the at least one haptic, the connecting bar having a length disposed at an angle within about 30 degrees from an axis orthogonal to said longitudinal axis of said accommodating intraocular lens.

1/1

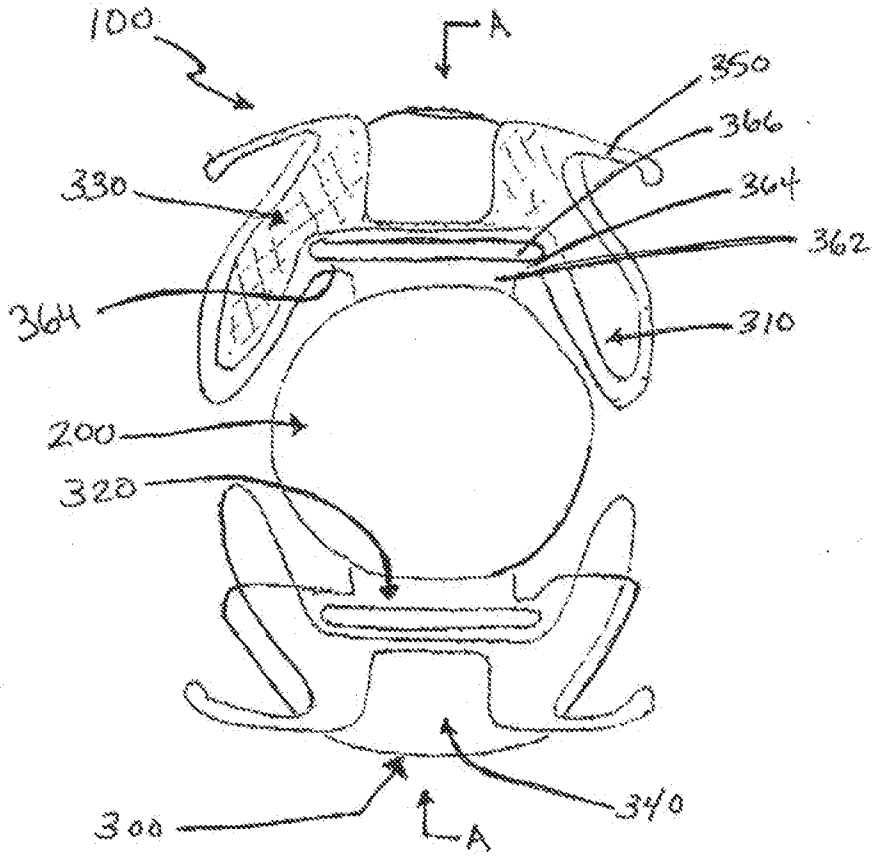

FIGURE 1

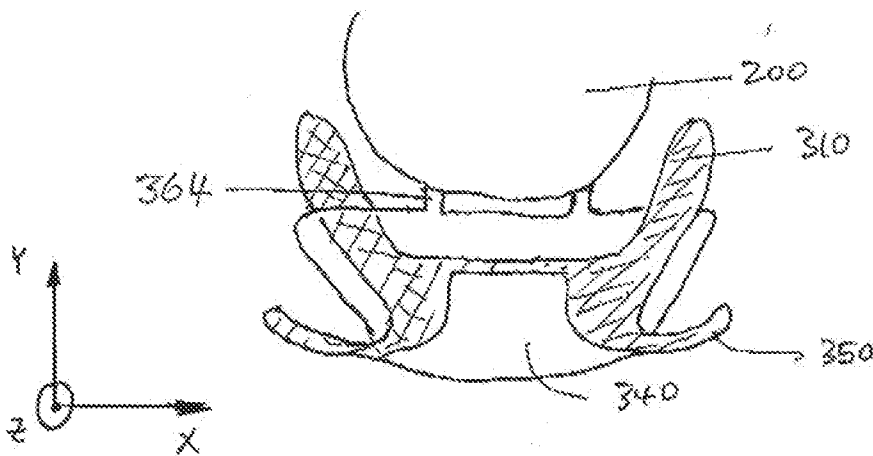

FIG 2.

## INTERNATIONAL SEARCH REPORT

International application No.

PCT/US13/61452

## A. CLASSIFICATION OF SUBJECT MATTER

IPC(8) - A61F 2/16 (2013.01)

USPC - 623/6, 6.37, 6.39, 6.46

According to International Patent Classification (IPC) or to both national classification and IPC

## B. FIELDS SEARCHED

Minimum documentation searched (classification system followed by classification symbols)

IPC(8) - A61F 2/16 (2013.01)

USPC - 623/6, 6.37, 6.39, 6.46

Documentation searched other than minimum documentation to the extent that such documents are included in the fields searched

Electronic data base consulted during the international search (name of data base and, where practicable, search terms used)

MicroPatent (US-G, US-A, EP-A, EP-B, WO, JP-bib, DE-C,B, DE-A, DE-T, DE-U, GB-A, FR-A); Proquest; Google/Google Scholar;  
 Search terms used: Intraocular, lens, lens implant, cataract, lens replacement, light refractor, light transmitter, haptic, side struts, holder, connect\* bar, hitch, link, appendage

## C. DOCUMENTS CONSIDERED TO BE RELEVANT

Category*	Citation of document, with indication, where appropriate, of the relevant passages	Relevant to claim No.
X	US 6197059 B1 (CUMMING, JS) March 6, 2001; abstract; column 7, lines 17-18; column 4, lines 23-24, 30-40; column 11, lines 23-25; column 13, lines 31-40, 56-58; column 25, lines 35-46; column 26, lines 20-21; claim 1-2, 11	1-4
A	US 6387126 B1 (CUMMING, JS) May 14, 2002; abstract; column 1, lines 56-58; column 3, lines 52-56; column 5, lines 38-42; column 9, lines 38-39, 62-67; column 10, lines 1-5, 9-11, column 11, lines 5-6, 10; column 12, lines 39-46; column 13, lines 7-11; column 16, lines 49-53; claims 1-3, 20-21	1-4
A	US 6638306 B2 (CUMMING, JS) October 28, 2003; abstract; column 6, lines 5-10; column 17, lines 28-31; claim 1	1, 3
A	US 5489302 A (SKOTTUN, BC) February 6, 1996; column 2, lines 23-26; claim 4	1, 3
A	US 5843187 A (BAYERS, JH) December 1, 1998; abstract; column 1, lines 34-40; claim 1	1-2

 Further documents are listed in the continuation of Box C.

\* Special categories of cited documents:

"A" document defining the general state of the art which is not considered to be of particular relevance

"E" earlier application or patent but published on or after the international filing date

"L" document which may throw doubts on priority claim(s) or which is cited to establish the publication date of another citation or other special reason (as specified)

"O" document referring to an oral disclosure, use, exhibition or other means

"P" document published prior to the international filing date but later than the priority date claimed

"T" later document published after the international filing date or priority date and not in conflict with the application but cited to understand the principle or theory underlying the invention

"X" document of particular relevance; the claimed invention cannot be considered novel or cannot be considered to involve an inventive step when the document is taken alone

"Y" document of particular relevance; the claimed invention cannot be considered to involve an inventive step when the document is combined with one or more other such documents, such combination being obvious to a person skilled in the art

"&amp;" document member of the same patent family

Date of the actual completion of the international search

10 January 2014 (10.01.2014)

Date of mailing of the international search report

24 FEB 2014

Name and mailing address of the ISA/US

Mail Stop PCT, Attn: ISA/US, Commissioner for Patents  
 P.O. Box 1450, Alexandria, Virginia 22313-1450  
 Facsimile No. 571-273-3201

Authorized officer:

Shane Thomas

PCT Helpdesk: 571-272-4300  
 PCT OSP: 571-272-7774

**Box No. II Observations where certain claims were found unsearchable (Continuation of item 2 of first sheet)**

This international search report has not been established in respect of certain claims under Article 17(2)(a) for the following reasons:

1.  Claims Nos.:  
because they relate to subject matter not required to be searched by this Authority, namely:
  
2.  Claims Nos.:  
because they relate to parts of the international application that do not comply with the prescribed requirements to such an extent that no meaningful international search can be carried out, specifically:
  
3.  Claims Nos.: 5-18, 23-33, 35  
because they are dependent claims and are not drafted in accordance with the second and third sentences of Rule 6.4(a).

**Box No. III Observations where unity of invention is lacking (Continuation of item 3 of first sheet)**

This International Searching Authority found multiple inventions in this international application, as follows:

Group I: Claims 1-4 are directed toward an accommodating intraocular lens comprising: a connecting bar having a width and thickness less than 30% the diameter of the optic.

Group II: Claims 19-22 and 34 are directed toward an accommodating intraocular lens comprising: a connecting bar having a length disposed substantially orthogonal to said longitudinal axis of said accommodating intraocular lens.

Group III: Claims 36-37 are directed toward an accommodating intraocular lens comprising: a connecting bar having a length disposed substantially parallel to said longitudinal axis of said accommodating intraocular lens.

\*\*\*See Supplemental Sheet Below\*\*\*

1.  As all required additional search fees were timely paid by the applicant, this international search report covers all searchable claims.
2.  As all searchable claims could be searched without effort justifying additional fees, this Authority did not invite payment of additional fees.
3.  As only some of the required additional search fees were timely paid by the applicant, this international search report covers only those claims for which fees were paid, specifically claims Nos.:
  
4.  No required additional search fees were timely paid by the applicant. Consequently, this international search report is restricted to the invention first mentioned in the claims; it is covered by claims Nos.:  
1-4

**Remark on Protest**

- The additional search fees were accompanied by the applicant's protest and, where applicable, the payment of a protest fee.
- The additional search fees were accompanied by the applicant's protest but the applicable protest fee was not paid within the time limit specified in the invitation.
- No protest accompanied the payment of additional search fees.



\*\*\*Continuation of Box No. III - Observations where unity of invention is lacking:\*\*\*

Group IV: Claim 38 is directed toward an accommodating intraocular lens comprising: a connecting bar having a length disposed at an angle within about 30 degrees from said longitudinal axis of said accommodating intraocular lens.

Group V: Claim 39 is directed toward an accommodating intraocular lens comprising: a connecting bar having a length disposed at an angle within about 30 degrees from an axis orthogonal to said longitudinal axis of said accommodating intraocular lens.

The inventions listed as Groups I-V do not relate to a single general inventive concept under PCT Rule 13.1 because, under PCT Rule 13.2, they lack the same or corresponding special technical features for the following reasons: the special technical features of Group I include a lens optic having a diameter, such that the connecting bar facilitates accommodation by deforming in response to a vitreous pressure change, the connecting bar having a width and thickness less than 30% the diameter of the optic, which are not present in Groups II-V; the special technical features of Group II include the at least one connecting bar having a length disposed substantially orthogonal to said longitudinal axis of said accommodating intraocular lens, which are not present in Groups I and III-V; the special technical features of Group III include the connecting bar having a length disposed substantially parallel to said longitudinal axis of said accommodating intraocular lens, which are not present in Groups I-II and IV-V; the special technical features of Group IV include the connecting bar having a length disposed at an angle within about 30 degrees from said longitudinal axis of said accommodating intraocular lens, which are not present in Groups I-III and V; the special technical features of Group V include the connecting bar having a length disposed at an angle within about 30 degrees from an axis orthogonal to said longitudinal axis of said accommodating intraocular lens, which are not present in Groups I-IV.

The common technical features of Groups I-V are an accommodating intraocular lens comprising: a lens optic coupled to at least one haptic, and at least one connecting bar connecting the lens optic and the at least one haptic.

These common technical features are disclosed by US 2009/0171458 A1 to Kellan et al. (hereinafter 'Kellan'). Kellan discloses an accommodating intraocular lens (implant 10 can be usefully implanted into the eye as either a refractive phakic intraocular lens assembly or an aphakic intraocular lens assembly; figure 5) comprising: a lens optic coupled to at least one haptic (optic portion 12 is coupled to haptics 20; figure 5), and at least one connecting bar connecting the lens optic and the at least one haptic (anchor portions 16 (connecting bars) couple optic 12 and haptics 20; figure 5).

Since the common technical features are previously disclosed by the Kellan reference, the common features are not special and so Groups I-V lack unity.

The additional common technical features of Groups II-V are said at least one haptic primarily disposed on opposite first and second sides of the lens optic, the first side, the lens optic, and the second side arranged along a longitudinal axis of said accommodating intraocular lens.

These common technical features are disclosed by the Kellan reference. Kellan discloses at least one haptic primarily disposed on opposite first and second sides of the lens optic (haptics 20 are on opposite sides of optic portion 12; figure 5), the first side, the lens optic, and the second side arranged along a longitudinal axis of said accommodating intraocular lens (haptics 20 on either side along with optic portion 12 are all located on the same axis of the implant 10 (intraocular lens); figure 5).

Since the common technical features are previously disclosed by the Kellan reference, the common features are not special and so Groups II-V lack unity.