

- [54] **OPENER AND HOLDER FOR BAGS**
- [76] Inventor: **Herman Wang**, Oscarsgate 74, Oslo, Norway
- [22] Filed: **Nov. 17, 1972**
- [21] Appl. No.: **307,636**
- [30] **Foreign Application Priority Data**  
 Nov. 17, 1971 Norway ..... 4238/71  
 Nov. 2, 1972 Norway ..... 3976/72
- [52] **U.S. Cl.**..... **221/40, 53/384, 93/28, 206/801**
- [51] **Int. Cl.**..... **B65b 43/28**
- [58] **Field of Search** ..... 221/13, 36, 39, 40; 53/189, 384, 386; 93/28-30, 22-24, 15, 16; 214/304; 206/57 A, 494, 801; 229/54 R

- [56] **References Cited**  
**UNITED STATES PATENTS**

3,050,918	8/1962	Helm .....	53/386
3,075,324	1/1963	Burks .....	53/384
3,640,450	2/1972	Lieberman .....	206/57 A
3,707,826	1/1973	Cole .....	53/384
3,789,570	2/1974	Mullins .....	53/189

*Primary Examiner*—Robert B. Reeves  
*Assistant Examiner*—Thomas E. Kocovsky  
*Attorney, Agent, or Firm*—Wenderoth, Lind & Ponack

[57] **ABSTRACT**  
 An apparatus for dispensing and holding carrying bags comprising an apparatus frame, a bag magazine for a supply of individual bags and a carrier means. A bag pick-up and holding means is supported reciprocally on the carrier means in a vicinity directly opposite the magazine rail means, and the pick-up means is operative to move substantially horizontally from an initial position to the foremost bag stored in the magazine and engage particular serrations or cut-outs in the outermost bag panel only. When the carrier means including the pick-up means returns to the initial position a bag is dispensed and held in open position suspended between the magazine rail means and the pick-up means.

**8 Claims, 7 Drawing Figures**

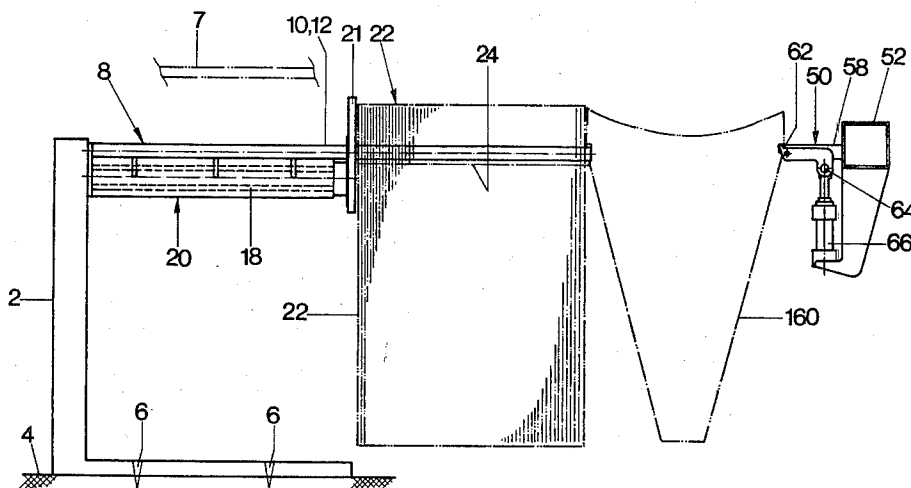



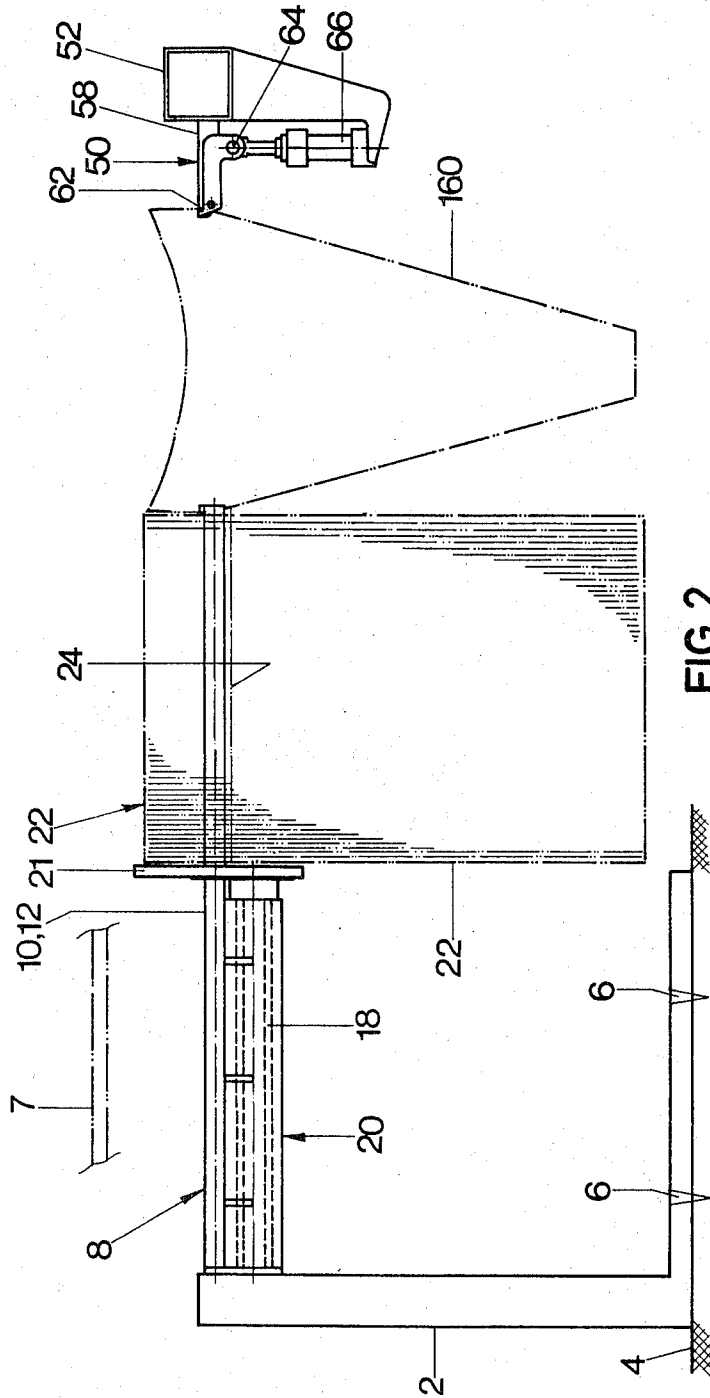
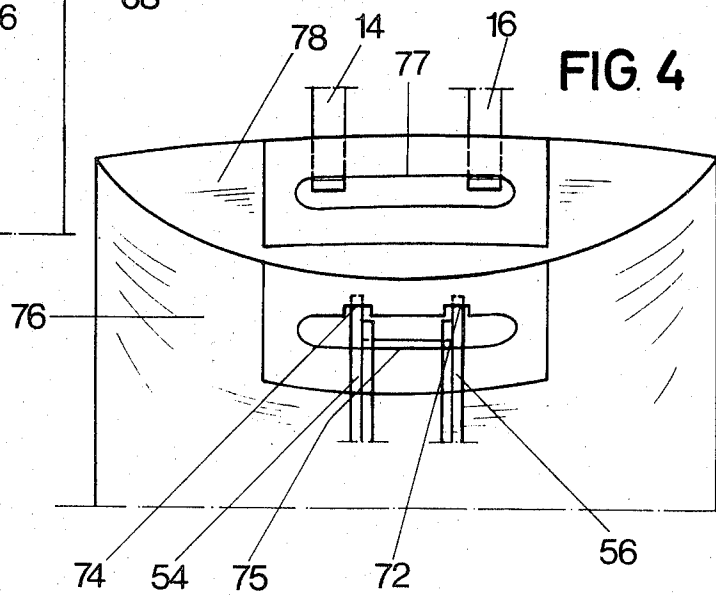
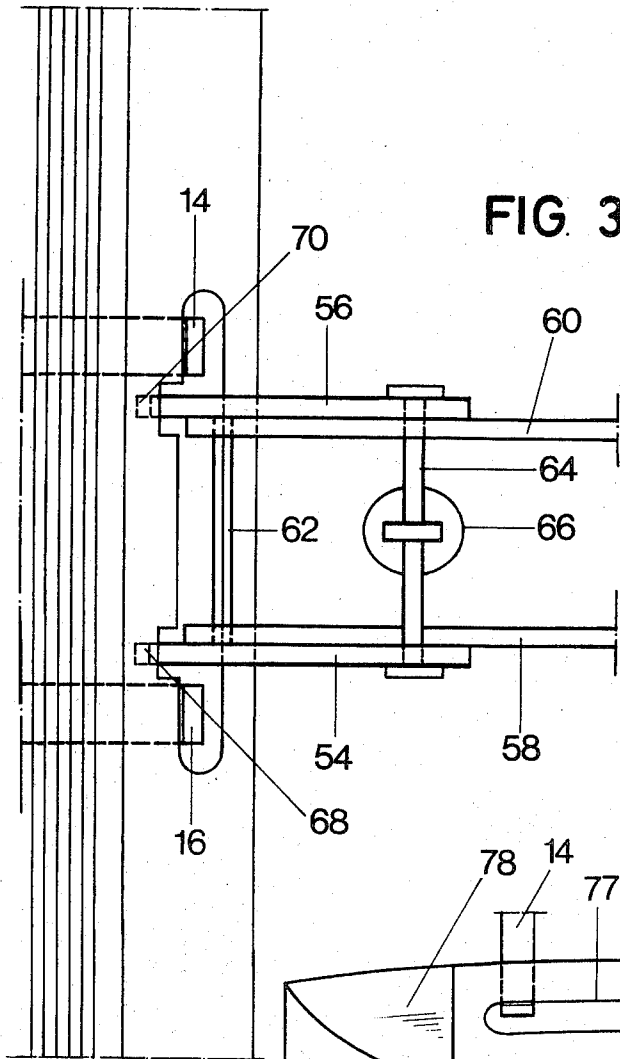

FIG 2



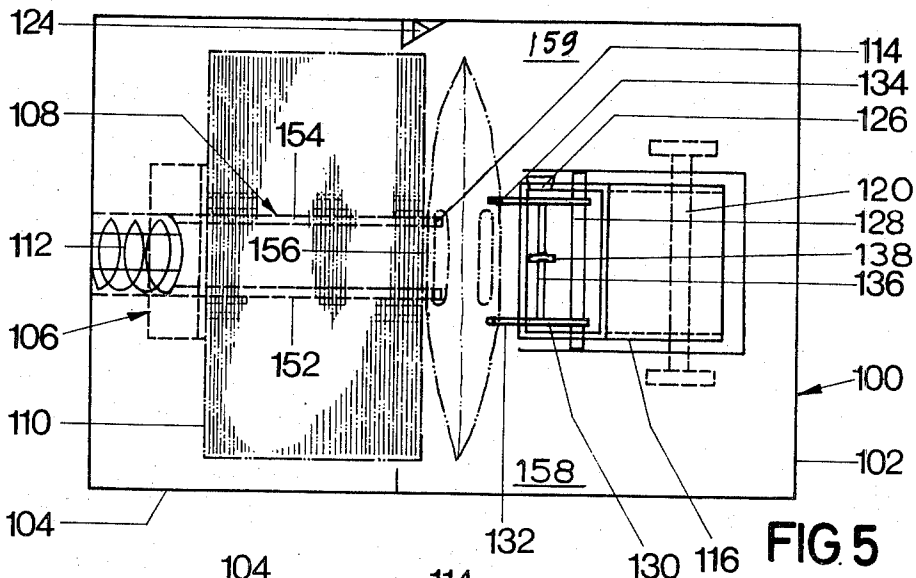

FIG 5

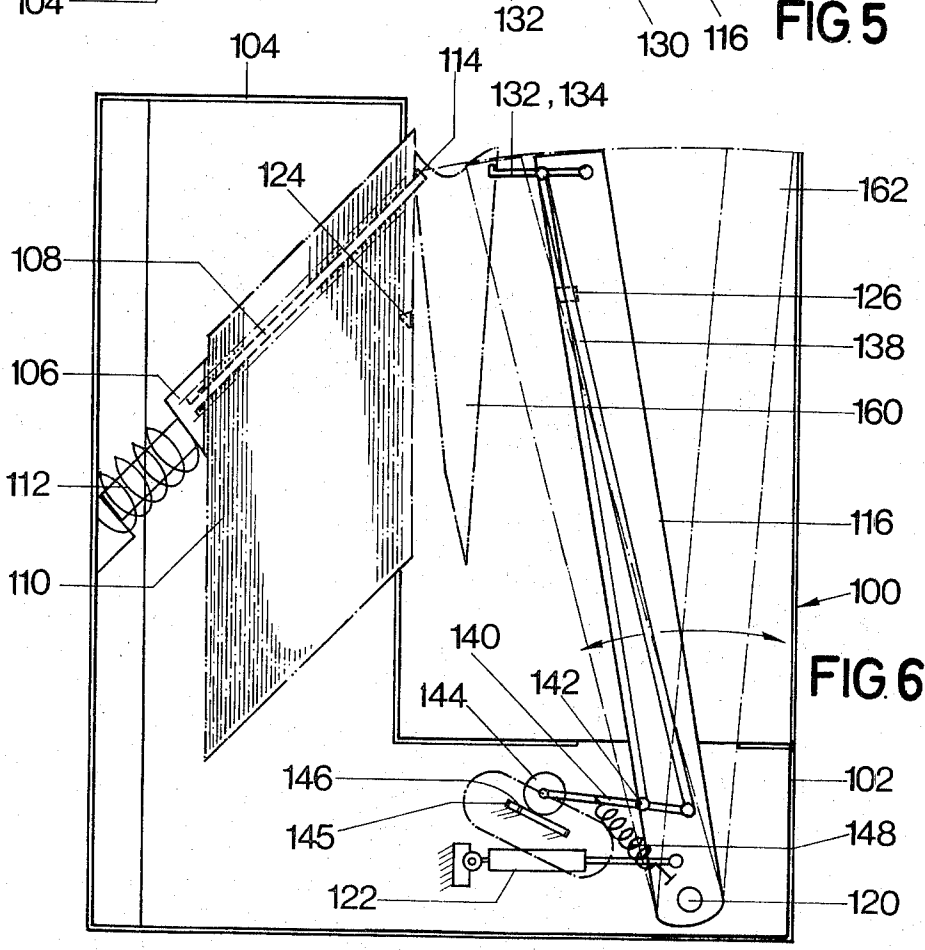

FIG 6

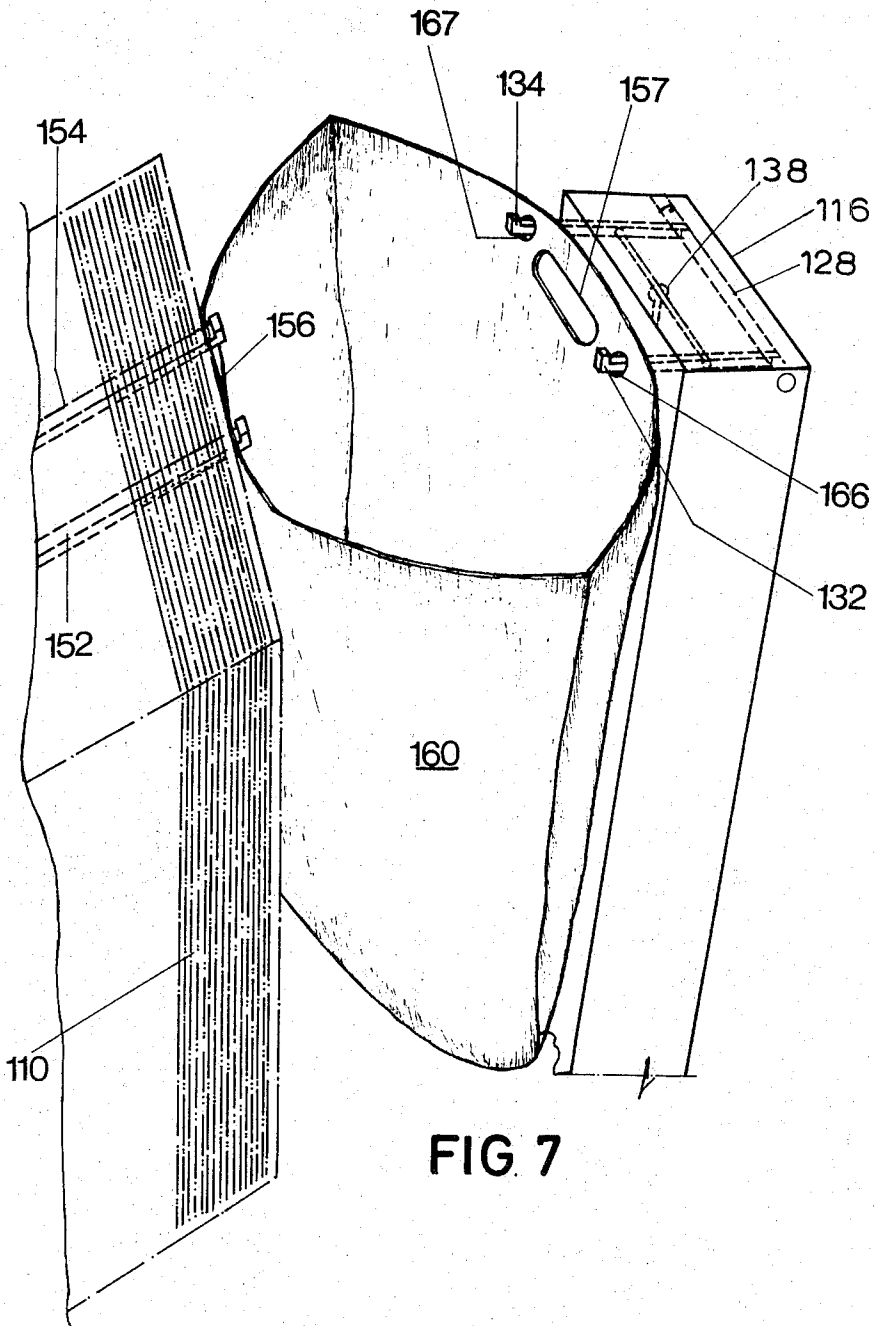

FIG 7

## OPENER AND HOLDER FOR BAGS

### BACKGROUND OF THE INVENTION

The present invention relates generally to means for dispensing and holding carrying bags, such that each separate bag may be held in open position in order to facilitate the loading of the bag. Such means are particularly useful at the cashier desk in self service stores and the like.

More particularly the invention relates to a self feeding and automatically dispensing carrying rack for plastic bags of the kind comprising a bag magazine, a dispensing means and a holding means for the bags such that the bags, one after the other, can be delivered automatically from the magazine and be kept in the open position such that the customer conveniently can fill the merchandise into the bag while it is suspended in the rack. When the customer lifts the bag out of the rack, a new bag will automatically be dispensed for the next customer.

The main object of such devices is thus to provide an improved customer's service, such that the customer is spared from the job of picking up the bag and holding the same in more or less an open position with one hand while putting the merchandise into the bag with the other hand. A further object is to provide a better customer's service by increasing the speed and capacity at the cashier desks, an object which is in the interest of the store as well as for the customer.

There are known several devices having these objects in mind. Known devices include usually a carrying rack with a magazine for a supply of bags and which is provided with rods which are threaded through or are being threaded through the carrying opening handles in the bag in order to provide the dispensing and holding of the bags in open position. There are also known several devices including carrying rods threaded through special through-going holes in the bags. A typical bag holder is shown in U.S. Pat. No. 3 439 891.

Known devices of this kind present, however, one or both of the following shortcomings. Firstly, the customer wholly or partly himself must see that the bag is positioned in correct position in the rack, and secondly, subsequent to the merchandise being filled therein, the bag must be released from the carrying means by lifting the bag in a lateral direction. In other words, known devices of this kind are only at the most partly self-dispensing and require furthermore that the customer must be taught how to use the device. And even if the use is known it involves a substantial shortcoming in that the filled bag is cumbersome to release from the rack, particularly if the releasing movement includes lateral movements.

### SUMMARY OF THE INVENTION

The principal object of the present invention is to provide a device whereby the bags — one after the other — are automatically dispensed and held in the rack in open fashion, i.e., suspended with the face and the back panel of the bag spaced from each other.

A further important object of the invention is to provide a rack wherein the bag subsequent to the filling of merchandise therein may be conveniently removed from the rack by vertical or partly vertical and partly lateral lifting without necessitating lateral releasing movements.

A further object is to provide a special type of bags adapted to be utilized in the apparatus in accordance with the invention.

The apparatus in accordance with the invention is thus of the kind comprising a bag magazine able to hold a supply of bags, a carrying rack with means for feeding and keeping a bag in open position in order to put merchandise therein, and the device in accordance with the invention is generally characterized therein that the bag magazine includes carrying rail means extending through the handle openings of the bags. The device also includes a bag pick-up and holding means supported reciprocally in the vicinity straight forwardly of the magazine rail means and which by actuating are moved substantially horizontally against the foremost bag stored in the magazine, the pick-up means adapted for engaging particular serrations or cut-outs in the outermost bag panel only, returning means for returning the pick-up means to an initial position, the back panel remaining supported on the magazine rail, the bag being held in open position suspended between the magazine rail means and the pick-up means.

In a preferred embodiment the pick-up and holding means comprise two laterally spaced hook means which are adapted to go through complementary serrations in the outermost bag panel which hook means are arranged to move momentarily upwards when in engagement with such panel in order to release the same from the magazine rail. The movements of the various movable parts in the rack are preferably automatically timed, for instance by utilizing magnetic valves, photocells, etc., such that a new bag is automatically dispensed, picked up and held in open position as soon as the preceding one is removed from the rack.

As mentioned it comprises a further necessary feature for operating an apparatus in accordance with the invention that special bags are utilized having suitable adapted serrations or cut-outs in the outer bag panel only and which serrations are arranged adjacent the handle openings in the bag, such that the other, rearly positioned panel has no such special serrations. Thereby, it is secured that the outermost or face panel only is picked up by the pick-up means.

### BRIEF DESCRIPTION OF THE DRAWINGS

The invention comprises also other features which will appear from the following description in connection with the accompanying drawings illustrating some embodiments of the invention and wherein:

FIG. 1 represents a schematic plan view of an apparatus in accordance with the invention, a bag being suspended therein in open position.

FIG. 2 shows a side view along the line I—I in FIG. 1.

FIG. 3 is a fragmentary plan view at an enlarged scale illustrating the pick-up means when it picks up the outermost bag panel of the outermost bag in the bag magazine.

FIG. 4 is a schematic isometric view illustrating primarily the configuration of a bag in accordance with the invention.

FIG. 5 is a schematic plan view of a modified embodiment of an apparatus in accordance with the invention.

FIG. 6 is a schematic sectional side view of the apparatus shown in FIG. 5 and

FIG. 7 is a fragmentary isometric view illustrating a bag held in open position in the rack shown in FIGS. 5 and 6.

#### DETAILED DESCRIPTION OF THE INVENTION

In FIGS. 1 and 2 the reference number 2 designates the apparatus frame which rests on a floor 4 and is suitably attached thereto by means of fastener elements 6. The apparatus or rack is usually mounted below a cashiers desk, in part indicated with stitched lines 7 in FIG. 2. On the rack is mounted in cantilevered fashion a bag magazine 8 which comprises two laterally spaced rails 10 and 12, which foremost have two upwardly pointing stop knobs 14 and 16. Parallely with the rails 10 and 12 is provided a feeding means in the shape of a relatively soft compression spring 18 extending in a guide 20 and at the fore end provided with a compressor-or biasing plate 21 encompassing and journalled on the rails 10 and 12. In this bag magazine 8 may be stored a supply 22 of carrying bags which by means of the handle openings 24 are threaded onto the rails 10 and 12 such that the supply of bags 22 is freely suspended as shown in FIG. 2. The bag supply is urged forwardly by means of the biasing plate 21 and the springs 20 but is hindered from being pushed off the rails 10 and 12 by means of the upright stop knobs 14,16 which at any time rest against the foremost bag.

The second main part of the apparatus comprises as best shown in FIG. 1 a pick-up and holding means 30 comprising an angularly shaped reciprocable shuttle 32 supported vertically between rollers 34 and 36 attached to the frame 2 and supporting the shuttle 32 at the same level as the magazine rails 10 and 12 (The frame 2 is only shown in part for the sake of clarity). The shuttle 32 is furthermore supported between roller pairs 38 and 40, and can be imparted controlled reciprocating movements by means of a motor which in the shown embodiment comprises an electrical linear motor 42 having a rod-shaped anchor element 44 attached to the shuttle at 46. The actuating and operation of this motor is co-ordinated by a pick-up device 50 mounted on the angular arm 52 on the shuttle 32, possibly in connection with not shown relay or magnetic valves which again are controlled by photo-cells (not shown).

As best shown in FIGS. 1, 3 and 4 the pick-up means 50 comprises two laterally spaced, vertically tiltable pick-up arms 54 and 56 which are turnably supported on two support arms 58 and 60 by means of a common pivot rod 62. The pick-up arms 54, 56 are furthermore coupled together below arms 58 and 60 by means of a bolt 64 to which is attached a driving means, for instance in the shape of a magnetic actuator 66, the actuating of which is co-ordinated with the linear motor 42 for the shuttle. The pick-up arms 54 and 56 are at the extremities provided with upwardly pointing picking hooks 68 and 70 adapted to come into engagement with special cut-outs or serrations 72 and 74 provided above the handle openings 75 in the outermost or face bag panel 76 in each of the bags positioned in the bag magazine.

The shown embodiment of an apparatus in accordance with the invention may operate as follows. It is visualized that the supply of bags 22 via the handle openings 24 are threaded onto the rails 10 and 12 in the magazine, such that the handle opening edges on the outermost bag rest against the knobs 14 and 16. The

linear motor 42 is actuated from the initial position as shown in FIGS. 1 and 2, having into effect that the shuttle 32 with the pick-up means 50 moves straight against the magazine rails 10 and 12. When these parts meet, the pick-up hooks 54 and 56, as best shown in FIG. 3, will move through the special cut-outs 72 and 74 on the top side of the handle openings and thereafter hit against the back panel of this bag. At this moment and in this position the actuator 66 is actuated, for instance by means of a magnetic switch 71 mounted on the motor housing 42, such that the pick-up hooks 54 and 56 strike upwards and lift the outermost bag panel 76 off the knobs 14 and 16 on the rails 10 and 12. This releasing action is facilitated in that the pick-up arms when hitting against the adjacent bag panel will press the same somewhat inwards against the adjacent bag on the rails 10 and 12. At this moment and in this position the linear motor 42 is reversed such that the shuttle 32 with the pick-up means 50 together with the outermost bag panel will move back to the initial position as shown in FIGS. 1 and 2 and now with the bag 160 hanging suspended in open position such as shown. The customer may now fill the merchandise just paid for into the bag and thereafter lift the same straight up out of the rack via the handles 75 and 77 which as shown are freely accessible. At the moment when the customer lifts the bag out of the rack a time-switch is released, for instance a pressure switch mounted on the pick-up means 50 or alternatively by means of a photo-cell arrangement controlling the presence of a bag in the position shown in FIG. 2, with the effect that the linear motor is anew reversed such that a new bag is automatically picked up, dispensed and held open in the rack, etc.

It will be understood that a device or rack in accordance with the invention may be modified in various manners within the scope of the inventive idea, and in the foregoing description one has only described the main parts since it will rest within the skill of art to provide for the desired actuating and control of the varying moving parts of the rack. It will thus be understood that the design of the pick-up means together with the complementary cut-outs or serrations 72 and 74 in the outermost bag panel can be configured in several ways. Essentially, the invention utilizes a reciprocating pick-up means which co-operates with complementary serrations in the outermost bag panel, leaving an open bag space between the pick-up means and the bag magazine.

FIGS. 5 and 6 illustrate a lateral view and a plan view, respectively, of a modified embodiment of an apparatus in accordance with the invention and FIG. 7 is a fragmentary view illustrating how the bag in this case is designed, and how it is supported in open fashion in the apparatus rack.

In FIGS. 5 and 6 the reference number 100 designates the supporting frame comprising a bottom part 102 and an upright housing part 104, housing a bag magazine 106 which in this embodiment comprises an upwardly inclined supporting rail means 108 comprising rails 152 and 154 for the supply of bags 110, and which is kept compressed by means of spring means 112 pressing the bag supply upwardly and biased against an upper stop knob 114 at the outer ends of the rail means. In the bottom part 102 of the frame is turnably mounted an upright pendulum or swing arm 116 journalled on a horizontal axis 120. The swing arm may

be imparted reciprocating swinging movements by means of a motor means 122 coupled thereto, for instance an electrical linear motor, a compressed air or hydraulic cylinder or the like, which further may be controlled by a photo-cell arrangement having a light point 124 mounted in the bag mounting space and actuated by a reflex member 126 mounted on the swing arm 116.

Uppermost on the swing arm is on a horizontal shaft 128 mounted the pick-up means 130 which, as best shown in FIG. 5, comprises two mutually spaced pick-up arms 132 and 134, which are coupled together by means of a rod 136, serving simultaneously as linkage for a downwardly extending linkage arm 138 which at the bottom is linked to a tilting arm 140 pivotable on a tap shaft 142 mounted on the swing arm. At the left end of the tilting arm is mounted a roller 144 which is biased against a cam plate 146 by means of a spring 148, the other end of which is attached on the swing arm.

When the swing arm 116 is moved to the left, the roller 144 rolls up along the cam plate 146, having into effect that the pick-up arms initially are moved somewhat downwards against the spring force from the spring 148. At the moment when the pick-up arms move in through the serration in the outermost bag panel in the bag magazine, the roller 144 falls outside the edge 145 on the cam plate 146, having into consequence that the pick-up arms 132, 134 strike upwards and lift this bag panel off the knobs 114 on the magazine rail 108. At the return movement of the swing arm 116 the outer bag panel is held on the pick-up arms by the hooks 155, 157, and the roller 144 goes underneath the cam plate 146. When the merchandise is put into the bag when same is in the position illustrated in FIG. 7, the pick-up arms 132, 134 will be forced down with the effect that the roller 144 anew will enter the top side of the cam plate 146.

An inclined bag magazine as shown implies two advantages. Firstly, one saves space laterally and also in the upward direction. In other words, the magazine may contain more bags per square area of the rack housing 4. A further advantage with this embodiment for the magazine rests in that the picking member gets a better biasing action against the outermost bag panel or the serrations in same, since the bag panels on the inside of the same will not be in complete register with each other but somewhat laterally displaced, such that the handle openings and the special serrations in the outermost bag panels will not be positioned straight backwards.

The apparatus shown in FIGS. 5 and 6 will principally operate analogous with the apparatus shown in FIGS. 1 - 3 with a bag as shown in FIG. 4, but the apparatus of the second embodiment presents, among others, the advantage that it can be made entirely open to both sides 158 and 159, making it possible to remove the bags to either side, and the design makes it possible to make a more compact unit.

FIGS. 5 and 6 illustrate the operative situation wherein a bag 160 has just been picked up by the pick-up arms 132, 134 by a forward action of the swing arm 116, this now being in its return movement. As shown the back panel of the outermost bag is retained by the knobs 114 on the rods 152, 154 in the magazine, while the outer bag panel is supported on the pick-up arms 132, 134 through special holes made in this bag panel.

FIG. 7 illustrates isometrically the situation when the bag 160 is held in the open position. The swing arm 116 has here turned back to the initial position shown with stitched lines 162 in FIG. 6, and the outermost bag panel hangs on the pick-up arms 132, 134 through separate holes 166, 167 provided in the outer bag panel but, as will be understood, not in the rear bag panel, which through the handle 156 is supported on the rails 152 and 154. When the merchandise is filled into the bag and the bag is removed from the rack, the customer grasps the handle openings 156, 157 with his hands, whereafter the bag can be lifted directly out of the rack, straight up or to either side of the rack. When so doing, the photo-cell elements 124, 126 will cause the motor 122 to again be actuated, with the effect that a new bag automatically is picked up from the magazine and is held in the open position such as illustrated in FIG. 7.

What is claimed is:

1. Apparatus for dispensing and holding carrying bags comprising an apparatus frame; a bag magazine for a supply of individual bags, said magazine including carrying rail means for extending through the handle openings in the bags; a carrier means; a bag pick-up and holding means supported reciprocally on said carrier means in the vicinity straight forwardly from said magazine rail means, said pick-up means operative to move substantially horizontally from an initial position to the foremost bag stored in said magazine and engage particular serrations or cut-outs in the outermost bag panel only, said pick-up and holding means comprising two laterally spaced hook members adapted to engage said cut-outs in said outermost bag panel only, said hook members arranged to strike upwardly when in engagement with said panel in order to release said panel from said magazine rail means; and means for returning said carrier means including said pick-up means to said initial position; said apparatus operative to dispense and hold one bag after the other in open position suspended between said magazine rail means and said pick-up means.

2. Apparatus in accordance with claim 1 wherein said carrier means comprises an angularly shaped shuttle having one arm constituting support for said pick-up means, and one second armsupported parallelly with the axis through said magazine and said pick-up means and connected to a motor means operative to give said shuttle a reciprocating movement giving the pick-up means a reciprocating movement from said initial position to a position in engagement with the outmost bag on the magazine rail means and back to said initial position, and means controlling the movements.

3. Apparatus in accordance with claim 1, wherein said magazine includes spring means urging the supply of bags toward the outer ends of said rail means, said rail means provided with upwardly pointing stop knobs at the outer end thereof.

4. Carrying bag to be used in apparatus in accordance with claim 3, said bag at one of the handle openings therein provided with two mutually spaced cut-outs or serrations situated to provide engagement openings for said pick-up means.

5. Apparatus for dispensing and holding carrying bags comprising an apparatus frame; a bag magazine for a supply of individual bags, said magazine including carrying rail means for extending through the handle openings in the bags; a carrier means; a bag pick-up

7

and holding means supported reciprocally on said carrier means in the vicinity straight forwardly from said magazine rail means, said pick-up means operative to move substantially horizontally from an initial position to the foremost bag stored in said magazine and engage particular serrations or cut-outs in the outermost bag panel only; and means for returning said carrier means including said pick-up means to said initial position; said apparatus operative to dispense and hold one bag after the other in open position suspended between said magazine rail means and said pick-up means; said carrier means comprising an upright, pivotable swing arm which is pivotally supported about a horizontal axis at the lower part of said frame; said swing arm connected to a motor means for carrying out reciprocable pivotable movement from said initial position to a position in the vicinity of said magazine rail means; said pick-up means being mounted at the upper end of said swing arm; said pick-up means being operative for carrying out upward movement when in engagement with said

8

outermost bag panel on said magazine rail means in order to release said outermost bag panel from said magazine rail means; and means for controlling the movements of said swing arm and pick-up means.

5 6. Bag to be used in apparatus in accordance with claim 5, said bag provided with one individual opening on either side of one of said handle openings in the bag, said individual openings providing access for said pick-up means.

10 7. Apparatus in accordance with claim 5, wherein said pick-up means is coupled to linkage and cam means biased on said frame of said apparatus, operative to give said pick-up means the desired movement correlated with the movement of said swing arm.

15 8. Apparatus in accordance with claim 7, wherein said movements are controlled by photo cell means controlling the presence of a bag in the space between said pick up means and said magazine.

\* \* \* \* \*

20

25

30

35

40

45

50

55

60

65