

(No Model.)

2 Sheets—Sheet 1.

W. H. SMITH.

MECHANISM FOR FLANGING MANHOLES OF BOILERS.

No. 525,474.

Patented Sept. 4, 1894.

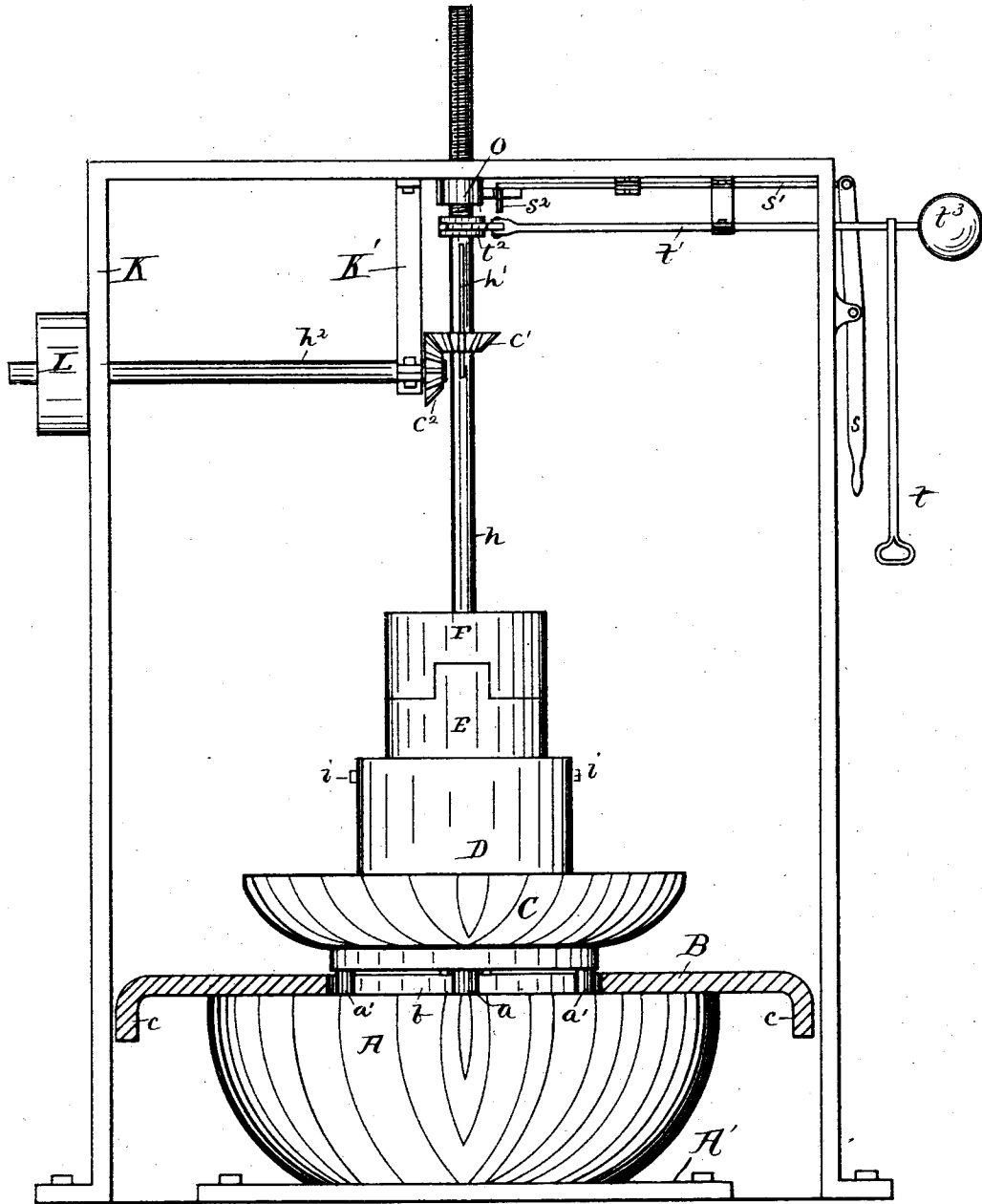

Fig. 1

WITNESSES:

J. E. Jesseyman.
Lester L. Allen.

INVENTOR
William H. Smith.

BY
R. J. Marty
ATTORNEY.

(No Model.)

2 Sheets—Sheet 2.

W. H. SMITH.

MECHANISM FOR FLANGING MANHOLES OF BOILERS.

No. 525,474.

Patented Sept. 4, 1894.

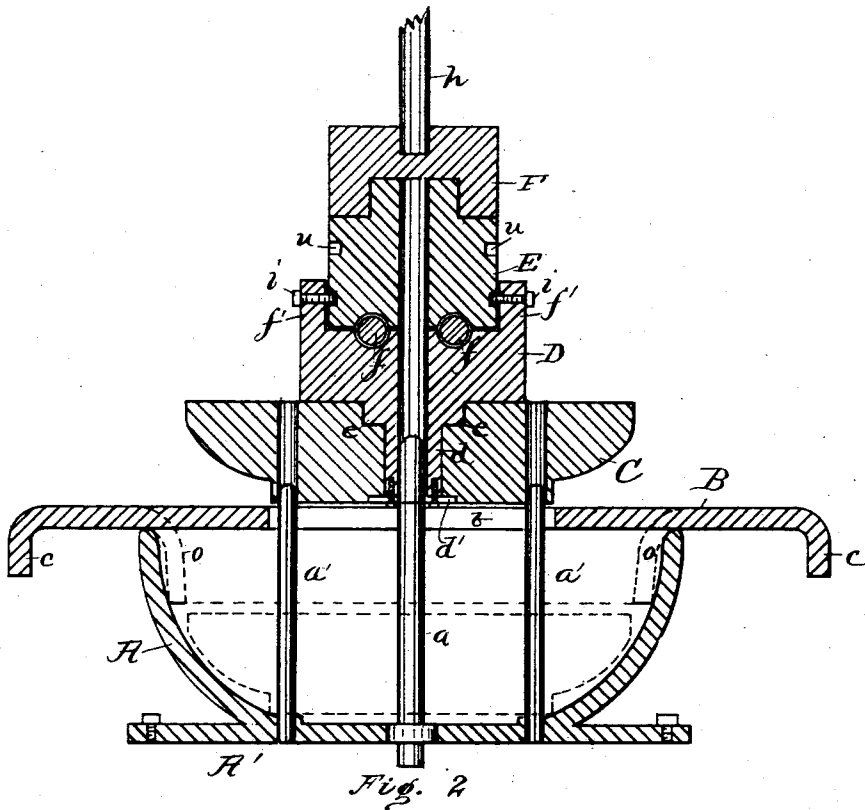

WITNESSES:
J. C. Peaseyman
Lester L. Allen

INVENTOR
William H. Smith
BY
R. J. McCarty
ATTORNEY

UNITED STATES PATENT OFFICE:

WILLIAM H. SMITH, OF DAYTON, OHIO.

MECHANISM FOR FLANGING MANHOLES OF BOILERS.

SPECIFICATION forming part of Letters Patent No. 525,474, dated September 4, 1894.

Application filed March 31, 1894. Serial No. 505,853. (No model.)

To all whom it may concern:

Be it known that I, WILLIAM H. SMITH, of Dayton, county of Montgomery, State of Ohio, have invented a new and useful Improvement in Mechanism for Flanging Manholes of Boilers; and I do declare the following to be a full, clear, and exact description of the invention, such as will enable others skilled in the art to which it appertains to make and use the same, reference being had to the accompanying drawings, and to the letters of reference marked thereon, which form a part of this specification.

My invention relates to mechanism for flanging the edges of man-holes in boiler-heads, and also for flanging the edges of any openings circular or otherwise, such for example, as the nozzles formed in boilers. These man-holes, and nozzles, when flanged by hand, generally require three or more men to do the work, and about twenty minutes' time is consumed in flanging one man-hole.

The object of the present invention, is to provide quicker means for doing this work; to this end, I have provided mechanism by the use of which, a man-hole may be neatly and uniformly flanged in, say about six minutes' time, and the work may be done by one man with a little assistance.

For a description of my invention reference is made to the accompanying drawings, forming part of the specification, in which—

Figure 1 is a side elevation of my invention, associated with the mechanical adjuncts by which it is operated. The boiler-head to be flanged is shown in section; Fig. 2 a vertical section.

There are shown in the drawings, several parts that are old, therefore, they form no part of my invention; to wit, the bowl minus the pins, the lever mechanism, and the supporting frame.

A represents a cast iron bowl, of elliptical shape, having an integral flange A' which is screwed to any desirable support.

(a) and (a') represent pins projecting vertically from the bottom of said bowl, the functions of which are to guide the block C as it enters the bowl.

B is the boiler-head resting on the bowl A,

and having the man-hole punched therein, as at (b), and the outer edge turned as at (c) to receive the rivets by which it is secured to the boiler.

C is an elliptical shaped block, with vertical openings for the pins (a') and a central opening forming an annular shoulder (e), for the stem (d) of the chuck D.

(d') is a plate screwed to the bottom of the stem (d) to prevent the block C from dropping, and by means of which blocks of different diameters may be used with the same chuck, this chuck is provided with ball-bearings (f) and an annular vertical flange (f') forming a seat for the clutch member E to which it is secured by screws (i) passing through the flange (f') and entering an annular circumferential groove in the clutch member E, whereby said clutch is permitted to turn upon the balls, but is prevented from leaving the chuck vertically. The clutch E is provided with a central opening as is also, the chuck D, for the passage of the pin (a) when the drop mechanism is lowered into the bowl as hereinafter described.

F is the upper member of the clutch, keyed to a vertical shaft (h), having a longitudinal key-seat (h') in which a bevel gear (c') is keyed against an independent rotary movement. The upper portion of said vertical shaft is screw-threaded to engage with the nut O, presently referred to.

(c²) is a second bevel gear meshing with gear (c') and keyed to the horizontal shaft (h²) having bearings in a hanger (k') and the supporting frame (k).

L is a belt pulley keyed to the shaft (h²) through the agency of which, power is transmitted to drive the block C downward into the bowl, to form the annular flange, (o,) shown in dotted lines in Fig. 2.

O is a screw-threaded nut attached to the supporting frame, in which the shaft (h) moves; in order to enable a quick elevation of said shaft and the clutch F, after the flange has been completed, this nut is formed with a hinged joint and may be opened by pressing the hand lever (s) inwardly, which draws outwardly, the horizontal rod (s') to the inner end of which are attached, a series of pins (s²)

that operate to open and close the nut; this nut and the mechanism for opening and closing it, are old features, therefore, it is not thought necessary to describe them further.

5 The shaft (*h*) and the clutch thereon are elevated when the nut is opened upon its hinge, by drawing on the rod (*t*) attached to the horizontal rod (*t'*) in the inner end of which there is a clamp that surrounds a grooved collar (*t²*) fixed to the shaft (*h*).

10 (*t³*) is an equalizing weight attached to the outer end of rod (*t'*).

Briefly stated, the operation is as follows: The boiler head is punched to form the man-
15 hole, the edges of the hole upon which the flange is formed are heated, the boiler-head is then placed in position on the bowl, the block is then driven into the bowl, until it clears the flange, which is formed by the block pressing
20 downwardly the edge of the man-hole; the moment the work of flanging is performed, the block drops by gravity to the bottom of the bowl, as appears in broken lines in Fig. 2, and the clutches become instantly disengaged so that power is released from the block
25 after it has performed its work. The removal of the block to repeat the operation is effected by inserting pins in the cavities (*u*) in the sides of the chuck and lifting said chuck and
30 therewith the block.

The cost of keeping the device in repair is trifling; the parts lasting, practically, until they are worn out; the bearings all being constructed of cast steel, and hardened.

Having described my invention, I desire to 35 claim—

1. The combination with the bowl A having vertical pins (*a*) and (*a'*); of the block C having a central opening formed with an annular shoulder, and openings to receive the pins (*a'*), 40 the chuck D having a stem (*d*) adapted to enter the central opening in the block and to receive the pin (*a*), the clutch member E attached to the chuck, ball-bearings between said clutch member and chuck, and the clutch 45 member F fixed to the shaft (*h*), whereby the block is lowered to form the flange on a man-hole, substantially as described.

2. The combination of the bowl A, the block C adapted to enter said bowl on guides, the 50 chuck D mounted in said block, and the clutch member E mounted on ball-bearings in said chuck, as described.

In testimony whereof I have hereunto set my hand this 28th day of February, 1894.

WM. H. SMITH.

Witnesses:

R. J. MCCARTY,
L. L. ALLEN.