



(11) **EP 2 006 426 B1**

(12) **EUROPEAN PATENT SPECIFICATION**

(45) Date of publication and mention of the grant of the patent:
23.12.2009 Bulletin 2009/52

(51) Int Cl.:
D01H 5/56^(2006.01) D01H 5/44^(2006.01)

(21) Application number: **08010067.0**

(22) Date of filing: **02.06.2008**

(54) **Side plate for drafting device**

Seitenplatte für Streckwerk

Plaque latérale pour dispositif d'étirage

(84) Designated Contracting States:
CH DE LI

(30) Priority: **20.06.2007 JP 2007162645**

(43) Date of publication of application:
24.12.2008 Bulletin 2008/52

(73) Proprietor: **Murata Machinery, Ltd.**
Kyoto 601 (JP)

(72) Inventors:
• **Sakamoto, Naotaka**
Kyoto-shi
Kyoto (JP)

- **Yokota, Itaru**
Kyoto-shi
Kyoto (JP)
- **Ota, Naritoshi**
Kyoto-shi
Kyoto (JP)

(74) Representative: **Liedl, Christine et al**
Hansmann & Vogeser
Albert-Rosshaupter-Strasse 65
81369 München (DE)

(56) References cited:
DE-A1- 4 318 025 GB-A- 190 923 392
JP-U- 4 123 268 US-A- 5 303 454

EP 2 006 426 B1

Note: Within nine months of the publication of the mention of the grant of the European patent in the European Patent Bulletin, any person may give notice to the European Patent Office of opposition to that patent, in accordance with the Implementing Regulations. Notice of opposition shall not be deemed to have been filed until the opposition fee has been paid. (Art. 99(1) European Patent Convention).

Description

Field of the Invention

[0001] The present invention relates to a side plate comprising roller support members provided in a draft device.

Background of the Invention

[0002] In a draft device in a spinning machine, appropriate drafting may be prevented by an increased amount of floating fibers having failed to be nipped by draft rollers. Thus, in this case, an appropriate arrangement distance (gauge) needs to be set between the draft rollers. Furthermore, the gauge between the draft rollers to be set varies depending on, for example, the type or application of fibers to be spun. Thus, a side plate is conventionally used to position the plurality of draft rollers in the draft device.

[0003] A side plate of this kind is disclosed in, for example, the Unexamined Japanese Utility Model Application Publication (Jikkai-Hei) No. 4-123268. The Unexamined Japanese Utility Model Application Publication (Jikkai-Hei) No. 4-123268 discloses a gauge adjusting mechanism configured as described below. That is, the gauge adjusting mechanism has roller shaft support members that individually support roller shafts of top rollers positioned behind a second top roller around which an apron band is installed. The roller shaft support members are movably mounted to a side plate of a cradle. The gauge between the rollers can be adjustably changed by moving the roller shaft support members forward and backward with respect to the draft device. According to the Unexamined Japanese Utility Model Application Publication (Jikkai-Hei) No. 4-123268, this configuration makes it possible to adjust the gauge to a desired value to eliminate the need to prepare various side plates. This also eliminates the need to replace the side plate with a different one and mount the different side plate again every time the gauge is changed.

[0004] In the configuration of the Unexamined Japanese Utility Model Application Publication (Jikkai-Hei) No. 4-123268, the support member for the gauge adjusting mechanism is movably mounted to the side plate with slits and screws. Consequently, to accurately place the draft rollers at positions where the desired gauge is set in order to prevent possible uneven drafting, the support members must be screwed shut with the positions of the support members precisely adjusted within the range of the size of the slit. Therefore, a gauge changing and fine-tuning operation is complicated and requires a substantially long time and substantially much man-hour.

[0005] Document DE 4318025 A also discloses a roller support device, in which support members have to be set individually for individual rollers.

[0006] In particular, in a large-scale spinning factory or the like, where the type of fibers to be spun is changed,

the gauge is changed in each of a large number of spinning units. Thus, there has been a strong desire for a reduction in the time and man-hour required for the gauge changing operation.

Summary of the Invention

[0007] Thus, an object of the present invention is to provide a side plate which enables a reduction in costs and which allows gauges to be easily and reliably adjusted.

[0008] The problems described above are solved by the invention according to claim 1. Now, the means of the invention will be described.

[0009] A first aspect of the present invention provides the following configuration of a side plate used to position a plurality of draft rollers in a draft device. That is, the side plate comprises a fixed member and a movable member. The fixed member comprises roller support portions that support the draft rollers, and the fixed member is mounted to the draft device at a fixed position. The movable member comprises roller support portions that support the draft rollers, and a position of the movable member with respect to the draft device is changeable within a predetermined stroke. When the movable member is positioned at a first end of the stroke range, a preset first pitch is provided between the draft roller on the fixed member side and the draft roller on the movable member side. On the other hand, when the movable member is positioned at a second end of the stroke range, a preset second pitch different from the first pitch is provided between the draft roller on the fixed member side and the draft roller on the movable member side.

[0010] With this configuration, the gauge between the draft roller on the fixed member side and the draft roller on the movable member side can be easily changed by changing the mounting position of the movable member between the first end and second end of the stroke range. Furthermore, the first pitch or the second pitch can be accurately provided by positioning the movable member at the first end or second end of the stroke range. Thus, the operation of fine-tuning the position of the movable member need not be performed. This also facilitates the gauge changing operation. Furthermore, the gauge can be adjusted without the need to remove the draft rollers from the roller support portions of the fixed member and the movable member. Therefore, the effort and time required for the gauge changing operation can be reduced.

[0011] Preferably, in the side plate, the movable member comprises a plurality of roller support portions, and moving the movable member integrally moves the plurality of roller support portions.

[0012] With this configuration, simply moving the movable member enables the gauge between the draft roller on the fixed member side and the draft roller on the movable member side to be easily changed while maintaining the gauge between the draft rollers supported by the movable member. This allows the efficiency of the gauge

changing operation to be improved.

[0013] The side plate is preferably configured such that with the fixed member fixed to the draft device, the movable member is replaceable with another movable member having roller support portions arranged at a distance from each other which is different from the distance between the roller support portions of the first movable member.

[0014] Thus, to change the gauge between the draft rollers supported by the movable member, it is only necessary to replace the movable member with a different one, with the fixed member remaining fixed to the draft device. Furthermore, since the movable member can be replaced with a different one without the need to remove the draft rollers supported by the fixed member, the gauge changing operation can be efficiently performed. Additionally, the gauge can be changed to any of various values simply by moving and replacing the movable member with a different one with the fixed member remaining unchanged. This enables a reduction in the manufacturing costs of the side plate.

[0015] Preferably, in the side plate, the movable member has an abutting surface that contacts with the fixed member to position the movable member at the appropriate end of the stroke range.

[0016] Thus, the first pitch and the second pitch can be reproducibly obtained using the simple configuration.

[0017] Preferably, in the side plate, a slot or a groove is formed in at least one of the fixed member and the movable member, and an end of the slot or groove is used to position the movable member at the appropriate end of the stroke range.

[0018] Thus, the first pitch and the second pitch can be reproducibly obtained using the simple configuration.

[0019] Preferably, in the side plate, the movable member comprises a slot having one open end, and the movable member is mounted to the draft device or the fixed member with a shaft portion of a mounting member inserted through the slot.

[0020] With this configuration, to be replaced with a different one, the movable member can be removed from the draft device without the need to remove the mounting member. Consequently, the operation of attaching/removing the mounting member can be omitted, facilitating the operation of replacing the movable member with a different one.

[0021] The side plate preferably has the following configuration. That is, the fixed member comprises a reference display portion, and the movable member comprises two position display portions. When the movable member is positioned at one of the ends of the stroke range, the reference display portion aligns with one of the two position display portions.

[0022] With this configuration, reading the reference display portion and the position display portions makes it possible to easily determine whether or not the movable member is reliably positioned at the appropriate end of the stroke range.

[0023] Preferably, in the movable member of the side plate, the first pitch and the second pitch are displayed close to the respective position display portions as numbers.

5 **[0024]** This configuration makes it possible to easily determine which gauge has been provided between the draft roller on the fixed member side and the draft roller on the movable member side.

10 **[0025]** A second aspect of the present invention provides a draft device comprising the side plate and a textile machine comprising the draft device.

15 **[0026]** Other features, elements, processes, steps, characteristics and advantages of the present invention will become more apparent from the following detailed description of preferred embodiments of the present invention with reference to the attached drawings.

Brief Description of the Drawings

20 **[0027]**

Figure 1 is a front view of a spinning machine according to an embodiment of the present invention. Figure 2 is a side view showing the condition of a draft device.

25

Figure 3 is a diagram of an entire side plate according to an embodiment of the present invention.

Figure 4 is side view showing that a back member is positioned at a first end of a stroke range.

30

Figure 5 is an enlarged view showing a part of Figure 4 enclosed by a chain line.

Figure 6 is a side view showing that the back member is positioned at a second end of the stroke range.

35

Figure 7 is an enlarged view showing a part of Figure 6 enclosed by a chain line.

Figure 8 is a side view illustrating an operation of changing the gauge between a middle roller and a third roller.

40

Figure 9 is a side view illustrating an operation of removing the back member of the side plate for replacement.

Figure 10 is a side view illustrating an operation of mounting a new back member.

45 Detailed Description of the Preferred Embodiments

[0028] A preferred embodiment of the present invention will be described below with reference to the drawings. Figure 1 shows a spinning machine 1 serving as a textile machine and comprising a large number of juxtaposed spinning units (yarn processing units) 2.

50

[0029] As shown in Figure 1, each of the spinning units 2 has a draft device 7, a spinning device 9, a yarn feeding device 11, and a winding device 12 as main components.

55

The spinning unit 2 is configured such that the draft device 7 is provided near an upper end of a casing 6 of the spinning machine 1 main body so that a fiber bundle 8 fed from the draft device 7 is spun by the spinning device

9. A spun yarn 10 discharged by the spinning device 9 is fed downward by the yarn feeding device 11. The spun yarn 10 then passes through a clearer (yarn defect detector) 52 which detects a defect in the yarn and which cuts the defective yarn to remove the defective yarn part. The spun yarn 10 is then wound by the winding device 12 to form a package 45.

[0030] The spinning machine 1 is equipped with a blower box 80 and a motor box 81. Furthermore, although not shown in the figure, the spinning machine 1 comprise a yarn splicing vehicle provided so as to travelable in a direction in which the spinning units 2 are arranged and a doffing vehicle provided so as to be travelable independently of the yarn splicing vehicle.

[0031] Figure 2 shows an enlarged side view of the draft device 7, the spinning device 9, and the yarn feeding device 11. The draft device 7 comprises a draft roller that draws a sliver 13 into a fiber bundle 8. The draft roller is composed of a top roller and a bottom roller arranged opposite each other.

[0032] The top roller is composed of four rollers, that is, a back roller 14, a third roller 15, a middle roller 16 around which an apron belt 17 is installed, and a front roller 18. These top rollers 14, 15, 16, 18 are mounted to a cover-like cradle 20 provided in the draft device 7. On the other hand, a bottom roller is composed of four rollers, a back bottom roller 24, a third bottom roller 25, a middle roller 26 around which an apron belt 27 is installed, and a front bottom roller 28. The bottom rollers 24, 25, 26, 28 are mounted to the draft device 7 main body and arranged opposite the top rollers 14, 15, 16, 18.

[0033] A spring box (not shown in the drawings) is provided inside the cradle 20 to bias the top rollers 14, 15, 16, 18 so as to press the top rollers 14, 15, 16, 18 against the bottom rollers 24, 25, 26, 28. This allows the sliver 13 to be nipped between the top rollers 14, 15, 16, 18 and the bottom rollers 24, 25, 26, 28.

[0034] The respective top rollers 14, 15, 16, 18 are positioned by a side plate 70 mounted to a side surface of the cradle 20. This sets the distances (gauges) between the nip points of the top rollers 14, 15, 16, 18 for the sliver to predetermined values. Each of the cradles 20 is provided for two spinning units 2 as shown in Figure 2, and the side plate 70 is mounted to each of the opposite surfaces of the cradle 20. The details of the configuration of the side plate 70 will be described below.

[0035] In the above-described configuration, the sliver 13 fed to the draft device 7 is drawn by the draft rollers, rotationally driven at different speeds, and is thus formed into the fiber bundle 8, which is then fed to the spinning device 9, as shown in Figure 2. The spinning device 9 pneumatically spins the fiber bundle 8 fed from the draft device 7. The pneumatically spun fiber bundle 8 is fed to the yarn feeding device 11 as the spun yarn 10.

[0036] The yarn feeding device 11 comprises a delivery roller 39 supported by the casing of the spinning machine 1 main body and a nip roller 40 provided so as to freely contact and leave the delivery roller 39. In this con-

figuration, the spun yarn 10 discharged by the spinning device 9 is sandwiched between the delivery roller 39 and the nip roller 40, and the delivery roller 39 is then rotationally driven. The spun yarn 10 can thus be fed to the winding device 12.

[0037] The cradle 20 is provided so as to be pivotable around a pivoting shaft portion 29 with respect to the draft device 7. Furthermore, a cradle handle 23 is fixed to the cradle 20. In this configuration, while the spinning machine 1 is in operation, the cradle 20 is in the position shown in Figure 2 and is locked by a lock mechanism (not shown in the drawings). The cradle 20 is opened by unlocking the lock mechanism and raising the cradle handle 23. In this condition, the following operations are performed: a maintenance operation including replacement of the top roller 14, 15, 16, 18 or the bottom roller 24, 25, 26, 28, an operation of adjusting the gauge between the draft rollers as described below, and the like.

[0038] Now, the side plate 70, mounted to the cradle 20, will be described. Figure 3 shows a diagram of the entire side plate 70 according to one embodiment of the present invention. As shown in Figure 3, the side plate 70 is divided into a front member (fixed member) 21 and a back member (movable member) 22. Each of the front member 21 and the back member 22 is made of metal and formed like a plate having a predetermined thickness.

[0039] The front member 21 comprises a front roller support portion 78 that supports the front roller 18 and a middle roller support portion 76 that supports the middle roller 16. Furthermore, the back member 22 comprises a third roller support portion 75 that supports the third roller 15 and a back roller support portion 74 that supports the back roller 14. The roller support portions 74, 75, 76, 78 have recess portions respectively. The top rollers 14, 15, 16, 18 can be positioned by positioning and supporting bearing portions of the respective top rollers 14, 15, 16, 18 in the recess portions.

[0040] The front roller support portion 78 and the middle roller support portion 76 are both formed in the front member 21. Consequently, the gauge between the front roller 18 and the middle roller 16 is unchangeable. Similarly, the third roller support portion 75 and the roller support portion 74 are both formed in the back member 22. Consequently, the gauge between the third roller 15 and the back roller 14 is unchangeable.

[0041] The positions of the roller support portions 74, 75, 76, 78 are such that the gauge between the front roller 18 and the middle roller 16, and the gauge between the third roller 15 and the back roller 14 are set equal to preset predetermined distances. However, plural types of back member 22 are manufactured and prepared which have different gauges between the third roller 15 and the back roller 14.

[0042] Circular penetrating mounting holes 69, 69 are formed in the front member 21 of the side plate 70. The front member 21 is mounted to the cradle 20 by threadably inserting screws 91, 92 through the mounting holes

69, 69 (see Figure 4). The threadable insertion of the screws immovably fixes the side plate 70 to the cradle 20. Consequently, the front roller support portion 78 and the middle roller support portion 76 are fixed and the positions thereof are unchangeable.

[0043] As shown in Figure 3, a notch portion 63 and a slot portion 61 are formed in the back member 22 of the side plate 70. The notch portion 63 and the slot portion 61 are formed to be elongate along a direction in which the roller support portions 74, 75, 76, 78 are arranged (the direction in which the sliver 13 travels). The notch portion 63 is shaped like a slot that is open at one end thereof which is closer to the front member 21. Furthermore, the slot portion 61 is located at an end of the back member 22 which is farther from the front member 21.

[0044] The back member 22 is fixed to the cradle 20 by threadably inserting screws 93, 94 as mounting members through the notch portion 63 and the slot portion 61 (see Figure 4). Furthermore, as shown in Figure 3, the back member 22 comprises an abutting portion 62 having a surface (abutting surface) that can be contacted with an end surface of the front member 21.

[0045] The cradle 20 has internally threaded holes formed therein and into which the screws 91 to 94 are threadably inserted. An inner portion of the cradle 20 is padded at the positions of the internally threaded holes by welding or the like to so as to offer an appropriate strength.

[0046] The back member 22 can be moved within a predetermined stroke range along the notch portion 63 and the slot portion 61 by loosening the screws 93, 94 (Figure 4) for mounting. This means that the gauge between the middle roller 16 and the third roller 15 can be changed with the gauge between the front roller 18 and the middle roller 16, and the gauge between the third roller 15 and the back roller 14 maintained constant.

[0047] As the back member 22 is moved closer to the front member 21, the abutting surface of the abutting portion 62 comes into contact with the front member 21 to prevent the back member 22 from moving further toward the front member 21 side as shown in Figure 4. This defines a first end of the stroke range of the back member 22. In this condition, as shown in Figure 5 that is an enlarged view of a part of Figure 4 enclosed by a chain line, a shaft portion 79 of the screw 94 inserted through the slot portion 61 is positioned in the middle of the slot portion 61 in a longitudinal direction thereof.

[0048] The position of the roller support portions 74, 75, 76, 78 and the position of the abutting surface of the abutting portion 62, and the like are set such that in the condition in Figure 4, in which the back member 22 is positioned at the first end of the stroke range, a preset first pitch (gauge) P1 is provided between the middle roller 16 and the third roller 15.

[0049] On the other hand, as the back member 22 is moved away from the front member 21 and when a condition shown in Figure 6 is established, the shaft portion 79 of the screw 94 comes into contact with one end of

the slot portion 61 (see Figure 7 that is an enlarged view of a part of Figure 6 which is enclosed by a chain line). This inhibits the back member 22 from moving away from the front member 21 to define a second end of the stroke range of the back member 22.

[0050] The positions of the roller support portions 74, 75, 76, 78, the slot portion 61, the screw 94, and the like are set such that in the condition in Figure 6, in which the back member 22 is positioned at the second end of the stroke range, a preset second pitch (gauge) P2 is provided between the middle roller 16 and the third roller 15. Furthermore, the second pitch P2 is set larger than the first pitch P1 (Figure 4) provided when the back member 22 is positioned at the opposite end of the stroke range.

[0051] Thus, by performing a simple operation of moving and positioning the back member 22 at the first end or second end of the stroke range and then tightening the screw, it is possible to obtain the preset first pitch P1 or preset second pitch P2 as the gauge between the middle roller 16 and the third roller 15. In particular, since the two pitches P1, P2 are set at the first end and second end of the stroke range, it is unnecessary to perform a complicated operation of precisely adjusting the position of the back member 22 in the middle of the stroke range. Furthermore, desired pitches can be reproductively obtained.

[0052] As shown in Figure 3, the front member 21 has a protruding portion 71 protruding toward the back member 22 and the back member 22 has a recess portion formed at a position corresponding to the protruding portion 71. The protruding portion 71 of the front member 21 comprises a reference line 64 as a reference display portion. On the other hand, the back member 22 comprises a long gauge line 65 and a short gauge line 67 located beside the recess portion and serving as position display portions. A long gauge display portion 66 and a short gauge display portion 68 are provided close to the long gauge line 65 and the short gauge line 67, respectively. The display portions 66, 68 directly display the actual gauges between the middle roller 16 and the third roller 15 (first pitch P1 and second pitch P2), for example, as numerical values in millimeters.

[0053] The positions of the reference line 64, the long gauge line 65, and the short gauge line 67 are set such that moving the back member 22 to the first end of the stroke range aligns the reference line 64 with the short gauge line 67 as shown in Figure 4, whereas moving the back member 22 to the second end of the stroke range aligns the reference line 64 with the long gauge line 65 as shown in Figure 6. Thus, reading the positional relationship between the reference line 64 and the two gauge lines 67, 65 makes it possible to easily determine whether or not the back member 22 is positioned at the appropriate end of the stroke range.

[0054] An operation of changing the gauge between the middle roller 16 and the third roller 15 is performed as described below. That is, with the cradle 20 open as shown in Figure 8, a tool is used to loosen the screws

93, 94 fixing the back member 22. The back member 22 is then moved from the first end to second end of the stroke range. The screws 93, 94 are tightened again for fixation. An operation of changing the gauge between the middle bottom roller 26 and the third bottom roller 25 shown in Figure 2 is also appropriately performed with the cradle 20 open. Subsequently, the cradle 20 is closed to complete the pitch changing operation.

[0055] The pitch changing operation can be performed with the top rollers 14, 15, 16, 18 held in the roller support portions 74, 75, 76, 78 of the side plate 70 as shown in Figure 8. This eliminates the need for an operation of removing and then mounting the top rollers 14, 15, 16, 18 again. The gauge changing operation is thus facilitated.

[0056] When the back member 22 is moved, the third roller 15 and the back roller 14 move simultaneously with the back member 22. Thus, a position on which the bias force of the spring box, provided in the cradle 20, acts is pre-adjusted such that an appropriate bias force can be exerted even though the third roller 15 or the back roller 14 moves.

[0057] On the other hand, changing the pitch between the third roller 15 and the back roller 14 requires replacement of the back member 22 and is thus performed as described below.

[0058] That is, first, with the cradle 20 open, the third roller 15 and the back roller 14 (see Figure 2) are removed from the roller support portions 75, 74 of the back member 22. Then, a tool is used to appropriately loosen the screw 93 (see Figure 4) locking the back member 22 at the notch portion 63. Furthermore, the screw 94 locking the back member 22 at the slot portion 61 is removed.

[0059] Then, in the condition shown in Figure 9, the back member 22 is pulled out and away from the front member 21 as shown the arrow. Then, the shaft portion of the screw 93 is pulled out from the open end of the notch portion 63. Thus, with the screw 93 remaining attached to the cradle 20, the back member 22 can be easily removed from the cradle 20.

[0060] Then, as shown in Figure 10, a back member 22X in which the gauge between the third roller 15 and the back roller 14 is different from that in the removed back member 22 is set such that the shaft portion of the screw 93 is inserted into the notch portion 63. The screw 94 is inserted into the slot portion 61 again. Then, with the screws 93, 94 remaining loose, the back member 22X is positioned at the first end or second end of the stroke range. Subsequently, the screws 93, 94 are tightened to fix the back member 22X to the cradle 20.

[0061] As shown in Figures 9 and 10, this pitch changing operation does not require the replacement of the front member 21 and can be performed with the top rollers 18, 16 on the front member 21 side held in the roller support portions 78, 76, respectively. This eliminates the need for an operation of removing and then mounting the appropriate parts again. The gauge changing operation is thus facilitated.

[0062] For example, various mechanisms such as a cleaner which are used to clean the surfaces of the top rollers 14, 15, 16, 18 are arranged close to the screw 93. Thus, a work space for the attachment/removal of the screw 93 often fails to be provided. In this connection, the back member 22 (22X) according to the present embodiment comprises the slot-like notch portion 63 with the open portion. Thus, simply by inserting a tool such as a driver into a thread groove in a head portion of the screw 93 to loosen the screw 93, the shaft portion of the screw 93 can be inserted into or removed from the notch portion 63 via the open portion without completely removing the screw 93 from the cradle 20. Therefore, the back member 22 can be easily replaced with a different one.

[0063] As shown above, in the draft device 7 according to the present embodiment, the side plate 70, used to position the plurality of draft rollers (top rollers 14, 15, 16, 18), is configured as described below. That is, the side plate 70 is divided into the front member 21 as a fixed member, which is mounted to the draft device 7 at a fixed position, and the back member 22 as a movable member, the position of which with respect to the draft device 7 is changeable within a predetermined stroke range. The front member 21 comprises the front roller support portion 78 and the middle roller support portion 76. Furthermore, the back member 22 comprises the third roller support portion 75 and the roller support portion 74. When the back member 22 is positioned at the first end of the stroke range (Figure 4), the preset first pitch P1 is provided between the middle roller 16 on the front member 21 side and the third roller 15 on the back member 22 side. When the back member 22 is positioned at the second end of the stroke range (Figure 6), the preset second pitch P2, which is different from the first pitch P1, is provided between the middle roller 16 on the front member 21 side and the third roller 15 on the back member 22 side.

[0064] With this configuration, the gauge between the middle roller 16 and the third roller 15 can be easily changed by changing the mounting position of the back member 22 between the first end and second end of the stroke range. Furthermore, the first pitch P1 or the second pitch P2 can be accurately provided by positioning the back member 22 at the first end or second end of the stroke range. Thus, the operation of precisely adjusting the position of the back member 22 need not be performed. This also facilitates the gauge changing operation. Furthermore, as shown in Figure 8, the gauge can be adjusted without the need to remove the top rollers 14, 15, 16, 18, held in the side plate 70. Therefore, the effort and time required for the gauge changing operation can be reduced.

[0065] Furthermore, in the side plate 70 according to the present embodiment, the back member 22 comprises the third roller support portion 75 and the back roller support portion 74. The side plate 70 is configured such that moving the back member 22 integrally moves the third

roller support portion 75 and the back roller support portion 74.

[0066] With this configuration, simply moving the back member 22 enables the gauge between the middle roller 16 and the third roller 15 to be easily changed while maintaining the gauge between the third roller 15 and the back roller 14. This allows the efficiency of the gauge changing operation to be improved.

[0067] Furthermore, the side plate according to the present embodiment is configured such that with the front member 21 fixed to the draft device 7, the back member 22 is replaceable with the different back member 22X with the roller support portions arranged at a distance from each other which is different from the distance between the roller support portions of the back member 22.

[0068] With this configuration, to change the gauge between the third roller 15 and the back roller 14, it is only necessary to replace the back member 22 with a different one with the front member 21 remaining fixed to the draft device 7. Furthermore, the back member 22 can be replaced with a different one with the front roller 18 and the middle roller 16 held on the front member 21 side. Consequently, the gauge changing operation can be efficiently performed. Moreover, the gauge can be changed to any of various values simply by moving and replacing the back member with a different one with the front member 21 remaining unchanged. This enables a reduction in the material costs of the side plate 70 and in manufacturing costs such as the production costs of die assembly.

[0069] Furthermore, in the present embodiment, the back member 22 comprises the abutting surface on the abutting portion 62. The abutting surface contacts with the front member 21 as shown in Figure 4 to position the back member 22 at the appropriate end of the stroke range.

[0070] Thus, the first pitch P1 can be reproducibly obtained using the simple configuration.

[0071] Furthermore, in the present embodiment, the slot portion 61 is formed in the back member 22, and the end of the slot portion 61 is used to position the back member 22 at the appropriate end of the stroke range as shown in Figures 6 and 7.

[0072] Thus, the second pitch P2 can be reproducibly obtained using the simple configuration.

[0073] Furthermore, in the present embodiment, the back member 22 comprises the notch portion 63 as a slot having one open end, and the back member 22 is mounted to the cradle 20 with the shaft portion of the screw 93 inserted through the notch portion 63.

[0074] With this configuration, to be replaced with a different one, the back member 22 can be removed from the draft device 7 without the screw 93 remaining threadably inserted into the draft device 9. Consequently, the operation of attaching/removing the screw 93 can be omitted, facilitating the operation of replacing the back member 22 with a different one.

[0075] Furthermore, in the present embodiment, the front member 21 comprises the reference line 64, and

the back member 22 comprises the two gauge lines 65, 67.

[0076] As shown in Figures 4 and 6, when the back member 22 is positioned at one of the opposite ends of the stroke range, the reference line 64 aligns with one of the two gauge lines 65, 67.

[0077] With this configuration, reading the reference line 64 and the gauge lines 65, 67 makes it possible to easily determine whether or not the back member 22 is reliably positioned at the appropriate end of the stroke end.

[0078] Furthermore, in the present embodiment, in the back member 22, the display portions 66, 68 are provided close to the respective gauge lines 65, 67, and the first pitch P1 and the second pitch P2 are displayed in the display portions 66, 68 as numbers.

[0079] This configuration makes it possible to easily determine the gauge between the middle roller 16 and the third roller 15.

[0080] The preferred embodiment of the present invention has been described above. However, the present invention can be varied, for example, as described below.

[0081] The present invention is not limited to the case where the back member 22 is mounted directly to the draft device 7. For example, the back member 22 can be mounted to the front member 21 fixed to the draft device 7 so that the back member 22 is movable within the predetermined stroke range.

[0082] The back member 22 according to the present embodiment is configured to be positioned by the appropriate end of the penetrating slot portion 61. However, the present invention is not limited to this. The back member 22 can be positioned by, for example, forming a non-penetrating recess in a surface of the back member 22 which faces the draft device 7, and inserting a pin projecting from the draft device into the groove so that the pin abuts against an appropriate end of the groove.

[0083] Alternatively, the back member 22 can be positioned by inserting a pin projecting from the back member 22 into a slot or groove formed in the front member 21 so that the pin comes into contact with an appropriate end of the slot or groove.

[0084] Instead of the linear reference line 64 and gauge lines 65, 67, for example, small circular or triangular marks can be installed as the reference display portion and position display portion.

[0085] The side plate 70 according to the above-described embodiment is applicable not only to the four-line type draft device but also to a five-line type draft device or a draft device based on any other scheme.

[0086] While the present invention has been described with respect to preferred embodiments thereof, it will be apparent to those skilled in the art that the disclosed invention may be modified in numerous ways and may assume many embodiments other than those specifically set out and described above. Accordingly, the appended claims cover the scope of the invention.

Claims

1. A side plate (70) used to position a plurality of top draft rollers (14, 15, 16, 18) associated with bottom draft rollers (24, 25, 26, 28) in a draft device (7) comprising
5 a fixed roller support member (21) fixed to the draft device (7), and
a moveable roller support member (22), the position of which is variable within a predetermined stroke with respect to the draft device (7),
10 **characterized in that**
the moveable roller support member (22) comprises a plurality of roller support portions (74, 75) so that when the moveable roller support member (22) is positioned at a first or second end of the stroke a preset first or second pitch is provided between the draft rollers (14, 15, 16, 18) on the fixed and the moveable roller support member (21, 22).
2. The side plate (70) according to claim 1,
characterized in that
the movable roller support member (22) is replaceable with another movable roller support member having roller support portions arranged at a different distance.
3. The side plate (70) according to claim 1 or 2,
characterized in that
the movable roller support member (22) has an abutting portion (62) that contacts the fixed roller support portion (21) when the movable roller support portion (22) is at the first end of the stroke.
4. The side plate (70) according to one of the claims 1 to 3,
characterized in that
a slot (61) is formed in at least the fixed roller support member (21) or the movable roller support member (22), and an end of the slot is used to position the movable roller support member (22) at the second end of the stroke.
5. The side plate (70) according to one of the claims 1 to 4,
characterized in that
the movable roller support member (22) comprises a slot (63) having an open end, and the movable roller support member (22) is mounted to the draft device (7) with a shaft portion of a mounting member (93) inserted through the slot.
6. The side plate (70) according to one of the claims 1 to 5,
characterized in that
the fixed roller support member (21) comprises a reference display line (64), the moveable roller support member (22) comprises two position display lines

(65, 67), and the reference display line aligns with one of the two position display lines when the moveable roller support member is positioned at one end of the stroke.

7. A draft device (7) comprising the side plate (70) according to one of the claims 1 to 6.
8. A textile machine comprising a draft device (7) according to claim 7.

Patentansprüche

1. Seitenplatte (70) zur Positionierung mehrerer oberer Streckrollen (14, 15, 16, 18), die unteren Streckrollen (24, 25, 26, 28) in einem Streckwerk (7) zugeordnet sind, bestehend aus
15 einem stationären Rollenstützelement (21), das am Streckwerk (7) befestigt ist, und
20 einem verstellbaren Rollenstützelement (22), dessen Position innerhalb eines bestimmten Hubs bezüglich des Streckwerks (7) variabel ist,
dadurch gekennzeichnet, dass
das verstellbare Rollenstützelement (22) mehrere Rollenstützabschnitte (74, 75) hat, so dass, wenn das verstellbare Rollenstützelement (22) am ersten oder zweiten Hubende positioniert ist, ein erster oder zweiter Abstand zwischen den Streckrollen (14, 15, 16, 18) am stationären und am verstellbaren Rollenstützelement (21, 22) eingestellt wird.
2. Seitenplatte (70) nach Anspruch 1,
dadurch gekennzeichnet, dass
das verstellbare Rollenstützelement (22) gegen ein anderes Rollenstützelement, das Rollenstützabschnitte hat, die in einem unterschiedlichen Abstand angeordnet sind, auswechselbar ist.
3. Seitenplatte (70) nach Anspruch 1 oder 2,
dadurch gekennzeichnet, dass
das verstellbare Rollenstützelement (22) einen Anschlagabschnitt (62) hat, der den stationären Rollenstützabschnitt (21) kontaktiert, wenn der verstellbare Rollenstützabschnitt (22) am ersten Hubende ist.
4. Seitenplatte (70) nach einem der Ansprüche 1 bis 3,
dadurch gekennzeichnet, dass
ein Schlitz (61) wenigstens im stationären Rollenstützelement (21) oder dem verstellbaren Rollenstützelement (22) gebildet ist, und ein Ende des Schlitzes zur Positionierung des verstellbaren Rollenstützelements (22) am zweiten Hubende dient.
5. Seitenplatte (70) nach einem der Ansprüche 1 bis 4,
dadurch gekennzeichnet, dass
das verstellbare Rollenstützelement (22) einen

Schlitz (63) mit einem offenen Ende hat, und das verstellbare Rollenstützelement (22) am Streckwerk (7) befestigt ist, wobei ein Schaftabschnitt eines Befestigungselements (93) durch den Schlitz eingesetzt ist.

6. Seitenplatte (70) nach einem der Ansprüche 1 bis 5, **dadurch gekennzeichnet, dass** das stationäre Rollenstützelement (21) eine Bezugsanzeigelinie (64) hat, das verstellbare Rollenstützelement (22) zwei Positionsanzeigelinien (65, 67) hat, und die Bezugsanzeigelinie mit einer der beiden Positionsanzeigelinien übereinstimmt, wenn das verstellbare Rollenstützelement am einen Hubende angeordnet ist.
7. Streckwerk (7) mit der Seitenplatte (70) nach einem der Ansprüche 1 bis 6.
8. Textilmaschine mit einem Streckwerk (7) nach Anspruch 7.

Revendications

1. Plaque latérale (70) servant à positionner une pluralité de cylindres d'étirage supérieurs (14, 15, 16, 18) associés à des cylindres d'étirage inférieurs (24, 25, 26, 28) dans un banc d'étirage (7) comprenant un élément de support de cylindre stationnaire (21), fixé au banc d'étirage (7), et un élément de support de cylindre mobile (22), dont la position est variable à l'intérieur d'une course prédéterminée par rapport au banc d'étirage (7), **caractérisée en ce que** l'élément de support de cylindre mobile (22) comprend une pluralité de portions de support de cylindre (74, 75), de sorte qu'un premier ou un second pas pré réglé est pourvu entre les cylindres d'étirage (14, 15, 16, 18) sur les éléments de support de cylindre stationnaire et mobile (21, 22) lorsque l'élément de support de cylindre mobile (22) est positionné à une première ou une seconde fin de course.
2. Plaque latérale (70) suivant la revendication 1, **caractérisée en ce que** l'élément de support de cylindre mobile (22) est échangeable contre un autre élément de support de cylindre mobile, dont les portions de support de cylindre sont disposées à une distance différente.
3. Plaque latérale (70) suivant la revendication 1 ou 2, **caractérisée en ce que** l'élément de support de cylindre mobile (22) présente une portion aboutissante (62) qui est en contact avec la portion de support de cylindre stationnaire (21) lorsque la portion de support de cylindre mobile (22) se trouve à la première fin de course.

4. Plaque latérale (70) suivant une des revendications 1 à 3, **caractérisée en ce qu'**une fente (61) est formée au moins dans l'élément de support de cylindre stationnaire (21) ou dans l'élément de support de cylindre mobile (22) et **en ce qu'**une extrémité de la fente sert à positionner l'élément de support de cylindre mobile (22) à la seconde fin de course.
5. Plaque latérale (70) suivant une des revendications 1 à 4, **caractérisée en ce que** l'élément de support de cylindre mobile (22) comprend une fente (63) ayant une extrémité ouverte et **en ce qu'**il est monté sur un banc d'étirage (7) avec une portion d'arbre d'un élément de montage (93) inséré à travers la fente.
6. Plaque latérale (70) suivant une des revendications 1 à 5, **caractérisée en ce que** l'élément de support de cylindre stationnaire (21) comprend une ligne de repérage de référence (64), **en ce que** l'élément de support de cylindre mobile (22) comprend deux lignes de repérage de position (65, 67) et **en ce que** la ligne de repérage de référence est alignée sur une des deux lignes de repérage de position, lorsque l'élément de support de cylindre mobile est positionné à une fin de course.
7. Banc d'étirage (7) comprenant la plaque latérale (70) suivant une des revendications 1 à 6.
8. Machine textile comprenant un banc d'étirage (7) suivant la revendication 7.

FIGURE 2

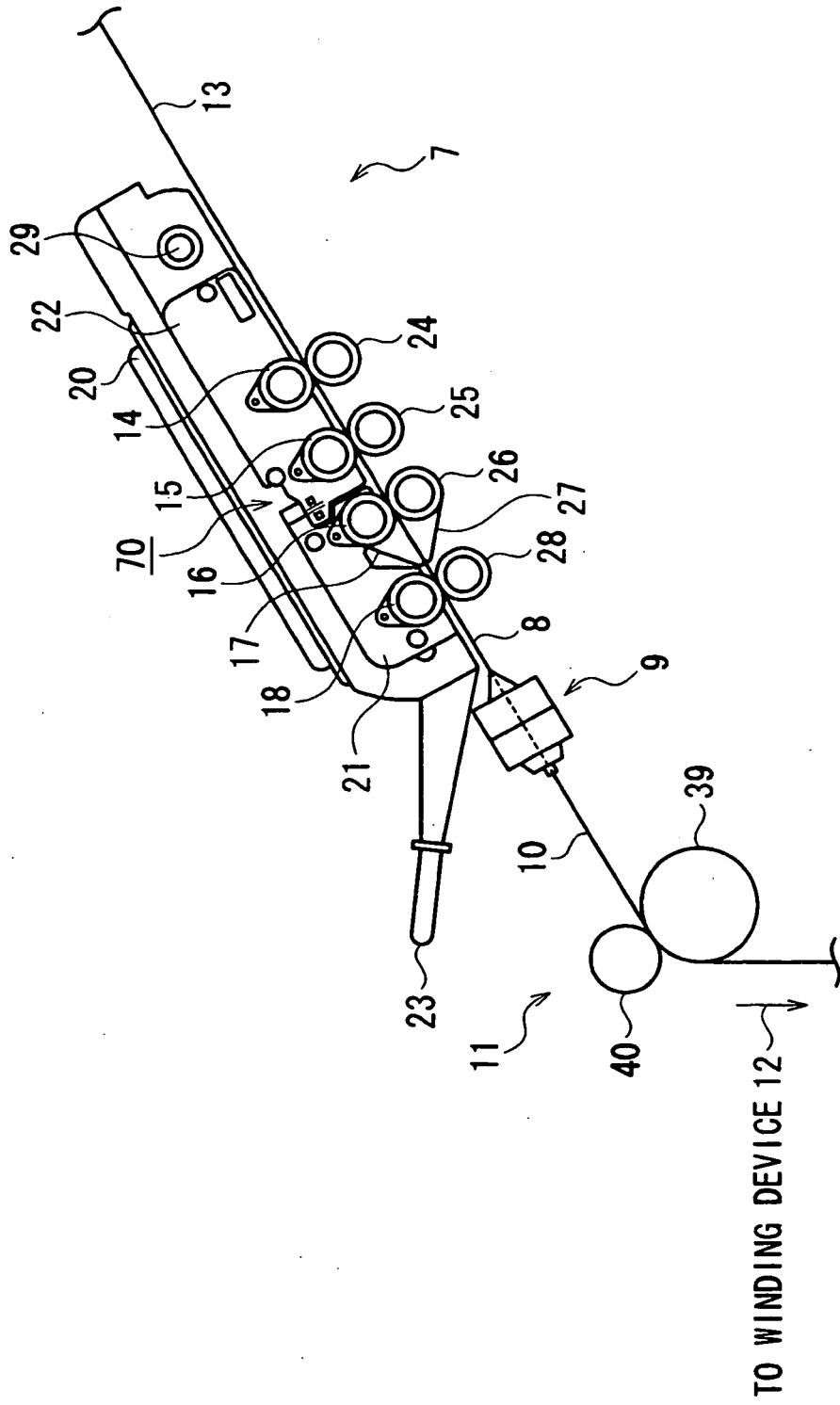

FIGURE 3

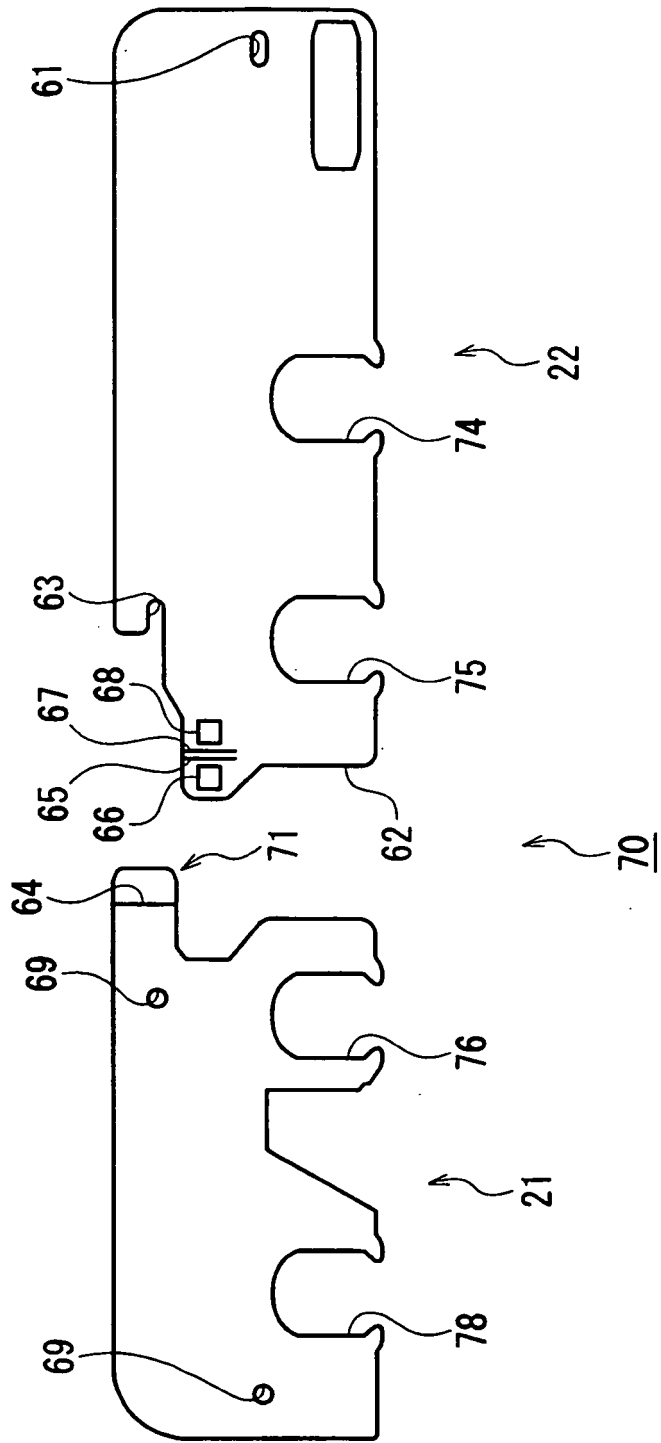

FIGURE 4

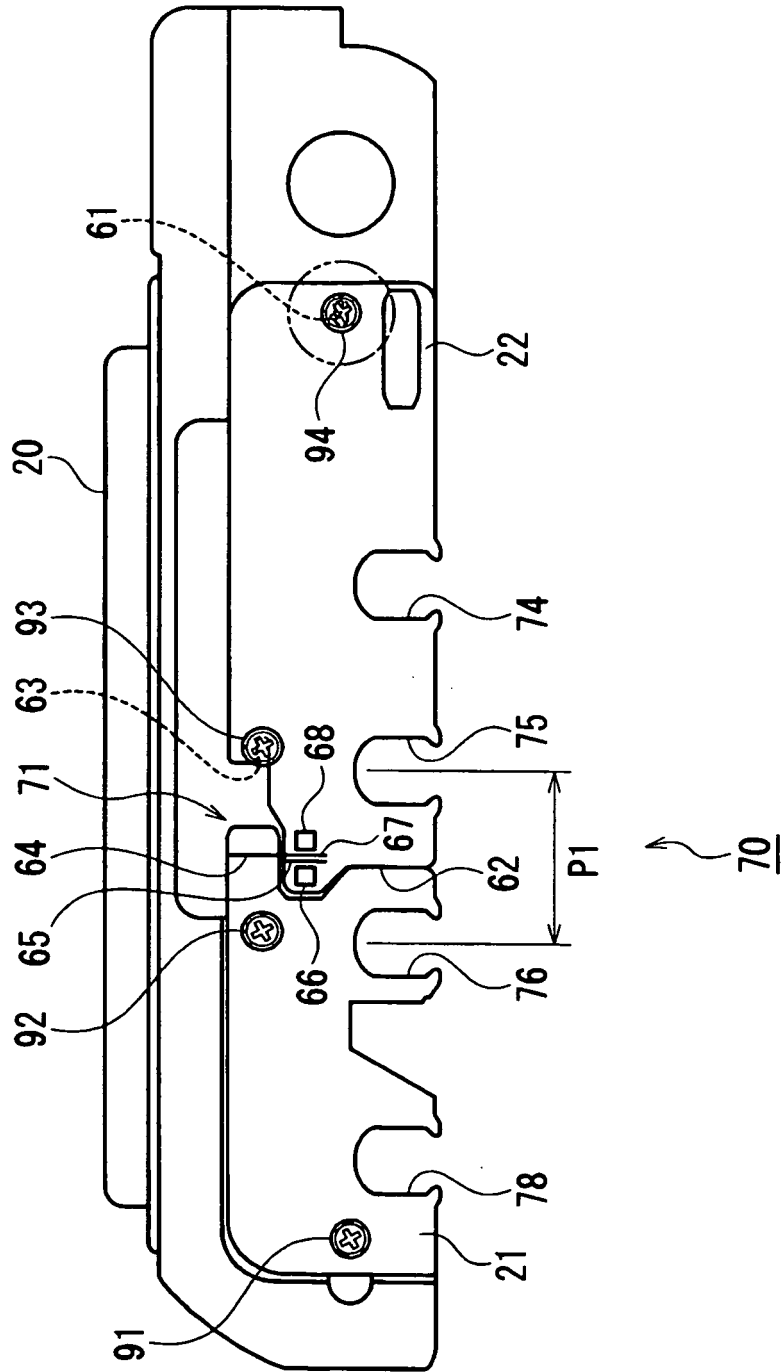

FIGURE 5

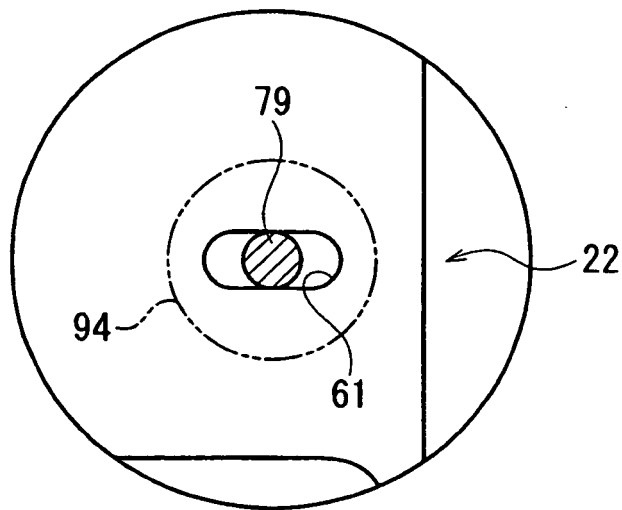

FIGURE 6

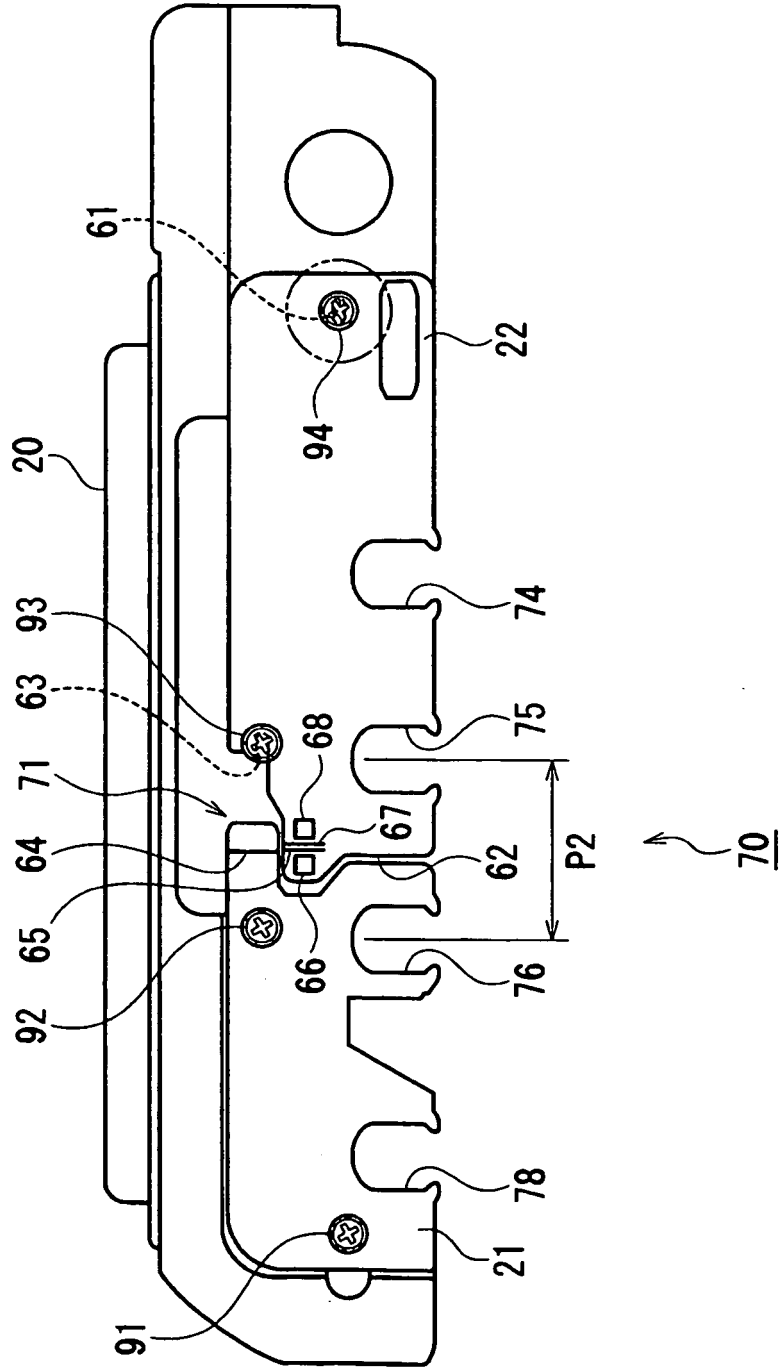

FIGURE 7

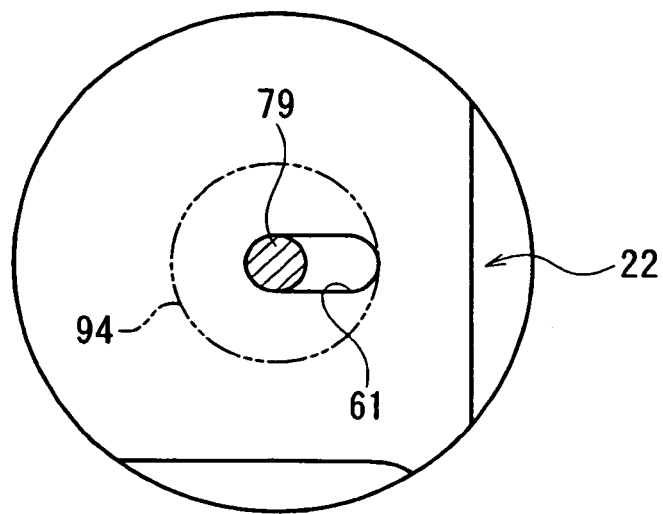

FIGURE 8

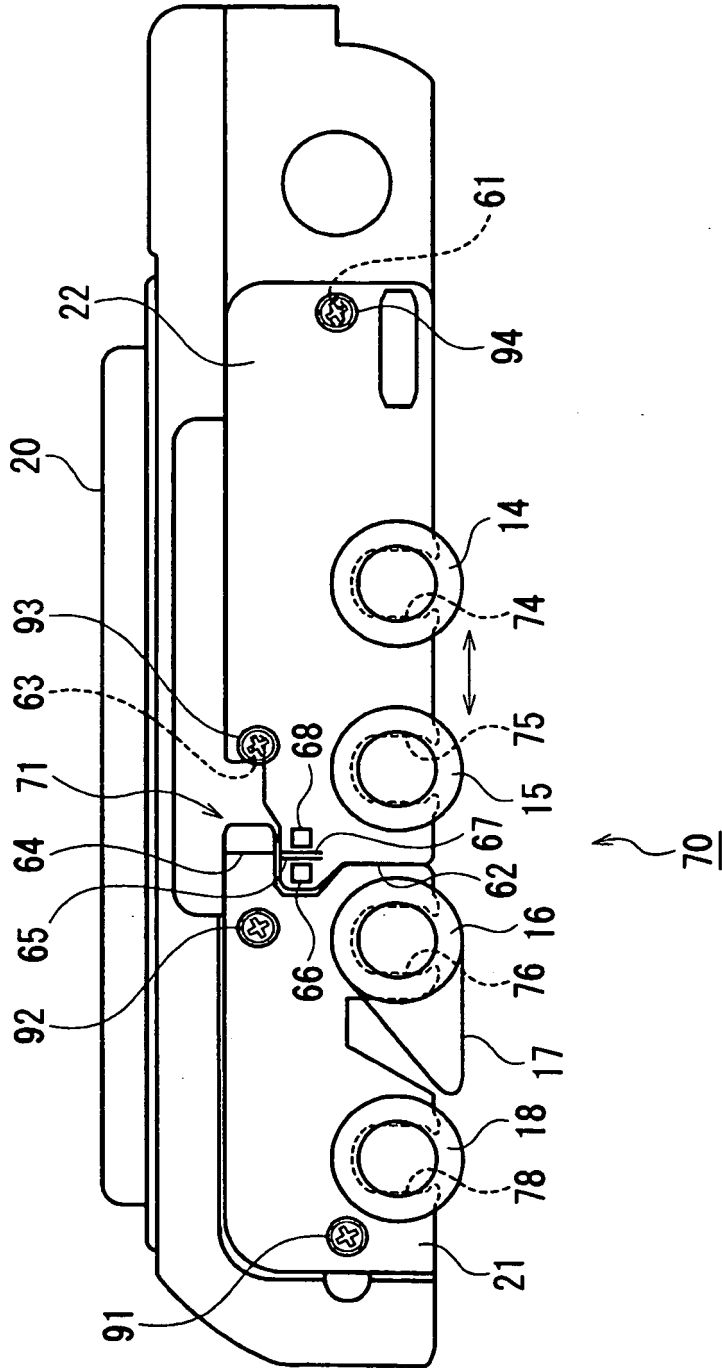

FIGURE 9

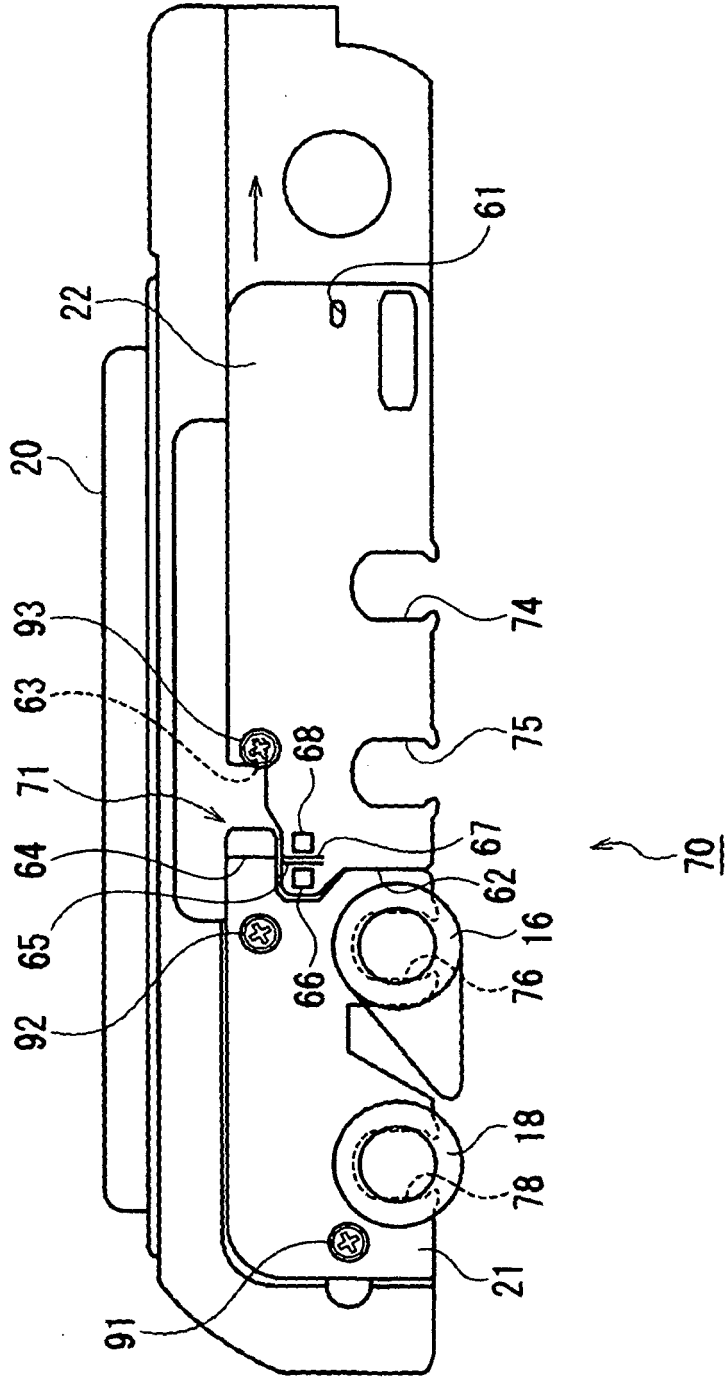
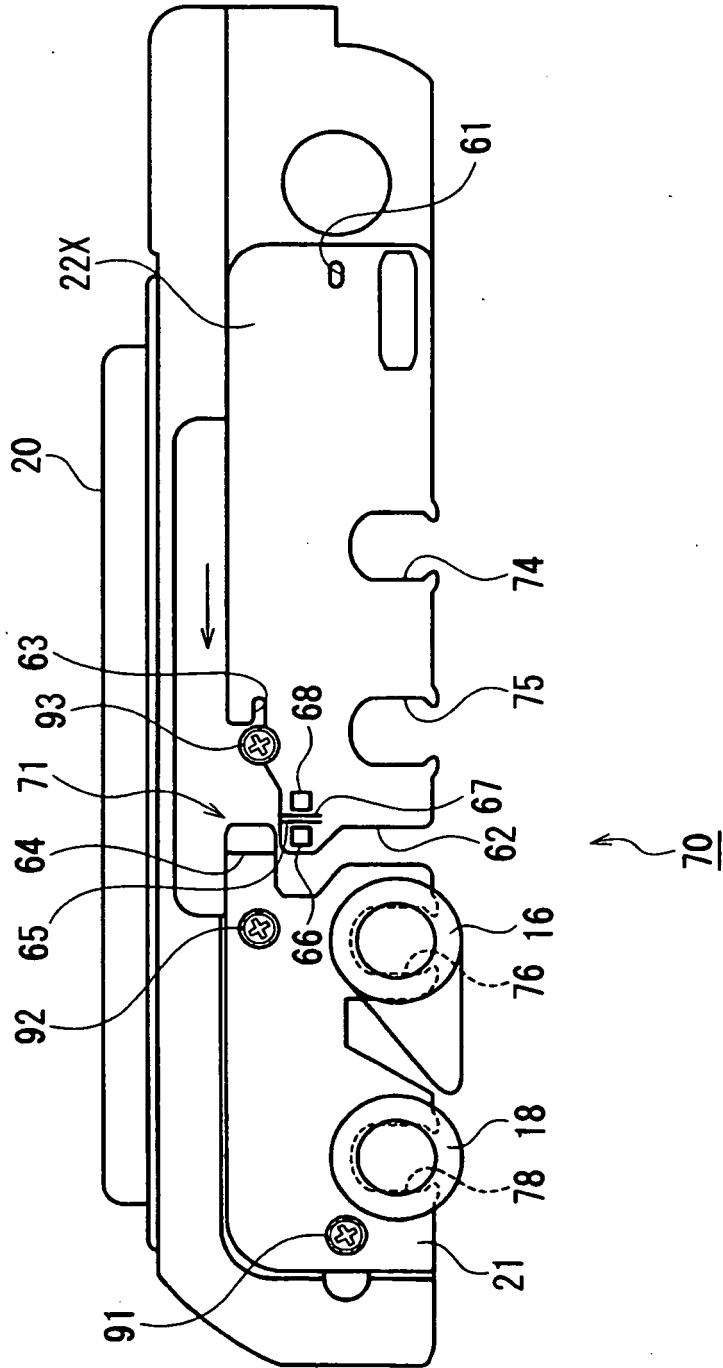

FIGURE 10



REFERENCES CITED IN THE DESCRIPTION

This list of references cited by the applicant is for the reader's convenience only. It does not form part of the European patent document. Even though great care has been taken in compiling the references, errors or omissions cannot be excluded and the EPO disclaims all liability in this regard.

Patent documents cited in the description

- JP 4123268 A [0003] [0004]
- DE 4318025 A [0005]