

# A. Leland, Cutting Metal

N<sup>o</sup> 53,228.

Patented Mar. 13, 1866.

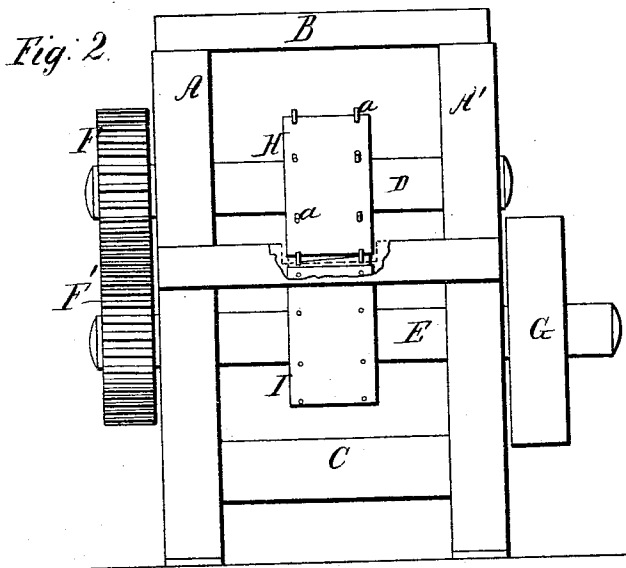
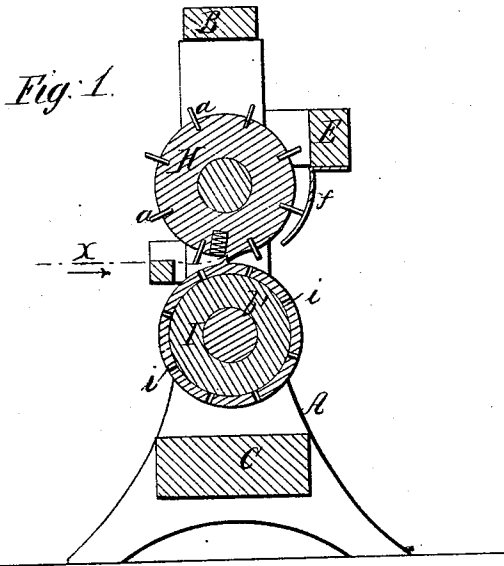
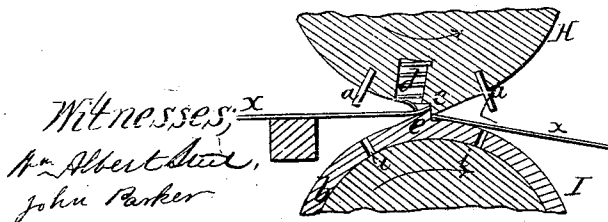

Fig. 3.



Inventor;  
A. Leland  
By his Attorney  
J. H. Rowson

# UNITED STATES PATENT OFFICE.

AMOS LELAND, OF PHILADELPHIA, PENNSYLVANIA, ASSIGNOR TO HIMSELF AND ALEXANDER P. COLESBERRY, OF SAME PLACE.

## MACHINE FOR PERFORATING METAL BANDS.

Specification forming part of Letters Patent No. 53,228, dated March 13, 1866.

*To all whom it may concern:*

Be it known that I, AMOS LELAND, of Philadelphia, Pennsylvania, have invented an Improved Machine for Perforating Metallic Bands, &c.; and I do hereby declare the following to be a full, clear, and exact description of the same, reference being had to the accompanying drawings, and to the letters of reference marked thereon.

My invention consists in two cylinders, from one of which project pins into recesses in the adjacent cylinder, and on each of which is a rib with a cutting-edge, so that bands of metal passed between the two will be perforated and cut into strips of the length desired; and my invention further consists of certain springs combined with one of the cylinders, so that after the band is cut it will be retained in its position.

In order to enable others skilled in the art to make and use my invention, I will now proceed to describe its construction and operation.

On reference to the accompanying drawings, which form a part of this specification, Figure 1 is a sectional elevation of my improved machine for perforating metal bands, &c.; Fig. 2, a front elevation, and Fig. 3 a detached sectional view drawn to an enlarged scale.

A and A' are the side frames of the machine, which are connected by the cross-pieces B and C, and in which turn the shafts D and E.

On the end of the shaft D is a cog-wheel, F, which gears into a similar cog-wheel, F', on the end of the lower shaft, E, and on the opposite end of this shaft is a band-pulley, G.

On the center of the shaft D is secured a cylinder, H, from which, near each edge of the same, project a series of pins, *a*, and on the shaft E is a cylinder, I, each side of which is cut away so as to leave an annular ledge or flange, *b*, in which are a series of openings, *i*, the said openings being so situated that the ends of the pins *a* shall project into the same as the cylinders revolve.

Across the face of the cylinder H extends a projection or rib, *e*, which has a cutting-edge, and which engages with a similar rib, *e*, on the cylinder I, as shown in Fig. 3.

To a bracket, E, at one side of the cylinder I, is secured a curved plate, *f*, for a purpose described hereinafter.

Near each edge of the cylinder H, and near

the rib *e*, is a recess, in which fits a coiled spring *d*, the end of the latter projecting beyond the face of the cylinder, for a purpose described hereinafter.

When a strip or band of metal is to be perforated a rotary motion in the direction of its arrow, Fig. 3, is imparted to each cylinder H I, and the band is introduced between the cylinders, near either edge of the same, so as to be carried forward in the direction of the arrow, Fig. 1, the pins *a* being brought successively against the band, penetrating the latter and forming the openings required, the band adhering to the pins until it is brought against the lower edge of the plate *f*, which strips it from the same. As the cylinders revolve and the ribs *e e* are brought opposite each other the band is severed by the cutting-edges of these ribs, the end of the band being, however, retained in its place and prevented from slipping by the pressure upon it of the end of the spring *d*.

If desirable, two bands may be perforated at the same time, one being passed between the cylinders near one edge and the other at the opposite edge of the same.

It will be apparent that when it is desirable to cut the band into strips of shorter length than that of the diameter of the cylinders additional cutting-ribs may be secured to the same.

The strips thus perforated may be united together at the ends, so as to form hoops for casks, or they may be used for securing fruit-boxes, dry-goods boxes, and for other similar purposes.

I claim as my invention and desire to secure by Letters Patent—

1. The cylinder H, with its pins *a* and rib *e*, and the cylinder I, with its flanges *b*, openings *i*, and rib *e*, constructed and operating in respect to each other as and for the purpose specified.

2. The combination, with the cylinder H, of the spring *d*, for retaining the ends of the bands, substantially as described.

In testimony whereof I have signed my name to this specification in the presence of two subscribing witnesses.

AMOS LELAND.

Witnesses:

CHARLES E. FOSTER,  
JOHN WHITE.