

(No Model.)

2 Sheets—Sheet 1.

M. READY.
HEATER.

No. 524,399.

Patented Aug. 14, 1894.

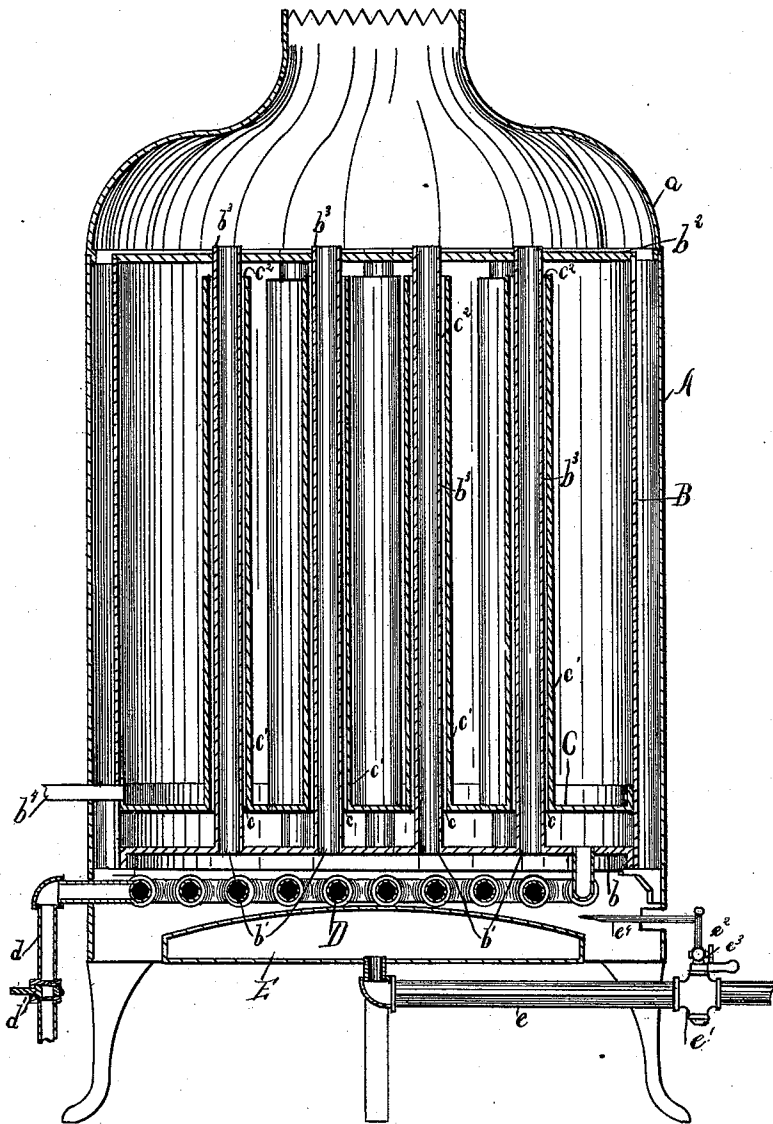

Fig. 1.

WITNESSES:
W. H. Wood.
Benjamin Bloch.

INVENTOR
Maurice Ready,
BY
Geo. B. Farnham,
His ATTORNEY.

M. READY.
HEATER.

No. 524,399.

Patented Aug. 14, 1894.

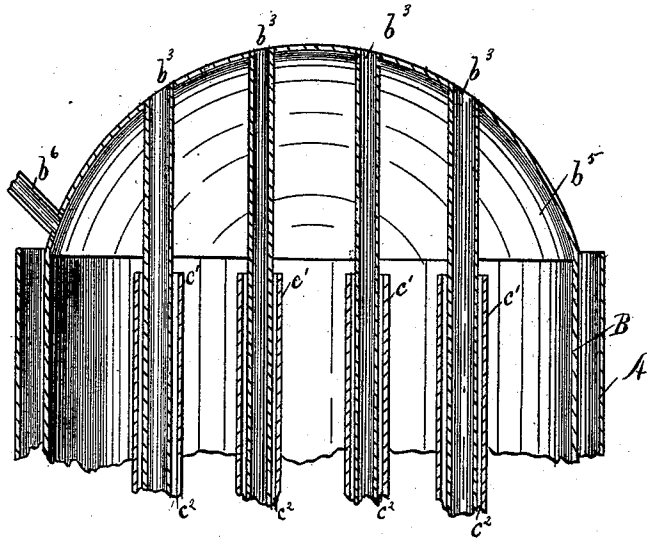

FIG. 2.

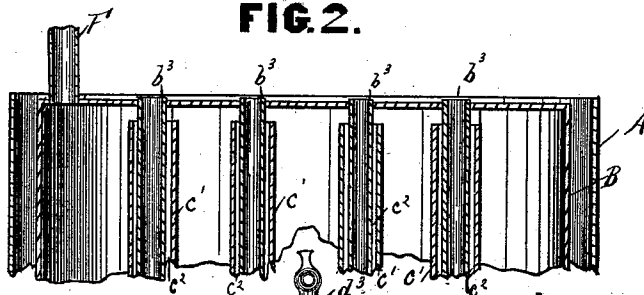

FIG. 3.

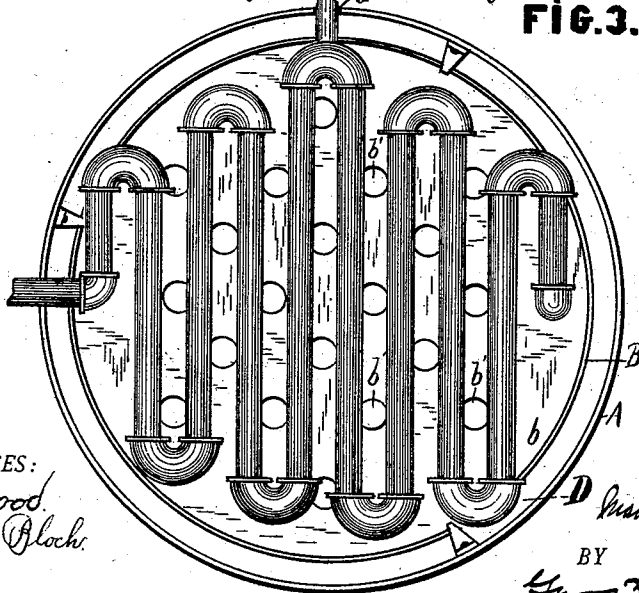

FIG. 4.

WITNESSES:
E. K. Hood
Benjamin Block

INVENTOR
M. Ready
 BY
Geo. B. Parkinson
 His ATTORNEY.

UNITED STATES PATENT OFFICE.

MAURICE READY, OF DAYTON, OHIO.

HEATER.

SPECIFICATION forming part of Letters Patent No. 524,399, dated August 14, 1894.

Application filed May 14, 1894. Serial No. 511,154. (No model.)

To all whom it may concern:

Be it known that I, MAURICE READY, a citizen of the United States, residing at Dayton, in the county of Montgomery and State of Ohio, have invented a certain new and useful Improvement in Heaters, of which the following is a specification.

My invention is especially adapted for bath rooms and other places where temporary heating is desirable without the expenditure necessary for continuous heating, but it is applicable to any class of heaters for the treatment of fluids.

The object of my invention is to provide a heater in which a great fluid surface is exposed to the heat and in which the heating may be rapidly and economically accomplished.

In the drawings, Figure 1 is a vertical section of my apparatus; Fig. 2 a partial section of a modification of the same; Fig. 3 a partial section of another modification; Fig. 4 a bottom plan of the heater.

A represents a casing or jacket, preferably of sheet metal, provided with a hood, *a*.

B is an inner casing or reservoir having a bottom, *b* with openings, *b'*, therein and steam tight covering, *b²*. Extending vertically through the reservoir, B, from the apertures in the bottom, *b*, are flue tubes *b³*, which extend through the covering, *b²*, and form a steam tight joint therewith. The reservoir has a false bottom, C, provided with openings, *c*, surrounding the flue tubes and larger than their outer diameter. Extending vertically upward from the openings in the false bottom are pipes, *c'*, which surround the flue tubes and terminate a short distance from the covering, *b²*. A communication between the divided portions of the reservoir is thus obtained through the space, *c²*, surrounding the flue tubes.

Beneath the reservoir, is a coil, D, having its intake through a pipe, *d*, provided with a regulating valve, *d'*, and discharging into the lower portion of the reservoir, between the bottom, *b*, and the false bottom. If water or other fluid is allowed to enter through the valve, *d'*, the receptacle between the two bottoms will first be filled, the fluid will then

rise in the spaces, *c²*, surrounding the flue tubes and fall into the portion of the reservoir above the false bottom, whence it may be drawn off through a pipe, *b⁴*. By this arrangement, if heat is applied below the coil, D, it will rise through the flue tubes, *b³*, and between the jacket and the reservoir, and into the hood, *a*, through which the products of combustion pass off. The water or fluid to be heated is subjected to heat in the coil, D; between the two bottoms; in the space *c²*, and in the remaining portion of the reservoir B; and by allowing cold water to flow into the coil, D, it can be drawn off at, *b⁴*, or allowed to pass into a hot water pipe at F, heated to a high temperature, and a continuous flow can be maintained with the same results.

In order to draw the water out of the coil and the space between the two bottoms an outlet, *d²*, having a stop cock is provided.

In Fig. 2 I have shown a modification of my invention which adapts the heater to the steam heating system for buildings and the like. The cover, *b²*, is curved to form a steam dome, *b⁵*, having an outlet, *b⁶*. The heating process is the same as before, but the dome furnishes a space for collecting the steam.

I have shown a preferred form of heating apparatus consisting of a gas burner, E, provided with an inlet, *e*, and a cut off valve, *e'*, therein.

For lighting the gas I provide mechanism as follows: Leading from the movable portion of the valve is a tube, *e²*, having a stop cock, *e³*, and adapted to swing as the valve is turned. In the form shown the tube has a vertical portion and a horizontal portion, *e⁴*, adapted to swing to a point adjacent to the jets of the burner. A small channel through the valve seat leads from the supply side of the pipe to the pipe, *e²*. When the valve, *e'*, is closed, the valve, *e³*, is opened and the gas lights at the end of the tube *e⁴*; the valve, *e'*, may then be turned and a supply of gas let into the burner. As the valve is turned, the lighting mechanism moves with it and brings the end of the tube, *e⁴*, over the burner and ignites the gas.

I claim as my invention—

1. The combination in a heater, of a casing; 100

a reservoir within the casing; flue tubes extending through the reservoir; a false bottom in the reservoir; pipes encircling the flue tubes and extending from the false bottom to a joint below the top of the reservoir, and an outlet for the reservoir, substantially as and for the purpose specified.

2. The combination, in a heater, of a casing; a reservoir within the casing; flue tubes extending through the reservoir a false bottom

in the reservoir; pipes encircling the flue tubes and extending from the false bottom to a joint below the top of the reservoir, and an outlet for the reservoir, a burner; a coil of pipe, adjacent to the burner, and leading into the space beneath the false bottom.

MAURICE READY.

Witnesses:

WM. G. FRIZELL,
HARRY F. NOLAN.