

E. E. YAXLEY.
TIME RECORDER.

APPLICATION FILED FEB. 20, 1911.

Patented July 11, 1911.

3 SHEETS—SHEET 1.

997,353.

Fig. 1.

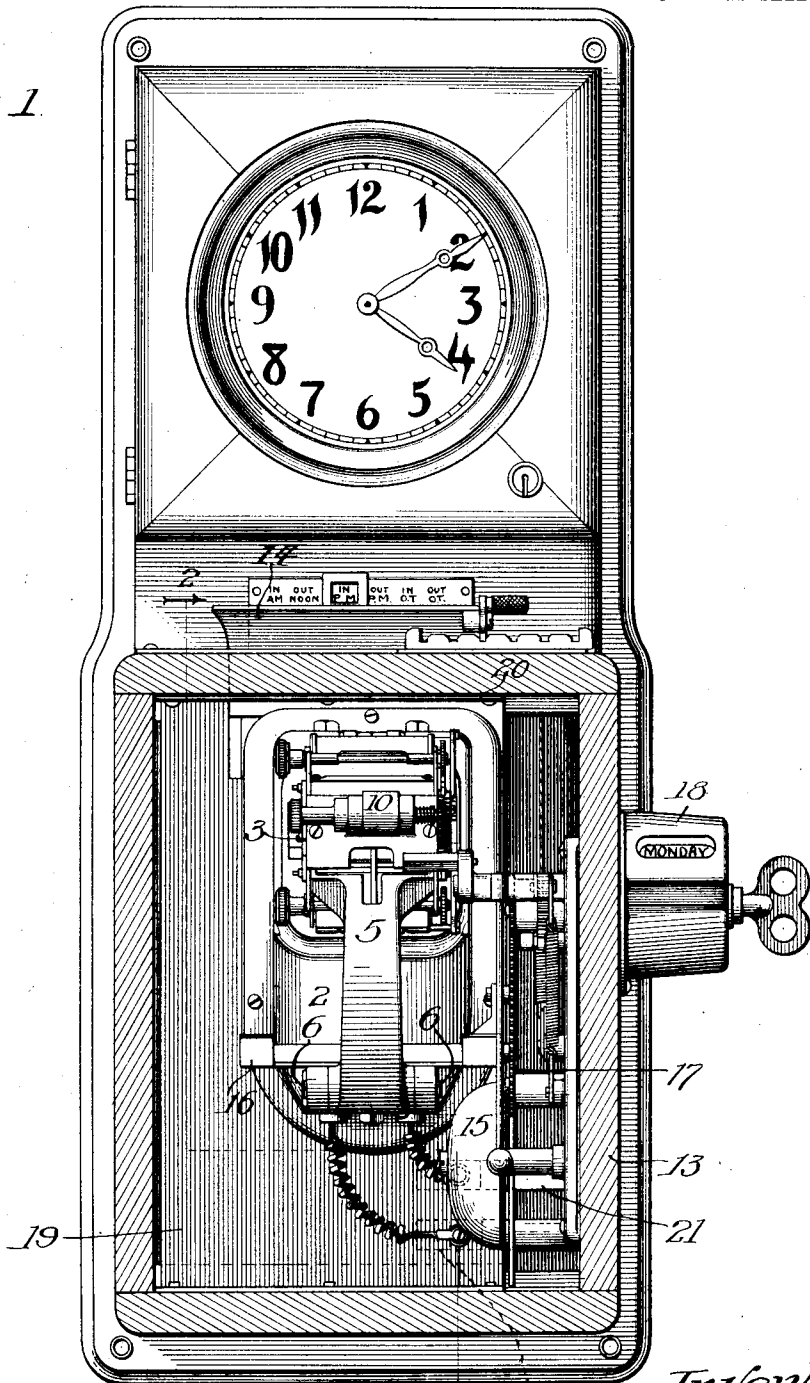

Witnesses:
Ed. Davison
Harold G. Barnett

Inventor:
Ernest E. Yaxley
by G. L. Crofford

E. E. YAXLEY.
TIME RECORDER.

APPLICATION FILED FEB. 20, 1911.

Patented July 11, 1911.

3 SHEETS-SHEET 2.

997,353.

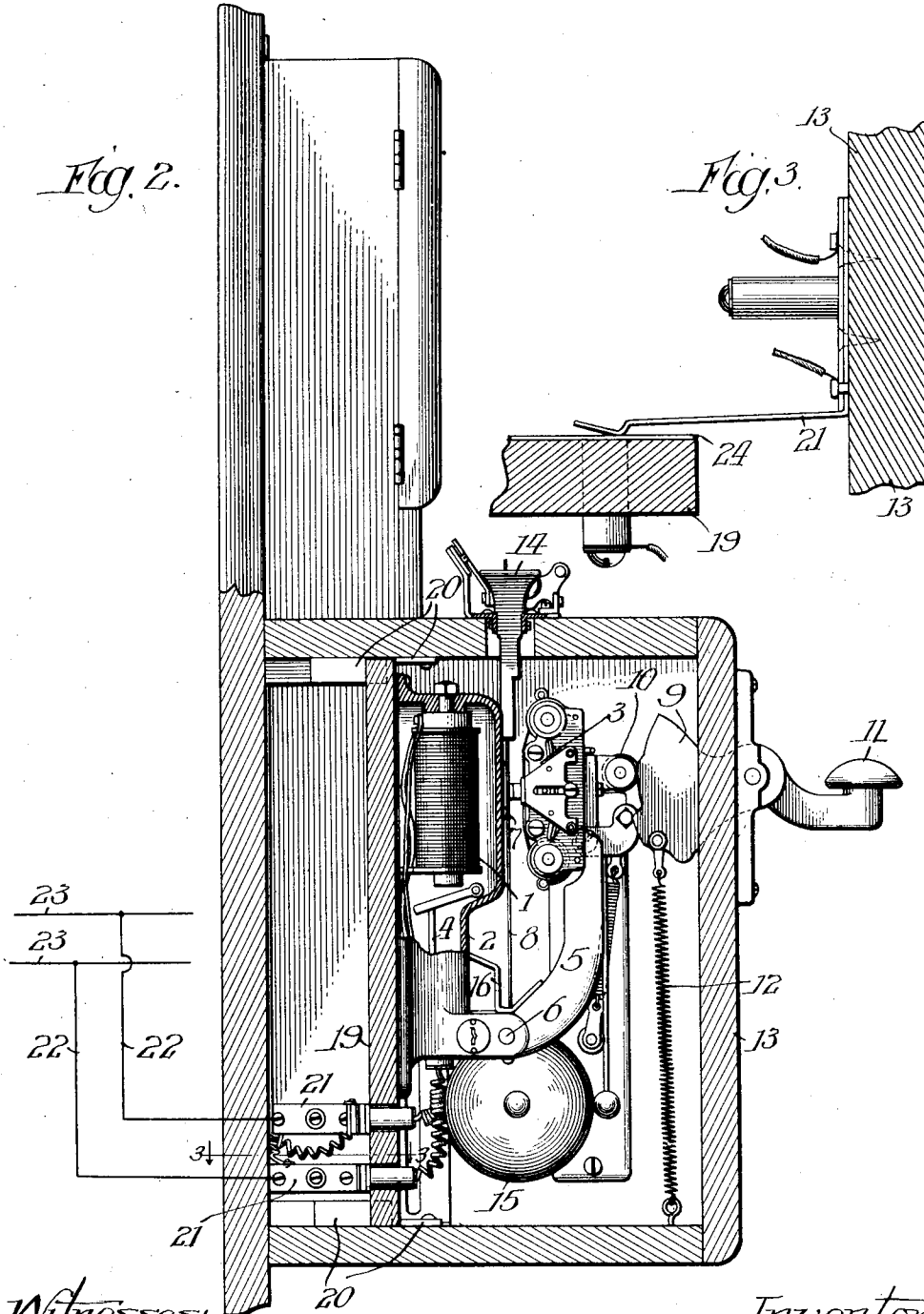

Witnesses:
Geo. Dawson
Harold W. Parrott.

Inventor:
Ernest E. Yaxley.
by *G. L. Cragg* Atty^{ys}

E. E. YAXLEY.
TIME RECORDER.

APPLICATION FILED FEB. 20, 1911.

Patented July 11, 1911.

3 SHEETS—SHEET 3.

997,353.

Fig. 4.

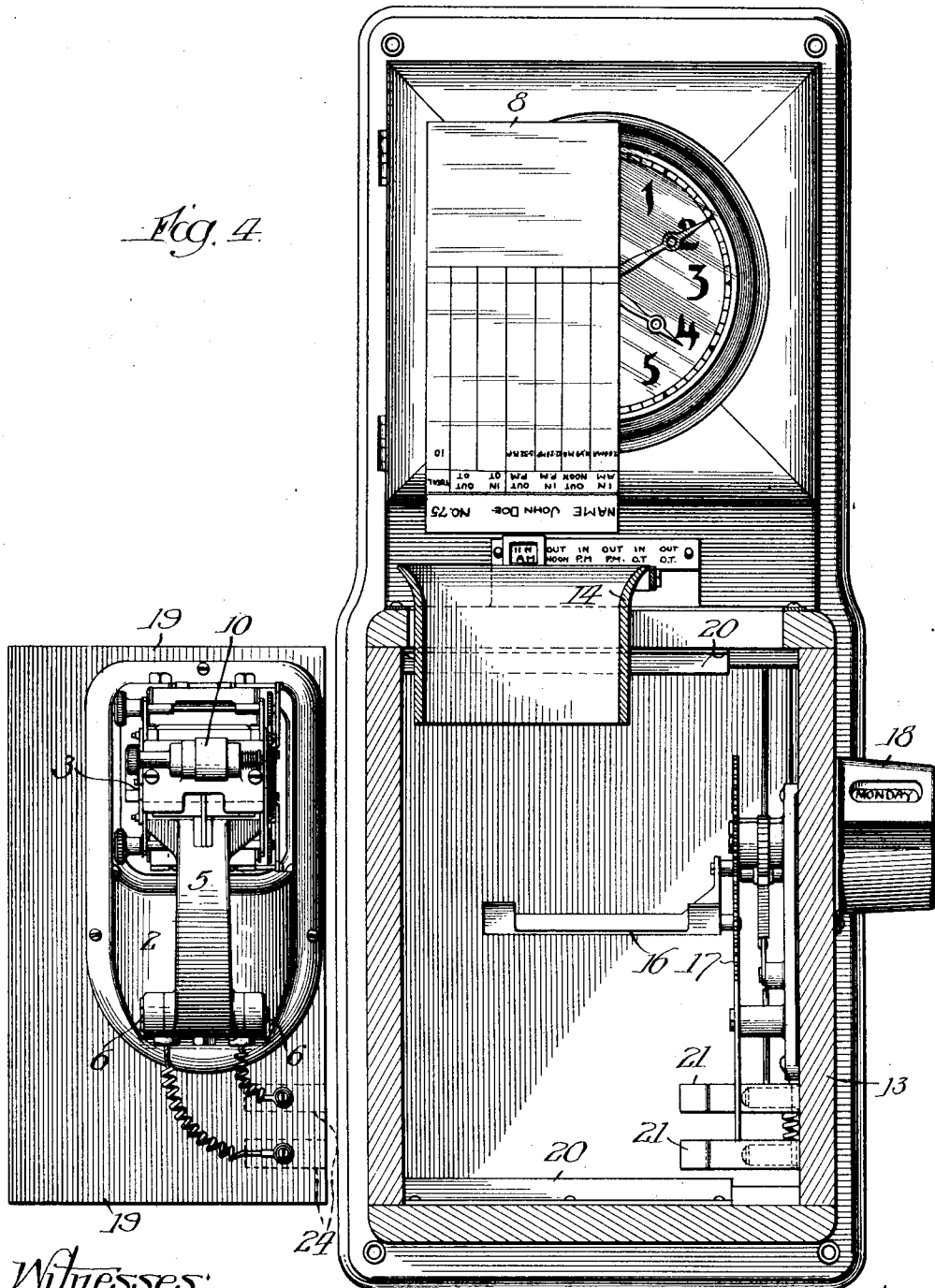

Witnesses:
Ed. Dixon
Harold Barrett

Inventor:
Ernest E. Yaxley.
by E. K. Craig, Atty.

UNITED STATES PATENT OFFICE.

ERNEST E. YAXLEY, OF CHICAGO, ILLINOIS, ASSIGNOR TO MONARCH TELEPHONE MANUFACTURING COMPANY, OF CHICAGO, ILLINOIS, A CORPORATION OF ILLINOIS.

TIME-RECORDER.

997,353.

Specification of Letters Patent. Patented July 11, 1911.

Application filed February 20, 1911. Serial No. 609,696.

To all whom it may concern:

Be it known that I, ERNEST E. YAXLEY, citizen of the United States, residing at Chicago, in the county of Cook and State of Illinois, have invented a certain new and useful Improvement in Time-Recorders, of which the following is a full, clear, concise, and exact description, reference being had to the accompanying drawings, forming a part of this specification.

My invention relates to time recorders of that class in which periodically adjusted time characters are employed.

The mechanism that is directly concerned in adjusting the time characters is comparatively intricate and subject to disorder as a consequence of which time recorders as hitherto devised are thrown out of service when the mechanism that is employed in adjusting time characters is out of order.

It is the object of my invention so to associate the time character adjusting mechanism with the balance of the time recorder that such time character adjusting mechanism may readily be dissociated from the balance of the time recorder and the agency that is employed to operate it and which may readily be replaced by a fresh time character adjusting mechanism whereby the time recorder need never be out of working order so long as the balance thereof is not deranged.

My invention finds one embodiment in a time recorder that includes electrically operated time character adjusting mechanism, and when the invention is so embodied I mount the time character adjusting mechanism upon a support or mounting of its own which may readily be withdrawn from the casing of the time recorder, leaving the balance of the time recording mechanism in position since such balance of the time recording mechanism is not subject to frequent derangement. Separable conductors are included in circuit with the electro-magnetic mechanism that is employed to operate the time character adjusting mechanism, portions of these conductors being provided upon the mounting for the time character adjusting instrument and the complementary portions being mounted upon or within the casing of the time recorder. In

the preferred embodiment of the invention the said mounting carries a pair of plates that constitute terminals of the conductors that extend to said electro-magnetic mechanism while the casing of the time recorder carries spring contacts that constitute terminals of a time circuit, such as a well known secondary clock circuit, and which are engaged with the aforesaid plates when a mounting is inserted in place and are separated from said plates when such a mounting is withdrawn from the time recorder case. I do not limit myself, however, to an electrical association of the time character adjusting mechanism as I desire broadly to claim the separability of the time recorder mechanism and the means, electrical or otherwise, that governs this operation.

I will explain my invention by reference to the accompanying drawings showing the preferred embodiment thereof in the case of an electro-magnetically operated time character adjusting device employed in combination with the balance of a time recording mechanism, and in which drawings—

Figure 1 is a front elevation of a time recorder with the time character adjusting mechanism in position, the front portion of the case of the time recorder mechanism being shown in section to reveal hidden parts; Fig. 2 is a sectional view on line 2 2 of Fig. 1; Fig. 3 is a detail sectional plan view of parts as they appear in Fig. 4; and Fig. 4 is a view similar to Fig. 1 excepting that the time character adjusting mechanism is shown as having been withdrawn from the casing of the time recorder, or parts shown in Fig. 4 may be considered as being in the relative positions they might occupy when the time character adjusting mechanism is in the act of being inserted within the casing of the time recorder.

Like parts are indicated by similar characters of reference throughout the different figures.

The time character adjusting mechanism illustrated is of a well known type and needs no specific description. It includes an electro-magnet 1 that is mounted within an upright base 2 and which serves to adjust or position the time characters that are located at 3 through the intermediation of mecha-

nism partially illustrated at 4. The time characters located at 3 are mounted upon an arm 5 that is pivoted at 6 to the base 2. This mechanism includes a rubber pad 7 in front of which a time record card 8 may be located in proper position in accordance with well known practice, whereupon the time characters 3 may be pressed against the card to print or otherwise place the record upon the card, these time characters being moved toward the pad 7 by means of a cam 9 that works upon a cam roller 10 when the lever 11 is displaced, this lever being shown in an intermediate position in Fig. 2. A spring 12 restores the cam 9 to normal when hand pressure is removed from said lever whereafter the card is released in order that it may be withdrawn from the casing 13 of the time recorder through the chute 14. An alarm device 15 is operated when the lever is in an intermediate position to guard against fraudulent manipulation of the time card 8. The time stamp actuating means 9, 11 and 12; the alarm bell 15; the chute 14; the card gage 16; the card gage adjusting mechanism 17; and the card gage indicating device 18 are all normally permanently mounted upon and within the casing 13 of the time recorder. The time characters and the mechanism (including elements 1 and 4 and other parts which need not be shown or described as they are well understood) for adjusting the same periodically are placed upon a separate mounting 19 which is removably mounted within the casing 13 and is desirably limited to a sliding movement in a plane parallel with the card slot of the chute 14 so that this time character adjusting mechanism may readily be brought into suitable relation with the lower end of the card chute 14, to which end the board 19 is provided with slide guides 20 between and along which the board or mounting 19 is movable. The casing 13 has mounted thereupon two spring contact terminals 21 that are connected by means of conductors 22 with the sides of a secondary clock circuit 23, which circuit constitutes the agency here employed for periodically energizing the electro-magnetic mechanism 1, periodically to adjust the time characters, all as is well understood but to which electrical control of the time characters I do not wish to be limited. The mounting 19 for the time character adjusting mechanism has mounted thereupon two contact plates 24 that are in register each with a spring terminal 21 so that when the mounting 19 is inserted in position the electro-magnetic mechanism 1 is brought into proper association with the sides of the secondary clock circuit 23 and whereby this circuit association with the electro-magnetic mechanism is automatically broken when the time character adjusting mechanism is

withdrawn from the casing, though I do not wish to be limited to the automatic opening and closing of the contacts 21 and 24.

When the time character adjusting mechanism that forms a part of a time recorder gets out of order it may be very quickly withdrawn and replaced by another that is in order so as to reduce to a minimum the time during which the time recorder as a whole is out of working condition.

Having thus described my invention, I claim as new and desire to secure by Letters Patent the following:—

1. A time recorder including time character adjusting mechanism inclosed within a casing and in separable relation with a complementary part of the time recording mechanism, said character adjusting mechanism being provided upon a mounting which is normally in separable relation with the casing of the time recorder that incloses the character adjusting mechanism.

2. A time recorder including time character adjusting mechanism inclosed within a casing and in separable relation with a complementary part of the time recording mechanism, said character adjusting mechanism being provided upon a mounting which is normally in separable relation with the casing of the time recorder that incloses the character adjusting mechanism; and guiding means for directing the movement of the mounting for the time character adjusting mechanism.

3. A time recorder including electro-magnetically operated time character adjusting mechanism inclosed within a casing and in separable relation with a complementary part of the time recording mechanism, said character adjusting mechanism being provided upon a mounting which is normally in separable relation with the casing of the time recorder that incloses the character adjusting mechanism; and contacts carried by the mounting of the time character adjusting mechanism and the casing of the time recorder, whereby the circuit association of the time character adjusting mechanism is automatically broken when this mechanism is withdrawn and is readily established when this mechanism is located in position within the casing.

4. A time recorder including electro-magnetically operated time character adjusting mechanism inclosed within a casing and in separable relation with a complementary part of the time recording mechanism, said character adjusting mechanism being provided upon a mounting which is normally in separable relation with the casing of the time recorder that incloses the character adjusting mechanism; guiding means for directing the movement of the mounting for the time character adjusting mechanism; and contacts carried by the mounting of the time

character adjusting mechanism and the casing of the time recorder, whereby the circuit association of the time character adjusting mechanism is automatically broken when
5 this mechanism is withdrawn and is readily established when this mechanism is located in position within the casing.

In witness whereof, I hereunto subscribe my name this 18th day of February A. D., 1911.

ERNEST E. YAXLEY.

Witnesses:

G. L. CRAGG,
GEO. C. DAVISON.

Copies of this patent may be obtained for five cents each, by addressing the "Commissioner of Patents, Washington, D. C."
