



- (51) **International Patent Classification:**
E21B 17/00 (2006.01) *E21B 41/00* (2006.01)
- (21) **International Application Number:**
PCT/US2019/061031
- (22) **International Filing Date:**
12 November 2019 (12.11.2019)
- (25) **Filing Language:** English
- (26) **Publication Language:** English
- (30) **Priority Data:**
62/758,862 12 November 2018 (12.11.2018) US
- (71) **Applicant: EXXONMOBIL UPSTREAM RESEARCH COMPANY** [US/US]; (EMHC-N1-4A-607), 22777 Springwoods Village Parkway, Spring, TX 77389 (US).
- (72) **Inventors: NARHI, Ward, E.;** 4303 Garden Hills Ln., Kingwood, TX 77345 (US). **BARRY, Michael, D.;** 251 N. Maple Glade Circle, The Woodlands, TX 77382 (US).
- (74) **Agent: JAMES, Ricky, F.** et al.; ExxonMobil Upstream Research Company, (EMHC-N1-4A-607), 22777 Springwoods Village Parkway, Spring, TX 77389 (US).
- (81) **Designated States** (*unless otherwise indicated, for every kind of national protection available*): AE, AG, AL, AM,

AO, AT, AU, AZ, BA, BB, BG, BH, BN, BR, BW, BY, BZ, CA, CH, CL, CN, CO, CR, CU, CZ, DE, DJ, DK, DM, DO, DZ, EC, EE, EG, ES, FI, GB, GD, GE, GH, GM, GT, HN, HR, HU, ID, IL, IN, IR, IS, JO, JP, KE, KG, KH, KN, KP, KR, KW, KZ, LA, LC, LK, LR, LS, LU, LY, MA, MD, ME, MG, MK, MN, MW, MX, MY, MZ, NA, NG, NI, NO, NZ, OM, PA, PE, PG, PH, PL, PT, QA, RO, RS, RU, RW, SA, SC, SD, SE, SG, SK, SL, SM, ST, SV, SY, TH, TJ, TM, TN, TR, TT, TZ, UA, UG, US, UZ, VC, VN, ZA, ZM, ZW.

- (84) **Designated States** (*unless otherwise indicated, for every kind of regional protection available*): ARIPO (BW, GH, GM, KE, LR, LS, MW, MZ, NA, RW, SD, SL, ST, SZ, TZ, UG, ZM, ZW), Eurasian (AM, AZ, BY, KG, KZ, RU, TJ, TM), European (AL, AT, BE, BG, CH, CY, CZ, DE, DK, EE, ES, FI, FR, GB, GR, HR, HU, IE, IS, IT, LT, LU, LV, MC, MK, MT, NL, NO, PL, PT, RO, RS, SE, SI, SK, SM, TR), OAPI (BF, BJ, CF, CG, CI, CM, GA, GN, GQ, GW, KM, ML, MR, NE, SN, TD, TG).

Declarations under Rule 4.17:

- *as to applicant's entitlement to apply for and be granted a patent (Rule 4.17(ii))*
- *as to the applicant's entitlement to claim the priority of the earlier application (Rule 4.17(iii))*

(54) **Title:** TUBULAR BODY CONTAINING COMPRESSIBLE PARTICLES, AND METHOD OF ATTENUATING ANNULAR PRESSURE

(57) **Abstract:** A tubular body (200) for a wellbore. The tubular body (200) comprises an elongated pipe body (220) having a box end (210) and a pin end (214), defining a wall. The tubular body includes a filter screen (230). The filter screen (230) is disposed around an outer diameter of the wall along at least a portion of the elongated body. The filter screen (230) defines a cylindrical body (236) having slots (315A, 315B) there along. A plurality of compressible particles (240) are held within the filter screen. Each of the compressible particles is fabricated to collapse in response to fluid pressure communicated through the slots. A method of mitigating pressure within a trapped annulus (142, 152) is also provided herein. The method includes the use of at least one of the tubular bodies (236) along a casing string.

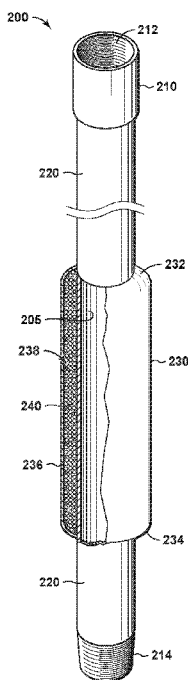

FIG. 2B

WO 2020/102257 A1

Published:

- *with international search report (Art. 21(3))*
- *before the expiration of the time limit for amending the claims and to be republished in the event of receipt of amendments (Rule 48.2(h))*

**TUBULAR BODY CONTAINING COMPRESSIBLE PARTICLES, AND
METHOD OF ATTENUATING ANNULAR PRESSURE**

5

Cross-Reference to Related Application

[0001] This application claims the benefit of U.S. Provisional Application 62/758,862 filed November 12, 2018 entitled, "Tubular Body Containing Compressible Particles, and Method of Attenuating Annular Pressure" the entirety of which is incorporated by reference herein.

10 This application is technically related to U.S. Provisional Application 62/758,843 filed November 12, 2018 entitled, "Method of Designing Compressible Particles Having Buoyancy In A Confined Volume" the entirety of which is incorporated by reference herein. This application is also technically related to U.S. Provisional Application 62/758,846 filed November 12, 2018 entitled, "Buoyant Particles Designed For Compressibility" the entirety of

15 which is incorporated by reference herein. This application is also technically related to U.S. Provisional Application 62/758,852 filed November 12, 2018 entitled, "Method Of Placing A Fluid Mixture Containing Compressible Particles Into A Wellbore" the entirety of which is incorporated by reference herein. This application is also technically related to U.S. Provisional Application 62/758,858 filed November 12, 2018 entitled, "A Fluid Mixture Containing

20 Compressible Particles" the entirety of which is incorporated by reference herein.

Background of the Invention

[0002] This section is intended to introduce various aspects of the art, which may be associated with exemplary embodiments of the present disclosure. This discussion is believed to assist in providing a framework to facilitate a better understanding of particular aspects of

25 the present disclosure. Accordingly, it should be understood that this section should be read in this light, and not necessarily as admissions of prior art.

Field of the Invention

[0003] The present disclosure relates to the field of hydrocarbon recovery operations. More specifically, the present invention relates to the drilling and completion of wells. Further,

30 the invention relates to a well completion having a tubular body specially fitted to contain compressible particles along a trapped annulus.

Technology in the Field of the Invention

[0004] In the drilling of oil and gas wells, a wellbore is formed using a drill bit that is urged downwardly at a lower end of a drill string. The drill bit is rotated while force is applied

35 through the drill string and against the rock face of the formation being drilled. After drilling

to a predetermined depth, the drill string and bit are removed and the wellbore is lined with a string of casing.

[0005] In completing a wellbore, it is common for the drilling company to place a series of casing strings having progressively smaller outer diameters into the wellbore. A first string of casing is placed from the surface and down to a first drilled depth. This casing is known as surface casing. In the case of offshore operations, this casing may be referred to as a conductor pipe. One of the main functions of the initial string of casing is to isolate and protect the shallower, fresh water bearing aquifers from contamination by wellbore fluids. Accordingly, this casing string is almost always cemented entirely back to the surface.

10 [0006] One or more intermediate strings of casing is also run into the wellbore. Each successive pipe string extends to a greater depth than its predecessor, and has a smaller diameter than its predecessor.

[0007] The process of drilling and then cementing progressively smaller strings of casing is repeated several times until the well has reached total depth. A final string of casing, referred to as production casing, is used along the pay zones. In some instances, the final string of casing is a liner, that is, a pipe string that is hung in the wellbore using a liner hanger. Frequently today, the final string of casing is a long pipe string that extends along a horizontal portion (or "leg") of a wellbore.

[0008] The process of running a string of casing into the wellbore will form an annular area (or "annulus") between the pipe and the surrounding borehole. A cementing operation is typically conducted in order to fill or "squeeze" selected annular areas with a column of cement. The combination of cement and casing strengthens the wellbore and facilitates the zonal isolation of certain sections of a hydrocarbon-producing formation (or "pay zones") behind the casing.

25 [0009] In most wellbore completion jobs today, especially those involving so called unconventional formations where high-pressure hydraulic operations are conducted downhole, the surface casing and perhaps the first intermediate string of casing are entirely cemented up to the surface. Hydraulic cements, usually Portland cement, are used to cement the tubular bodies within the wellbore. However, in some completions, particularly those where overlapping strings of casing extend to the surface, the operator may choose to leave an extended portion of certain casing strings without cement. This saves the drilling company time and the well operator money. However, this also means that upon completion an extended section of wellbore will have wellbore fluids residing on top of a column of cement up to the well head.

[0010] **Figure 1A** is a cross-sectional view of a wellbore **100** undergoing completion. The wellbore **100** defines a bore **10** that has been drilled from an earth surface **105** into a subsurface **110**. The wellbore **100** is formed using any known drilling mechanism, but preferably using a land-based rig or an offshore drilling rig on a platform. For deeper horizontal wells such as the one shown in **Figure 1A**, the wellbore may be formed at least in part through the use of a downhole motor and MWD electronics.

[0011] The wellbore **100** is completed with a first string of casing **120**, sometimes referred to as surface casing. The wellbore **100** is further completed with a second string of casing **130**, typically referred to as an intermediate casing. In deeper wells, that is wells completed below 7,500 feet, at least two intermediate strings of casing will be used. In **Figure 1A**, a second intermediate string of casing is shown at **140**.

[0012] The wellbore **100** is finally completed with a string of production casing **150**. In the view of **Figure 1A**, the production casing extends from the surface **105** down to a subsurface formation, or “pay zone” **115**. The wellbore **100** is completed horizontally, meaning that a horizontal “leg” **50** is provided. The leg **50** is formed from the end of the production casing **150**. The leg **50** includes a heel **153** and a toe **154** along the pay zone **115**. In this instance, the toe **154** defines the end (or “TD”) of the wellbore **100**.

[0013] It is observed that the annular region around the surface casing **120** is filled with cement **125**. The cement (or cement matrix) **125** serves to isolate the wellbore from fresh water zones and potentially porous formations around the casing string **120** and near the surface **105**.

[0014] The annular regions around the intermediate casing strings **130**, **140** are also filled with cement **135**, **145**. Similarly, the annular region around the production casing **150** is filled with cement **155**. However, the cement **135**, **145**, **155** is only placed behind the respective casing strings **130**, **140**, **150** up to the lowest joint of the immediately surrounding casing string, or cement shoe. Thus, a non-cemented annular area **132** is preserved above the cement matrix **135**; a non-cemented annular area **142** is preserved above the cement matrix **145**; and a non-cemented annular area **152** is preserved above the cement matrix **155**.

[0015] **Figure 1B** is a perspective view of the wellbore **100** of **Figure 1A**, or at least the upper half of the wellbore **100**. Here, casing strings **120**, **130**, **140** and **150** are again shown. In addition, cement matrices **125**, **135**, **145** and **155** are visible. Finally, non-cemented annular areas **132**, **142** and **152** are shown.

[0016] An annulus can be considered “trapped” if the cement pumping places the top of cement (or “TOC”) higher than the previous shoe. Alternately, if the shoe remains open to the formation (not blocked by the cement) solids may settle out from the annular fluid, effectively

plugging up the bottom of the annulus. In any instance, those of ordinary skill in the art will understand that the non-cemented annular areas **132**, **142**, **152** are not unfilled above the TOC; rather, they are left with wellbore fluids therein. Such fluids may include drilling fluids, aqueous acid, and formation gas. When the well is completed, a wellhead is placed over the annular areas **132**, **142**, **152**, sealing these regions. For this reason each may be referred to as a “trapped annulus.”

[0017] During the course of producing hydrocarbons, warm production fluids flow through a tubing string (not shown) up to the surface. These fluids raise the temperature inside the wellbore **100**, including the fluids inside the one or more trapped annuli **132**, **142**, **152**. This, in turn, will increase the pressure within each trapped annulus. (Note that the effect of a trapped annulus is that the fluid in the annulus has no path to escape should the pressure rise.) This pressure can exceed the pressure ratings (burst or collapse pressures) of the inner strings of casing. For example, a trapped annulus can lead to pipe collapse or even well failure.

[0018] Accordingly, a need exists for an improved pipe design that can absorb burst pressure as wellbore temperature is increased. Further, a need exists for a unique tubular body holding collapsible particles capable of absorbing an increase in fluid pressure within a trapped annulus. A need further exists for a method of mitigating pressure within a trapped annulus using designed compressible particles.

Brief Summary of the Disclosure

[0019] A tubular body for a wellbore is first provided herein. The tubular body defines a pipe having a box end and a pin end. An elongated wall extends there between. The wall forms an outer diameter of the pipe.

[0020] The tubular body also includes a filter screen. The filter screen is disposed around the outer diameter of the wall along at least a portion of the pipe. The filter screen defines a generally cylindrical body having a first end and an opposing second end. A plurality of slots is provided along the cylindrical body between the first and second ends, creating fluid and pressure communication.

[0021] The filter screen is preferably fabricated from a metal alloy or ceramic. The screen is secured to the elongated pipe body by welding or, perhaps, by collars or by adhesive.

[0022] The tubular body additionally includes a plurality of compressible particles. The compressible particles reside within the filter screen and around the elongated wall. Each of the compressible particles is fabricated to collapse in response to fluid pressure communicated through the slots or pore openings in the filter screen.

[0023] Preferably, the particles will have a compressibility of between 10% and 30%. More preferably, the particles will have a compressibility of between 14% and 22% (up to 10,000 psi). The particles may also have a resiliency of between 87% and 117%.

[0024] Each of the particles may comprise carbon. At least some of the compressible
5 particles may comprise graphite or graphene beads. In one embodiment, each of the compressible particles comprises a porous graphite carbon (PGC) material. In this instance, an inner core is composed of amorphous carbon, while an outer shell is composed of graphitic carbon. Both the inner core and the outer shell are porous.

[0025] In another embodiment, each of the compressible particles comprises pore channels
10 coated with natural rubber or a polymer serving as a synthetic rubber.

[0026] In any instance, each of the compressible particles may have an outer diameter that is from 10 μm to 1,000 μm , depending on the specific particle size distribution. More preferably, the particle size distribution will be between 100 μm to 700 μm , and may average around 250 μm . The particles may each have a porosity of between 5 and 40%, or the particles
15 together may have an average porosity of between 10% and 25%.

[0027] A wellbore is also provided herein. The wellbore includes a first string of casing and a second string of casing. The first string of casing surrounds an upper portion of the second string of casing, forming a trapped annulus.

[0028] The wellbore has at least one tubular body placed in series along the second string
20 of casing adjacent the trapped annulus. The tubular body is in accordance with the tubular body described above in its various embodiments. In this respect, the tubular body serves as a filter screen holding a plurality of compressible particles against the outer wall of the pipe body. Each of the compressible particles is fabricated to collapse in response to fluid pressure communicated through the filter screen during production operations.

[0029] In one aspect, a series of tubular bodies having filter screens is placed along the
25 trapped annulus, creating at least 1,000 feet in length for the combined filter screens.

[0030] In addition, a method of mitigating pressure within a trapped annulus is provided
30 herein. In one aspect, the method first comprises forming a wellbore. The method additionally includes placing a first string of casing within the wellbore, and then placing a second string of casing within the wellbore. The first string of casing surrounds an upper portion of the second string of casing, forming a trapped annulus.

[0031] The method further includes placing at least one tubular body along the second string of casing adjacent the trapped annulus. The at least one tubular body is in accordance with the tubular body described above in any of its various embodiments. In this respect, the

tubular body serves as a filter screen holding a plurality of compressible particles against the outer wall of the elongated pipe body. Each of the compressible particles is fabricated to collapse in response to fluid pressure communicated through the filter screen during production operations.

5 [0032] The step of placing at least one tubular body along the second string of casing adjacent the trapped annulus may include selecting a location for one or more tubular bodies along the trapped annulus. The operator may choose to locate tubular bodies near the top of the column forming the trapped annulus, or alternatively near the bottom of the column forming the trapped annulus. Those of ordinary skill in the art will understand that the one or
10 more tubular bodies are threadedly placed in series with a string of casing. In one arrangement, 1,000 feet of combined filter screens having compressible particles are placed generally central to the trapped annulus.

[0033] In one aspect, the method further includes selecting a geometry for the compressible particles within the filter screens. The method may then further include: producing
15 hydrocarbons from a subsurface formation up the wellbore; and using the compressible particles, absorbing at least a portion of pressure that builds in the trapped annulus during the producing step.

Brief Description of the Drawings

[0034] So that the manner in which the present inventions can be better understood, certain
20 illustrations, charts and/or flow charts are appended hereto. It is to be noted, however, that the drawings illustrate only selected embodiments of the inventions and are therefore not to be considered limiting of scope, for the inventions may admit to other equally effective embodiments and applications.

[0035] Figure 1A is a side view of a wellbore. The wellbore has a plurality of casing
25 strings cemented into place, and is completed with a string of production casing.

[0036] Figure 1B is a side perspective view of an upper half of the wellbore of Figure 1A. Three annular regions are shown as trapped annuli.

[0037] Figure 2A is a perspective view of a tubular body of the present invention, in one
30 embodiment. In a preferred aspect, the tubular body is deployed in a wellbore as part of a string of casing.

[0038] Figure 2B is a perspective, cut-away view of a filter screen placed on the tubular body of Figure 2A. The filter screen holds a plurality of compressible particles.

[0039] Figures 3A and 3B present side views of filter screens in alternate arrangements. Either filter screen may be fitted around an outer body of a joint of casing, and at least partially filled with compressible particles.

5 [0040] Figure 3A presents the filter screen of Figure 2A in an embodiment that is similar to a sand screen.

[0041] Figure 3B presents the filter screen of Figure 2A as a slotted tubular.

[0042] Figure 4 is a perspective view of the upper portion of a wellbore having trapped annuli. An intermediate string of casing has received a series of filter screens, such as either of the filter screens of Figures 3A or 3B.

10 [0043] Figure 5A is another perspective view of the upper portion of a wellbore, in an alternate embodiment. In this instance, a column of carrier fluid holding compressible particles is placed in the unfilled annular space around an intermediate string of casing. The compressible particles are suspended in and dispersed along the column of carrier fluid.

[0044] Figure 5B is still another perspective view of the upper portion of a wellbore. In 15 this instance, a column of carrier fluid holding compressible particles is again placed in the unfilled annular space around an intermediate string of casing. The compressible particles are suspended more densely central to the trapped annulus.

[0045] Figure 5C is still another perspective view of the upper portion of a wellbore. In 20 this instance, a column of carrier fluid holding compressible particles is again placed in the unfilled annular space around an intermediate string of casing. The compressible particles are suspended more densely along an upper end of the trapped annulus.

[0046] Figure 6 is a flow chart showing steps for preparing a mixture of compressible particles for a wellbore annular area.

25 [0047] Figure 7A is a top view of an illustrative compressible particle as may be used in an annular region of a wellbore, in a first embodiment.

[0048] Figure 7B is a top view of an illustrative compressible particle as may be used in an annular region of a wellbore, in a second less porous embodiment.

[0049] Figure 7C is a top view of an illustrative coating that may be used around a compressible particle.

30 [0050] Figure 8A is a top view of an illustrative compressible particle. The particle presents a geometry having a smooth outer surface and an oval profile.

[0051] Figure 8B is another illustrative compressible particle. Here, the particle has an irregular shape.

[0052] Figure 9A is a sectional view of a carrier fluid wherein compressible fluids are suspended. The carrier fluid has received a plurality of regularly-shaped, polygonal compressible particles.

[0053] Figure 9B is another sectional view of a carrier fluid wherein compressible fluids are suspended. In this view, a coating has been applied to the compressible particles. The coating is charged, causing the particles to repel each other, thereby enhancing disbursement.

[0054] Figure 10A is a cartesian chart showing compressibility of particles as a function of pressure. This demonstrates a “compressibility response.”

[0055] Figure 10B is a graph showing a pressure profile within the annular region of a wellbore. Pressure is shown as a function of depth, both before and after pressure build-up due to production operations.

[0056] Figure 11A is an illustrative view of an annular region, representing a small portion of an annular column for a wellbore. The annular region holds a plurality of compressible particles suspended in an aqueous carrier fluid. The compressible particles are designed to have a density that is lower than the density of the fluid, thereby enabling buoyancy.

[0057] Figure 11B is an enlarged view of one of the particles from Figure 11A. It can be seen that the collapsible particle is designed to be considerably larger in size compared to weighting agent particles in the carrier fluid.

Detailed Description of Certain Embodiments

Definitions

[0058] For purposes of the present application, it will be understood that the term “hydrocarbon” refers to an organic compound that includes primarily, if not exclusively, the elements hydrogen and carbon. Hydrocarbons may also include other elements, such as, but not limited to, halogens, metallic elements, nitrogen, oxygen, and/or sulfur.

[0059] As used herein, the term “hydrocarbon fluids” refers to a hydrocarbon or mixtures of hydrocarbons that are gases or liquids. For example, hydrocarbon fluids may include a hydrocarbon or mixtures of hydrocarbons that are gases or liquids at formation conditions or at surface conditions. Hydrocarbon fluids may include, for example, oil, natural gas, coalbed methane, shale oil, pyrolysis oil, pyrolysis gas, a pyrolysis product of coal, and other hydrocarbons that are in a gaseous or liquid state, or combination thereof.

[0060] As used herein, the terms “produced fluids,” “reservoir fluids” and “production fluids” refer to liquids and/or gases removed from a subsurface formation, including, for example, an organic-rich rock formation. Produced fluids may include both hydrocarbon fluids and non-hydrocarbon fluids. Production fluids may include, but are not limited to, oil,

natural gas, pyrolyzed shale oil, synthesis gas, a pyrolysis product of coal, oxygen, carbon dioxide, hydrogen sulfide and water.

[0061] As used herein, the term “fluid” refers to gases, liquids, and combinations of gases and liquids, as well as to combinations of gases and solids, combinations of liquids and solids,
5 and combinations of gases, liquids, and solids.

[0062] As used herein, the term “wellbore fluids” means water, hydrocarbon fluids, formation fluids, or any other fluids that may be within a wellbore during a production operation. Wellbore fluids may include a weighting agent that is residual from drilling mud.

[0063] As used herein, the term “gas” refers to a fluid that is in its vapor phase. A gas may
10 be referred to herein as a “compressible fluid.” In contrast, a fluid that is in its liquid phase is an “incompressible fluid.”

[0064] As used herein, the term “subsurface” refers to geologic strata occurring below the earth's surface.

[0065] As used herein, the term “formation” refers to any definable subsurface region
15 regardless of size. The formation may contain one or more hydrocarbon-containing layers, one or more non-hydrocarbon containing layers, an overburden, and/or an underburden of any geologic formation. A formation can refer to a single set of related geologic strata of a specific rock type, or to a set of geologic strata of different rock types that contribute to or are encountered in, for example, without limitation, (i) the creation, generation and/or entrapment
20 of hydrocarbons or minerals, and (ii) the execution of processes used to extract hydrocarbons or minerals from the subsurface.

[0066] As used herein, the term “wellbore” refers to a hole in the subsurface made by drilling or insertion of a conduit into the subsurface. A wellbore may have a substantially circular cross section. The term “well,” when referring to an opening in the formation, may be
25 used interchangeably with the term “wellbore.”

[0067] As used herein and unless specified otherwise, the terms “annular region” “annulus,” “containment area,” or the like refer to the volume between an inner tubular member and an outer tubular member or wellbore wall, the term “outer” meaning having a larger radius with respect to the inner member. As used herein, the annular region is normally isolated, trapped, or otherwise confined annular region, in that it is not in or no longer in circulating
30 fluid communication with an inner bore of the inner tubular member during an operational period for the wellbore. These terms as used herein typically refers to the annuluses between casing and/or liner tubular strings, or between a production tubing string and a production casing or liner, above a seal bore or production packer, as when a well is constructed wellbore

fluids within these types of annuluses typically become trapped and are no longer capable of circulating fluid therein or therefrom.

Description of Selected Specific Embodiments

[0068] **Figure 2** is a perspective view of a tubular body **200** of the present invention, in one embodiment. In a preferred aspect, the tubular body **200** is deployed in a wellbore as part of a string of casing. Stated another way, the tubular body **200** may be threadedly placed in series with a string of casing (such as casing string **140** of **Figure 1B**).

[0069] The tubular body **200** is specifically designed to reside along an open annular region such as region **142**. The tubular body **200** may be of a standard length for a pipe joint, such as 30 feet, 32 feet or even 40 feet.

[0070] The tubular body **200** comprises an upper end **210** and a lower end **214**. In the vernacular of the industry, the upper end **210** is the box end while the lower end **214** is the pin end. The box end **210** comprises internal threads **212** that are configured to threadedly connect with the pin end of an immediately upper joint of pipe (not shown). Reciprocally, the pin end **214** is configured to “stab” into the box end of an immediately lower joint of pipe (not shown) for threaded connection.

[0071] The tubular body **200** defines an elongated wall forming a pipe **220** (or elongated pipe body). Placed along the outer diameter of the pipe **220** is a filter screen **230**. The filter screen **230** has an upper end **232** and a lower end **234** and is designed to contain a plurality of compressible particles. An example of particles within the screen **230** is shown at **240** in **Figure 2B**, discussed further below.

[0072] In one aspect, the filter screen **230** has both an inner surface **235** and an outer surface **236**, forming a defined cylindrical body. The inner surface **235** resides closely along the pipe body **220**. The filter screen **230** may be welded onto the pipe **220**. Alternatively, the filter screen **230** may be secured to the pipe **220** through a friction fit or by an adhesive to form a cylindrical body. In another embodiment, the screen **230** does not have an inner surface, but is securely fastened to the outer diameter of the pipe body **220** itself to contain the compressible particles **240**.

[0073] The filter screen **230** is fabricated from a porous material. In the embodiment shown in **Figure 2A**, the material is a permeable polymeric material having micro-pores or slots that form a mesh. Suitable polymeric materials may include neoprene, polyurethane rubber, vinyl, nitrile rubber, butyl rubber, silicone rubber, or combinations thereof. Alternatively, and as described further below in connection with **Figures 3A** and **3B**, the material may be a metal alloy or a ceramic material having pre-fabricated micro-slots.

[0074] **Figure 2B** is a perspective, cut-away view of the screen **230** of **Figure 2A**. The screen **230** is again fitted onto an elongated pipe joint **220**. The pipe joint **220** may be deployed in a wellbore as part of a string of casing. The process of fitting the annular screen **230** onto the body **220** of the pipe joint **220** may involve wrapping the screen **230** around the pipe body
5 **220** and then securing it through friction or heat melding. More preferably, the process involves sliding the annular screen **230** onto the pipe body **220** (over the pin end **214**) and then welding the screen **230** onto the pipe body **220**. In this instance, the screen **230** is fabricated from a metal material or at least has metal frame members or ribs for welding.

[0075] In **Figure 2B**, an inner bore **205** of the pipe **220** can be seen. The pipe **220** may be
10 fabricated from any steel material having burst and collapse pressure ratings suitable for a wellbore environment. Those of ordinary skill in the art will understand that with the advent of hydraulic fracturing, burst ratings of pipe (and particularly of production casing) are much higher than in older wells and may withstand pressures of up to 15,000 psi. Of course, when welding or otherwise securing the screen **230** onto the outer diameter of the pipe body **220** care
15 must be taken not to compromise the integrity of the joint **200** as a pressure vessel by scoring the pipe **220**.

[0076] As an alternative, the pipe body **220** may be fabricated from ceramic. In this instance, the screen **230** is preferably secured to the pipe body **220** through a mechanical connection such as a latch or raised surfaces.

[0077] An encased area **238** is provided within the screen **230**. As noted above, the
20 encased area **238** holds a plurality of compressible particles **240**. Preferably, a sufficient number of compressed particles are used to fill (or substantially fill) the encased area **238**. The outer surface **236** of the filter screen **230** and the compressible particles **238** are designed to be sturdy enough to hold a cylindrical shape around the pipe body **220** until a designated annular
25 pressure is reached. Once the designated annular pressure is reached, the compressible particles **240** will begin to collapse, thereby absorbing pressure within the annular pressure and reducing the likelihood of the pipe **220** collapsing during production operations.

[0078] As noted, the screen **230** may be fabricated from a polymeric material having
30 micro-pores. In this instance, when the designated annular pressure that causes compression or collapse of the compressible particles **240** is reached, the porous, polymeric body **236** may at least partially collapse around the compressed particles **240**. Preferably, the collapsibility response (or pressure rating) of the particles **240** is less than the collapsibility response (or pressure rating) of the screen **230**, though this is a matter of engineer's choice.

[0079] **Figures 3A and 3B** present alternate embodiments of an annular filter screen **230**. **Figure 3A** presents the screen as a wound filter screen **300A**. The filter screen **300A** is similar to a known sand screen. The filter screen **300A** may be fabricated from either steel (or any corrosion-resistant alloy) or ceramic. Preferably, the filter screen **300A** is fabricated from metal wire **310A** that is wound around and supported by elongated vertical ribs (not visible). Micro-slots are preserved between the wire **310A** to enable pressure communication into the containment area **238**.

[0080] **Figure 3B** presents the filter screen **300B** as a slotted tubular. The filter screen **300B** defines a metal tubular body **310B** with a plurality of dedicated slots **315B**. The slots **315B** again enable pressure communication into the containment area **238**.

[0081] Each filter screen has an upper end **312** and a lower end **314**. The filter screens **300A** or **300B** are designed to be fitted around an outer diameter of the pipe **220** and filled with compressible particles **240**. Each filter screen **300A** or **300B** will present slots **315A**, **315B** that permit fluid and pressure communication between the wellbore and the compressible particles. The gap size of the slots **315A**, **315B** in the screens **300A**, **300B** may range in size from 10 μm to 100 μm , depending on the specific particle size distribution. At the same time, the particle size distribution will be between 10 μm and 700 μm (dry). It is understood that the gaps **315A**, **315B** must be smaller than the diameters of the compressible particles **240**.

[0082] Use of the screen **230** (or screens **300A** or **300B**) enables the delivery of the compressible particles **240** within a “trapped annulus.” In this respect, it is not necessary to pump compressible particles **240** ahead of the cement column (e.g., column **145**) for placement within the annular area (e.g., annular area **142**). Extending the length of the screen **230** and/or increasing the density of the particles **240** within the containment area **238** and/or using multiple tubular bodies **200** increases the pressure absorption abilities within a trapped annulus **142**, **152**.

[0083] It is also noted that the use of the tubular body **200** with a screen **230**, **300A** or **300B** enables the operator to place the particles **240** in a specific location in the trapped annulus. For example, the operator may desire to keep the compressible particles central to the trapped annulus. In this instance, the operator may place one or more tubular bodies **200**, in series, generally half way between the top and the bottom of the fluid column making up the trapped annulus.

[0084] It is preferred that the filter screen **230**, **300A** or **300B** cover about 80% of the length of the pipe body **220**. The operator may place one, two, or even ten tubular bodies **200** having the filter screen **230**, **300A** or **300B** along an annular region **142**. The tubular bodies

200 may be connected in series, or may be spaced apart by placing standard casing joints between tubular bodies **200**.

[0085] **Figure 4** is a perspective view of the upper portion of a wellbore **400**. The wellbore **400** is in accordance with the wellbore **100** of **Figure 1B**. In this respect, the wellbore **400** is completed with a series of casing strings including surface casing **120**, intermediate casing strings **130** and **140**, and production casing **150**.

[0086] In **Figure 4**, Arrow **F** is shown. This indicates a flow of production fluids during a hydrocarbon production operation. It is understood that the production fluids are produced through a production string (not shown). The production fluids “**F**” are warm, causing a temperature within the various annular regions **132**, **142**, **152** to increase. This, in turn, will increase the temperature of the fluids within these annular regions **132**, **142**, **152**. The increase in temperature within the defined volumes will cause a corresponding increase in pressure.

[0087] To accommodate the pressure increase within the trapped annulus **142**, a series of novel tubular bodies **200** is provided. Each body includes a permeable filter screen **230** containing a plurality of compressible particles **240**. The particles **240** are preferably fabricated from compressive carbon beads such as mesocarbon micro-beads. Mesocarbon micro-beads (“MSMB’s”) represent a porous graphite carbon (PGC) material wherein an inner core is composed of amorphous carbon, while an outer shell is composed of graphitic carbon. Both the inner core material and the outer shell material are porous.

[0088] MCMB’s may be fabricated from coal tars. In one aspect, a surface-coated micro-bead material may be produced by carbonizing thermosetting resin. Such beads are available under the trade name NicaBeads® and are produced by Nippon Carbon Co. Ltd. of Tokyo, Japan.

[0089] Other materials may also be used for the compressible particles **240**. For example, a composite of polymer and graphite may be formed into beads. The graphite material may include graphite carbons. Such materials are available from Superior Graphite Co. of Chicago Illinois. Alternatively, graphene beads having a high porosity to enhance compressibility may be used. Pore channels within the beads may optionally be coated with natural rubber or a polymer or pseudo-polymer serving as a synthetic rubber.

[0090] In one arrangement, flexible compressible beads comprised of a polymeric material are used. For example, a co-polymer of methylmethacrylate and acrylonitrile may be used. Styrofoam or polystyrene may also be used alone or in combination with this co-polymer. In another embodiment, a terpolymer of methylmethacrylate, acrylonitrile and dichloroethane is used. The dichloroethane may be a vinylidene dichloride. Preferably, the beads are not infused

with gas so as to limit expansion of the bead material upon exposure to heat during wellbore operations.

[0091] Other polymeric materials may be used such as neoprene, polyurethane rubber, vinyl, nitrile rubber, butyl rubber, EPDM rubber, silicone rubber, or combinations thereof. The material may be continuous or it may be porous, having a porosity of 5% to 40%, or more preferably between 10% and 20%. It is understood that the above materials are merely illustrative.

[0092] Preferably, the particles will have a compressibility of between 10% and 30%. More preferably, the particles will have a compressibility of between 14% and 22% (up to 10,000 psi).

[0093] Preferably, each of the particles has a resiliency of between 80% and 120%. More preferably, each of the particles has a resiliency of between 87% and 117%.

[0094] As noted, the particles **240** are confined within a containment area (shown at **238** in **Figure 2**) defined by a filter screen. In **Figure 4**, that the wellbore **400** has received a series of tubular bodies **200**, each having an elongated filter screen **230**. While the screen is indicated as element **230**, the screen may alternatively be filter screen **300A** of **Figure 3A** or **300B** of **Figure 3B**. The use of a filter screen **230** allows the operator to select the depth at which the particles **240** are placed along the trapped annulus without having to worry that the particles may float to the top of the column or settle to the bottom of the column along the trapped annulus **142**. Stated another way, the operator can use particles **240** having a desired compressibility without worrying about bed heights at the bottom or the top of the annulus **142**. Since the particles **240** are contained, the bed height is generally pre-determined by the height of the filter screen **230** and the number of tubular bodies **200** employed in series. Further, the operator may be less concerned with particle density since buoyancy is not a factor.

[0095] In the embodiment described in **Figure 4**, the compressible particles **240** are contained within one or more annular screens **230** placed around a pipe joint **220**, (e.g., a joint of casing). However, an alternative solution to alleviating pressure build-up in an annular area (such as area **142**) is to use collapsible particles dispersed in the fluid residing along the fluid column in the annular area. Once again, the particles are volumetrically compressed as the pressure increases during production operations, resulting in additional volume into which the fluid can expand. This may be in lieu of or in addition to use of tubular bodies **200**.

[0096] **Figure 5A** presents a cross-sectional view of the upper portion of a wellbore **500A**. The wellbore **500A** extends into a subsurface formation **510**. As with wellbore **400** of **Figure 4**, wellbore **500A** has been completed with a series of casing strings. These include a surface

casing string **520** and at least two intermediate casing strings **530** and **540**. In addition, a production casing **550** is used, providing for a “cased hole.”

[0097] Annular area **525** resides around the surface casing string **520**. Similarly, annular areas **535** and **545** reside around casing strings **530** and **540**, respectively. Additionally, annular area **555** resides around production casing **550**. Cement is placed around the lower portions of annular areas **535** and **545**. Preferably, cement is also placed around at least a lower portion (not shown) of annular area **555** up to a bottom of casing string **540**. In the illustrative view of **Figure 5A**, only annular area **525** is completely filled with cement.

[0098] It is observed that in the wellbore **500** no annular screen is used as in **Figure 4**; instead, a column of carrier fluid **543** holding compressible particles **546** is used. The carrier fluid **543** resides in an annular area **542** around the production casing **540**, forming a fluid column or bed. The carrier fluid **543** is placed in what will otherwise be a “trapped annulus” **542** above a column of cement **545**.

[0099] In the arrangement of **Figure 5A**, the compressible particles **546** are suspended in and dispersed somewhat evenly along the column of carrier fluid **543**. During production, hydrocarbon fluids are lifted to a surface **505** in accordance with Arrow **F** using a production tubing (not shown). Formation fluids may flow to the surface **505** under *in situ* pressure; alternatively, formation fluids may be raised to the surface **505** using an artificial lift technique. In either instance, as formation fluids are produced according to Arrow **F**, the temperature in the wellbore **500A** will increase. This, in turn, will increase pressure within the trapped annulus **542** due to fluid expansion.

[0100] To alleviate this pressure and to protect the adjacent casing strings **530**, **540**, the particles **546** are volumetrically compressed. This results in additional volume into which the fluid can expand as the pressure increases during production operations.

[0101] To maximize the effectiveness of the compressible particles **546**, it is ideal if all of the particles **546** are exposed to pressure within the trapped annulus **542** equally. In this way the particles **546** can compress proportionally. This may not be achieved if all of the particles **546** rise together to the top of the trapped annulus **542**. In this respect, at least some of the particles **546** will be lost during the periodic annulus bleed downs that occur during production operations.

[0102] Similarly, it may be undesirable for the particles **546** to settle together at the bottom of the fluid column **543**, forming a bed. Such a bed would represent a collection of particles **546** which, depending on the number of particles used and the height and area of the annulus **542**, could prevent pressure contact across all of the fluid column **543**. Stated another way,

fluid pressure may not fully penetrate through the entirety of the bed height. In addition, if the particles **546** settle tightly anywhere along the column **543** they could build an impermeable bridge resulting in trapping that, without the addition of the compressible particles **546**, was an open annulus along the column **543**, thus creating a problem where previously none had
5 existed.

[0103] To ensure that the particles **546** remain well-dispersed along the annular column **543**, consideration should be given to the density of the particles **546** relative to the carrier fluid **543**. A lower density can be achieved by designing large particle size, increased pore volume, or providing random shapes that mitigate packing. It is believed that irregular particle
10 shapes with higher surface area allows for better suspension in the fluid column. Preferably, the density of the carrier fluid **543** is between 12 ppg and 12.8 ppg (1.43 g/cc to 1.54 g/cc) and the densities of the compressible particles **546** span across this range. In one aspect, the particles **546** may range in density from 0.5 to 2.5 specific gravity. A uniform suspension of particles **546** can be achieved by designing the carrier fluid **543** density to generally match the
15 density of the particles **546** (or vice versa).

[0104] The particles **546** are preferably fabricated from a compressive carbon such as mesocarbon micro-beads or graphite as described above. Alternatively, a composite of polymer and graphite may be formed into beads.

[0105] In one arrangement, flexible compressible beads comprised of a polymeric material
20 are used. For example, a co-polymer of methylmethacrylate and acrylonitrile may be used. Styrofoam or polystyrene may also be used alone or in combination with this co-polymer. In another embodiment, a terpolymer of methylmethacrylate, acrylonitrile and dichloroethane is used. The dichloroethane may be a vinylidene dichloride. Preferably, the beads are not infused with gas so as to limit expansion of the bead material upon exposure to heat during productions
25 operations.

[0106] Consideration should also be given to particle size. The compressible particles **240** may range in size from 10 μm to 700 μm in diameter, and more preferably between 40 μm and 700 μm . In one aspect, at least 50% of the compressible particles have a diameter range that is from 50 μm to 600 μm , with an average size that is between 200 μm and 400 μm (in dry
30 state).

[0107] The slots **310A** or **310B** are sized to contain the particles **546** while allowing ingress of fluid and pressure. During operation, pressure need only migrate from the O.D. of the screen **300A** or **300B** where the fluid is present to the O.D. of the pipe joint **220**.

[0108] **Figure 6** is a flow chart showing steps for a method **600** of designing a mixture having compressible particles. The mixture will be comprised of the carrier medium **543** and the compressible particles **546**. The aim of the method **600** is to provide for a desired distribution of particles **546** across a trapped annulus **542**.

5 [0109] The method **600** first includes selecting a carrier fluid. This is shown in Box **610**. The carrier fluid is preferably an aqueous liquid comprised primarily of fresh water, salt water or brine. Water based drilling fluid may also be considered wherein the drilling fluid comprises a sampling of weighting agent. Weighting agent particles are shown at **1130** in **Figure 11B**.

[0110] Fresh water, of course, has a specific gravity of 1.0. Where salt or minerals are present, the specific gravity will be increased. The carrier fluid may need to be blended to ensure a generally homogenous composition and specific gravity.

[0111] The method **600** next includes selecting a density range for the compressible particles **546**. This is provided in Box **620**. The particles **546** may have a range in density from 12.0 ppg to 12.8 ppg. Ideally, the compressible particles **546** will have a specific gravity ("SG") that is close to that of the carrier fluid **543**. Preferably, the SG of the compressible particles **546** will have a range of plus / minus 0.5 of the carrier fluid **543**. This will prevent particles from settling at the bottom or rising to the top of the narrow annulus **542**, forming a bed that isolates the annulus (or at least many of the particles) from pressure.

[0112] In the narrow confines of an annulus **542**, forming a dense particle bed at the top or bottom of the annulus could be detrimental. In this respect, as the particles bridge off they will limit the fluid's pressure penetration from one end of the bed to the other end of the bed. The consequence is that not all particles would be compressed as the pressure increases in the trapped annulus **542**. If all of the particles **546** settle at the bottom of the column **543** where an open shoe was present, the bed could restrict pressure distribution up into the fluid column

25 **543**.

[0113] Notwithstanding the arrangement of **Figure 5A**, in some instances the operator may want to cluster a majority of the particles **546** central to the trapped annulus **542**. **Figure 5B** is another perspective view of the upper portion of a wellbore **500B**. The wellbore **500B** is constructed in accordance with the wellbore **500A** of **Figure 5A** and extends into the subsurface formation **510**. A column of carrier fluid **543** holding compressible particles **546** is again placed in the unfilled annular space **542** around an intermediate string of casing **540**. The compressible particles **546** are suspended together within the column of carrier fluid **543**.

30 [0114] In **Figure 5B**, the concentration of particles **546** is higher along a central portion **546B** of the annular region **542** than it is near the bottom. This is due to an intentional variation

of the density of the particles **546** as mixed in the carrier fluid **543**. One way of adjusting the location of the particles **546** along the trapped annulus **542** is by increasing or decreasing the porosity of the particles. Some particles having a lower density are included, which will generally rise to the top of the fluid column **543**, while some particles having a higher density will be included which will generally settle to the bottom of the fluid column **543**. In the arrangement of **Figure 5B**, the particles **546** are generally dispersed along the fluid column **543**, but a higher percentage of particles have a SG that approximates the density of the carrier medium **543**, causing most of the particles **546** to settle along the central portion **546B**.

[0115] **Figure 7A** is a top view of an illustrative compressible particle **700A** as may be used in an annular region **542** of a wellbore, in a first embodiment. Here it can be seen that the particle **700A** has a number of holes **710**. The holes **710** increase porosity and create buoyancy. The holes **710** may further enhance compressibility response.

[0116] The compressible particle **700A** shown in **Figure 7A** is preferably a carbon or carbon-based material. More preferably, the material comprises graphene, representing carbon material placed in layers. Graphene particles are shown to provide low-density, high compressibility and high elasticity. In addition, graphene particles can have resistance to fatigue. In one aspect, a carbon-graphene composite compound of arched structures arranged into parallel stacks is used.

[0117] **Figure 7B** is a top view of an illustrative compressible particle **700B** in an alternate embodiment. In this arrangement, the particle **700B** has fewer holes **710**, indicating a lower porosity (or higher density). Again, the particle **700B** may be a carbon-graphene composite.

[0118] With reference again to **Figure 5B**, particles in accordance with particle **700A** and particles in accordance with particle **700B** are used in the carrier fluid **543**. Particles **700A** have a lower relative density and are clustered near the top **546C** of the annulus **542** while particles **700B** have a relatively higher density and settle more readily along the fluid column **543**, extending to the bottom.

[0119] It is noted that the illustrative particles **700A** and **700B** have irregular profiles. The irregular profiles are polygonal, or multi-sided. Particles having a variety of outer diameters, profiles and specific gravities may be employed to prevent excessive packing during pressurization. This enables pressure communication with the entire outer surface of each particle **700A**, **700B**.

[0120] **Figure 7C** is a side view of a coating **700C** that may optionally be used around a compressible particle, such as particle **700A** or **700B**. The coating **700C** may be applied by dipping the particles **700A**, **700B** into a vat containing a liquefied coating material. The

coating material may comprise, for example, natural rubber, synthetic rubber or a thermoplastic elastomer. An example of a thermoplastic elastomer is vinylidene fluoride-hexafluoropropylene co-polymer. The coating will have its own porosity, aiding in the compressibility and buoyancy of the particles **700A**, **700B**.

5 [0121] As an alternative to the coating process, compressible particles **700A**, **700B** may be placed on a screen or tray and passed under a spray of warmed elastomeric coating material. As the particles **700A**, **700B** pass through or under the spray of the warmed elastomeric coating material, the coating **700C** is applied to the compressible particles **700A**, **700B**. The particles **700A**, **700B** are then gently shaken or mixed to ensure that the particles **700A**, **700B** do not
10 adhere to each other as the polymer coating dries. The particles **700A**, **700B** may be passed through a cooling station to congeal the polymeric material, or may be run through a drying station wherein blowers are used to blow air across the compressible particles **700A**, **700B**.

[0122] Returning again to **Figure 6**, the method **600** additionally includes selecting a geometry for the compressible particles. This is seen in **Box 630**. Geometry refers to both
15 shape and size.

[0123] The compressible particles may range in size from 40 μm to 700 μm in diameter, depending on the specific particle size distribution. More preferably, the particle size distribution will be between 100 μm to 700 μm or even between 200 μm to 400 μm .

[0124] Particles having a variety of outer diameters and a variety of specific gravities are
20 preferably employed to prevent packing during pressurization. In one aspect, particles have irregular sides such as shown with particle **700A** are used. In another aspect, particles having different shapes may be employed to prevent packing. For example, some particles may have a circular profile while others may have an oval profile.

[0125] **Figure 8A** is a top view of a compressible particle **800A**. The particle **800A**
25 presents a geometry having a smooth outer surface. In this view, the profile is oval. As an alternative, the profile could be circular.

[0126] **Figure 8B** is a top view of another illustrative compressible particle **800B**. Here,
the particle **800B** has an irregular shape. Particle shape may be adjusted to selectively increase or decrease the degree to which particles “fit together” while undergoing compressive forces
30 downhole.

[0127] **Figure 9A** is a sectional view of a carrier fluid **920**. In this view, a collection **900A**
of compressible particles **910** is suspended in the carrier fluid **920**. Of interest, the illustrative particles **910** share the same shape, each having a polygonal profile. The particles **910** are compressed together due to pressure build-up within a trapped annulus.

[0128] **Figure 9B** is a second illustrative view of a collection **900B** of the compressible particles **910** in a carrier medium **920**. Here, the particles **910** each have a coating **930**. Either the particles themselves **910** or the coating **930** includes an electrical or magnetic charge that causes the particles **910** to repel one another. This inhibits packing of the particles **910** within the wellbore. This also inhibits settling of the particles **910** within the annulus, enabling the particles **910** to remain well dispersed along the fluid column **543** in spite of pressure build-up. Stated another way, the coating **930** mitigates formation of a pressure impenetrable bed after particle settlement.

[0129] The coating **930** may be applied during finishing operations of the collapsible particle manufacturing as to not disrupt the mechanical properties and structure of the particles **910**. The coating **930** may be engineered to ensure compatibility such that interaction of surface coating chemicals and downhole chemicals used in the carrier fluid **920** is not detrimental and so that the coating **930** maintains its utility during lifecycle of particle utilization.

[0130] Engineering the collapsible particle size and shape will allow for buoyancy in the fluid column. Smaller particle size and irregular particle shape with higher surface area will allow for better suspension in the fluid column **543**.

[0131] Returning to **Figure 6**, the method **600** further includes selecting a compressibility response for the compressible particles. This is shown in Box **640**. Compressibility may be measured in terms of volumetric change per pressure change (dV/dP). Preferably, the compressibility response is between 0.5 mm and 1.0 mm / 100 psi. Alternatively, each of the compressible particles has a compressibility of between 14% and 22% (up to 10,000 psi). The particles may also have a resiliency of between 87% and 117%.

[0132] **Figure 10A** is a Cartesian chart **1000A** showing compressibility of a particle. Compressibility is indicated along the y -axis as a percentage of volumetric change, while pressure (measured in psi) is shown on the x -axis. Line **1000** demonstrates a compressibility response of a particle as pressure increases. To maximize the effectiveness of compressible particles, the pressure acting on those particles ideally would be within the area of a compressibility curve that maximizes the volumetric change per pressure change (dV/dP). In **Figure 10A**, this resides within P_A and P_B .

[0133] The compressible particles, when suspended in a carrier fluid, should be placed within the annulus such that the predicted pressure P at the position of placement is within the maximum dV/dP capabilities of the particle. This would be within the range between P_a and P_b . P_a would be the initial pressure state of the annulus before the annulus builds up pressure.

P_b represents a final pressure state of the annulus after productions operations have commenced and the wellbore has warmed.

[0134] The depth of this pressure range $P_a - P_b$ can be found by calculating the expected pressure profile within the annulus. The end result of this is that compressible particles 546 are placed to maximize the effectiveness of their compressibility response.

[0135] **Figure 10B** is a graph **1000B** showing a pressure profile within the annular region of a wellbore. Vertical depth within the annulus is shown on the y -axis, measured in feet, while pressure in the annulus is shown on the x -axis, measured in psi. Once again, the pressure values P_A and P_B are indicated, meaning pressure both before and after pressure build-up.

10 [0136] Two different depths are shown in **Figure 10B**, referenced as **Depth 1** and **Depth 2**. **Depth 1** indicates an upper portion of a trapped annulus while **Depth 2** indicates a lower portion of a trapped annulus. **Depth 2** is obviously lower than **Depth 1**.

[0137] As depth within the annulus increases, the pressure increases. This suggests that the depth of particle placement should be tuned to maximize the compressibility response of the particles. Thus, particles with a higher degree of compressibility should be placed closer to **Depth 1** while particles with a lower degree of compressibility should be placed closer to **Depth 2**.

15 [0138] As an aside, where screens (such as screen **230**) are used, the operator may choose to place particles having a higher degree of compressibility in screens residing at shallower locations along the wellbore. Reciprocally, the operator may choose to place particles having a lower degree of compressibility in screens residing along joints that are at or deeper locations along the wellbore.

[0139] Where the filter screens are not used, the operator may use staged fluid displacements to place particles having different compressibilities along the annular region. This means that the operator will pump down carrier fluid carrying particles having a higher degree of compressibility first, followed by particles having a slightly lower degree of compressibility second, followed still by particles having an even lower degree of compressibility third, and so forth. Preferably, no more than three stages would be employed.

25 [0140] As another option, the particles may have different densities, corresponding to their compressibility responses. Some particles will have a lower density and a higher compressibility response. Still others will have a slightly lower density and a slightly higher compressibility response. At the same time, some particles will have the highest density and the lowest compressibility response. All of these particles may be mixed together (shown at Box **650**) before pumping.

[0141] Once the carrier fluid 543 is placed within the annulus 542, some re-settling of particles 546 will take place. Particles 546 having the lowest density will slowly rise to the top of the column 543 while particles 546 having the highest density will slowly settle towards the bottom.

5 [0142] In one aspect, particles having higher degrees of compressibility will be designed with a lower density. Similarly, particles having lower degrees of compressibility will be designed to have a higher density. In this way, all compressible particles may be pumped into the annular region together ahead of a cement slurry, with the understanding that the particles will at least partially re-settle themselves according to their respective densities. Density may
10 be adjusted, for example, by increasing or decreasing porosity.

[0143] As a third option, the operator may choose to deliberately place particles within an annular region 542 in stages. Particles 546 with a lower density and a higher compressibility response will be pumped down first. This would be followed by particles 546 with a slightly lower density and a slightly higher compressibility response. Particles 546 having the highest
15 density and the lowest compressibility response would be pumped down last, just ahead of the cement. In this arrangement, two to five stages of fluid displacement may be employed.

[0144] In any instance, where a carrier medium 543 carrying compressible particles 546 is pumped down a wellbore (such as wellbore 500B), the operator will need to mix the particles into the fluid first. This is provided at Box 650. Preferably, the compressible particles 546 are
20 mixed into the fluid 542 at a concentration of 5% to 40% by volume. The greater the concentration of particles there is, the greater the overall compressibility the fluid column 920 will have. Thus, overall compressibility is impacted not only by the degree of compressibility of the particles along the column 543, but also by the number of particles 546 provided.

[0145] In connection with the mixing step of Box 650, the operator may choose to add
25 additives to the mixture in order to increase the rheological properties (e.g., plastic viscosity, yield point value, and gel strength) of the mixture. Such additives may include one or more natural and/or synthetic polymeric additives, polymeric thinners or flocculants. The purpose of such additives is to alter the gel strength of the fluid 542 to inhibit particle settling.

[0146] Alternatively, the operator may provide an electric or magnetic charge to the
30 particles to keep them suspended. Alternatively still, the particles may be coated with a material having an electrical or magnetic charge to inhibit settling. Such an arrangement is shown in Figure 9B discussed above.

[0147] It is observed here that the presence of gas in the carrier fluid 543 can inhibit the performance of the compressible particles 546. To improve the performance of the

compressible particles **546**, the carrier fluid **543** may be prepared such that the gas content is minimized. Thus, a step **660** of de-gasifying the mixture may be provided for the method **600**.

[0148] One option for reducing gas content is through mechanical agitation or stirring. For example, the motor and impeller of a known “gas trap” apparatus may be employed. An
5 example of such a gas trap is the Floatair[®] gas trap available from Floatair LLC of Carlsbad, New Mexico. Details concerning this gas trap are presented in U.S. Patent No. 9,879,489, and are incorporated herein by reference. The gas trap may be floatably placed within a mixing tank, causing vapors to escape through the top of a mixing canister.

[0149] As another option, the mixture may be carried from a mixing tank that is held under
10 pressure to a holding tank having less pressure, such as an open air tank. To aid in degasification, sonic energy may be applied to agitate the mixture through pulses that drive the gas out. For example, a mega-sonic energy transducer that generates between 900 kHz and 2.0 MHz may be used.

[0150] Alternatively or in addition, a hold time could be applied to the mixture before
15 pumping into the wellbore in order to allow gases to come out of solution at ambient conditions. Additionally, gas content in the carrier fluid **543** may be reduced by applying a reductant, or reducing agent.

[0151] Referring back to **Figure 6**, the method **600** may also optionally include adjusting
20 particle density to compensate for the presence of a weighting agent. This is indicated at Box **670**.

[0152] Those of ordinary skill in the art will understand that during the drilling of a wellbore, a weighting agent is typically used as part of the drilling fluid. The weighting agent increases the density of the fluid and, thereby, increases the hydrostatic head acting down on the drill bit and the surrounding formation as the drill bit rotates and penetrates downhole. The
25 weighting agent helps act against high formation pressures that may “kick” into the wellbore. The weighting agent also forms a “cake” against the wellbore wall to prevent fluid loss during circulation.

[0153] Commonly-used weighting agents include barite and hematite. Weighting agent particles will remain in the wellbore after casing strings are run into the hole. This means that
30 as the fluid mixture (that is, the carrier fluid **543** with compressible particles **546**) is pumped downhole, the mixture will likely pick up weighting agent particles en route to the annular area **542**. This will affect the buoyancy of the compressible particles **546**.

[0154] **Figure 11A** is an illustrative view of an annular region **1100**. The annular region **1100** represents a small portion of an annular fluid column for a wellbore, such as the column

543 of **Figure 5A**. The annular region **1100** holds a plurality of compressible particles **1110**. The particles **1110** are suspended in an aqueous carrier fluid **1120**. The compressible (or collapsible) particles **1110** are designed to have a density that is lower than (or very close to) the density of the fluid **1120**, thereby enabling buoyancy.

5 **[0155]** In the column **1100** of **Figure 11A**, weighting agent particles **1130** can also be seen. Due to their weight, most of the particles **1130** have settled towards the bottom of the column **1100**. At the same time, some of the weighting agent particles **1130** have attached themselves to the compressible particles **1110**, causing the compressible particles **1110** to also sink towards the bottom of the column **1100**. The weighting agent **1130** may be any weighting agent known to be used in drilling mud, such as barite or hematite.

10 **[0156]** To avoid this scenario, the density of the particles **1110** can be engineered and adjusted. **Figure 11B** is an enlarged view of one of the particles **1110** from **Figure 8A**. It can be seen that the collapsible particle **1110** is designed to be about 100 times larger in size compared to the weighting agent particles **1130**. The large difference in the particle size between the compressible particles **1110** and the weighting agent particles **1130** reduces the amount of drag/sag during solids settlement, and reduces the concentration of the compressible particles **1110** in the annular fluid **1120**.

15 **[0157]** In some instances, the presence of the weighting agent particles **1130** is beneficial, particularly for compressible particles **1110** that have lower compressibility. In this case it is desirable for the particles **1110** to settle lower along the column **543**. A weighting agent will help keep the particles within the desired range of depth for maximum compressibility as discussed above in connection with **Figure 10B**, that is, between **Depths 1** and **2**.

20 **[0158]** For particles with a higher compressibility, a lower density can be achieved by designing the larger particles **1110** to have increased pore volume. In this way, the particles **1110** stay buoyant in the fluid **1120** even in the presence of weighting agent **1130** particles. The density of the collapsible particles **1110** should be lower than that of the weighting agent particles **1130**. The collapsible particles **1110** may also be designed to have limited affinity to the weighting agent particles **1130**.

25 **[0159]** This issue of drag caused by the weighting agent particles **1130** can be further mitigated by applying a coating (shown at **700C** in **Figure 7C**) to the particles **1110**. The coating **700C** will serve as a wetting agent or enhanced particle disperser. Collapsible particle clogging/conglomeration is thereby reduced in low flow through and suspension volume areas. The use of a coating **700C** may also increase uniformity in compressible particle distribution in suspension operations. Increased distribution of collapsible particles **1110** through the

annulus **542** would not significantly increase kinetic energy, temperature build, or pressure build.

[0160] It is again observed that if the particles **1110** cannot be suspended in the annular fluid, the particles will either settle down in the column **1100** or settle (or float) up in the column **1100**, depending on the relative specific gravities of the fluid **1120** versus the compressible particles **1110**. Settling down results in a state where the weight of the particles **1110** is pulling the bed into a more compacted state. Settling up results in a situation where the weight of the particles **1110** is pushing the bed into a less compacted state. This results in a higher likelihood of pressure penetration from one side of the particle bed to the other side of the particle bed.

[0161] The operator may therefore prefer a configuration where a bed of particles **546** is used that intentionally floats to the top of the annulus **542**. For this, the particle density can be engineered to ensure it is buoyant in the carrier fluid **543**. For example, this can be achieved by modifications to particle shape, size, porosity, morphology, texture, and material.

[0162] **Figure 5C** is another perspective view of the upper portion of a wellbore **500C**. In this instance, a column of carrier fluid **543** holding compressible particles **546** is again placed in the unfilled annular space **542** (or trapped annulus) around an intermediate string of casing **540**. The compressible particles **546** are dispersed along the fluid column **543**. However, in this view the concentration of particles **546** is greater along an upper portion **546C** of the column of carrier fluid **543**.

[0163] Placing a majority of the compressible particles **546** at or near the upper end of a trapped annulus **542** allows the column of fluid **543** within the trapped annulus **542** to expand upward against the compressible particles **546**. This results in a higher probability that the pressure will migrate through the bed **543**, maximizing the amount of particles **546** that are compressed.

[0164] It is observed from **Figure 5C** that once the compressible particles **546** rise to the top of the column **543**, any weighting agent particles (shown at **1130** in **Figures 11A** and **11B**) will settle out below the compressible particles **546**. In some instances, weighting agent particles **1130** will settle to the bottom as demonstrated in **Figure 11A**. A small fraction of the lighter, collapsible particles **546** (or **1110** as shown in **Figure 11A**) are also pulled down with the barite particles **1130** to form a compacted bed with the barite particles **1130**. In between is a dispersion of compressible particles **546**, a small portion of which will have weighting agent particles **1130** adhered thereto and surrounding it.

[0165] The difference in size, shape, particle morphology and density between the barite and collapsible/compressible particles is such that fluid pressure can still reach up through the column **543** and to the compressible particle **546** at the top even after solid settlement in the lower regime in the fluid column **543**.

5 [0166] With respect to each of **Figures 5B** and **5C**, it is noted that each of areas **532** and **552** is also a trapped annulus. However, these annuli **532**, **552** are not shown as having compressible particles **546**. The operator may add compressible particles in these annuli **532**, **552** using the method **600** described in **Figure 6**. On this note, **Figure 6** finally includes the step of pumping the mixture (that is, the carrier fluid with suspended compressible particles)
10 into a wellbore annulus. This is seen in Box **680**. The carrier fluid is pumped in ahead of the cement column.

[0167] As can be seen, an improved tubular body having a filter screen is provided. The filter screen holds compressible particles closely along an outer diameter of the tubular body. These particles, again, volumetrically compress as the pressure increases in the annulus,
15 resulting in additional volume into which the annular fluid can expand.

[0168] A method of using the tubular body as part of a method of alleviating pressure within a trapped annulus is also provided. The method involves the placement of filter screens along selected locations within an annular column.

[0169] As a related invention herein, improved methods for alleviating pressure within a
20 trapped annulus are provided. The methods involve the placement of collapsible particles along the annular column at selected locations. The particles volumetrically compress as the pressure increases in the annulus, resulting in additional volume into which the annular fluid can expand. Engineering the pore volume/ porosity level within the particles to allow for buoyancy in the fluid column (a) increased pore volume to ensure particle stays buoyant (b)
25 identical particle size but lower porosity results in reduced buoyancy.

[0170] A method of placing particles within a wellbore is provided. The particles are designed to volumetrically compress as pressure increases in a confined volume such as a trapped annulus, thereby mitigating detrimental effects due to latent pressure increases upon the wellbore tubulars forming the annulus. For example, as a well begins producing
30 hot fluids from deep production zones, the hot fluids may increase the pressure within the tubing, which in turn can heat the casing surrounding the tubing. These temperature increases may result in increases in annular pressure. While land-based wellheads can provide means for bleeding off the pressure increases, subsea wellheads typically do not provide means for bleeding pressure increases. The consequence of this can be collapse or

burst of wellbore tubulars. The mitigating compressibility and resilience of the particles serves to prevent the pressure from increasing as much as it otherwise would without the compressible particles being placed in the annulus. The compressibility results in additional compressible volume into which the annular fluid can expand, at pressures below
5 the damage point of the tubulars.

[0171] A useful method for mitigating pressure increases within a wellbore is provided that includes placing compressible particles within an annular area of a wellbore that includes a first string of casing positioned within an upper portion (meaning, closer to the well surface) of the wellbore and a second string of casing extending within at least a
10 portion of the first string of casing and into an extended portion (meaning further downhole with respect to the surface region of the wellbore) of the wellbore below (meaning further downhole with respect to the surface region) the first string of casing. The first string of casing surrounds an overlapped portion of the second string of casing, thereby creating a fluid-filled annulus between first string of casing and the overlapped portion of the second
15 string of casing. The annular volume may also include the volume between the second string of casing and the formation adjacent the extended portion of the wellbore.

[0172] The concentration of the compressible particles are dispersed in a fluid mixture that comprises a carrier fluid (either an aqueous or hydrocarbon based liquid that does not promote premature degradation of the particulates) and a concentration of compressible
20 particles dispersed in the carrier fluid. The “concentration” generally refers to a determined weight or volume of the particulates within the carrier fluid, but does not require a specifically determined concentration value. A plurality or dispersion of particles is also suitable. The carrier fluid may include other components such as corrosion inhibitors, gel, viscosifying agents, etc. The concentration of the compressible particles may be
25 determined by volume or weight, and will vary depending upon the compressibility of the particles, the pressures anticipated within the wellbore, expected tubular volume change, permissible tubular pressure range, and projected annular volume expansion. Exemplary concentrations of mineral-based particulates, such as graphitic or carbon based compositions, without limitation, may be for example, from 1 pound per barrel (ppb) of
30 carrier fluid to 125 ppb, or 1 ppb to 100 ppb, or 1 ppb to 50 ppb, or 1 ppb to 25 ppb, or 1 ppb to 10 ppb. Suitable concentrations of polymeric compositions may be proportionately lower with respect to their lower bulk density or specific gravity as compared to the mineral-based particulates. Lab testing under projected annular conditions is recommended to ascertain the desired particulate concentration and performance factors. Some wellbore

annular tubular combinations and/or production temperature conditions may require substantial protection from pressure increases and corresponding substantial deformation and/or resiliency, while others may only require a nominal amount of protection.

[0173] The concentration may be considered a plurality of particles, as the desired
5 particles should remain individually granular particulates when subjected to pressures of up to 10,000 psig, without packing or losing granularity. It is preferred that the particles remain as distinct particles over when indefinitely subjected to pressure of up to 10,000 psig at maximum expected wellbore temperature. Resiliency is the ability of the particulate particles to absorb energy by volumetrically compressing, and then upon release of the
10 energy to recover a percentage of the lost volume. The claimed particles must not only compress under increasing pressure, but they also must be able to recover at least 50% of the compressed volume upon release of that pressure. The volume recovery is the resiliency. It is the volume recovery that is important in the annulus fluid mixture, because over its life, a trapped annulus will experience numerous pressure (and thermal) changes
15 due to changes in production activity, shut-in periods, stimulation, well treatments, etc. Particulates that merely compress without sufficient recovery (resilience or elastic expansion) are not useful for pressure compensation purpose over the life of the well. An ideal recovery would be 100% by volume.

[0174] What is suitable for the present technology is a compressible particulate
20 concentration that, after initial placement in the wellbore, can volumetrically compress or deform (e.g., compress, elongate, flatten, pack together, shrink in bulk diameter, and/or otherwise change in bulk volume for the plurality of particulates) by at least 10% by volume, or at least 20%, or at least 50% in response to further increased applied pressure after placement in the annulus, that is, as compared to their volume in the annulus
25 immediately after placement therein, even if them somewhat compressed. Stated differently, although the compressible particles may compress somewhat in response to their initial pumping and placement in the wellbore, such as in conjunction with a cementing job, wherein they experience an initial hydrostatic pressure profile within the annulus, it is the further or subsequent compression that is relevant for the particles
30 performing their intended function in the annulus. That further or subsequent compression may be due to any of a number of operational factors such as thermal heating due to production operations. Thereafter, the particles should be able to recover at least 50% of that further, or subsequent compression (deformation).

[0175] The important compressibility and resilience feature that is key is the ability to further compress after initial placement in the wellbore. Initial placement in the wellbore refer to the time when the particles are first pumped into the wellbore annulus and pumping is ceased such that the fluid mixture with the particles is generally at its intended location, such as at the end of pumping cement and displacing the wiper plug, before cement sets up. The further important function of the particles is their ability to then resiliently recover from that additional deformation or compression that happened subsequent to initial annular placement. The particles should be able to further compress by at least 10% by volume, or at least 20%, or at least 50% in response to the subsequently applied pressure (subsequent to initial placement in the annulus). This subsequent or further pressure increase may be caused by wellbore activities or events as described previously herein, such as production of hot produced fluids through the wellbore.

[0176] Thereafter, when the applied fluid pressure is removed or reduced, the particles resiliently recover and reform or expand back volumetrically by at least 50%, or at least 60%, or at least 70%, or at least 100%, or even at least 110%, with respect to the volume of the particulates in the annulus immediately after placement, prior to the subsequent application of the pressure in the annulus. Preferred particles will be able to effectively repeat this cycle many times. The ability of the particles to reform by at least 50% is desirable, more than 60% more desirable, and by at least 80% even more desirable. Recovery of 100% is ideal, but many particulate materials will likely experience at least some mild degree of hysteresis, such as some fluid permeation into a few of the pores of some portions of some of the particulates. The feature of recovery or expanding back after removal of the pressure increase is preferably an elastic strain recovery. The concept of recovery is referred to herein as resilience.

[0177] Thereby, the compressible particulates are useful for compensating for subsequent, repeated pressure increases according to their intended purpose, over a desired life-range in the wellbore annulus. From a stress-strain perspective, it is desirable that the volume changes due to pressure increases of up to 10,000 psig can be repeatedly applied, even if not to the same degree as for previous volume changes. The preferred particles exhibit at least 10% of resiliency, by volume. As for particulate dispersion or distribution within the annulus, it is not required that the particulates remain evenly or otherwise distributed over the length of the wellbore annulus. The particulates may, over time, accumulate in a lower region of the annular area, due to gravitational deposition. So long as the desired, overall compressibility and recovery or resilience of the plurality of

particulates provides the desired amount of resiliency or recovery, then accumulation in the lower portion of the wellbore should not be detrimental. However, if the accumulation in the lower portion of the wellbore becomes excessive to the point that the particulates within the lower portion of the packed volume do not experience the pressure increase, then care should be considered to determine whether the carrier fluid should have some gel or particulate-suspending properties that will keep the particulates suspended in a fashion that will permit sufficient volume of the particulates to pressure exposure and contribute to the desired pressure compensation in the annulus.

[0178] Further variations of the tubular body and of the method of mitigating pressure within a trapped annulus herein may fall within the spirit of the claims, below. It will be appreciated that the inventions are susceptible to modification, variation and change without departing from the spirit thereof.

Industrial Applicability

[0179] The systems and methods disclosed herein are applicable to the oil and gas industries.

[0180] It is believed that the disclosure set forth above encompasses multiple distinct inventions with independent utility. While each of these inventions has been disclosed in its preferred form, the specific embodiments thereof as disclosed and illustrated herein are not to be considered in a limiting sense as numerous variations are possible. The subject matter of the inventions includes all novel and non-obvious combinations and subcombinations of the various elements, features, functions, and/or properties disclosed herein. Similarly, where the claims recite "a" or "a first" element or the equivalent thereof, such claims should be understood to include incorporation of one or more such elements, neither requiring nor excluding two or more such elements.

[0181] It is believed that the following claims particularly point out certain combinations and subcombinations that are directed to one of the disclosed inventions and are novel and non-obvious. Inventions embodied in other combinations and subcombinations of features, functions, elements, and/or properties may be claimed through amendment of the present claims or presentation of new claims in this or a related application. Such amended or new claims, whether they are directed to a different invention or directed to the same invention, whether different, broader, narrower, or equal in scope to the original claims, are also regarded as included within the subject matter of the inventions of the present disclosure.

CLAIMS

What is claimed is:

1. A tubular body for a wellbore, comprising:
 - an elongated pipe body having a box end and a pin end, the pipe body defining a wall
 - 5 fabricated from steel or ceramic and having an outer diameter;
 - a filter screen disposed around the outer diameter of the wall along at least a portion of the elongated pipe body, the filter screen defining a cylindrical body having a first end and an opposing second end, and one or more slots along the body; and
 - a plurality of compressible particles residing within the filter screen, wherein each of
 - 10 the compressible particles is fabricated to collapse in response to fluid pressure communicated through the slots in the filter screen;
2. The tubular body of claim 1, wherein each of the compressible particles has a compressibility of between 10% and 30%, up to 10,000 psi.
3. The tubular body of claim 1, wherein:
 - 15 each of the one or more slots is between 10 μm and 100 μm in diameter;
 - the compressible particles have a range of outer diameter that is from 10 μm to 700 μm (in dry state); and
 - at least 50% of the compressible particles have a range of outer diameter that is from 50 μm to 600 μm .
- 20 4. The tubular body of any of claims 1-3, wherein:
 - the compressible particles have an average porosity of between 10% and 40%;
 - each of the particles has a resiliency of between 80% and 120%;
 - each of the compressible particles has a compressibility of between 14% and 27%, up
 - to 10,000 psi;
 - 25 the average size of each of the compressible particles is between 200 μm and 400 μm (in dry state);
 - each of the particles has a density between 12.0 ppg and 12.8 ppg, inclusive; and
 - each of the particles has a resiliency of between 87% and 117%, inclusive.
5. The tubular body of any of claims 1-4, wherein each of the compressible particles
- 30 comprises carbon.
6. The tubular body of any of claims 1-5, wherein each of the compressible particles comprises a porous graphite carbon (PGC) material.
7. The tubular body of any of claims 1-5, wherein each of the compressible particles comprises graphene beads.

8. The tubular body of any of claims 1-5, wherein each of the compressible particles comprises pore channels coated with natural rubber or a polymer serving as a synthetic rubber.
9. The tubular body of any of claims 1-4, wherein each of the compressible particles comprises a polymeric material.
- 5 10. The tubular body of claim 9, wherein the polymeric material is (i) polystyrene, (ii) styrofoam, (iii) a co-polymer of methylmethacrylate and acrylonitrile, or (iv) combinations thereof.
11. The tubular body of claim 9, wherein the polymeric material comprises neoprene, polyurethane rubber, vinyl, nitrile rubber, butyl rubber, EPDM rubber, silicone rubber, or
10 combinations thereof.
12. The tubular body of any of claims 1-11, wherein:
the filter screen is fabricated from a metal alloy or ceramic; and
the filter screen is secured to the elongated body by welding or by a friction fit.
13. The tubular body of any of claims 1-11, wherein:
15 the filter screen comprises a permeable polymeric material; and
the one or more slots comprises micro-pores in the polymeric material.
14. A wellbore, comprising:
a first string of casing;
a second string of casing, wherein the first string of casing surrounds an upper portion
20 of the first string of casing, forming a trapped annulus;
at least one tubular body placed in series along the first string of casing adjacent the trapped annulus, the at least one tubular body comprising:
an elongated body having a box end and a pin end, and a wall forming
an outer diameter;
25 a filter screen disposed around the outer diameter of the wall along at least a portion of the elongated body, the filter screen defining a cylindrical body having a first end and an opposing second end, and a plurality of slots there along; and
a plurality of compressible particles residing within the filter screen
30 between the first and second ends, wherein each of the compressible particles is fabricated to collapse in response to fluid pressure communicated through the slots of the filter screen during production operations.
15. The wellbore of claim 14, wherein:
the filter screen is fabricated from metal alloy or ceramic;

each of the compressible particles has a compressibility of between 14% and 27%, up to 10,000 psi;

the average size of each of the compressible particles is 200 μm to 400 μm (in dry state); and

5 each of the particles has a resiliency of between 87% and 117%.

16. A method of mitigating pressure within a trapped annulus, comprising:

forming a wellbore;

placing a first string of casing within the wellbore;

10 placing a second string of casing within the wellbore, wherein the first string of casing surrounds an upper portion of the second string of casing, forming an annular area;

placing at least one tubular body along the second string of casing adjacent the annular area, the at least one tubular body comprising:

an elongated body having a box end and a pin end, and a wall forming an outer diameter;

15 a filter screen disposed around the outer diameter of the wall along at least a portion of the elongated body, the filter screen defining a cylindrical body having a first end and an opposing second end and a plurality of slots there along; and

20 a plurality of compressible particles residing within the filter screen between the first and second ends, wherein each of the compressible particles is fabricated to collapse in response to fluid pressure communicated through the filter screen during production operations.

17. The method of claim 16, further comprising:

25 placing a wellhead over the wellbore, thereby forming a trapped annulus in the annular area.

18. The method of claim 17, wherein:

the filter screen is fabricated from metal alloy or ceramic;

each of the compressible particles comprises carbon; and

the method further includes:

30 producing hydrocarbons from a subsurface formation up the wellbore; and

using the compressible particles, absorbing at least a portion of pressure that builds in the trapped annulus during the producing.

19. The method of claim 18, further comprising:

locating the tubular body with filter screen central to the trapped annulus or near a top of the trapped annulus.

20. The method of claim 18, wherein the at least one tubular body comprises a first tubular body located near a bottom of the trapped annulus and a second tubular body located near a
5 top of the trapped annulus.

21. The method of claim 20, wherein the compressible particles in the second tubular body have a higher degree of compressibility than the compressible particles in the first tubular body wherein the filter screen is in the form of a slotted metal tubular or a wire-wrapped screen.

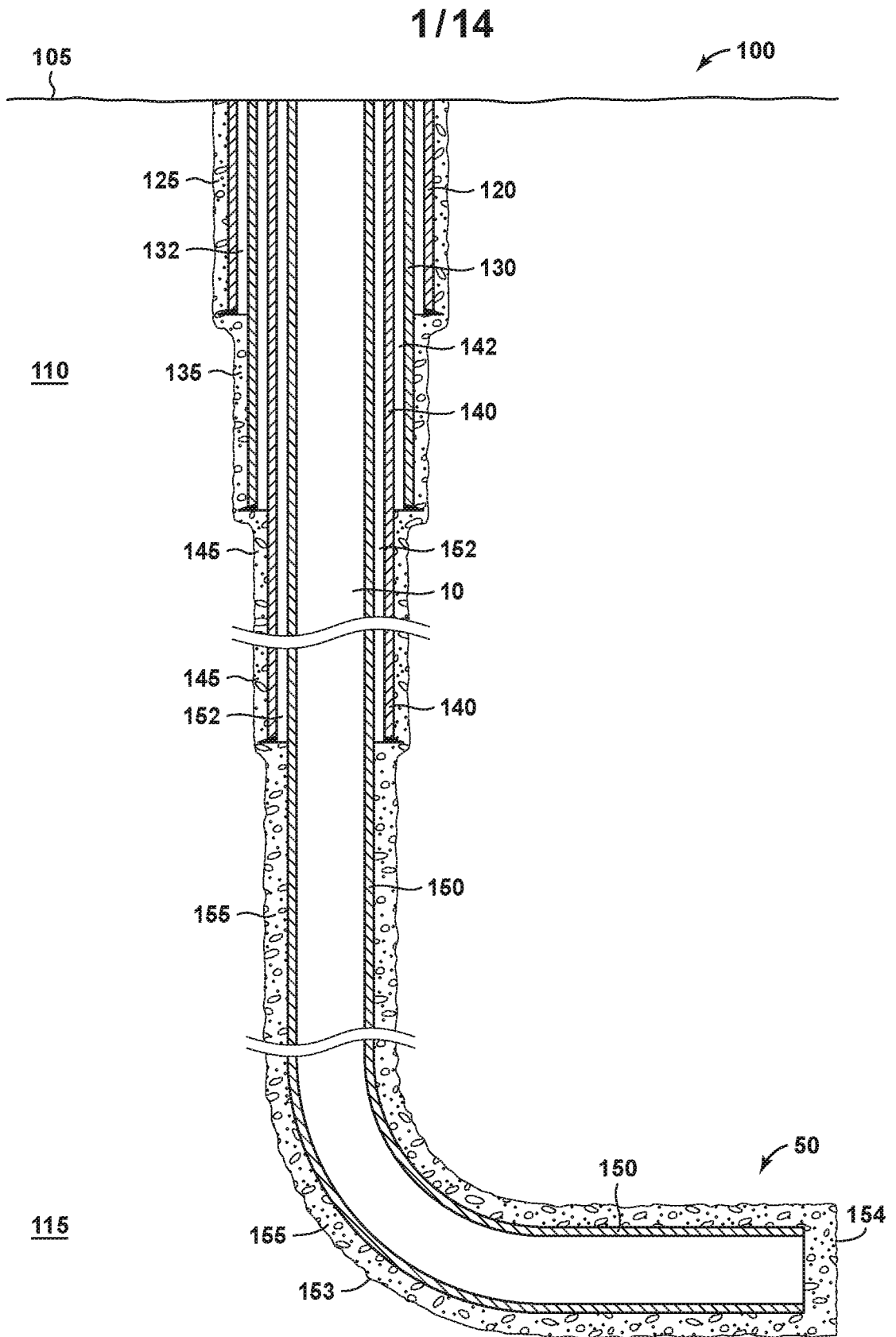

FIG. 1A
(Prior Art)

2/14

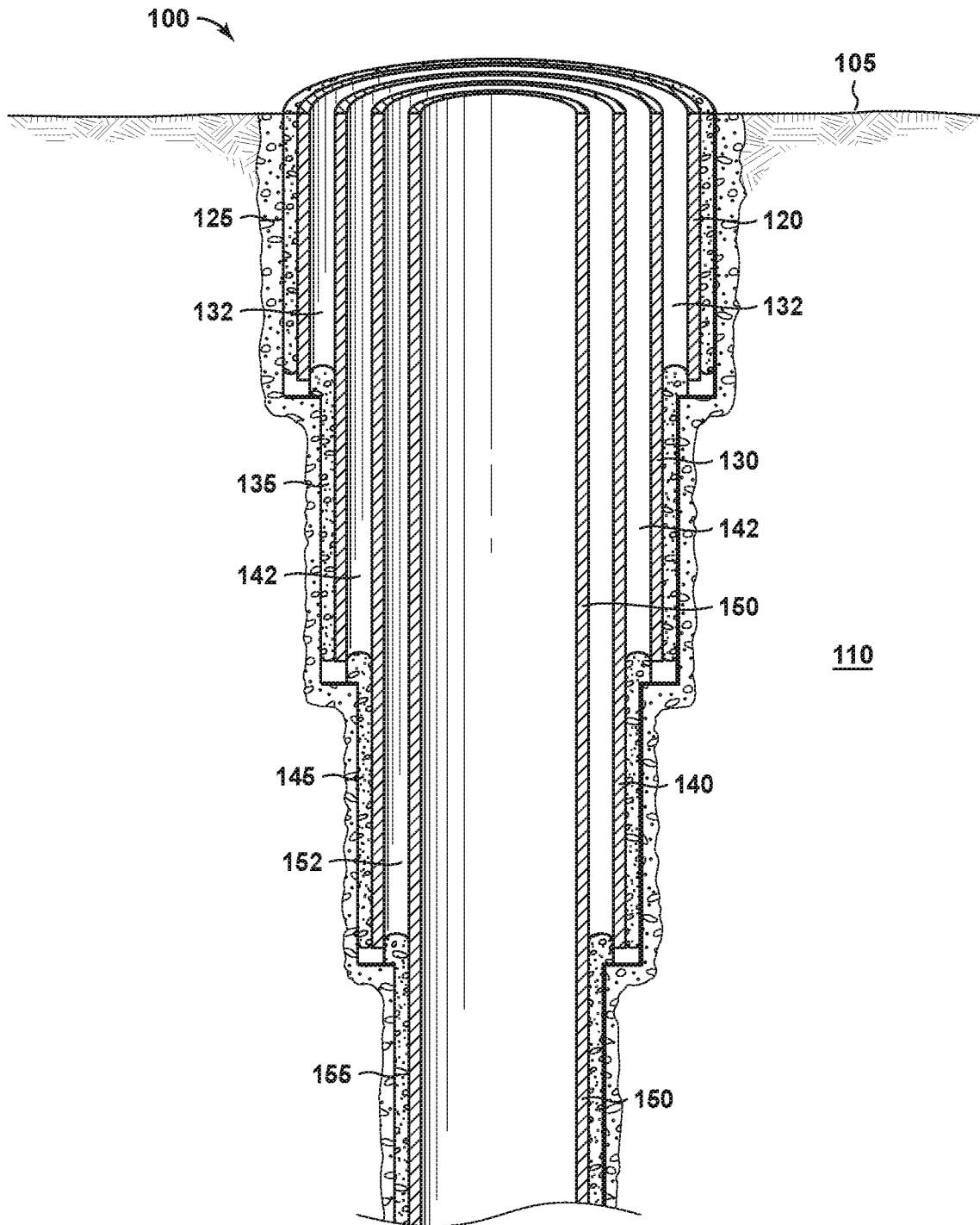

FIG. 1B
(Prior Art)

3/14

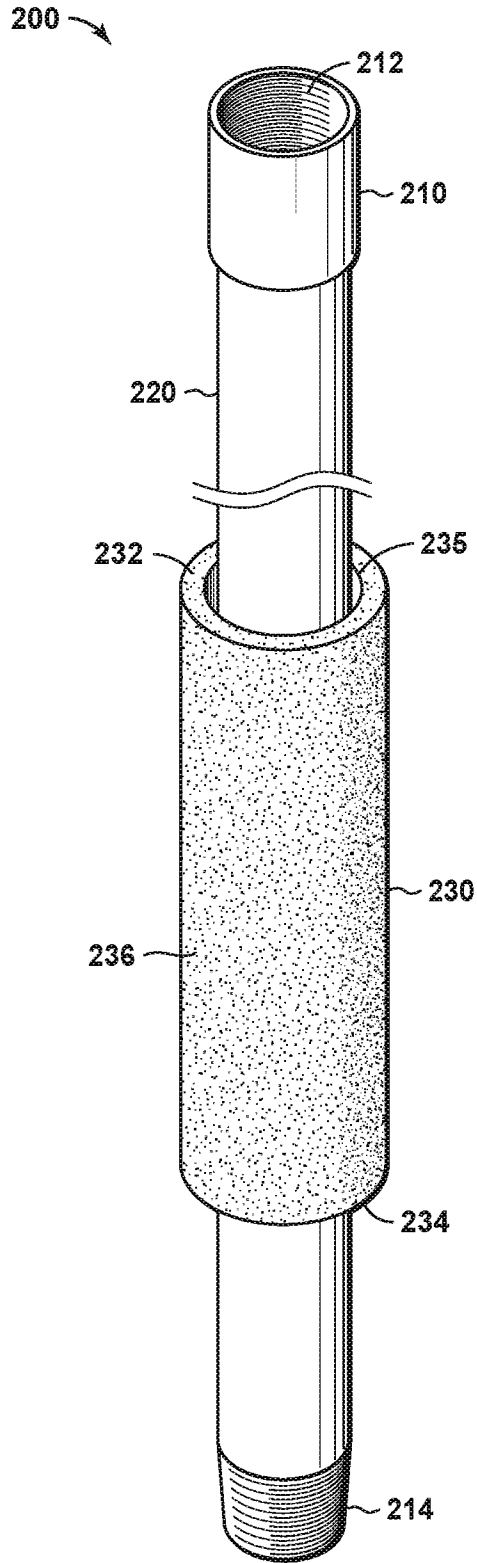

FIG. 2A

4/14

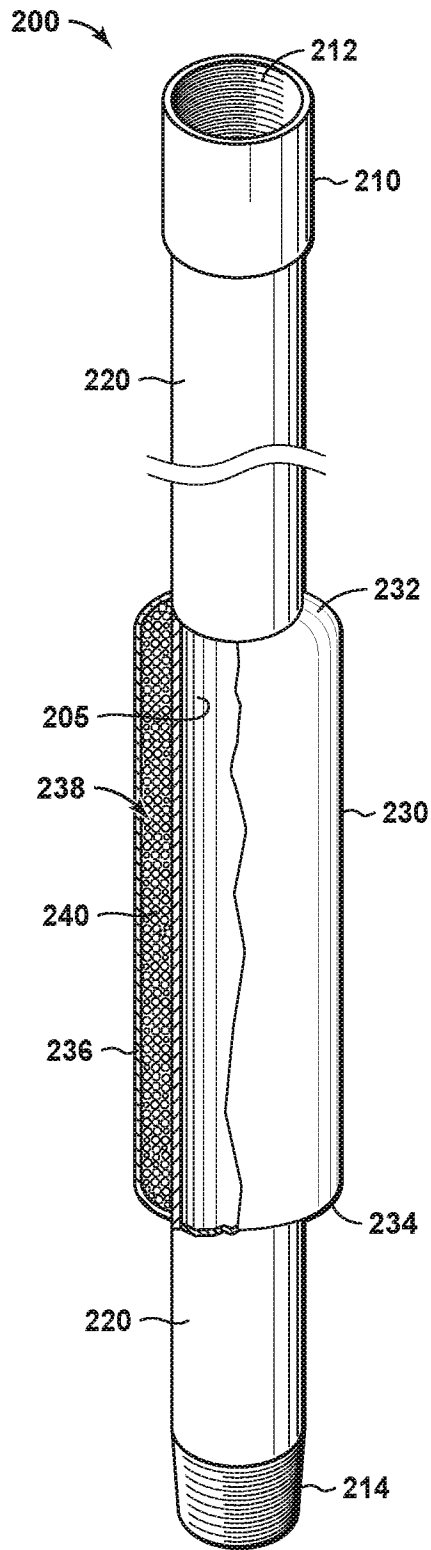

FIG. 2B

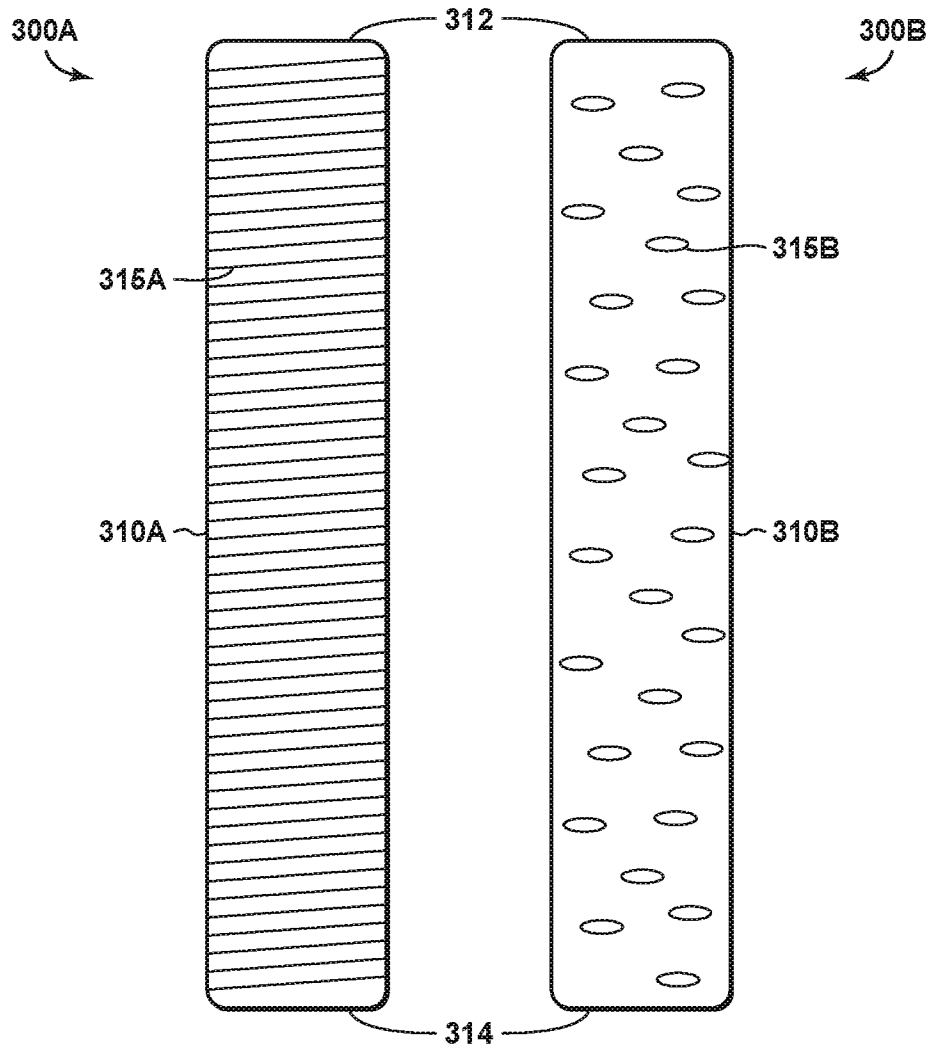

FIG. 3A

FIG. 3B

7/14

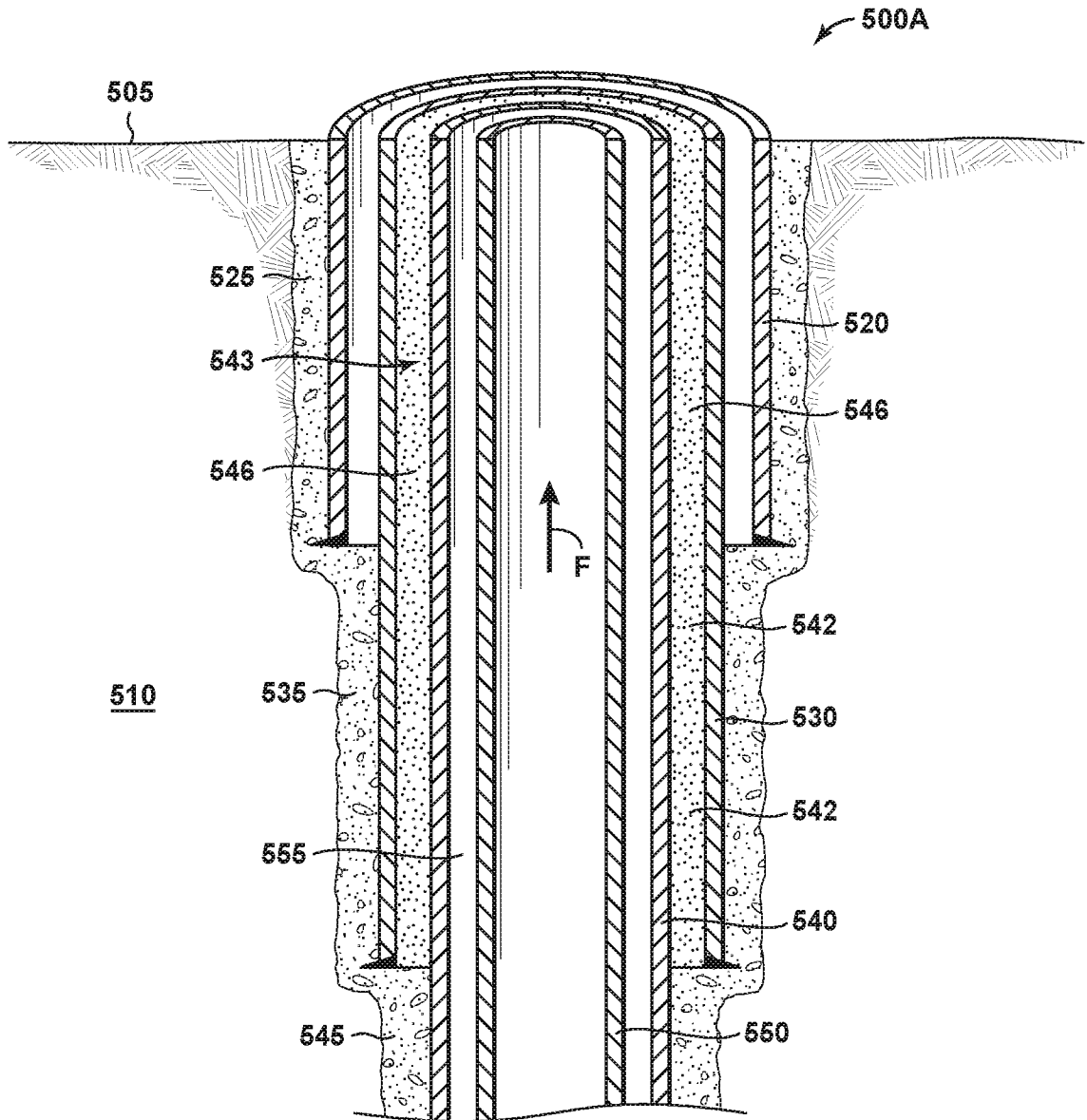

FIG. 5A

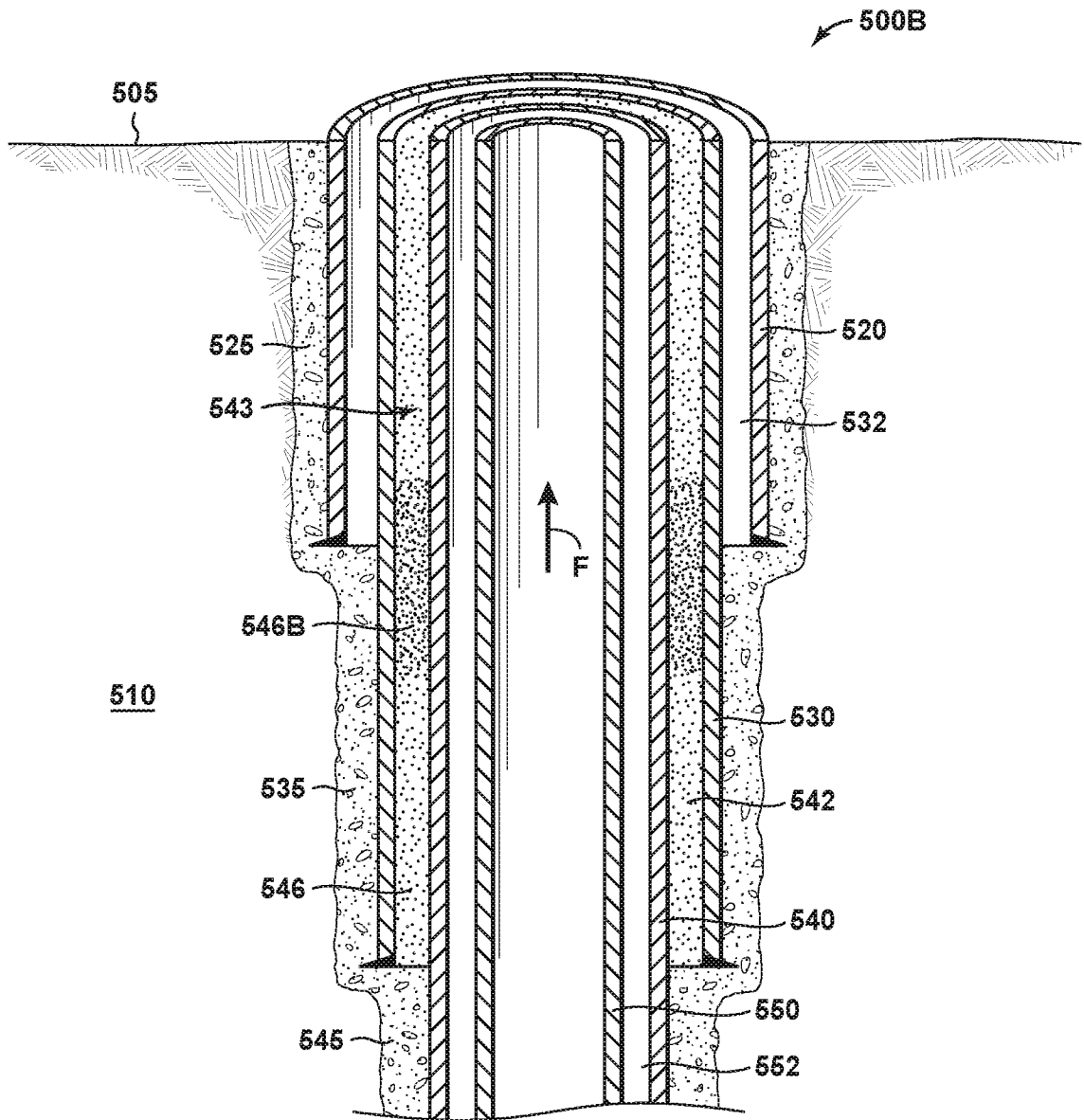

FIG. 5B

9/14

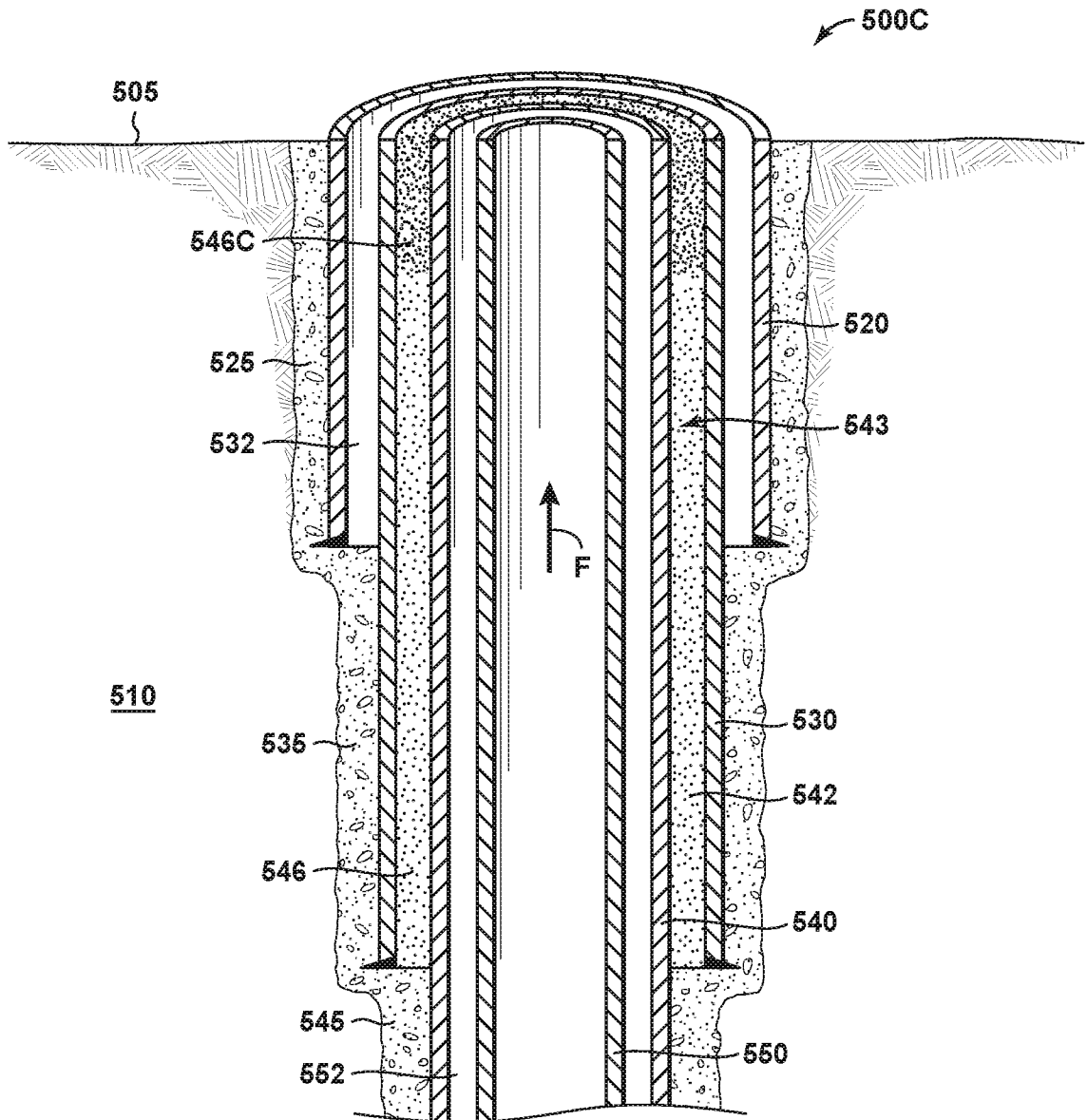

FIG. 5C

10/14

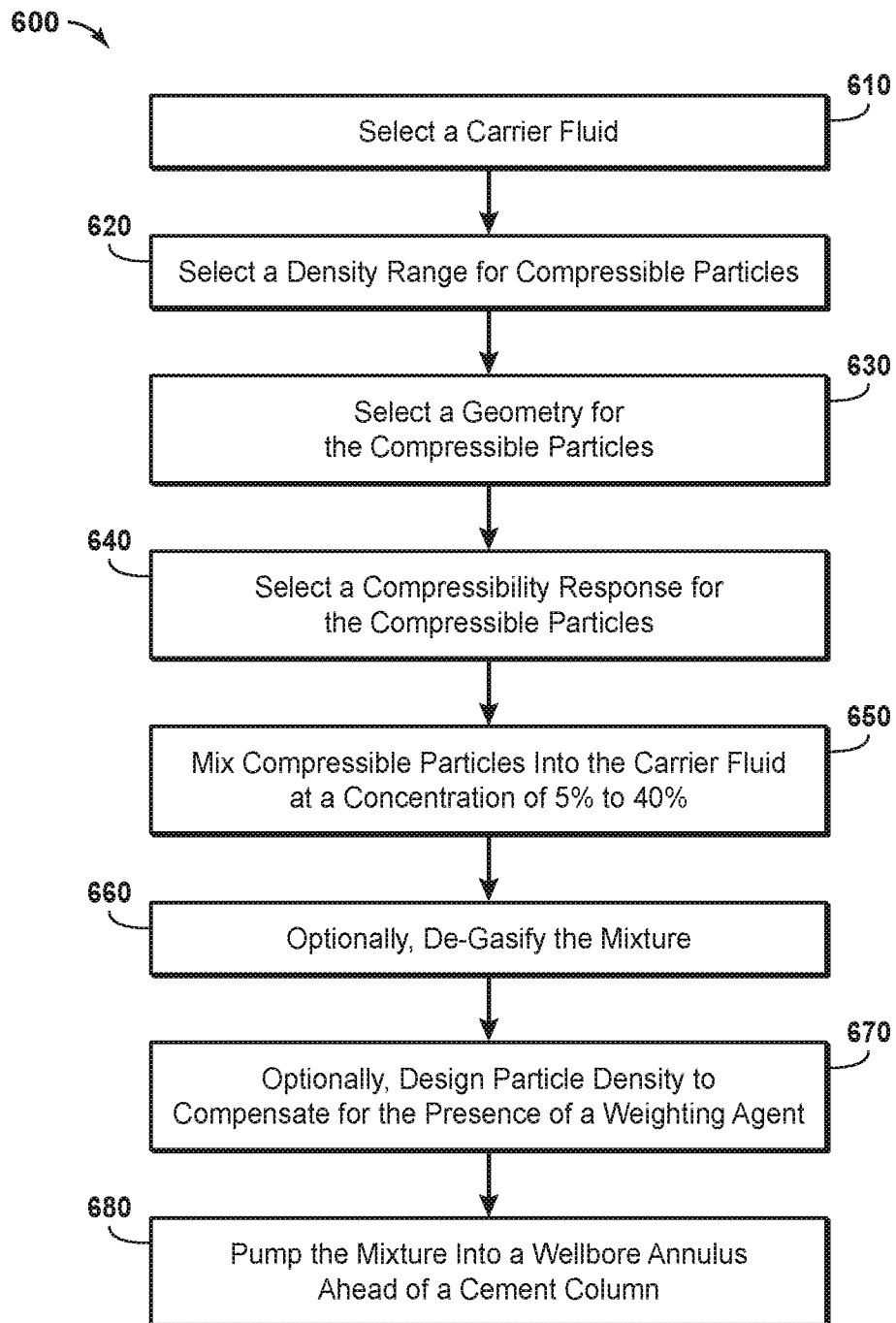

FIG. 6

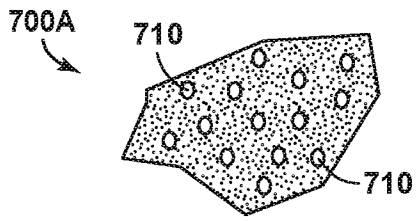

FIG. 7A

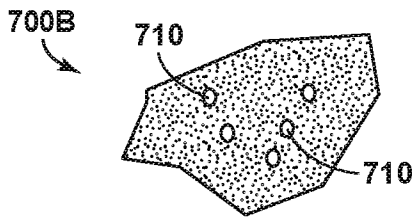

FIG. 7B

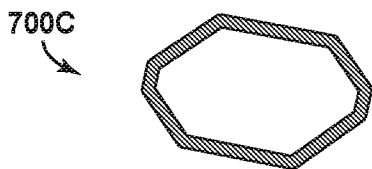

FIG. 7C

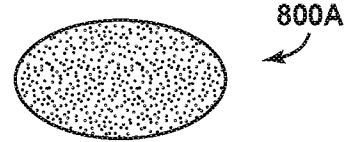

FIG. 8A



FIG. 8B

12/14

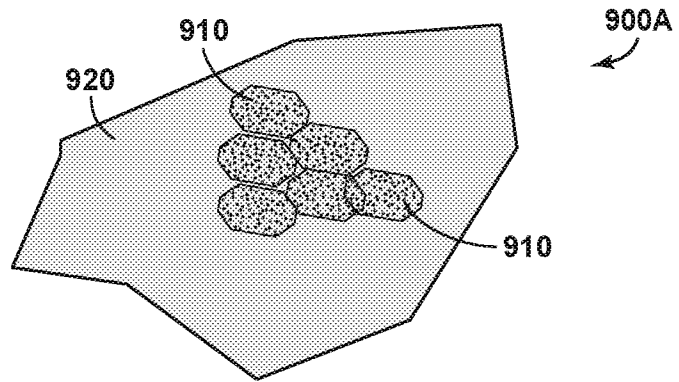

FIG. 9A

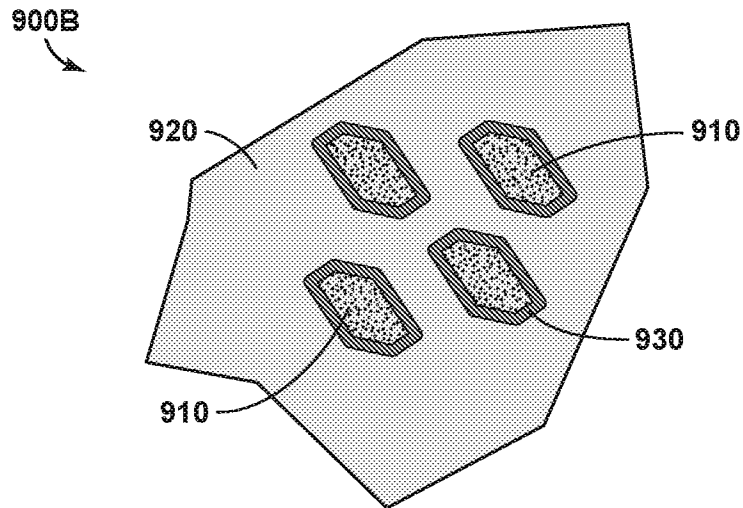

FIG. 9B

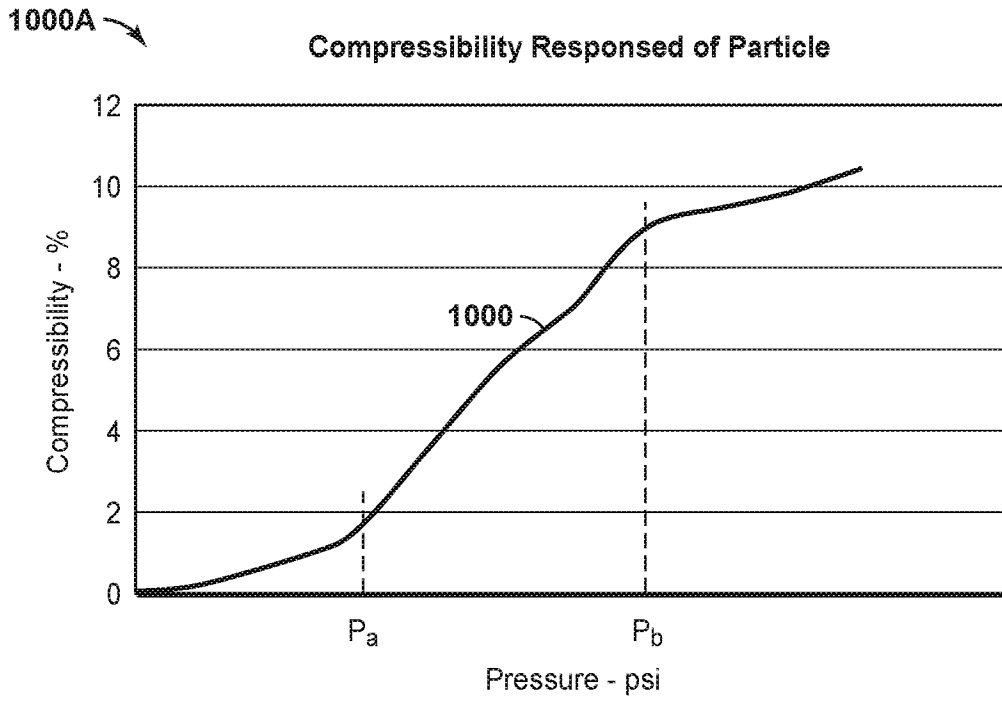

FIG. 10A

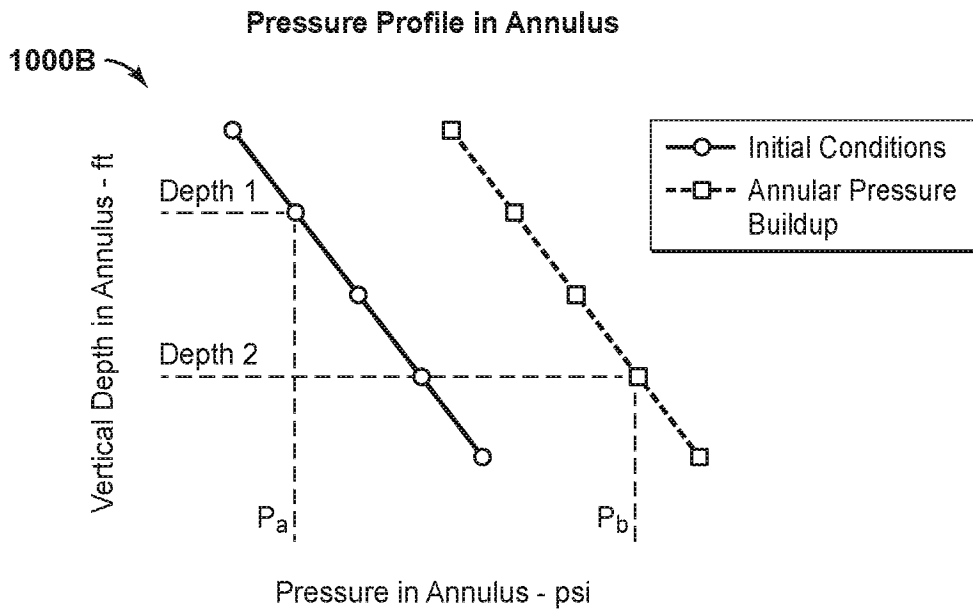

FIG. 10B

14/14

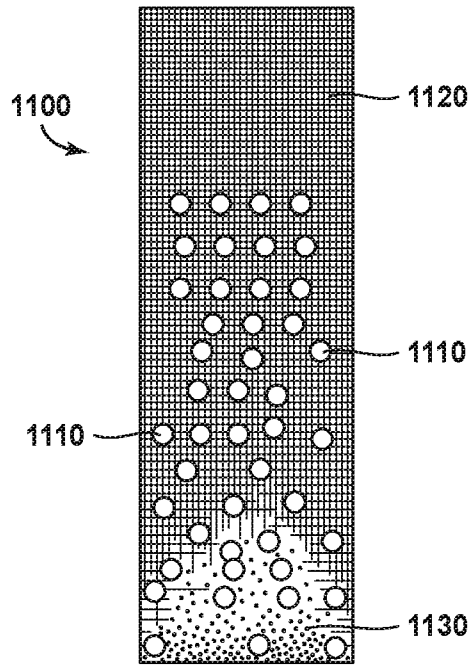

FIG. 11A

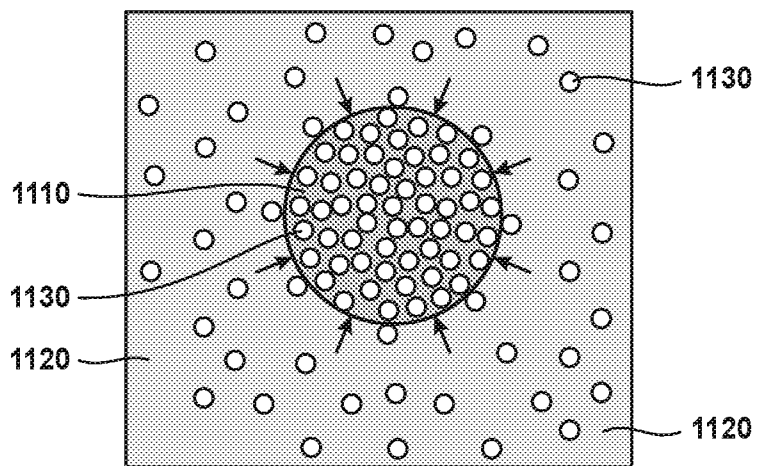

FIG. 11B

INTERNATIONAL SEARCH REPORT

International application No PCT/US2019/061031
--

A. CLASSIFICATION OF SUBJECT MATTER
 INV. E21B17/00 E21B41/00
 ADD.
 According to International Patent Classification (IPC) or to both national classification and IPC

B. FIELDS SEARCHED
 Minimum documentation searched (classification system followed by classification symbols)
E21B C09K
 Documentation searched other than minimum documentation to the extent that such documents are included in the fields searched

Electronic data base consulted during the international search (name of data base and, where practicable, search terms used)
EPO-Internal, WPI Data

C. DOCUMENTS CONSIDERED TO BE RELEVANT

Category*	Citation of document, with indication, where appropriate, of the relevant passages	Relevant to claim No.
A	US 2014/101918 A1 (WOICESHYN GLENN EDWARD [CA] ET AL) 17 April 2014 (2014-04-17) paragraphs [0003], [0023], [0027], [0028], [0033], [0042] - [0048]; figure 4	1-13
A	----- DONG GUANGJIAN ET AL: "A review of the evaluation methods and control technologies for trapped annular pressure in deepwater oil and gas wells", JOURNAL OF NATURAL GAS SCIENCE AND ENGINEERING, ELSEVIER, AMSTERDAM, NL, vol. 37, 19 November 2016 (2016-11-19), pages 85-105, XP029880976, ISSN: 1875-5100, DOI: 10.1016/J.JNGSE.2016.11.042 figures 11, 17, 18, 20, 25, 26 ----- -/--	1-21

Further documents are listed in the continuation of Box C. See patent family annex.

* Special categories of cited documents :

"A" document defining the general state of the art which is not considered to be of particular relevance	"T" later document published after the international filing date or priority date and not in conflict with the application but cited to understand the principle or theory underlying the invention
"E" earlier application or patent but published on or after the international filing date	"X" document of particular relevance; the claimed invention cannot be considered novel or cannot be considered to involve an inventive step when the document is taken alone
"L" document which may throw doubts on priority claim(s) or which is cited to establish the publication date of another citation or other special reason (as specified)	"Y" document of particular relevance; the claimed invention cannot be considered to involve an inventive step when the document is combined with one or more other such documents, such combination being obvious to a person skilled in the art
"O" document referring to an oral disclosure, use, exhibition or other means	"&" document member of the same patent family
"P" document published prior to the international filing date but later than the priority date claimed	

Date of the actual completion of the international search 20 February 2020	Date of mailing of the international search report 20/03/2020
--	---

Name and mailing address of the ISA/ European Patent Office, P.B. 5818 Patentlaan 2 NL - 2280 HV Rijswijk Tel. (+31-70) 340-2040, Fax: (+31-70) 340-3016	Authorized officer Jucker, Chava
--	--

INTERNATIONAL SEARCH REPORT

International application No
PCT/US2019/061031

C(Continuation). DOCUMENTS CONSIDERED TO BE RELEVANT		
Category*	Citation of document, with indication, where appropriate, of the relevant passages	Relevant to claim No.
A	NO 327 689 B1 (STATOILHYDRO ASA [NO]) 14 September 2009 (2009-09-14) figures 3-7 -----	1-21
A	US 2015/184495 A1 (ZHOU CHANGJUN [US] ET AL) 2 July 2015 (2015-07-02) paragraphs [0003], [0004], [0019], [0020]; figures 1A-2B -----	1-21
A	US 2010/113310 A1 (SHEPHERD JAMES E [US] ET AL) 6 May 2010 (2010-05-06) paragraphs [0009] - [0011], [0039] - [0047]; figure 1 -----	1-21

INTERNATIONAL SEARCH REPORT

Information on patent family members

International application No PCT/US2019/061031

Patent document cited in search report	Publication date	Patent family member(s)	Publication date	
US 2014101918	A1	17-04-2014	CA 2801954 A1	15-12-2011
			EP 2580425 A1	17-04-2013
			RU 2013101004 A	20-07-2014
			SG 186285 A1	30-01-2013
			US 2013112400 A1	09-05-2013
			US 2014101918 A1	17-04-2014
			WO 2011153636 A1	15-12-2011

NO 327689	B1	14-09-2009	NONE	

US 2015184495	A1	02-07-2015	CA 2926145 A1	02-07-2015
			EP 3087154 A1	02-11-2016
			US 2015184495 A1	02-07-2015
			WO 2015099878 A1	02-07-2015

US 2010113310	A1	06-05-2010	BR PI0919646 A2	08-12-2015
			EA 201100692 A1	28-02-2012
			EG 26279 A	11-06-2013
			EP 2350434 A2	03-08-2011
			US 2010113310 A1	06-05-2010
			WO 2010051165 A2	06-05-2010
