



US007208349B2

(12) **United States Patent**
Lee et al.

(10) **Patent No.:** **US 7,208,349 B2**
(45) **Date of Patent:** **Apr. 24, 2007**

(54) **PACKAGE SUBSTRATE MANUFACTURED USING ELECTROLYTIC LEADLESS PLATING PROCESS, AND METHOD FOR MANUFACTURING THE SAME**

(75) Inventors: **Jong-Jin Lee**, Daejeon (KR);
Young-Hwan Shin, Daejeon (KR)

(73) Assignee: **Samsung Electro-Mechanics Co., Ltd.**,
Suwon (KR)

(*) Notice: Subject to any disclaimer, the term of this patent is extended or adjusted under 35 U.S.C. 154(b) by 131 days.

(21) Appl. No.: **11/003,737**

(22) Filed: **Dec. 6, 2004**

(65) **Prior Publication Data**

US 2005/0095862 A1 May 5, 2005

Related U.S. Application Data

(62) Division of application No. 10/609,499, filed on Jul. 1, 2003.

(30) **Foreign Application Priority Data**

Feb. 24, 2003 (KR) 2003-11513

(51) **Int. Cl.**
H01L 21/44 (2006.01)

(52) **U.S. Cl.** **438/125; 257/700**

(58) **Field of Classification Search** **438/120-125, 438/411; 257/734-738, 700-701, 774, E23.009, 257/E23.029, E23.062; 361/111-115**
See application file for complete search history.

(56) **References Cited**

U.S. PATENT DOCUMENTS

6,208,525 B1 3/2001 Imasu et al.

6,407,341 B1	6/2002	Anstrom et al.	174/255
6,649,506 B2	11/2003	Hsu	
6,762,921 B1	7/2004	Asai et al.	
2003/0011070 A1	1/2003	Iijima et al.	
2004/0048414 A1	3/2004	Heinz et al.	
2004/0099939 A1	5/2004	Alcoe et al.	
2004/0154166 A1	8/2004	Lee et al.	
2004/0201095 A1 *	10/2004	Palmer et al.	257/700
2005/0067713 A1 *	3/2005	Mutta et al.	257/774
2005/0218503 A1 *	10/2005	Abe et al.	257/700
2006/0023439 A1 *	2/2006	Fralely et al.	361/780

* cited by examiner

Primary Examiner—Nathan W. Ha

(74) *Attorney, Agent, or Firm*—Morgan, Lewis & Bockius, LLP

(57) **ABSTRACT**

A method of manufacturing a package substrate includes forming a first copper plated layer on a base substrate having through holes and inner surfaces of the through hole, coating a first resist over the first copper plated layer, partially removing the first resist, forming a second copper plated layer on the first copper plated layer, stripping the first resist, coating a second resist over the resultant structure, and removing the second resist from regions where wire bonding pads and solder ball pads are to be formed, removing exposed portions of the first copper plated layer, forming the wire bonding pads and the solder ball pads, removing the second resist, removing exposed portions of the first copper plated layer, and coating a solder resist over all surfaces of the resultant structure, and removing portions of the solder resist respectively covering the wire bonding pads and the solder ball pads.

6 Claims, 18 Drawing Sheets

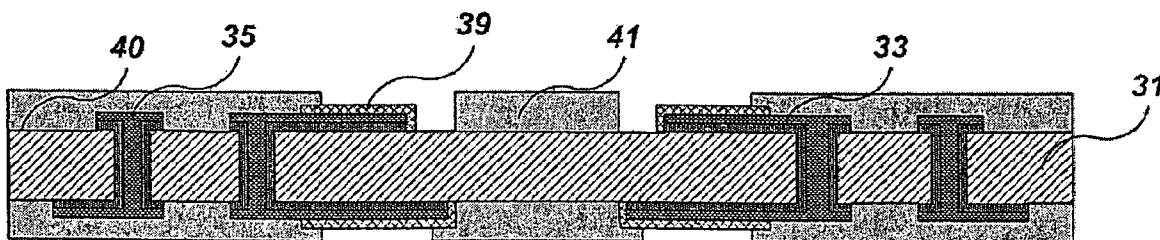

Fig. 1

PRIOR ART

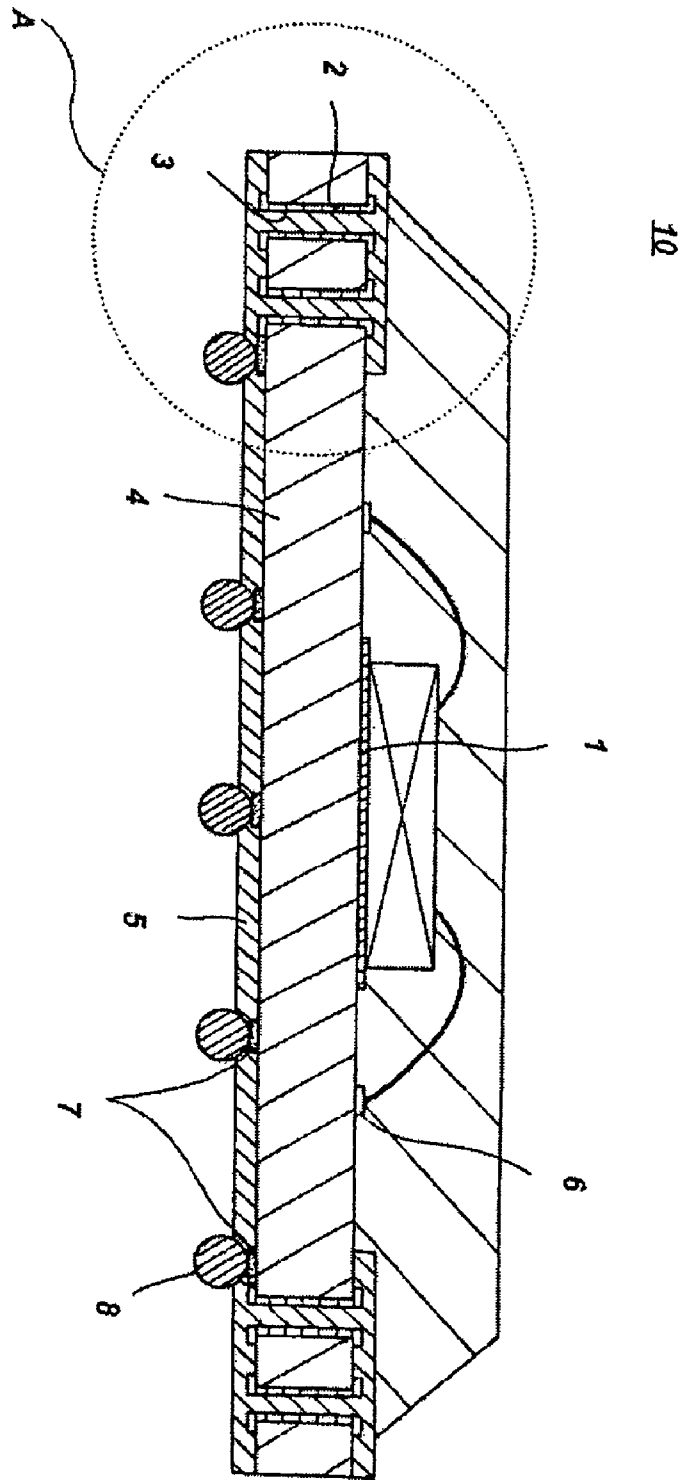

Fig. 2

PRIOR ART

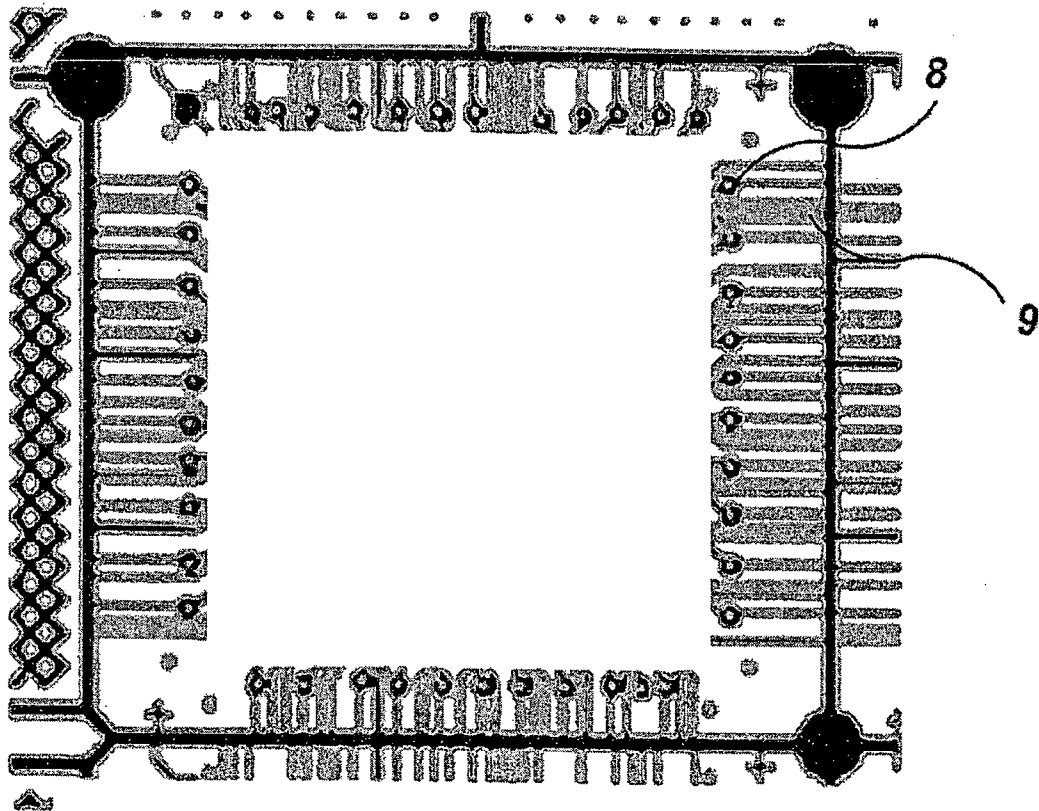

Fig. 3a

PRIOR ART

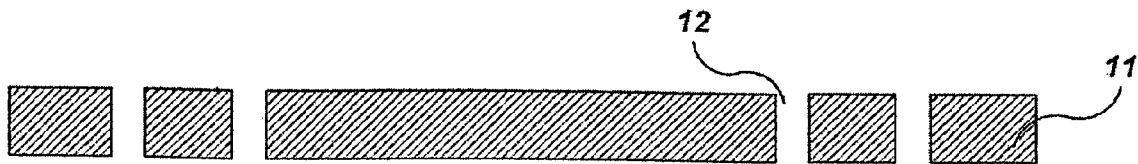

Fig. 3b

PRIOR ART

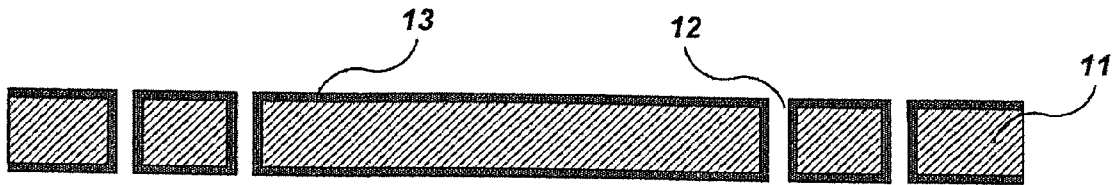

Fig. 3c

PRIOR ART

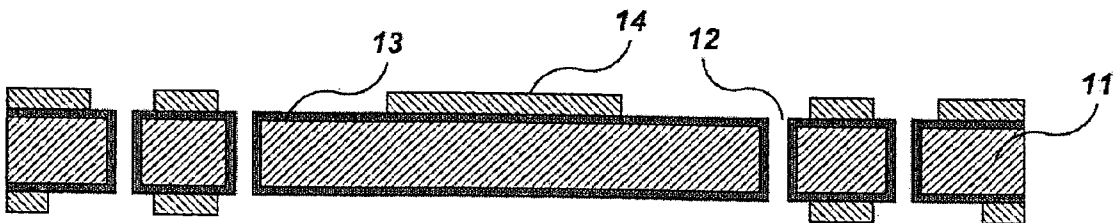

Fig. 3c

PRIOR ART

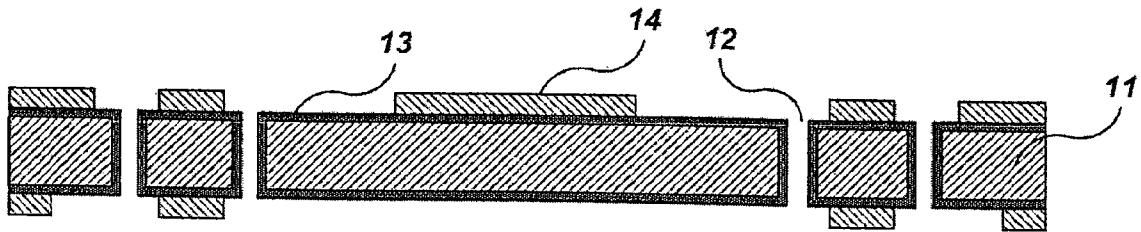

Fig. 3d

PRIOR ART

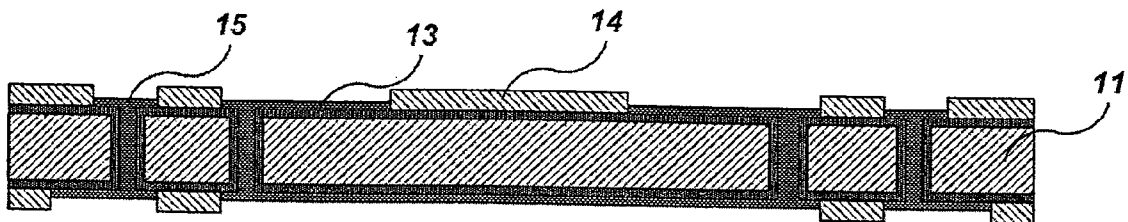

Fig. 3e

PRIOR ART

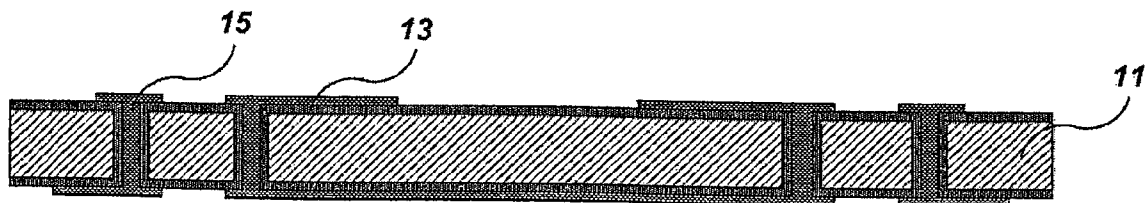

Fig. 3f

PRIOR ART

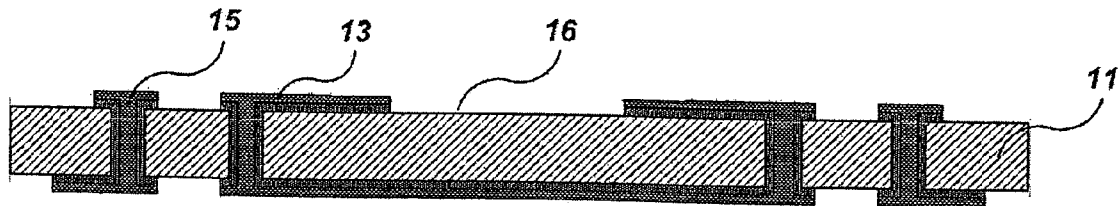

Fig. 3g

PRIOR ART

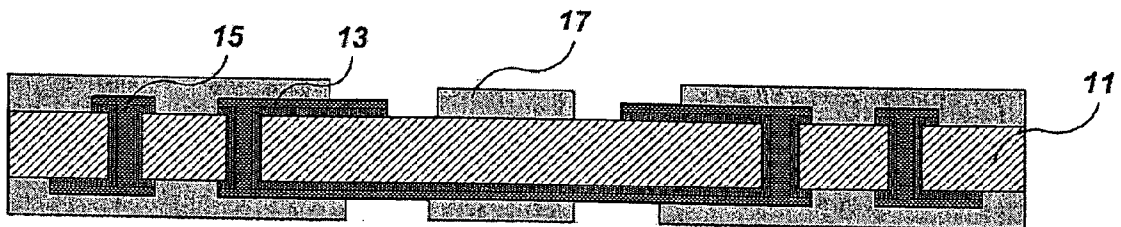

Fig. 3h

PRIOR ART

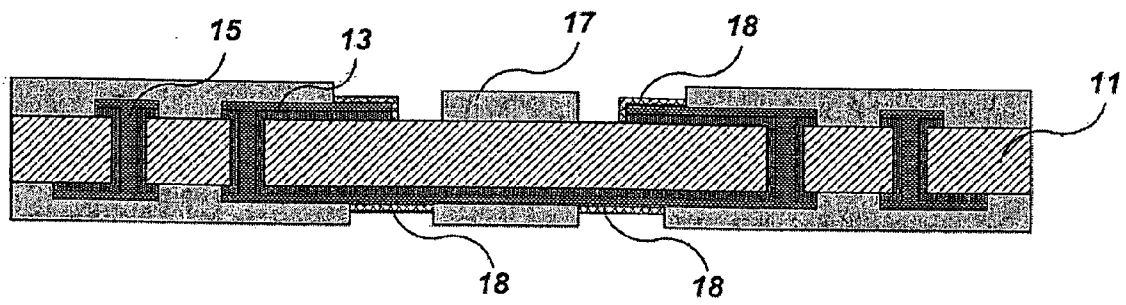

Fig. 3i

PRIOR ART

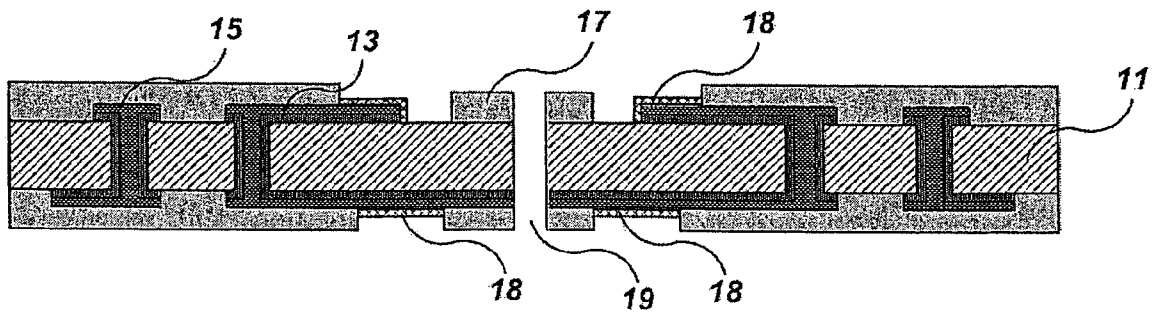

Fig. 4

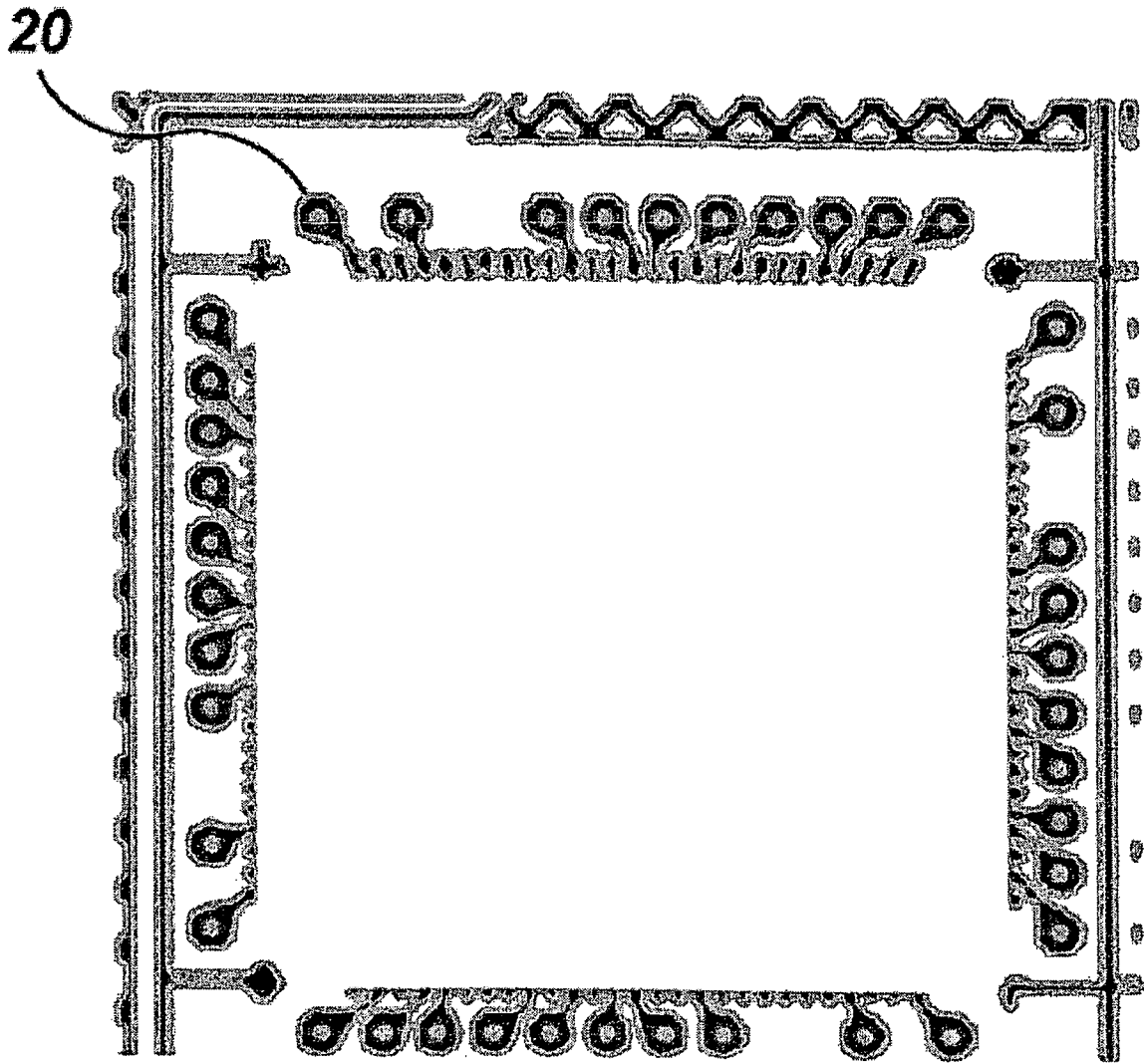

Fig. 5

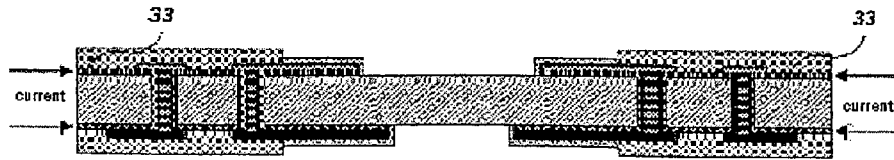

Fig. 6a

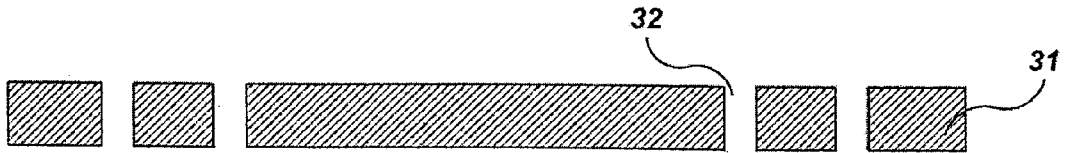

Fig. 6b

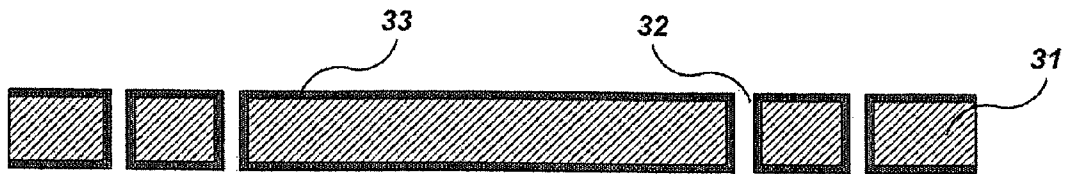

Fig. 6c

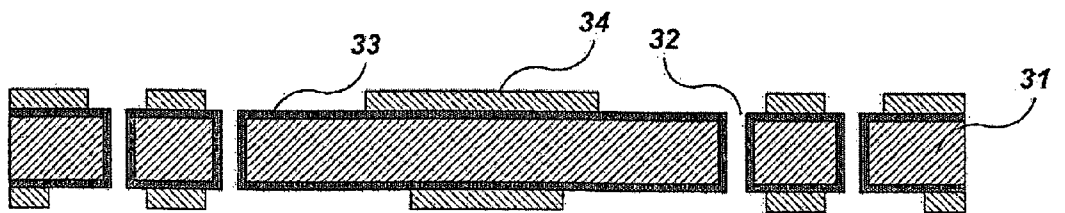

Fig. 6d

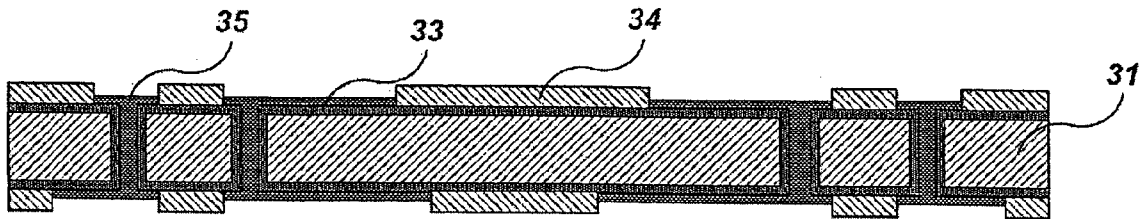

Fig. 6e

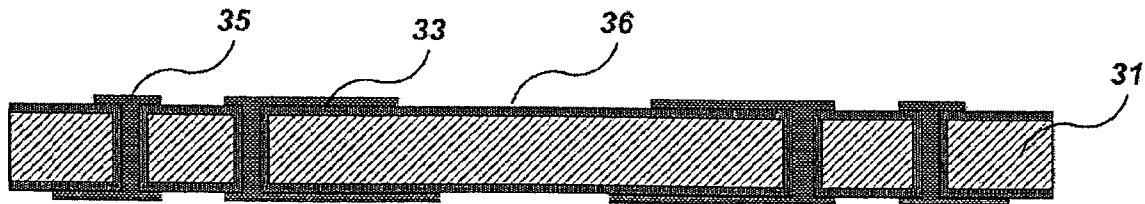

Fig. 6f

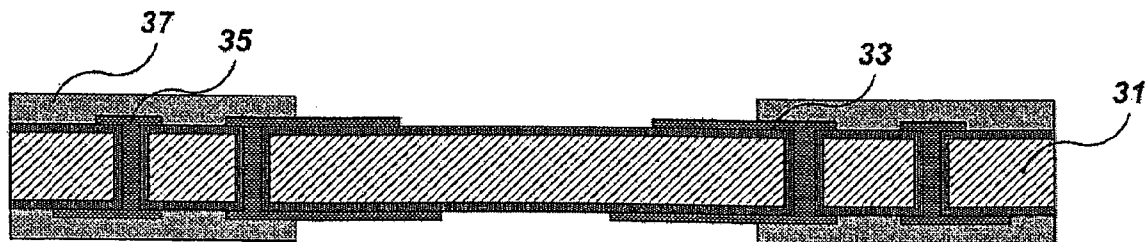

Fig. 6g

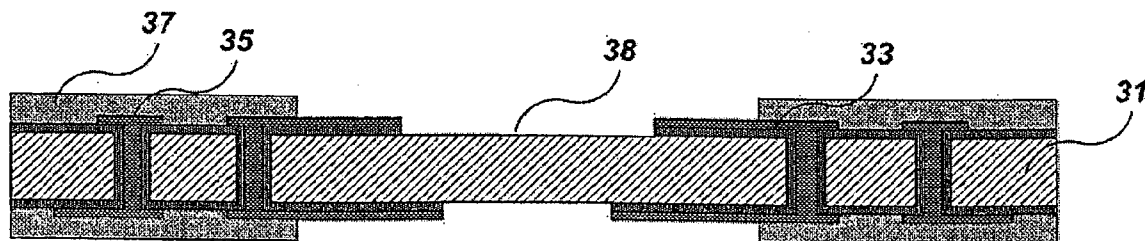

Fig. 6h

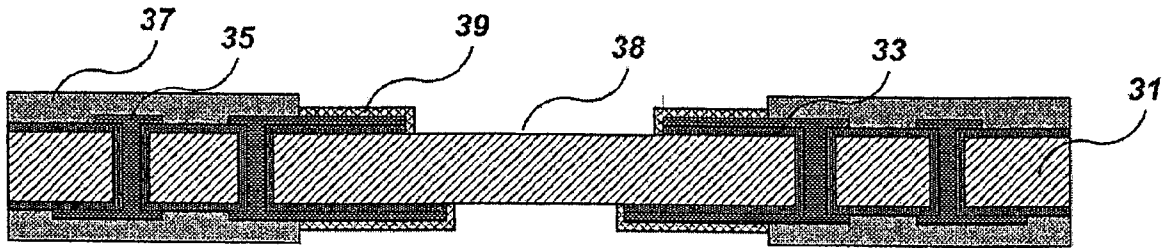

Fig. 6i

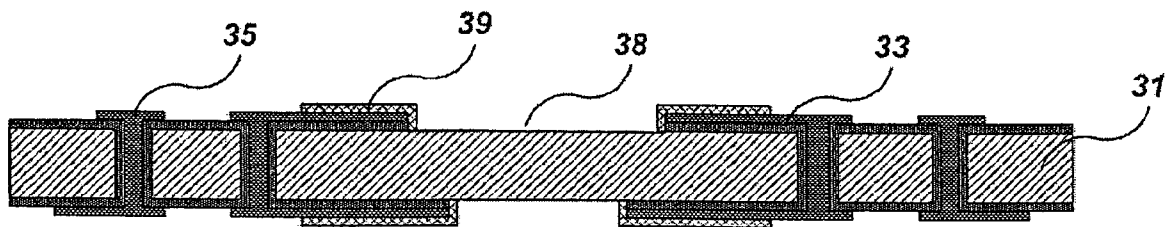

Fig. 6j

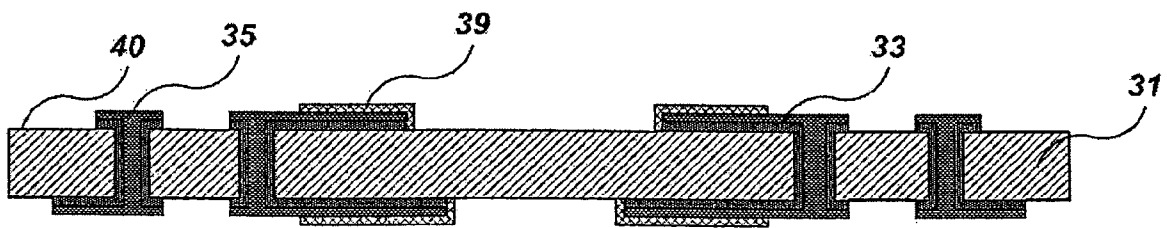

Fig. 6k

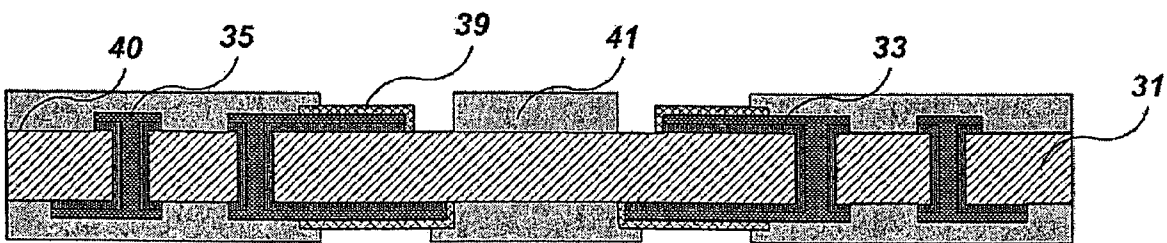

Fig. 7a

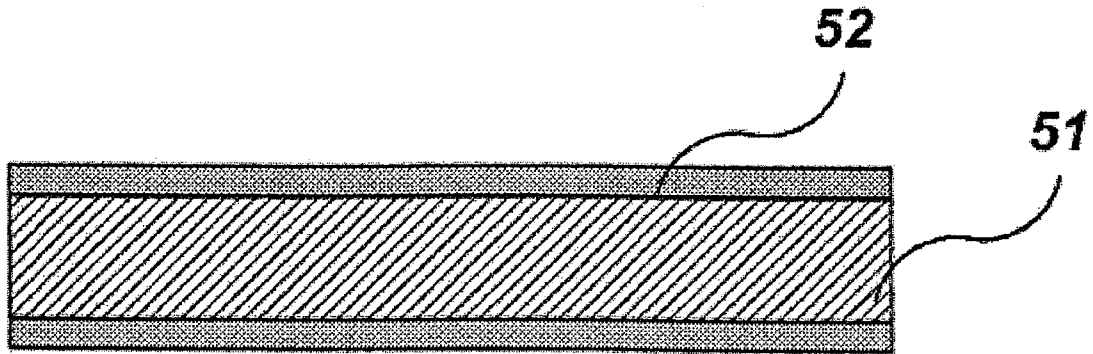

Fig. 7b

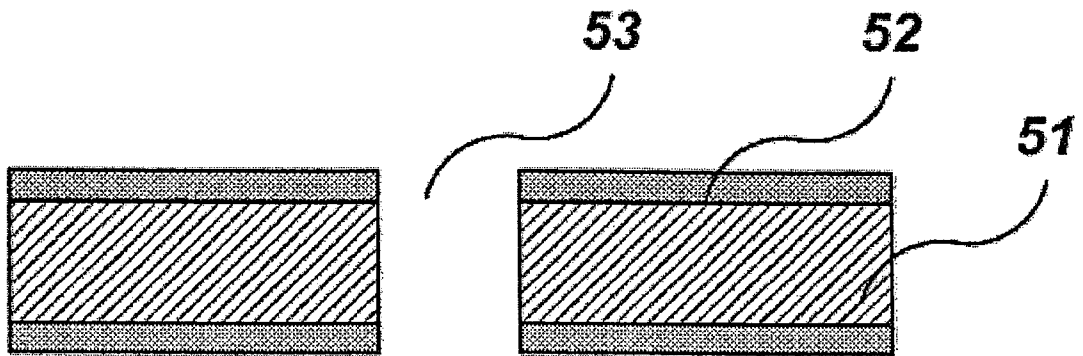

Fig. 7c

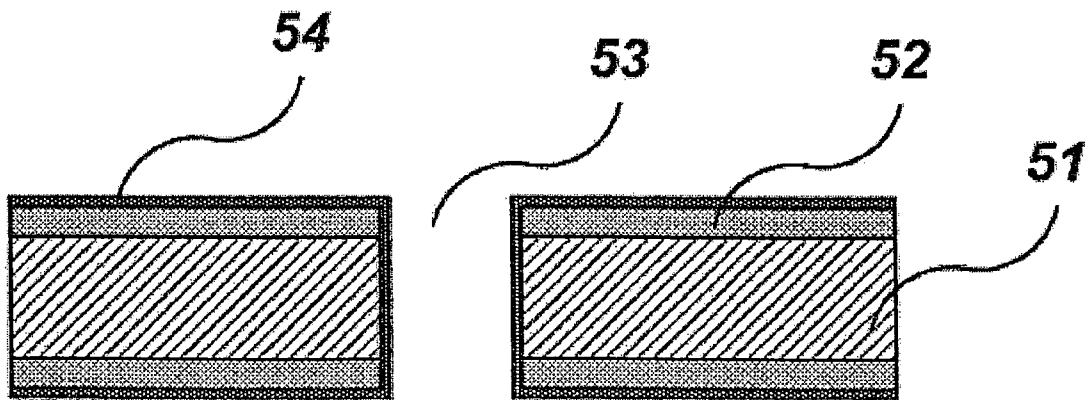

Fig. 7d

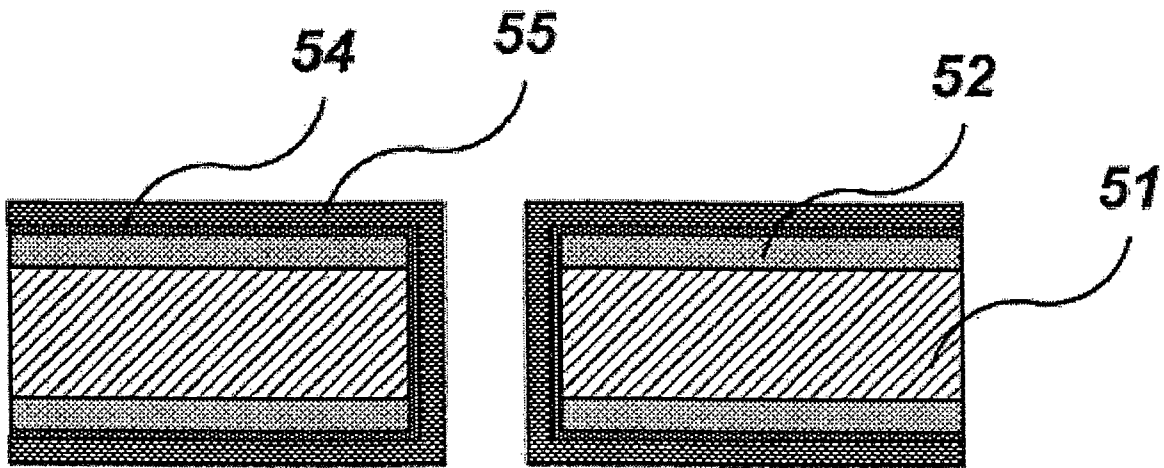

Fig. 7e

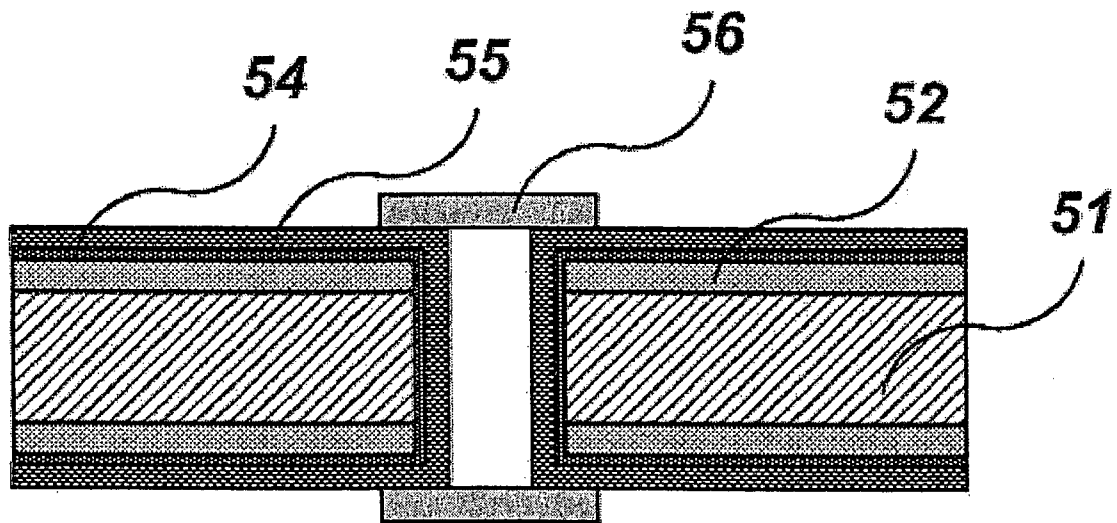

Fig. 7f

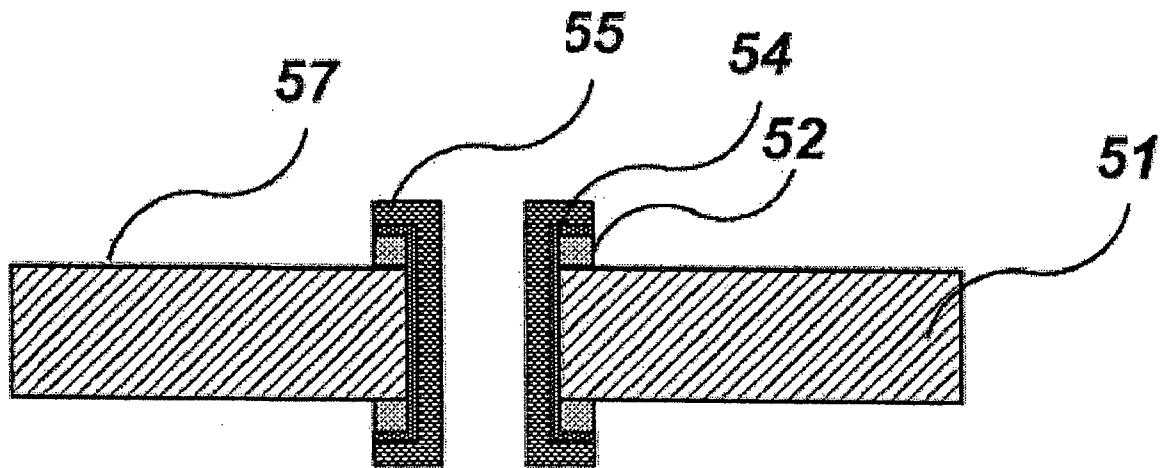

Fig. 8a

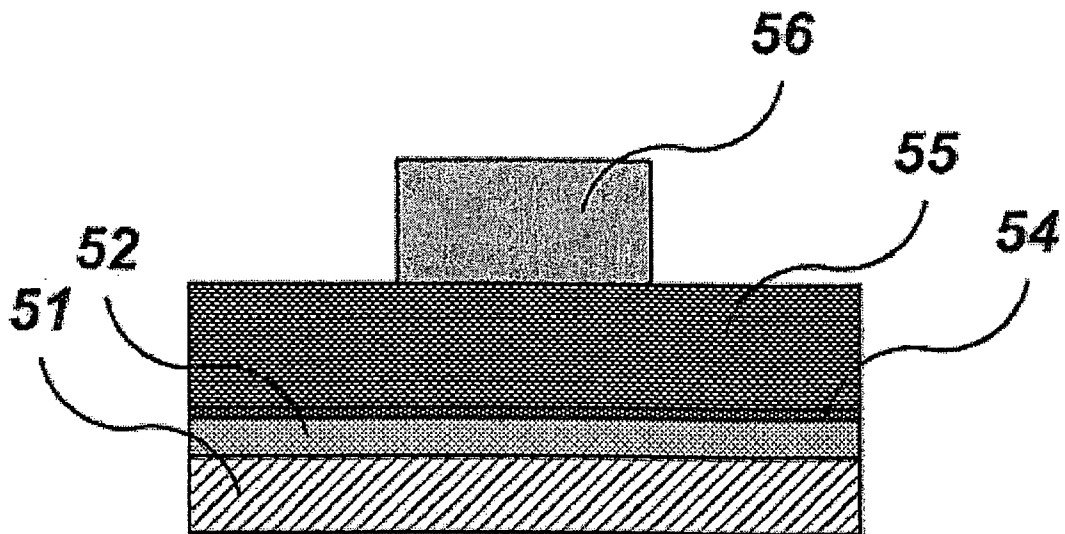

Fig. 8b

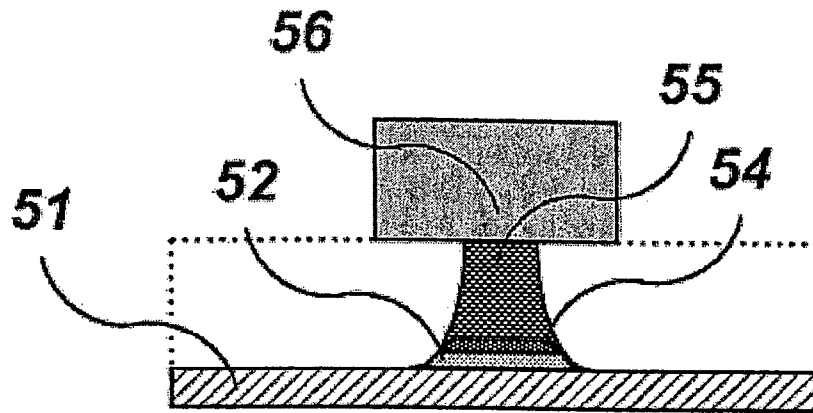

Fig. 9a

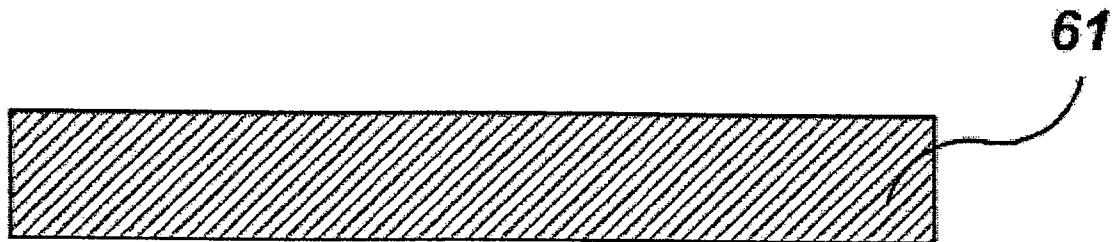

Fig. 9b

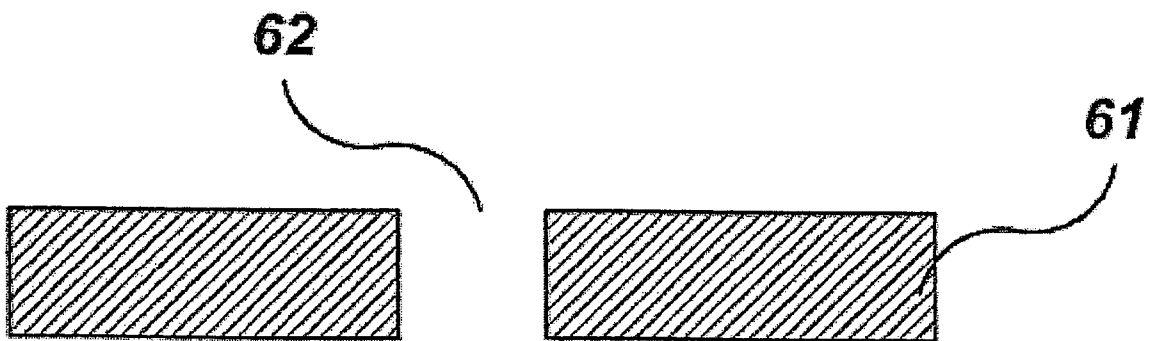

Fig. 9c

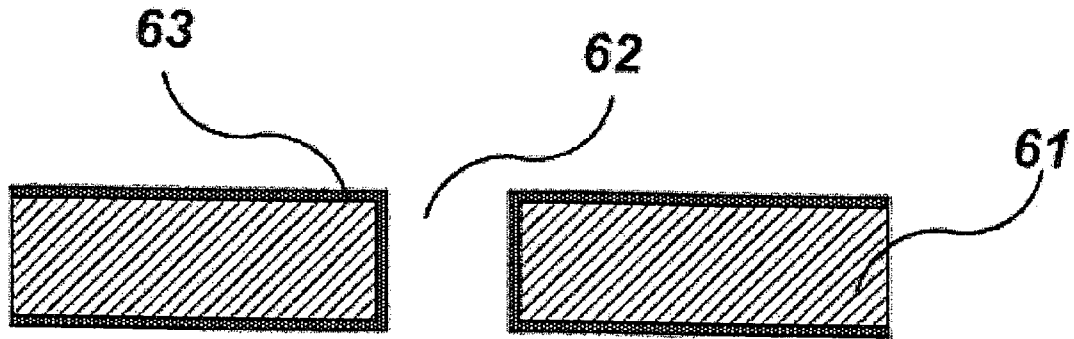

Fig. 9d

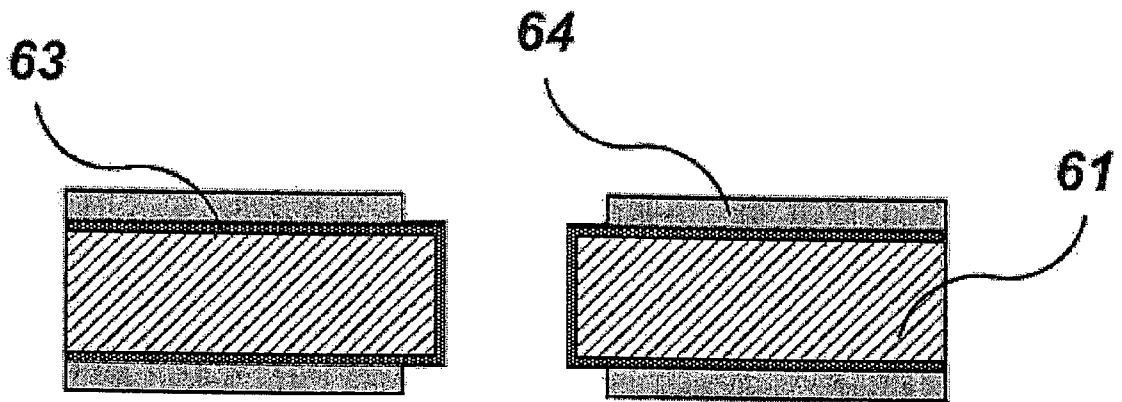

Fig. 9e

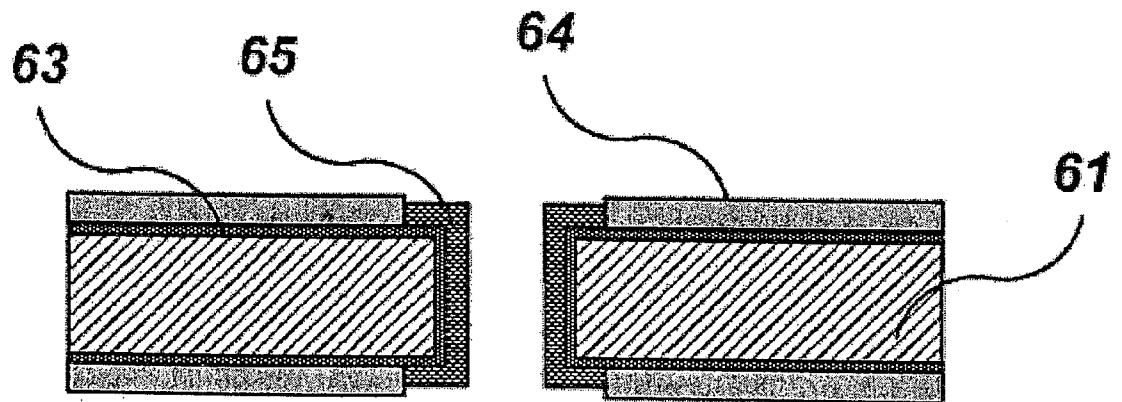

Fig. 9f

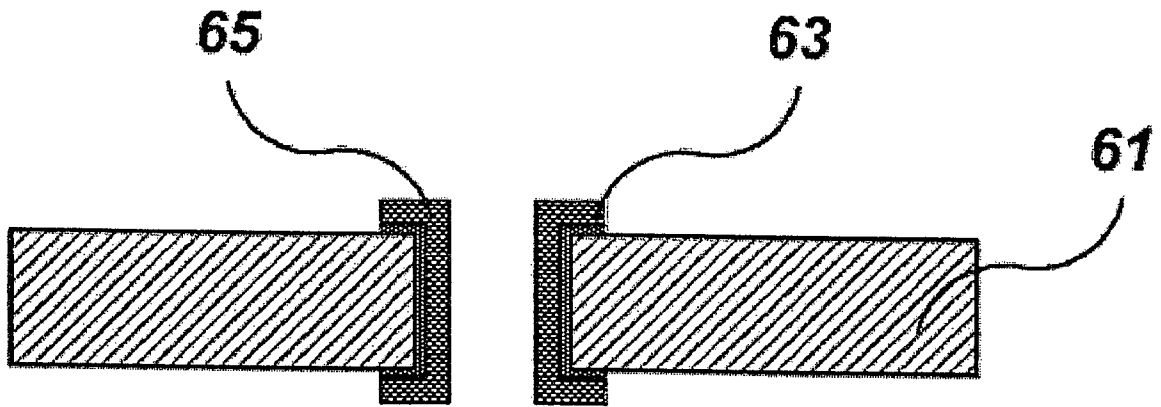

Fig. 10a

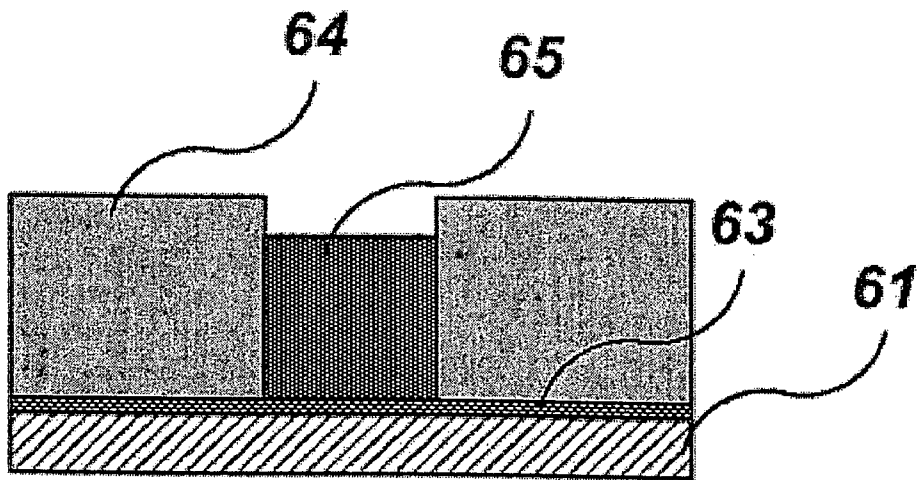

Fig. 10b

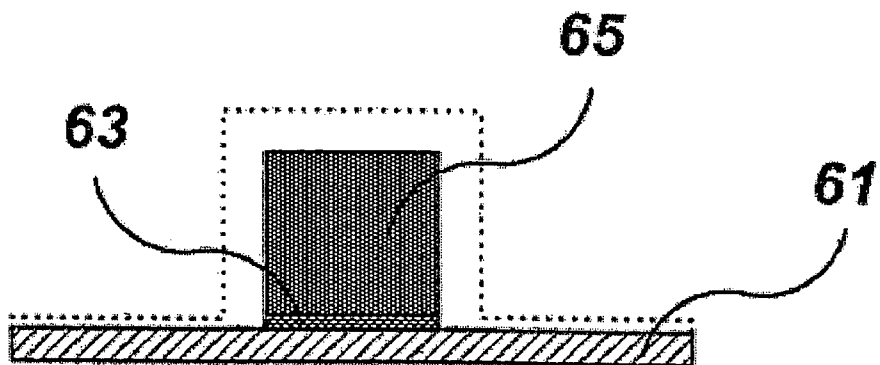

Fig. 11a

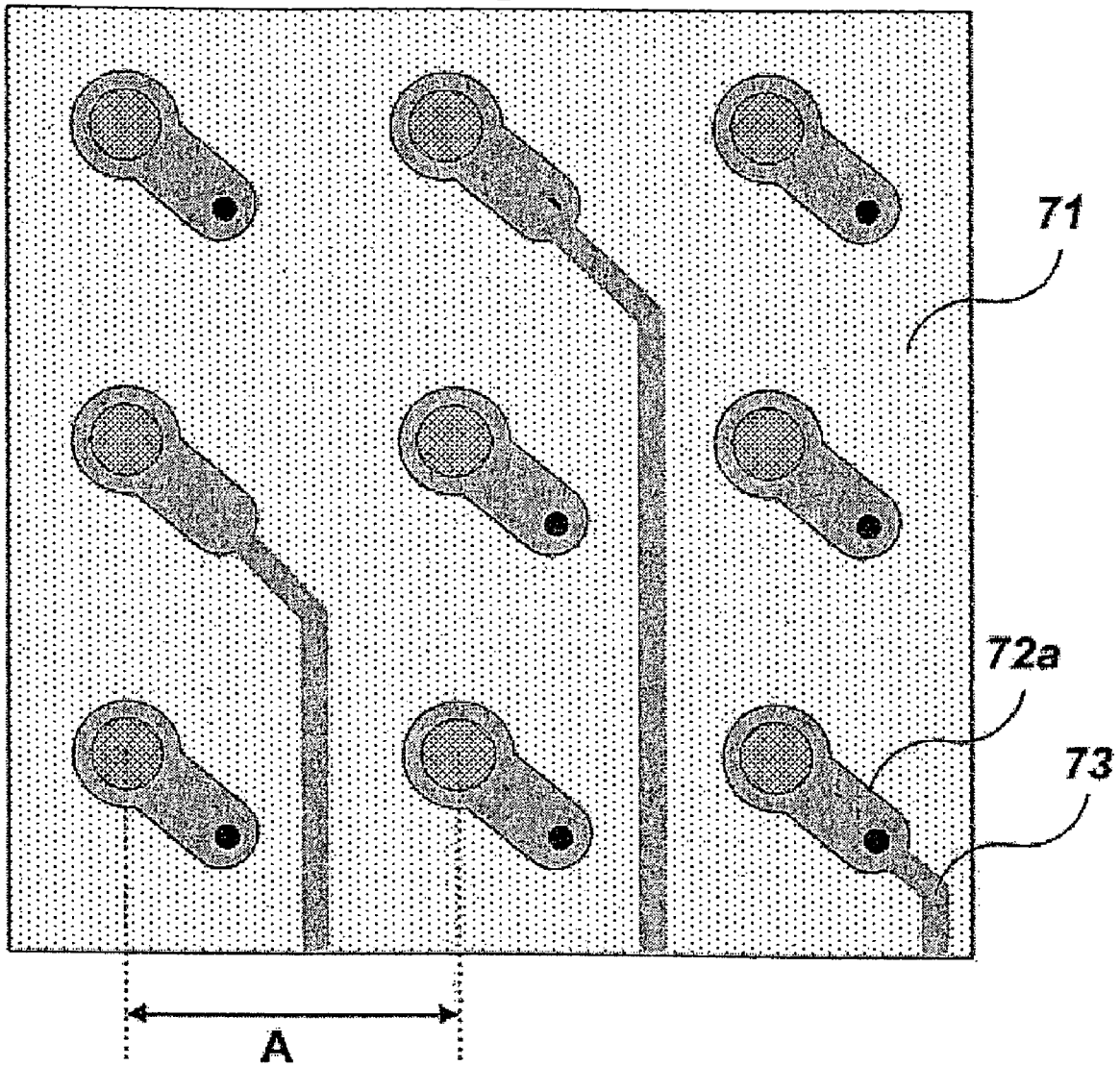
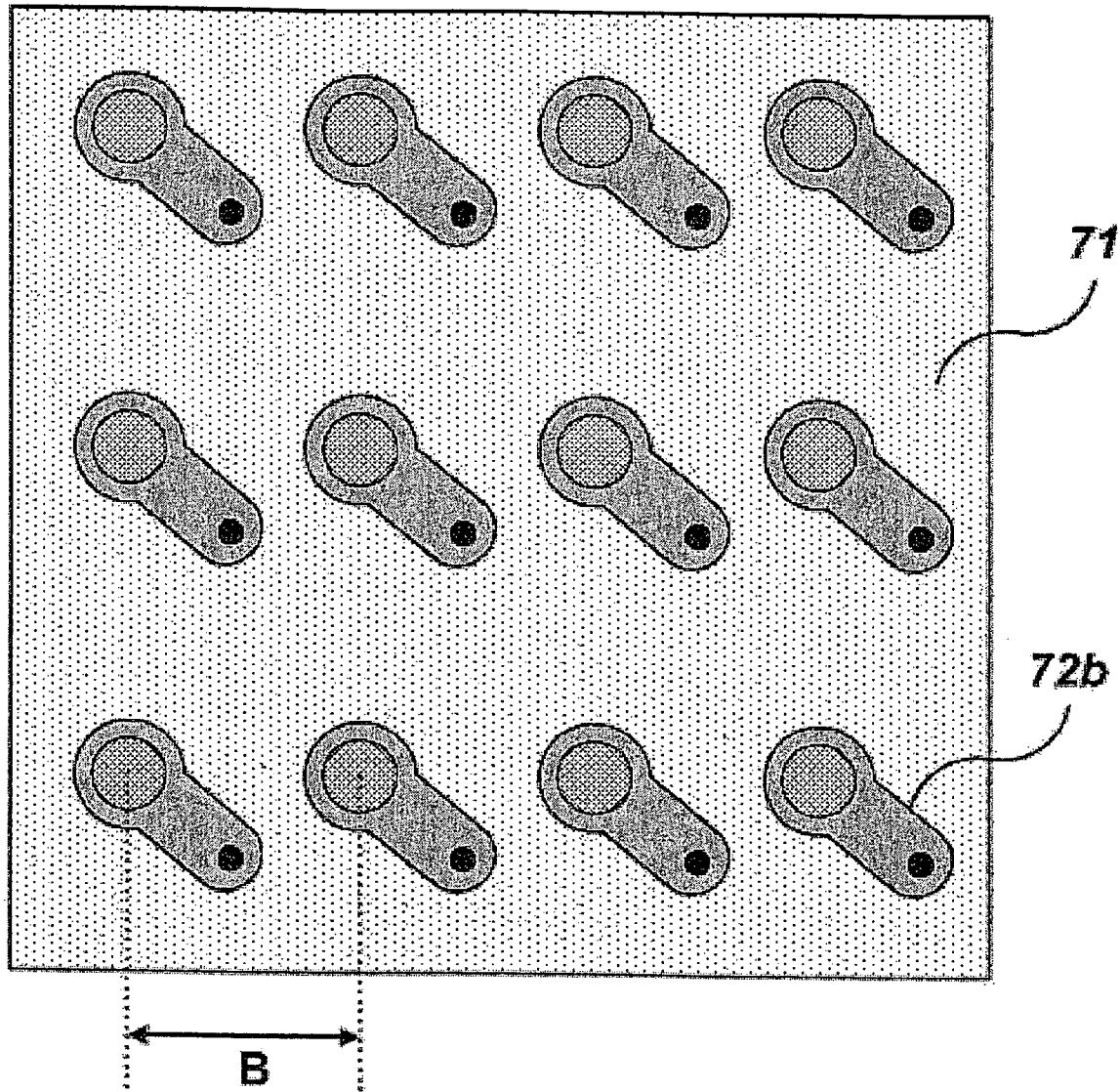

Fig. 11b



**PACKAGE SUBSTRATE MANUFACTURED
USING ELECTROLYTIC LEADLESS
PLATING PROCESS, AND METHOD FOR
MANUFACTURING THE SAME**

This is a divisional application of copending Application Ser. No. 10/609,499 filed on July 1, 2003.

BACKGROUND OF THE INVENTION

1. Field of the Invention

The present invention relates to a package substrate manufactured using an electrolytic leadless plating process, and a method for manufacturing the same. More particularly, the present invention relates to a package substrate of, for example, a ball grid array (BGA) type or a chip scale package (CSP) type, manufactured by electrolytically plating Au in a semi-additive manner without using any plating lead line on wire bonding pads to be connected with a semiconductor chip mounted on a base substrate, and solder ball pads, and a method for manufacturing the same.

2. Description of the Related Art

In spite of the recent tendency of integrated circuits to have a light, thin, simple and miniature structure, integrated circuit packages rather tend to have an increased number of leads extending outwardly therefrom. One method capable of solving problems caused by installation of a number of leads on a carrier for a miniature package is to use a carrier having a pin grid array (PGA). Although such a PGA carrier can have a number of leads while having a miniature size, it has a drawback in that its pins or leads may be easily broken due to their low strength, or involves a limitation of high-density integration.

In order to solve such drawbacks involved with PGA, use of BGA package substrates has recently been generalized. The reason why such a BGA package substrate has been generally used is that it is possible to easily achieve a high-density integration of the substrate in accordance with use of solder balls finer than pins. Such a BGA package substrate is mainly used for a package substrate adapted to mount a semiconductor chip thereon.

A conventional example of such a BGA package will be described in brief hereinafter. Referring to FIG. 1, a conventional BGA package is shown which has a structure formed with solder balls **8**, in place of conventional pins. In order to fabricate this structure, a plurality of copper clad laminates (CCLs) **4** are first prepared. An inner-layer circuit is formed at each of the CCLs **4** in accordance with a well-known photolithography process. The CCLs **4** are then laminated in accordance with a pressing process. Thereafter, via holes **2** are formed at the laminated CCL structure in order to electrically connect the inner-layer circuits of respective CCLs. The via holes **2** are plated with a copper film **3** so that they are electrically connected. An outer-layer circuit **6** is subsequently formed at the outermost CCL **4** of the laminated CCL structure in accordance with a photolithography process. The outer-layer circuit **6** has bond fingers **1** to be connected with a semiconductor chip mounted on the laminated CCL structure. Thereafter, solder ball pads **7**, a solder mask **5**, and solder balls **8** are sequentially formed at a surface of the laminated CCL structure opposite to the outer-layer circuit **6**.

Meanwhile, Au-plating lead lines are formed in order to perform a plating process adapted to obtain improved electrical connections of the pads **7** with both the bond fingers **1** connected to the semiconductor chip and the solder balls **8**. Each Au-plating lead line is connected to an associated

one of the pads **7** connected to respective solder balls **8**. Although not shown, the Au-plating lead lines are also connected to the bond fingers **1** via the pads **7** and via holes **2**, respectively. FIG. 2 is a plan view illustrating the package substrate plated using conventional plating lead lines. As shown in FIG. 2, plating lead lines **9** are connected to respective solder ball pads **7** at which respective solder balls **8** are formed. The area where the plating lead lines **9** are formed corresponds to the portion A of FIG. 1. Substantially, there is a limitation of high-density integration in designing a circuit, due to such plating lead lines.

On the other hand, an integrated circuit (IC) chip is mounted on the CCL **4** formed with the outer-layer circuit **6**, while being connected with the outer-layer circuit **6** by conductive lines. An encapsulant is coated over the CCL **4** to protect the CCL **4** from the surroundings. Thus, the BGA package substrate **10** is connected with a main circuit board by the solder balls **8** formed at the pads **7** of the pad-carried CCL **4**, as compared to a PGA substrate which is connected to a main circuit board by pins. For this reason, it is possible to easily miniaturize BGAs, as compared to PGAs. Accordingly, the BGA substrate **10** can achieve high-density integration.

However, the above mentioned conventional BGA package substrate **10** involves a problem in that it is difficult to achieve high-density integration of the Au-plating lead lines adapted to carry out an Au plating process for the bond fingers **1** and pads **7** because the pitch of the solder balls **8** in the BGA package substrate, that is, the space between adjacent solder balls, is rendered to be very small due to high-density integration of circuits and miniaturization of devices using such circuits, and because of high-density integration of circuits arranged around the bond fingers **1** of the outer-layer circuit mounted with the semiconductor chip thereon.

Now, a conventional method for manufacturing a package substrate plated with Au using plating lead lines will be described with reference to FIGS. 3*a* to 3*i*.

First, a plurality of through holes, that is, via holes, **12**, are formed at a base substrate **11** (FIG. 3*a*). A copper film **13** is plated in accordance with an electroless plating process to cover the entire surface of the base substrate **11** and the inner surface of each through hole **12** (FIG. 3*b*).

In order to manufacture a package substrate provided with desired circuits, a resist **14** for a copper plating process is then coated over the plated upper and lower surfaces of the base substrate **11**. The resist **14** is subsequently subjected to exposure and development processes so that it is patterned in such a fashion that it is removed from portions of the copper-plated surfaces of the base substrate **11** respectively corresponding to regions where desired circuit patterns are to be plated (FIG. 3*c*). The via holes **12** are formed by perforating through holes into the base substrate **11** using a mechanical drill. For the resist **14**, a dry film is typically used.

Thereafter, circuit patterns **15** are formed, in accordance with a plating process, on the copper-plated surface portions of the base substrate **11** corresponding to respective regions where the resist **14** is not present (FIG. 3*d*). The remaining resist **14** is then completely removed using a stripping solution (FIG. 3*e*).

Subsequently, portions of the copper film **13** exposed on the base substrate in accordance the removal of the resist **14** are removed using an etchant (FIG. 3*f*). In FIG. 3*f*, the reference numeral **16** denotes regions where the copper film **13** is etched by the etchant.

A solder resist **17** is then coated over the entire surface of the resultant structure, and subjected to exposure and development processes so that it is removed from regions where Au is to be plated in accordance with an electrolytic plating process, that is, wire bonding pads and solder ball pads are to be formed (FIG. 3g).

An Au film **18** is plated on wire bonding pads and solder ball pads included in respective circuits by applying current to the previously formed plating lead lines. The plating of the Au film **18** may be achieved in accordance with an electrolytic Ni—Au plating process. Typically, the thickness of the plated Au film **18** is about 0.5 to 1.0 μm (FIG. 3h).

Generally, an electrolytic Au plating process is mainly used for metal finishing of the surface of a package substrate on which a semiconductor chip is mounted, because it is superior over an electroless Au plating process, in terms of reliability. For such an electrolytic Au plating process, however, it is necessary to design the package substrate to be provided with plating lead lines. For this reason, there is a reduction in line density. Such a reduced line density causes a problem in manufacturing a circuit having a high-density integration.

Thereafter, the plating lead lines are cut using a router or a dicing process (FIG. 3i). In FIG. 3i, the reference numeral **19** denotes a region where the dicing process is carried out. That is, the plating lead lines are cut using the router or dicing process, after completion of the electrolytic Au plating process. However, the plating lead lines are incompletely removed from the package substrate. The residues of the plating lead lines may cause noise during transmission of electrical signals in the circuits provided at the package substrate. As a result, there is a degradation in electrical performance.

Meanwhile, recently, manufacturers of package substrates have made an effort to develop a technique capable of carrying out an electrolytic Au plating process without using any plating lead line. In the above mentioned conventional electrolytic Au plating process, both the wire bonding pads and the solder ball pads are plated with Au to the same thickness (in most cases, 0.5 to 1.5 μm). In the case of the solder ball pads, however, such a thickness is excessive, as compared to an appropriate thickness of 0.03 to 0.25 μm . For this reason, there is a problem associated with the reliability of the bonding of solder balls.

SUMMARY OF THE INVENTION

The present invention has been made in view of the above mentioned problems, and an object of the invention is to provide a package substrate manufactured in a semi-additive manner without using any plating lead line, thereby being capable of achieving an improvement in line density, and a method for manufacturing the package substrate.

Another object of the invention is to provide a package substrate capable of completely removing all plating lead lines used in a normal electrolytic Au plating process, thereby achieving suppression of noise.

In accordance with one aspect, the present invention provides a method for manufacturing a package substrate without using any plating lead line, comprising the steps of: a) plating copper on all surfaces of a base substrate formed with a plurality of through holes and inner surfaces of the through holes, thereby forming a first copper plated layer; b) coating a first resist for a plating process over the first copper plated layer, partially removing the first resist, thereby exposing predetermined portions of the first copper plated layer respectively corresponding to regions where circuit

patterns are to be plated; c) plating copper on the exposed portions of the first copper plated layer, thereby forming a second copper plated layer; d) stripping the first resist remaining on the first copper plated layer; e) coating a second resist for a plating process over all surfaces of a structure obtained after completion of the step (d), and removing the second resist from regions where wire bonding pads and solder ball pads are to be formed; f) removing portions of the first copper plated layer exposed without being covered by the second resist, by use of an etchant; g) forming an Au layer on portions of the second copper plated layer exposed without being covered by the second resist in accordance with an electrolytic Ni—Au plating process, thereby forming the wire bonding pads and the solder ball pads; h) removing the second resist remaining on the structure by use of a stripping solution; i) removing portions of the first copper plated layer exposed in accordance with the removal of the second resist, by use of an etchant; and j) coating a solder resist over all surfaces of a structure obtained after completion of the step (i), and removing portions of the solder resist respectively covering the wire bonding pads and the solder ball pads.

The first copper plated layer is formed in accordance with an electroless copper plating process. The first copper plated layer serves as a plating lead line during the electrolytic Au plating processes for the solder ball pads and the wire bonding pads.

The second copper plated layer is an electrolytic copper plated layer, and forms the circuit patterns. Preferably, the second resist is a dry film for an Au plating process.

Preferably, the Au layer plated in accordance with the electrolytic Au—Ni plating process has a thickness of 0.5 to 1.5 μm .

In accordance with another aspect, the present invention provides a package substrate electrolytically plated with Au without using any plating lead line, comprising: a base substrate formed with a plurality of through holes; a first copper plated layer plated on predetermined portions of the base substrate and inner surfaces of the through holes; a plated pattern layer formed on the first copper plated layer; wire bonding pads formed on predetermined portions of the plated pattern layer at an upper surface of the base substrate in accordance with an electrolytic Au plating process without using any plating lead line; solder ball pads formed on predetermined portions of the plated pattern layer at a lower surface of the base substrate in accordance with an electrolytic Au plating process without using any plating lead line; and a solder resist covering the base substrate and the plated pattern layer, except for the wire bonding pads and the solder ball pads, the plated pattern layer being formed by coating a resist on the first copper plated layer, except for regions around the through holes, and forming a second copper plated layer in a semi-additive manner on portions of the first copper plated layer at which the resist is not present.

Preferably, the wire bonding pads and the solder ball pads are Au layers plated in accordance with application of current to the first copper plated layer.

Preferably, the first copper plated layer serves as a plating lead line during the electrolytic Au plating processes for the solder ball pads and the wire bonding pads.

Preferably, each of the electrolytic Au plating process forms a plated layer having a thickness of 0.5 to 1.5 μm .

In accordance with the present invention, it is possible to manufacture a package substrate without using any plating lead line because an Au layer is plated on wire bonding pads and solder ball pads in a semi-additive manner without using any plating lead line in accordance with an electrolytic Au

plating process. Accordingly, it is possible to achieve an improvement in the line density of the package substrate, while avoiding generation of noise by virtue of elimination of plating lead lines.

BRIEF DESCRIPTION OF THE DRAWINGS

The above objects, and other features and advantages of the present invention will become more apparent after a reading of the following detailed description when taken in conjunction with the drawings, in which:

FIG. 1 is a sectional view illustrating a conventional BGA package;

FIG. 2 is a plan view illustrating the package substrate plated using conventional plating lead lines;

FIGS. 3*a* to 3*i* are views respectively illustrating a conventional method for manufacturing a package substrate plated with Au using plating lead lines;

FIG. 4 is a plan view illustrating a package substrate manufactured without using any plating lead line in accordance with the present invention;

FIG. 5 is a sectional view illustrating application of current to the package substrate manufactured with using any plating lead line in accordance with the present invention;

FIGS. 6*a* to 6*k* are views respectively illustrating processes for manufacturing a package substrate without using any plating lead line in accordance with a first embodiment of the present invention;

FIGS. 7*a* to 7*f* are sectional views respectively illustrating processes for manufacturing a printed circuit board in a conventional subtractive manner;

FIGS. 8*a* and 8*b* are sectional views respectively illustrating etching profiles of the printed circuit board manufactured in the conventional subtractive manner;

FIGS. 9*a* to 9*f* are sectional views respectively illustrating processes for manufacturing a printed circuit board in a semi-additive manner in accordance with the present invention;

FIGS. 10*a* and 10*b* are sectional views respectively illustrating etching profiles of the printed circuit board manufactured in the semi-additive manner in accordance with the present invention; and

FIGS. 11*a* and 11*b* are views illustrating respective line densities of the conventional package substrate and the package substrate according to the present invention.

DESCRIPTION OF THE PREFERRED EMBODIMENTS

Now, a package substrate manufactured using an electrolytic leadless plating process without using any plating lead line and a method for manufacturing the same in accordance with each embodiment of the present invention will be described in detail.

FIGS. 6*a* to 6*k* are views illustrating processes for manufacturing a package substrate in a semi-additive manner without using any plating lead line in accordance with an embodiment of the present invention, respectively. The package substrate and its manufacturing method will be described in conjunction with FIGS. 6*a* to 6*k*.

First, a plurality of through holes, that is, via holes, 32, are formed at a base substrate 31 (FIG. 6*a*). A first copper plated layer 33 is formed to cover the entire surface of the base substrate 31 and the inner surface of each through hole 32 (FIG. 6*b*). The plating of the first copper plated layer 33 is carried out in accordance with an electroless plating process.

The first copper plated layer 33 serves as a plating lead line for plating Au on wire bonding pads and solder ball pads.

Although the base substrate according to the present invention is illustrated as consisting of a single-layer CCL structure, it may consist of a multi-layer CCL structure including a plurality of laminated CCLs. The CCL may include an epoxy substrate, and copper foils respectively bonded to upper and lower surfaces of the epoxy substrate by a conductive adhesive. The base substrate 31 is formed with an inner-layer circuit having a ground pattern or signal processing pattern in accordance with a photolithography process. The through holes, that is, via holes, 32, serve to electrically connect circuits respectively provided at upper and lower surfaces of the base substrate 31. In order to electrically connect the circuits, a copper plated film, that is, the first copper plated layer 33, is formed at the base substrate 31 in accordance with a copper plating process. In the illustrated case, the first copper plated layer 33 covers the entire surface of the base substrate 31 and the inner surface of each through hole 32.

A first resist 34 for a copper plating process is then coated over portions of the first plated layer 33 covering the upper and lower surfaces of the base substrate 31. The resist 34 is subsequently removed from regions where desired circuit patterns are to be plated, thereby partially exposing the first copper plated layer 33 (FIG. 6*c*).

Thereafter, copper is plated on the exposed portions of the first copper plated layer 33, thereby forming a second copper plated layer 35 (FIG. 6*d*). This second copper plated layer 35 is formed in accordance with an electrolytic copper plating process, and forms circuit patterns.

The remaining first resist 34, is then completely removed using a stripping solution (FIG. 6*e*). Over the resultant structure, a second resist 37 for a plating process is coated, and then removed from regions where wire bonding pads and solder ball pads are to be formed, thereby partially exposing the second copper plated layer 35 (FIG. 6*f*). Preferably, the second resist 37 is a dry film for an Au plating process.

Subsequently, portions of the first copper plated layer 33 exposed in accordance the removal of the second resist 37 are removed using an etchant (FIG. 6*g*). In FIG. 6*g*, the reference numeral 38 denotes a region where the base substrate 31 is exposed in accordance with the removal of the first copper plated layer 33. An Au layer 39 is then plated on the exposed portions of the second copper plated layer 35 corresponding to respective regions where wire bonding pads and solder ball pads are to be formed, in accordance with an electrolytic Ni—Au plating process. Preferably, the Au layer 39 has a thickness of 0.5 to 1.5 μm . In this plating process, current flows through the first copper plated layer 33. The Au layer 39 forms wire bonding pads and solder ball pads.

Thereafter, the remaining second resist 37 is completely removed using a stripping solution (FIG. 6*i*). Portions of the first copper plated layer 33 exposed in accordance with the removal of the second resist 37 are then removed using an etchant (FIG. 6*j*). In FIG. 6*j*, the reference numeral 40 denotes regions where the first copper plated layer 33 is removed.

Finally, a solder resist 41 is coated over the entire surface of the resultant structure, and then removed from regions where the Au layer 39, that is, the wire bonding pads and solder ball pads, have been formed (FIG. 6*k*). That is, the solder resist 41 is subjected to exposure and development processes so that its portions covering the wire bonding pads and solder ball pads are removed.

Thus, the package substrate electrolytically plated with Au without using any plating lead line in accordance with present invention includes: a) the base substrate **31** formed with a plurality of through holes **32**; b) the first copper plated layer **33** plated on predetermined portions of the base substrate **31** and the inner surface of each through hole **32**; c) the second copper plated layer **35** formed on the first copper plated layer **33** to form circuit patterns; d) the wire bonding pads formed on predetermined portions of the second copper plated layer **35** at the upper surface of the base substrate **31** in accordance with an electrolytic Au plating process without using any plating lead line; e) solder ball pads **39** formed on predetermined portions of the second copper plated layer **35** at the lower surface of the base substrate **31** in accordance with an electrolytic Au plating process without using any plating lead line; and f) a solder resist **41** covering the base substrate **31** and second copper plated layer **35**, except for the wire bonding pads and solder ball pads.

In accordance with the present invention, the resist **34** for a plating process is coated on the first copper plated layer **33**, except for regions around the through holes **32**, and the second copper plated layer **35** (pattern plated layer) is formed in a semi-additive manner on the first copper plated layer **33** at regions where the resist **34** is not present. The semi-additive plating process will be described hereinafter.

On the other hand, FIG. **4** is a plan view illustrating a package substrate manufactured without using any plating lead line in accordance with the present invention. Referring to FIG. **4**, it can be seen that the package substrate according to the present invention is different from the conventional package substrate of FIG. **2** in that it does not use any plating lead lines adapted to be connected to solder ball pads **20**.

FIG. **5** is a sectional view illustrating application of current to the package substrate manufactured with using any plating lead line in accordance with the present invention. Referring to FIG. **5**, the wire bonding pads and solder ball pads are plated with Au as current flows through the copper plated layer **33**, as described above.

Now, Au plating processes respectively using a conventional subtractive method and a semi-additive method according to the present invention will be described with reference to FIGS. **7** to **10**.

FIGS. **7a** to **7f** are sectional views respectively illustrating processes for manufacturing a printed circuit board in a conventional subtractive manner. FIGS. **8a** and **8b** are sectional views respectively illustrating etching profiles of the printed circuit board manufactured in the conventional subtractive manner.

In order to manufacture a printed circuit board in a conventional subtractive manner, a base substrate is first prepared which includes a base substrate core **51**, and copper foils **52** of about 12 μm formed at opposite surfaces of the base substrate core **51** (FIG. **7a**). A plurality of through holes **53** are formed at the base substrate, using a mechanical drill (FIG. **7b**). In this case, an etching process may be carried out to reduce the thickness of each copper foil **52** from about 12 μm to a thickness of 3 to 7 μm .

Thereafter, an electroless copper layer **54** having a thickness of about 0.5 μm is formed on the entire surface of the base substrate and the inner surface of each through hole **53** (FIG. **7c**). Also, an electrolytic copper plated layer **55** having a thickness of about 15 μm is formed on the electroless copper layer **54** in accordance with an electrolytic plating process (FIG. **7d**).

Dry films **56** having a thickness of about 15 μm are then laminated to tent upper and lower ends of each through hole

53 (FIG. **7e**). The resultant structure is subsequently subjected to exposure and development processes, and the electroless copper plated layer **54** and electrolytic copper plated layer **55** are then removed, except for their portions corresponding to respective regions where the dry films are laminated, using an etchant (FIG. **7f**).

FIGS. **8a** and **8b** show cross sections of the printed circuit board manufactured in accordance with the processes of FIGS. **7a** to **7f**, respectively. FIG. **8a** shows a laminated structure including the base substrate core **51**, the copper foil **52** of about 5 μm , the electroless copper plated layer **54** of about 0.5 μm , the electrolytic copper plated layer **55** of 15 μm , and the dry film **56** of about 15 μm . FIG. **8b** shows a structure obtained after etching the side walls of the laminated structure shown in FIG. **8a**. Referring to FIG. **8b**, it can be seen that it is difficult to form micro circuits because the side walls are deeply etched.

On the other hand, FIGS. **9a** to **9f** are sectional views respectively illustrating processes for manufacturing a printed circuit board in a semi-additive manner in accordance with the present invention. FIGS. **10a** and **10b** are sectional views respectively illustrating etching profiles of the printed circuit board manufactured in the semi-additive manner in accordance with the present invention.

In order to manufacture a printed circuit board in a semi-additive manner in accordance with the present invention, a base substrate is first prepared which includes a base substrate core **61** (FIG. **9a**). A plurality of through holes **62** are formed at the base substrate, using a mechanical drill (FIG. **9b**).

Thereafter, an electroless copper layer **63** having a thickness of about 0.5 μm is formed on the entire surface of the base substrate and the inner surface of each through hole **62** (FIG. **9c**). Subsequently, dry films **64** are laminated on the electroless copper layer **63**, except for regions around the through holes **62**, and then subjected to exposure and development processes (FIG. **9d**). An electrolytic copper layer **65** having a thickness of 15 to 20 μm is then formed on the electroless copper layer **63**, except for regions where the dry films **64** are laminated (FIG. **9e**). The resultant structure is subjected to exposure and development processes, the dry films (**64**) are stripped using a stripping solution, and then the electroless copper layer **63** is etched in accordance with a flash etching process (FIG. **9f**).

In the printed circuit board manufactured in the subtractive manner of FIGS. **7a** to **7f**, the etching process is carried out after forming the electrolytic copper plated layer **55** on the electroless copper plated layer **54**, and then laminating the dry films **56**. In the printed circuit board manufactured in the semi-additive manner of FIGS. **9a** to **9f**, however, the flash etching process is carried out after laminating the dry films **64** on the electroless copper plated layer **63**, and then forming the electrolytic copper plated layer **65**.

FIGS. **10a** and **10b** show cross sections of the printed circuit board manufactured in accordance with the processes of FIGS. **9a** to **9f**, respectively. FIG. **10a** shows a laminated structure including the base substrate core **61**, the electroless copper plated layer **63** of about 0.5 μm , the dry films **64** of about 25 μm , and the electrolytic copper plated layer **65** of 20 μm laminated between the dry films **64**. FIG. **10b** shows a structure obtained after carrying out a stripping and flash etching process for the laminated structure shown in FIG. **10a**. Referring to FIG. **10b**, it can be seen that it is possible to form micro circuits because the side walls are not etched.

The trace width deviation range in the conventional subtractive method is $\pm 15 \mu\text{m}$, whereas the trace width

deviation range in the semi-additive method according to the present invention is $\pm 5 \mu\text{m}$. Therefore, it is possible to achieve shallow etching.

Accordingly, it is possible to achieve an improvement in line density in the package substrate manufactured without using any plating lead line and the manufacturing method thereof in accordance with the present invention.

FIGS. 11a and 11b are views illustrating respective line densities of the conventional package substrate and the package substrate according to the present invention. In the conventional package substrate shown in FIG. 11a, solder ball pads 72a formed at its package substrate 71 have a ball pad pitch A defined between the centers of adjacent ones thereof. In FIG. 11a, the reference numeral 73 denotes a plating lead line. In the package substrate of the present invention shown in FIG. 11b, solder ball pads 72a formed at its package substrate 71 have a ball pad pitch B defined between the centers of adjacent ones thereof. Referring to FIGS. 11a and 11b, the ball pad pitch B is less than the ball pad pitch A by, for example, about 0.1 to 0.15 mm. That is, as compared to the conventional package substrate, the package substrate of the present invention can form an increased number of solder ball pads at the same area because it dispenses with the plating lead line 73 shown in FIG. 11a. Accordingly, an improvement in line density is achieved in accordance with the present invention.

As apparent from the above description, the present invention can improve the electrical characteristics of a package substrate such as a BGA package substrate or a CSP package substrate by carrying out an electrolytic Au plating process for the package substrate without using any plating lead line. Also, the present invention improves the design freedom of circuits by virtue of dispensing with plating lead lines. It is also possible to reduce the pitch of ball pads by about 0.1 to 0.15 mm, as compared to the ball pad pitch in conventional cases. Thus, package substrates having highly integrated circuits can be manufactured.

Although the preferred embodiments of the invention have been disclosed for illustrative purposes, those skilled in the art will appreciate that various modifications, additions and substitutions are possible, without departing from the scope and spirit of the invention as disclosed in the accompanying claims.

In accordance with the present invention, it is possible to prevent generation of signal noise caused by residue of plating lead lines for an electrolytic Au plating process, thereby achieving an improvement in the electrical characteristics of a package substrate.

In accordance with the present invention, it is also possible to improve the design freedom (flexibility) of circuits by virtue of dispensing with plating lead lines. Accordingly, there is an advantage in manufacturing package substrates having highly integrated circuits.

What is claimed is:

1. A method for manufacturing a package substrate without using any plating lead line, comprising the steps of:

- a) plating copper on all surfaces of a base substrate formed with a plurality of through holes and inner surfaces of the through holes, thereby forming a first copper plated layer;
- b) coating a first resist for a plating process over the first copper plated layer, partially removing the first resist, thereby exposing predetermined portions of the first copper plated layer respectively corresponding to regions where circuit patterns are to be plated;
- c) plating copper on the exposed portions of the first copper plated layer, thereby forming a second copper plated layer;
- d) stripping the first resist remaining on the first copper plated layer;
- e) coating a second resist for a plating process over all surfaces of a structure obtained after completion of the step (d), and removing the second resist from regions where wire bonding pads and solder ball pads are to be formed;
- f) removing portions of the first copper plated layer exposed without being covered by the second resist, by use of an etchant;
- g) forming an Au layer on portions of the second copper plated layer exposed without being covered by the second resist in accordance with an electrolytic Ni—Au plating process, thereby forming the wire bonding pads and the solder ball pads;
- h) removing the second resist remaining on the structure by use of a stripping solution;
- i) removing portions of the first copper plated layer exposed in accordance with the removal of the second resist, by use of an etchant; and
- j) coating a solder resist over all surfaces of a structure obtained after completion of the step (i), and removing portions of the solder resist respectively covering the wire bonding pads and the solder ball pads.

2. The method according to claim 1, wherein the first copper plated layer is formed in accordance with an electrolytic copper plating process.

3. The method according to claim 1, wherein the second copper plated layer is an electrolytic copper plated layer, and forms the circuit patterns.

4. The method according to claim 1, wherein the second resist is a dry film for an Au plating process.

5. The method according to claim 1, wherein the Au layer plated in accordance with the electrolytic Au—Ni plating process has a thickness of 0.5 to 1.5 μm .

6. The method according to claim 1, wherein the first copper plated layer serves as a plating lead line during the electrolytic Au—Ni plating process for the wire bonding pads and the solder ball pads.

* * * * *