

E. R. Beardsley,

Water Wheel.

NO. 108436.

Patented Oct. 18. 1870.

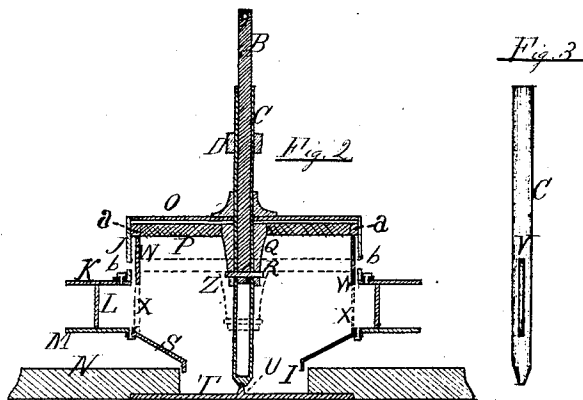
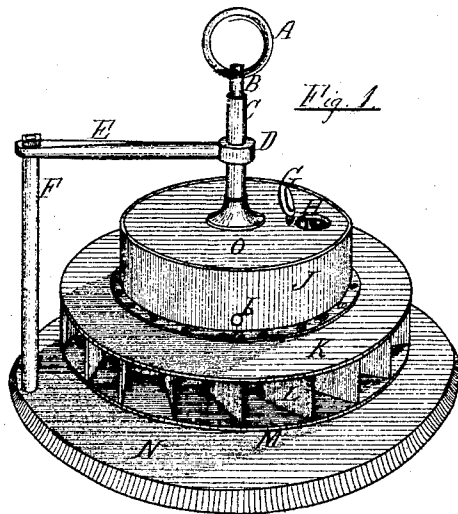

Witnesses.

A. H. Kelley
H. G. Swan

Inventor.

Edwin R. Beardsley
By his attorney
G. A. Chapin

United States Patent Office.

EDWIN R. BEARDSLEY, OF AROMA, ILLINOIS.

Letters Patent No. 108,436, dated October 18, 1870; antedated October 15, 1870.

IMPROVEMENT IN TURBINE WATER-WHEELS.

The Schedule referred to in these Letters Patent and making part of the same.

To all whom it may concern:

Be it known that I, EDWIN R. BEARDSLEY, of Aroma, in the county of Kankakee and State of Illinois, have invented an Improvement on a Turbine Water-Wheel, patented by me on the seventh day of December, eighteen hundred and sixty-nine; and I do hereby declare that the following is a full, clear, and exact description thereof, which will enable those skilled in the art to make and use the same, reference being had to the accompanying drawing and letters marked thereon, making a part of this specification, in which—

Figure 1 is a perspective representation of my improved wheel.

Figure 2, a section of the same.

Figure 3, an elevation of the casing of the gate-rod.

The nature of the present invention consists—

First, in the novel construction of a conical breakwater, attached to the inner edge of the lower rim of the wheel, and used to reduce the pressure of water resting on the wheel, and to prevent leakage.

Second, in attaching a flange, to the top part of the outer periphery of the cylindrical gate, whereby water entering ports in the dome or upper part of the wheel will come in contact with said flange with sufficient force to suspend the gate, as against its own gravity, and prevent friction of the gate-rod, as the whole is hereinafter fully described.

N represents the bottom of a flume;

K L M is the wheel;

J, the dome; and

Q P W, the gate of the wheel, shown in the patent above referred to, the several parts being so arranged that the water is taken from the periphery of the wheel and discharged through the bottom.

In the aforesaid patent, the breakwater is placed near the periphery of the wheel, and has an annular form, inside of which the wheel runs.

But that construction and arrangement is objectionable in the fact that there is too great a pressure of water on the wheel, and too great a liability of leakage in consequence of the size of the opening below.

To remedy the above objection, I have placed below, and attached to the lower face of the wheel,

what I term a breakwater, S, it having an inverted conical form, and allowing the water to pass freely from the buckets through the opening at the bottom; while at the same time the rotary current is not broken so as to retard the forward motion of the wheel. This construction and arrangement is such that the water ceases to act on the buckets after it enters the breakwater.

The bottom of the breakwater is provided with a narrow flange, I, projecting past the upper edge of the bottom N of flume, said flange running closely to the bottom S, and guiding the water through it.

In the aforesaid patent, the upper rim of the wheel, shown at K in the present drawing, was made to extend inward to the cylindrical gate W, by means of which the latter necessarily had to be operated against its own gravity.

In the present invention, I obviate the last-named difficulty by removing that part of the upper rim which projected inside of the dome J, and attaching an annular flange *a a* to the top part of the outer periphery of the gate W, as shown in fig. 2, and by making ports, *b*, through the dome, just above the rim K. This arrangement is such that the water enters the ports, passes upward and bears against said flange *a a*, with sufficient force to balance or suspend the gate W, thus almost relieving the gate-rod B from friction as it moves in the cylinder C.

Having thus described my invention,

What I claim, and desire to secure by Letters Patent of the United States, is—

1. The conical breakwater S, constructed as described, and combined with the wheel to lessen the pressure of water and prevent leakage, as set forth.

2. The annular flanges on the outer periphery of the gate W, to operate inside of the dome J in combination with the ports *b*, the whole being arranged to balance the gate as against its own gravity, as and for the purpose shown and specified.

EDWIN R. BEARDSLEY.

Witnesses:

J. H. SKELLY,
H. Y. SWAN.