



- (51) International Patent Classification:
B65D 25/08 (2006.01) B65D 77/04 (2006.01)
B65D 81/32 (2006.01)
- (21) International Application Number:
PCT/AU2015/050143
- (22) International Filing Date:
31 March 2015 (31.03.2015)
- (25) Filing Language: English
- (26) Publication Language: English
- (30) Priority Data:
2014901146 31 March 2014 (31.03.2014) AU
2014904833 28 November 2014 (28.11.2014) AU
- (72) Inventor; and
- (71) Applicant : O'SUGHRUE, Shane Dominic [AU/AU]; 4
Mystic Court, Eumemmerring, Victoria 3177 (AU).
- (72) Inventors: JARRATT, Kyle; c/- 103 Howard St, North
Melbourne, Victoria 3051 (AU). KARTOV, Vladimir D.;

c/- 36 Hristo Popovich st., Entrance B floor 4 ap. 17, 9000 Varna (BG).

- (74) Agent: DAVIES COLLISON CAVE; Level 15, 1 Nicholson Street, Melbourne, Victoria 3000 (AU).
- (81) Designated States (unless otherwise indicated, for every kind of national protection available): AE, AG, AL, AM, AO, AT, AU, AZ, BA, BB, BG, BH, BN, BR, BW, BY, BZ, CA, CH, CL, CN, CO, CR, CU, CZ, DE, DK, DM, DO, DZ, EC, EE, EG, ES, FI, GB, GD, GE, GH, GM, GT, HN, HR, HU, ID, IL, IN, IR, IS, JP, KE, KG, KN, KP, KR, KZ, LA, LC, LK, LR, LS, LU, LY, MA, MD, ME, MG, MK, MN, MW, MX, MY, MZ, NA, NG, NI, NO, NZ, OM, PA, PE, PG, PH, PL, PT, QA, RO, RS, RU, RW, SA, SC, SD, SE, SG, SK, SL, SM, ST, SV, SY, TH, TJ, TM, TN, TR, TT, TZ, UA, UG, US, UZ, VC, VN, ZA, ZM, ZW.
- (84) Designated States (unless otherwise indicated, for every kind of regional protection available): ARIPO (BW, GH, GM, KE, LR, LS, MW, MZ, NA, RW, SD, SL, ST, SZ, TZ, UG, ZM, ZW), Eurasian (AM, AZ, BY, KG, KZ, RU, TJ, TM), European (AL, AT, BE, BG, CH, CY, CZ, DE,

[Continued on next page]

(54) Title: CONTAINER FOR HOLDING AND COMBINING BEVERAGE COMPONENTS TO PRODUCE A BEVERAGE DRINKABLE FROM A VESSEL THEREOF

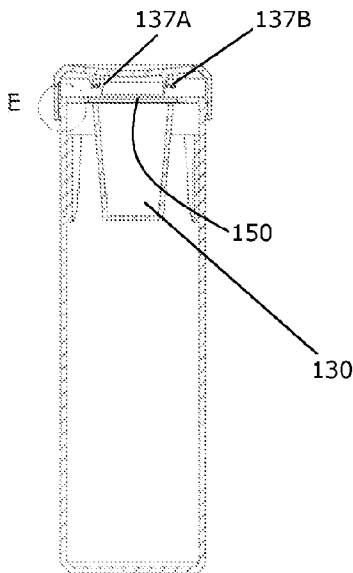

SECTION D-D
SCALE 1:1

FIGURE 10B

(57) Abstract: There is disclosed a beverage container comprising: a drinking vessel containing a consumable liquid; and a receptacle, which is supported over an interior region of the vessel and holds a substance that is to be added to the liquid, in a manner such that the substance is isolated from the liquid, the container being operable to effect release of the receptacle such that it descends in the liquid and said substance is thus released into the liquid whereby there is produced a beverage drinkable from the vessel. There is also disclosed method of assembling such a container.

WO 2015/149126 A1

DK, EE, ES, FI, FR, GB, GR, HR, HU, IE, IS, IT, LT, **Published:**
LU, LV, MC, MK, MT, NL, NO, PL, PT, RO, RS, SE, — *with international search report (Art. 21(3))*
SI, SK, SM, TR), OAPI (BF, BJ, CF, CG, CI, CM, GA,
GN, GQ, GW, KM, ML, MR, NE, SN, TD, TG).

Container for holding and combining beverage components to produce a beverage drinkable from a vessel thereof

Related Applications

5 The present application claims priority from Australian provisional patent application no. 2014901146, filed 31 March 2014, and Australian provisional patent application no. 2014904833, filed 28 November 2014, each of which is entitled *Container for holding and combining beverage components to produce a beverage drinkable from the container* and the contents of which are incorporated herein by reference in their entirety.

10

Field of the Invention

The present invention relates to a container for holding and combining beverage components to produce a beverage which can be drunk from the container.

15 The invention has particular, though not exclusive, application to drinks akin to a *depth charge* or *bomb shot*, which is a drink made by mixing two beverage constituents, one constituent being held in a relatively large vessel, typically a glass, and the other being held in a relatively small vessel, typically a shot glass. The smaller vessel is dropped into the larger vessel such that the constituents mix. Generally, the constituent held in the
20 smaller vessel is alcoholic. The constituent held in the larger vessel can be alcoholic or non-alcoholic. The resulting drink is often consumed as quickly as possible ("chugged").

Such drinks often hold considerable consumer appeal.

25 Summary of the Invention

According to a first aspect of the present invention, there is provided a beverage container comprising:

a drinking vessel containing a consumable liquid; and

30 a receptacle, which is supported over an interior region of the vessel and holds a substance that is to be added to the liquid, in a manner such that the substance is isolated from the liquid,

- 2 -

the container being operable to effect release of the receptacle such that it descends in the liquid and said substance is thus released into the liquid whereby there is produced a beverage drinkable from the vessel.

- 5 In the container according to the preferred embodiments of the invention, the vessel is sealed whereby, before opening of the container, said consumable liquid cannot escape from the container.

The container may be configured such that opening thereof effects the release of the
10 receptacle. Alternatively, the container may be configured such that an operation other than opening of the container effects the release of the receptacle. Said operation other than opening of the container may comprise, for example, an independent operation to effect said release.

- 15 In one embodiment of the invention, the container is configured such that an operation between one step in opening of the container and another step in opening of the container effects said release. Preferably, the container of this embodiment comprises a closure member, e.g. a lid member, which is twistable or turnable so as to be thereafter removeable or otherwise repositionable to permit drinking of the beverage from the vessel, whereby
20 said one step comprises twisting or turning of the closure member and the other step comprises removing or otherwise repositioning the closure member to permit said drinking. Preferably, the container of this embodiment is configured such that the operation that effects said release is application of a force to the closure member. Preferably, the closure member is configured such that said force can be applied to a top of
25 the closure member in a direction towards a base of the container.

The drinking vessel may comprise, for example, a can, or a bottle, glass or jar which may be formed, for example, from glass or plastic.

- 30 Preferably, said substance is or includes a liquid. Alternatively, the substance may be in solid form; for example, it may comprise a powder releasable into the liquid.

- 3 -

In a preferred embodiment of the invention, the substance comprises an alcohol-containing liquid. The consumable liquid may comprise a mixer for the alcohol-containing liquid. Alternatively, the consumable liquid may comprise an alcoholic beverage, such as, for
5 example, beer or cider.

Preferably, the drinking vessel comprises a wall that can be seen through such that the descent of the receptacle in and/or release of the substance into the consumable liquid can be observed. In one embodiment of the invention, the vessel comprises a bottle, which
10 may be, for example, a glass bottle or a plastic bottle. The bottle may have a wall which is transparent or otherwise able to be seen through. In another embodiment of the invention, the vessel comprises a can, which may be formed from metal such as, for example, aluminium or steel. The can may be windowed such that the descent of the receptacle in and/or release of the substance into the consumable liquid can be observed. The can may
15 be provided with one or more windows whereby the descent and/or substance release can be observed. The window(s) may be formed, for example, from plastic or glass.

Alternatively, the container may be configured such that the descent and/or substance release can be observed through an opening created by opening of the container, in which
20 case it may be that the vessel does not have any wall which can be seen through, as may be preferable (including from a manufacturability perspective) where the vessel comprises a can.

Preferably, said substance and said consumable liquid differ in appearance whereby the
25 release of the former into the latter is observable or the observability of said release is enhanced.

Preferably, the receptacle is configured in the form of a cup or glass. In a preferred embodiment of the invention, the receptacle comprises or is configured in the general form
30 of a shot glass, or at least has a storage capacity similar to that of a shot glass (which capacity differs from one country to another but is generally between 20mL and 60mL).

- 4 -

The shot glass may be formed from glass or plastic. The container may be configured such that a torque is imparted to the receptacle whereby it rotates during the descent thereof in the liquid. The receptacle may be shaped such that the liquid imparts said torque. The receptacle or shot glass may, for example, be configured with at least one fin via which the torque can be imparted to the receptacle. The receptacle or shot glass can be configured in "tornado" form, i.e. can be shaped in the form of, or comprise a "tornado" shot glass, whereby to rotate during its descent. The rotation is preferably about an upright axis of the receptacle. The upright axis may be a central axis of the receptacle or an axis which is radially offset from but parallel to the central axis.

5

The receptacle or shot glass may be pointy in a downward direction.

The receptacle or shot glass may be grooved.

10

15 The receptacle or shot glass may have an aesthetic or decorative appearance; e.g., it may be configured in the form of a love heart.

In a preferred embodiment of the invention, the receptacle is sealed and the container is operable to effect unsealing of the receptacle. The container may include a seal applied to or over a mouth of the receptacle. Said seal may comprise a film. Preferably, the seal is connected to a closure member of the container and/or to a mechanism for opening the closure member, such that operation of the closure member deactivates the seal. That operation may comprise opening of the container or may be effected between one step in opening of the container and another step in opening of the container. The seal may be connected to the closure, closure member or closure mechanism either directly or indirectly.

20

25

30 Preferably, the container includes an interconnection between the receptacle and a part of the container and is configured such that the release of the receptacle is effected by breaking, releasing or otherwise deactivating the interconnection. The interconnection may anchor the receptacle to said part of the container and/or to another part of the

- 5 -

container.

Preferably, the receptacle depends or hangs from said part of the container via the interconnection.

5

Said interconnection may comprise a rotatably releasably interconnection. The rotatably releasable interconnection may comprise a threaded interconnection. In a preferred embodiment of the invention, said receptacle includes a thread and said part of the container includes a thread engaged with the thread of the receptacle, whereby said
10 threaded interconnection is defined, and one of said receptacle and said part of the container is rotatable relative to the other of said receptacle and said part of the container such that the interconnection is or can be broken, released and/or deactivated whereby said release of said receptacle is or can be effected.

15 Preferably, said part of the container is a closure or closure member of the container.

Preferably, the container is openable via rotation of the closure or closure member such that the interconnection is or can be broken, released and/or deactivated whereby the release of the receptacle is caused.

20

Preferably, the receptacle is interlockingly engaged with the vessel so as to be precluded from rotating during said rotation such that the interconnection is or can be broken or otherwise deactivated via said rotation. In a preferred embodiment of the invention, the container includes a locking member supported from the vessel and engaging the
25 receptacle so as to effect the interlocking engagement between the receptacle and vessel. The locking member may comprise an annular member supported from a side wall of the vessel and surrounding the receptacle. Preferably, the annular member forms a fit around the receptacle to preclude it from rotating during said rotation. Preferably, the locking member sits on a shoulder arrangement or shelf arrangement extending around an interior
30 section of the vessel so as to be interlockingly engaged with the vessel and thus precluded from rotating during said rotation. Preferably, the shoulder or shelf arrangement extends

- 6 -

around a side wall of the vessel inside the vessel. Preferably, the vessel engages the locking member in a manner such that it resists rotation thereof in the direction of said rotation, whereby the interlocking engagement between the receptacle and the vessel is defined, but does not resist rotation of the locking member in the opposite rotational
5 direction.

According to a second aspect of the present invention, there is provided a method of assembling said beverage container, wherein an assembly which comprises the receptacle and the closure or closure member and in which the receptacle and the closure or closure
10 member are interconnected is, during securement of that assembly to an assembly which comprises the vessel and the locking member and in which the locking member is supported from the vessel, rotated relative to the vessel, such that the receptacle turns the locking member relative to the vessel.

15 The interconnection may comprise one or more connecting elements. The or each connecting element may, for example, comprise a cord, wire, strip or string. The interconnection may comprise, or be defined by, said seal.

Preferably, the interconnection between the receptacle and said part of the container is
20 sealed whereby escape, through the interconnection, of said substance from an interior of the receptacle, or of said liquid from an interior of the vessel, is precluded.

The interconnection may connect to a closure or closure member of the container and/or to a mechanism for opening the closure or closure member, such that displacement of the
25 closure or closure member, e.g. to open, as part of opening, or between steps effected to open, the container effects the breakage or deactivation of the interconnection. The interconnection may hold the receptacle, preferably a mouth of the receptacle, against a portion of the container and be arranged such that it is tensioned upon said displacement or upon opening of the receptacle, or upon said operation other than opening of the container
30 being effected, whereby to be broken or otherwise deactivated such that the release of the receptacle is effected.

- 7 -

Said portion of the container may be defined by a ceiling in or roof of the container. Alternatively, the portion may define, or be positioned at, a boundary between an upper zone and a lower zone in the interior of the container, or may be positioned where such
5 upper and lower zones meet, substantially all of the liquid preferably occupying the lower zone at least when the container is orientated upright. Preferably, the portion is then formed with an opening therethrough, via which the interconnection connects to the receptacle.

10 In one embodiment of the invention, said portion is defined by said part of the container. In another embodiment of the invention, a seal, which may comprise a film, is applied over a mouth of the receptacle and is connected to a closure member of the receptacle via said interconnection, and the container is configured such that displacement or removal of the closure member to open, as part of opening, or between steps effected to open, the
15 container tensions the interconnection, thereby breaking or otherwise deactivating it and thus effecting the release of the receptacle. In the latter embodiment, said portion may be defined by a neck of the vessel, which vessel may comprise a bottle. The receptacle may depend or hang from the closure member via the interconnection.

20 The container may include a member arranged so as to engage the receptacle, thereby to exert a force on it and thus to break, release or otherwise deactivate the interconnection. Preferably, that member forms a part of or is supported from the vessel. In one embodiment of the invention, that member extends from a closure member of the vessel or container so as to exert said force, possibly by pushing the receptacle (preferably a base
25 thereof), when the closure member is displaced to open the vessel or container. In another embodiment of the invention, that member extends from a wall (preferably a side wall) of the vessel so as to exert said force, possibly by pushing the receptacle (preferably a side wall thereof), when a closure member of the vessel is rotated to open, as part of opening, or between steps effected to open the vessel. The force-exerting member may comprise a
30 pusher.

- 8 -

In a preferred embodiment of the invention, the container includes a closure which comprises a first component attached to the vessel and a second component attached to the first component and movable relative thereto, the receptacle is attached to one of the components and the container is configured such that movement of the second component
5 relative to the first component effects the release the receptacle and the substance.

Preferably, said one component is the first component.

Preferably, said one component is configured with a hole therethrough and said container
10 includes a seal, such as a film, which is attached to said receptacle, so as to close an opening thereinto, and which is attached to said one component, so as to close said hole, and the container is configured such that movement of the second component relative to the first component causes the seal to be broken or otherwise deactivated, such that the receptacle is released from said one component and descends in the liquid and said
15 substance is thus released into the liquid whereby there is produced said beverage. Preferably, the other component comprises at least one seal-engaging member arranged so as to be received into the hole to engage the seal and thereby to effect breakage or deactivation thereof during said movement. Preferably, said at least one seal-engaging member comprises a member arranged to effect breakage or deactivation of the seal such
20 that the receptacle is released from said one component and thus descends in said liquid. Preferably, the member arranged to effect breakage or deactivation of the seal such that the receptacle is released from said one component is configured so as to cut, circumcise or otherwise break the seal radially outward of a portion, such as a rim, of the receptacle such that the release of the receptacle is effected. Preferably, said at least one seal-engaging
25 member comprises a member arranged to effect breakage or deactivation of the seal such that said substance is released from the receptacle. Preferably, the member arranged to effect breakage or deactivation of the seal such that said substance is released from the receptacle is configured so as to cut or otherwise break the seal radially inward of a portion, such as a rim, of the receptacle such that the release of the substance is effected.
30 Preferably, the member arranged to effect breakage or deactivation of the seal such that said substance is released from the receptacle is configured whereby the breakage or

- 9 -

cutting at the radially inward position is such that a portion of the seal remains unbroken after that breakage or cutting, to anchor a cut or broken part of the seal to the released receptacle; that member may, for example, comprise a blade in the form of an incomplete or otherwise interrupted closed shape, such as a circle. Preferably, at least one said seal-
5 engaging member comprises a blade.

Preferably, the container is configured such that said movement is along a substantially upright axis. Preferably, the container is configured such that said movement is downward movement. Preferably, the first component is rotatable, relative to the second component,
10 from a first position, in which said movement is precluded, to a second position, in which said movement is permitted. Preferably, said components are configured such that, during said movement along said substantially upright axis rotation of the first component relative to the second component is precluded. Preferably, said components are configured so as to be, when said first component is not in said second position, interlocked in a manner
15 precluding said movement but permitting the rotation, and so as to permit, when said first component is in said second position, said movement. Preferably, said components are configured such that, when said first component is in said second position further rotation of the first component relative to the second component in a direction from first position to the second position is precluded. Preferably, said components are configured such that the
20 first component is releasable from the second component when in said second position.

Preferably, the first and second components are configured with at least one radial projection and at least one mating circumferential channel into which a respective said projection is received such that the first component is retained to the second component in
25 a manner precluding said movement, the rotation of the first member causing relative movement between the projection(s) and the circumferential channel(s). Preferably, arranged at an end of the or each circumferential channel is an axial channel such that a respective said projection is received thereinto upon the first component reaching said second position, whereby relative axial movement between the projection(s) and axial
30 channel(s), and thus said movement along the substantially upright axis, is permitted. Preferably, the channels are arranged such that, upon the first component reaching said

- 10 -

second position, continued rotation of the first component relative to the second component, beyond said second position, is precluded. Preferably, the circumferential and axial channels are arranged such that, upon the first component reaching said second position, continued rotation of the first component relative to the second component,
5 beyond said second position, is precluded. Preferably, the circumferential and axial channels are arranged such that, during said movement along the substantially upright axis, rotation of the first component relative to the second component is precluded. Preferably, the or each axial channel is open at an end thereof, permitting release of the first component from the second component by displacement of the first component in a
10 direction opposite to that of said movement along the substantially upright axis.

Brief Description of the Drawings

The invention is described, by way of non-limiting example only, with reference to the accompanying drawings, in which:

15

Figures 1A and 1B are schematic perspective views showing a beverage container according to a first preferred embodiment of the invention in closed and open conditions respectively;

20 Figures 2A and 2B are schematic perspective views showing a beverage container according to a second preferred embodiment of the invention in closed and opened conditions respectively;

Figures 3A and 3B are schematic perspective views showing a beverage container
25 according to a third preferred embodiment of the invention in closed and opened conditions respectively;

Figures 4A and 4B are schematic perspective views showing a beverage container according to a fourth preferred embodiment of the invention in closed and opened
30 conditions respectively;

- 11 -

Figures 5A and 5B are schematic perspective views showing a beverage container according to a fifth embodiment of the invention in closed and open conditions respectively;

- 5 Figure 6A is a perspective view of a beverage container according to a sixth embodiment of the invention in a closed condition;

Figure 6B is an exploded view showing the container of the sixth embodiment;

- 10 Figure 6C is a perspective inverted view of a lid of the container of the sixth embodiment;

- Figures 6D to 6G are underneath, perspective, side elevation and front elevation (respectively) views of an assembly forming part of the container of the sixth embodiment, the assembly comprising an inner component of the lid, a liquid-containing shot glass and
15 a film via which the shot glass is held to the second component;

Figure 7 is a cutaway elevation view of the container of the sixth embodiment prior to operation/opening thereof;

- 20 Figures 8A to 8C are schematic views showing the configuration depicted in Figure 7;

Figure 9 shows rotation of the first component of the lid, constituting a first step in opening/operation of the container of the sixth embodiment;

- 25 Figures 10A to 10C are schematic views showing the configuration of the container of the sixth embodiment immediately after the first step is complete;

Figure 11 represents manual downward striking of an outer component of the lid, to effect a second step in the opening/operation of the container of the sixth embodiment;

30

Figures 12A to 12C are cutaway elevation views showing successive stages of the second

- 12 -

step;

Figure 13A to 13C are schematic views showing the configuration of the container of the sixth embodiment wherein the outer component has been fully downwardly displaced to effect release of the shot glass;

Figures 14A and 14B are schematic views showing the configuration of the container of the sixth embodiment when the outer component has returned to its original position;

Figure 15 depicts removal of the lid outer component of the container of the sixth embodiment to permit the thus-mixed beverage to be consumed;

Figures 16A and 16B are upper and lower exploded perspective views, respectively, showing details of a beverage container according to a seventh embodiment of the invention;

Figures 17A and 17B are perspective views of first and second components, respectively, of a lid of the container of the seventh embodiment;

Figures 18A and 18B are perspective and cross-sectional views showing details of an assembly comprising the first and second lid components, a shot holder and a shot holder lid of the container of the seventh embodiment;

Figure 19 is a perspective view of the container of the seventh embodiment in a starting configuration thereof;

Figures 20A and 20B are perspective views showing a vessel and ratchet-type shot holder holding mechanism of a beverage container according to an eighth embodiment of the invention;

30

Figures 21A, 21B and 21C are perspective views of the vessel, a locking element of the

- 13 -

ratchet mechanism and the shot holder of the container of the eighth embodiment;

Figure 22 is a perspective view showing a lid of the container of the eighth embodiment;
and

5

Figures 23A and 23B are cross-sectional views showing the container of the eighth embodiment in a starting configuration and the configuration it assumes when the shot holder thereof is deployed.

10 Detailed Description of the Preferred Embodiments of the Invention

In each of the preferred embodiments of the invention as described herein with reference to the accompanying drawings there is provided a beverage container which includes a drinking vessel, comprising a can, bottle or glass, holding a main liquid constituent, and a receptacle supported over an interior region of the vessel and holding another liquid
15 constituent that is to be added to the main constituent, the container being operable to effect release of the receptacle such that it descends in the vessel and the constituents thus combine to form a beverage drinkable from the vessel. The structural components of the container in each embodiment are preferably formed from suitable food grade material(s), e.g. plastics material(s).

20

A container 1 according to a first preferred embodiment of the invention is shown in Figures 1A and 1B. The container 1 includes a drinking vessel 20 in the form of a can, which holds a first drink constituent 21 comprising a mixer, and a receptacle 30 in the form of a shot glass, which holds a second drink constituent comprising an alcoholic drink such
25 as a liqueur or spirit. The can may be formed from aluminium or tin-plated steel. The can is largely the same as a conventional drink can but includes a viewing window 22, incorporated into the metal side wall thereof, extending substantially throughout the depth of the liquid 21, through which the liquid 21 can be seen. The window may be plastic or glass.

30

The top wall or roof 23 of the can is configured with a closure mechanism in the form of a

- 14 -

conventional ring-pull or stay-tab closure mechanism, comprising a pull-ring lever 24, a rivet 25 securing the lever to the can top wall, and a displaceable portion 26 of the top wall delineated by a score line 27 at which it can be broken away from a surrounding portion of the top wall by operation of the lever and bent into the can whereby there is formed an opening over which a consumer can place his or her mouth to drink from the container 1. A rim 32 of the shot glass 30 is received sealingly against an interior face of the can top wall 23, whereby the mouth of the shot glass 30 is sealed and the contents of that glass thus isolated from the liquid 21. To this end, the can top wall 23 may be provided with an indication seal, or an interior lining comprising sealant material, which forms a seal with the rim 32 and releasably bonds it to the underside of the top wall, thereby anchoring the shot glass 30 to the top wall. Alternatively or additionally, the seal may be defined by a patch of sealant applied to the top wall underside and/or a bead of sealant applied around the shot glass rim.

As will be clear from Figure 1A, the rim 32 is fixed to the underside radially outward of the score line 27 and rivet 25. A pusher 34, which in the present embodiment takes the form of a rod, extends from an underside of the displaceable wall portion 26 and into the shot glass 30, terminating at or near the base of the shot glass 30. The rod may be formed from metal, which may be the same metal as that from which the can 20 is formed, or plastic. When the container 1 is opened, by operating the ring-pull lever 24, the displaceable portion 26, as a result of its downward displacement, urges the pusher 34 against the shot glass base, with sufficient force to overcome the bond, whereby the shot glass 30 is no longer supported and therefore descends into the liquid 21 such that the liquid therein is released in the can and the two liquids thus mix. The descent of the shot glass 30 and mixing of the liquids can be observed through the window 22.

Without departure from the invention, in an alternative to the container 1, the shot glass rim 32 and the seal formed therewith can cross the score line 27 such that a section of the rim 32 and, correspondingly, a section of the seal underlie the displaceable portion 26, such that that portion, when displaced downwardly, urges the section of the rim 32 downwardly, such that the seal is broken and the descent of the shot glass 30 is thus

- 15 -

effected, the pusher 34 thus being omitted from the alternative.

A container 1' according to a second preferred embodiment of the invention is shown in Figures 2A and 2B. The container 1', like container 1, comprises a can configured with a viewing window 24. The closure in this embodiment comprises a displaceable portion 26 of the top wall 23, delineated by an arcuate score line 27 at which an edge of the displaceable portion can be separated from part of the top wall which surrounds it, and a finger-engageable or pinch-grippable part 24, such as a tab, which the consumer can pull to break the top wall material at the arcuate score line and bend or fold the displaceable portion upwardly whereby the drinking opening, is formed. The line 28 at which the bending is effected, shown in Figure 2B, is a further score line, facilitating bending or folding of the displaceable portion 26 through an obtuse angle, so it does not obstruct access to the drinking opening (as shown in Figure 2B), or permitting the bending or folding to cause breakage of the top wall material, at the further score line 28, such that the displaceable portion 26 is separated entirely from the remainder of the can 20.

The container 1' includes a partition 40, which may be formed, for example, from plastic, adjacent the upper end of the can 20. The perimeter of the partition 40 is complementary in configuration to the interior cross section of the can and is sealingly attached all the way therearound to the interior face of the can side wall. The partition 40 is formed with a hole therethrough. Applied to the mouth of the shot glass is a film 50 which is releasably attached to the shot glass rim around the entirety of the perimeter thereof, thus forming a seal. A connecting element 52 extends from the underside of the top wall displaceable portion to the film 50, thus anchoring the shot glass 30 such that the rim 32 thereof is maintained in abutting relation with the partition 40. As can be seen in Figure 2A, the rim 32 of the shot glass 30 is arranged radially outward of the hole 42 and it is via the hole 42 that the connecting element 52 and film 50 interconnect.

When the container 1' is opened, in the manner previously described, the displaceable top wall portion 26 draws the connecting element 52 upwardly, which element in turn pulls on the film 50 (as the shot glass 30 is drawn into tighter abutment with the partition 40) with

- 16 -

sufficient force to overcome the bond between the film 50 and shot glass 30, whereby the film 50 is detached from the shot glass 30, and drawn through the hole 42 by the connecting element 52 (to which it remains attached), and the shot glass 30, now no longer supported, descends in the can 20 such that the two liquids mix, the descent and mixing
5 being observable through the window 22.

In a variant of this embodiment, the film 50 is additionally attached to the underside of the partition 40, whereby it is the film 50, rather than the connecting element 52, which defines the anchor holding the shot glass 30 to the partition 40, so that the connecting
10 element 52 serves to break not only the bond between the film 50 and shot glass 30 but also the interconnection between the film 50 and partition 40. Also, the partition 40 can, without departure from the invention, be replaced with an alternative internal member (not shown), supported from the vessel 20, which does not (while the shot glass 30 is anchored) separate the can interior into two mutually isolated zones. The member may, for example,
15 comprise arms, which extend radially inwardly from circumferentially spaced positions on the vessel sidewall, and a ring section, the opening through which is perpendicular to the upright axis of the vessel, to which radially inner ends of those arms connect and to which the film and rim are attached so as to be in the same position relative to the opening as they are in the arrangement shown in Figure 2A.

20

A container 1" according to a third preferred embodiment of the present invention is illustrated in Figures 3A and 3B. The container 1" is similar to that of the variant of the second embodiment, described above, in which the sealing film 50 anchors the shot glass 30 to the underside of the partition 40, differing only with respect to the whereabouts
25 of the partition hole 42 and shot glass 30 and the mechanism for effecting simultaneous opening of the container and release of the shot glass 30. Specifically, in the container 1", the hole 42 is centrally disposed in the partition 40, so that the shot glass 30 is centrally disposed against the partition underside, and a connecting element 52, comprising a cable or cord, is attached at a lower end thereof to the film 50, passes through a hole 29 formed
30 in the can top wall 26 and is connected at an upper end thereof to the lever 24 of a ring-pull mechanism of the can, of the type previously described. The interconnection between the

- 17 -

film 50 and underside of the partition 40 is such that a circumferential seal is formed around the hole 42, whereby the zone defined upward of the partition 40 ("upper zone") is fluidly isolated from the zone defined downward of the partition 40 ("lower zone"), so that no liquid can escape from the lower zone into the upper zone, the latter not being fluidly
5 isolated from the atmosphere given the hole 29. When the lever 24 is operated, it pulls on the cord 52, which in turn pulls on the film 50, detaching the film 50 from the shot glass rim 32 and breaking the interconnection between the film 50 and the underside of the partition 40, such that the shot glass 30 is no longer supported and descends in the can 20 whereby the two liquids mix, the descent and mixing being viewable through the viewing
10 window.

A container 1" according to a fourth embodiment of the present invention is shown in Figures 4A and 4B. In this embodiment, the vessel 20 comprises a glass or plastic bottle, instead of a can, and the closure comprises a lid 35, which may, for example, take the form
15 of a screw-top lid or a crown cap. The rim 32 of the shot glass 30 is arranged within a neck portion of the bottle 20. A film 50, of the type previously described, is applied over the mouth and attached to the shot glass rim 32, thereby sealing the mouth of the shot glass 30. An anchor, which in this embodiment is defined by a pair of connecting elements 52, interconnects the shot glass 30/film 50 and lid 35, each element 52 being
20 attached, at an upper end thereof, to the lid 35, and attached at a lower end thereof to the film 50 at a position diametrically opposite to that at which the lower end of the other connecting element is attached. Because in this embodiment the bottle 20 is transparent, no viewing window is required. Release of the lid 35 and upward displacement thereof causes the connecting elements 52 to draw the shot glass rim 32 against the narrowing
25 neck of the bottle 20 until the tension thus applied to the connecting elements 52 is sufficient to detach the film 50 from the shot glass 30, whereby the shot glass 30 descends in the bottle liquid and the two liquids mix. The side wall and base of the bottle may have been separately formed, to permit, before the side wall and base are connected together, an assembly comprising the shot glass 30, film 50 and connecting elements 52 to be
30 introduced into the bottle interior through the bottom, fusion of the upper ends of the connecting elements to the underside of the lid 35, application of the lid 35 to the mouth of

- 18 -

the bottle and filling of the bottle interior, from the bottom, with the drink constituent 21.

A container 1''' according to a fifth embodiment of the present invention is shown in Figures 5A and 5B. In this embodiment, the vessel 20 comprises a glass or jar, which may be formed from glass or plastic, and the closure comprises a lid 35, which may, for example, take the form of a screw-top lid configured with a thread which engages a corresponding thread formed at a top end of the glass/jar 20. An induction seal or interior sealant material lining, as previously described, is applied to the underside of the lid top wall 23, the rim 32 of the shot glass 30 being received sealingly against the seal/lining, which thus anchors the shot glass to the top wall 23. In this embodiment, again, the seal, alternatively or additionally, may be defined by a patch of sealant applied to the top wall underside and/or a bead of sealant applied around the shot glass rim. A pusher 60 projects from an internal face of the vessel side wall such that a distal end thereof abuts the shot glass 30, which is arranged slightly eccentric to the axis of rotation of the lid 35, with the result that when the lid 35 is unscrewed, the pusher 60 precludes the shot glass 30 from rotating with the lid 35 and thus causes the shot glass 30 to detach from the lid underside, whereby the shot glass 30 is no longer supported and descends in the glass/jar 20 such that the two liquids 21 and 31 mix, the descent and mixing being viewable through the transparent side wall of the vessel 20.

20

A container 100 according to a sixth embodiment of the present invention is shown in Figures 6A to 15. Referring to Figure 6B, the vessel comprises a glass or bottle 120, which may be formed from glass or plastic, and the closure comprises a lid 135 which consists of two components, namely an outer lid component in the form of a cap 136, and an inner lid component 138 which is secured to the upper end of the vessel 120. The container 100 also includes a shot holder or receptacle, in the form of a shot glass 130, which depends from the component 138. The component 138 comprises a collar portion 138A which is received over a top end of the vessel 120, and diametrically opposed tabs 138B projecting downwardly from the collar portion 138A so as to be received in complementarily configured recesses 120A formed into the vessel sidewall 120A. The second component 138 includes diametrically opposed lugs 138C which project radially

30

- 19 -

outwardly from the collar portion 138A. The second component 138 further comprises a roof 138D, as can be seen in Figures 6D, 6E and 7, which is configured with a circular hole 139 therethrough, the centre of which hole is offset from the centre of the circular roof 138D.

5

A sheet of film 150 is secured, at a lower side thereof, to the rim of the shot glass and, at an upper side thereof, to the underside of the roof 138D such that it extends across the hole 139, whereby the shot glass 130 is supported from the second component 138 via the film 139, which seals the opening into the shot glass 130 and thus precludes escape of the
10 shot glass contents.

The interior details of the cap 136 can be seen in Figure 6C and Figures 8B and 8C. The cap 136 comprises a collar portion 136A and diametrically opposed tabs 136B, which project downwardly from the collar portion 136A. The interior wall of the collar
15 portion 136A is configured with diametrically opposed circumferential channels 136C, each of which extends through an angle of about 90 degrees (into each of which a respective one of the lugs 138C is received, as will be described in further detail later), and diametrically opposed axial channels 136D into each of which a respective circumferential channel 136C opens at a trailing end thereof.

20

The lid outer component 136 further comprises a closed roof 136E and, projecting downwardly from that roof, a pair of circular blades, consisting of a radially inner blade 137A and a radially outer blade 137B. The pair of blades is configured such that the cutting edge of blade 137A is positioned at a level lower than the cutting edge of
25 blade 137B. In the illustrated embodiment, the cutting edge of blade 137A is straight and the cutting edge of blade 137B is toothed or jagged. However, the cutting edge configurations can vary without departure from the invention; for example, the cutting edge of blade 137A could be jagged and the cutting edge of blade 137B straight, both cutting edges may be straight, or both cutting edges may be jagged. Blade 137A, unlike
30 blade 137B, does not form a complete circle, there being a gap defined between opposite ends thereof. The blades operate to cut the film 150, to effect release of the shot glass 130

- 20 -

into the liquid in the vessel 120 and escape of the shot glass 130 contents into the liquid, as will be described in further detail later. The common centre of the two circles defined by the blades 137A and 137B is offset from the centre of the circular roof 136E, in the same way that the centre of the hole 139 is offset from the centre of the roof 138D.

5

The container 100 in its starting configuration is illustrated in Figures 6A and 8A to 8C. In this configuration, the cap 136 is arranged atop the vessel 120 and second lid component 138, which component is secured to the upper end of the vessel 120. In this configuration, the lugs 138C are arranged in the circumferential channels 136C of the cap 136, at the leading ends of those channels, whereby the cap 136 is axially locked to the component 138 and vessel 120, such that downward or upward displacement of the cap 136 is precluded. The component 136 is, however, rotatable in a manner causing the channels 136C to be drawn over and along the respective lugs 138C, through an angle of about 90 degrees, to the position shown in Figures 9, 10A to 10C, 11 and 12A, i.e. until the lugs 138C are received into the axial channels 136D, whereupon they abut sidewalls of the axial channels 136D to preclude continued rotation of the cap 136. At the completion of the rotation, the centre of the circles defined by blades 137A and 137B is positioned directly above the centre of the hole 139, as shown in Figure 10B, such that the blades become receivable into that hole. Blade 137B overlies a region which is radially outward of the rim of the shot glass but radially inward of the perimeter of the hole 139 whereas blade 137A overlies a region radially inward of the shot glass rim. Referring to Figures 11 and 12A to 12C, application of a downward force, particularly by way of a sharp strike (e.g. with a the palm of the hand or a closed fist), to the cap 136 results in downward displacement of the cap 136, during which the channels 136D ride over and along the lugs 138C, whereby the blades 137A and 137B are driven into the film 150 (see also Figures 13A to 13C). More particularly, blade 137A, owing to its cutting edge being lower than the cutting edge of blade 137B engages the film 150 first and effects a substantially circular incision therein, and the blade 137B thereafter engages the film 150 so as to effect a circular incision therein, thereby causing a circular portion of the film to be released from the remainder of the film such that the shot glass 130 drops from the roof 138D. The radially inner cut created in the film by the blade 137A creates an opening, through the

10

15

20

25

30

- 21 -

film 150, into the shot glass 130, such that the shot glass contents are released into the liquid in the vessel 120 as the shot glass 130 descends. Because the cut formed by the blade 137A is not continuous all the way therearound (owing to the gap defined between the aforementioned ends of the blade 137A), the substantially circular portion of the film 150 created by the blade 137A is tethered to the rim of the shot glass 130. Therefore, both parts of the film 150 created by the cutting thereof (i.e. the radially outer annular part remaining bonded to the underside of the roof 138D and the circular portion, created by blade 137A, remaining tethered to the shot glass rim) remain anchored to components of the container 100 and thus cannot be inadvertently swallowed by a person drinking the beverage thus created.

Referring to Figures 14A, 14B and 15, while the cap 136 remains in the same, rotationally displaced, orientation, the lid component 136 can be drawn upwardly and, owing to the channels 136D opening through the lower ends of the collar portion 136A, removed from the remainder of the container 100, whereby the beverage created by mixing of the liquid and vessel 120 and shot glass contents can pass through the hole 139 so as to be consumed. A person can consume the beverage either by placing his or her lips against an edge of the component 138 adjacent the hole 139 and pouring the beverage into his or her mouth, as is facilitated by the hole 139 being eccentric whereby part of the perimeter thereof is closely adjacent a section of the perimeter of the component 138, or via a straw inserted through the hole 139 and into the beverage. Alternatively, the component 138 may be removable whereby the person can drink from the vessel 120 directly.

A container 100' according to a seventh embodiment of the present invention is shown in Figure 19. Referring to Figures 16A and 16B, the vessel 120' of the container 100' comprises a glass or bottle 120', which may be formed from glass or plastic, and the closure of the container 100' comprises a lid 135' which consists of three components, namely an outer lid component 136' (shown on its own at Figure 17A), an inner lid component 138' (shown on its own at Figure 17B) which is secured to the upper end of the vessel and a lid component 140', as can best be seen in Figures 16A and 18B, which is configured with an internal circumferential thread engaged with a corresponding external

- 22 -

circumferential thread formed at the upper end of the shot holder or shot glass 130', whereby the shot holder, which again takes the form of a shot glass 130', is secured to the lid 140', the interengaging threads forming a seal which precludes liquid in the shot holder 130' from escaping between the shot holder 130' and lid component 140'. The lid component 140' is configured with an upwardly opening recess or cavity 141' which has a hexagonal transverse cross-sectional configuration.

Referring to Figure 17B, the component 138', like the component 138 in the previous embodiment, comprises a collar portion 138A' which is received over a top end of the vessel 120,' and diametrically opposed tabs 138B' projecting downwardly from the collar portion 138' so as to be received in complementarily configured recesses 120A' formed into the vessel side wall. The component 138A' comprises diametrically opposed lugs 138C' which project radially outwardly from the collar portion 138A' in exactly the same way as the lugs 138C project from the collar portion 138A in the previous embodiment. The component 138' further comprises a rotational locking portion 138E' which is integrally formed with the collar portion 138A' and comprises arms 138F' spaced at equal intervals around the circumference of the collar portion 138', each of which arms extends downwardly and radially inwardly from the collar portion 138A', and a ring portion 138G' to which lower/radially inner ends of the arms 138F' connect, the ring portion 138G' being configured with a hexagonal opening 138H' therethrough. As can best be seen in Figure 17B, respective openings are defined between adjacent ones of the arms 138F', which openings permit passage of liquid, from the interior of the vessel 120' when the container 100' is opened, out of the vessel 120', whereby a consumer can drink from the open vessel 120', and/or permit filling of the vessel 120', with the liquid it is to hold, to a level above the ring portion 138G'.

Referring to Figure 17A, the lid outer component 136' comprises a collar portion 136A' and diametrically opposed tabs 136B', which project downwardly from the collar portion 136A'. The interior wall of the collar portion 136A' is configured with diametrically opposed circumferential channels 136C', each of which extends though an angle of about 90 degrees and into each of which a respective one of the lugs is received,

- 23 -

and diametrically opposed axial channels 136D' into each of which a circumferential channel 136C' opens at a trailing end thereof, the channels 136C' and 136D' having a configuration identical to that of the channels 136C and 136D in the container 100. The component 136' further comprises a closed roof 136E' and, projecting downwardly from that roof, a collar portion 136F' and a hexagonal key portion 136G' concentrically arranged
5 inside the collar portion 136F'.

Details of the container 100' in its starting configuration (which configuration is shown in Figure 19) are shown at Figures 18A and 18B, from each of which a view of the
10 vessel 120' (to the upper end of which the component 138' is secured) is omitted and from the latter of which a view of the component 138' is omitted, for the purposes of clarity. As can best be seen in Figure 18B, in that configuration, the shot holder lid 140' is received in the collar portion 136F' such that the hexagonal key 136G' is received in the hexagonal lid cavity 141', forming a substantially size-for-size fit therewith. As can also be seen in
15 Figure 18B, a circumferential side wall of the lid 140' is configured with a radially outwardly opening circumferential groove 141A' and the collar portion 136F' with a circumferential rib 136H' projecting radially inwardly from the interior face of the collar side wall such that it is received in the groove 141A'. The interengagement between the rib 136H' and groove 141A' precludes the lid 140' from escaping through the open lower
20 end of the collar portion 136F'. Also in this configuration, the body of the shot holder 130' passes through the hexagonal opening 138H', whereby the sidewall of the shot holder body, which has a transverse cross-sectional configuration that is hexagonal so as to complement the perimeter of the hexagonal opening 138H', lies closely adjacent the ring portion 138G'. In this configuration, the cap 136' is arranged atop the vessel 120' and lid
25 component 138A', which component is secured to the upper end of the vessel 120' (the tabs of that component being received in the recesses in the vessel side wall such that that component forms a rotational interlock with the vessel). In this configuration, the lugs are arranged in the circumferential channels 136C', of the cap 136', at the leading ends of those channels, whereby the cap 136' is axially locked to the component 138' and vessel 120',
30 such that downward or upward displacement of the cap 136' is precluded. The component 136' in the starting configuration, although axially locked, is rotatable in a

- 24 -

manner causing the channels 136C' to be drawn over and along the respective lugs, through an angle of about 90 degrees, until the lugs are received into the axial channels 136D', whereupon they abut sidewalls of the axial channels 136D' to preclude continued rotation of the cap 136'. During the rotation of the cap 136', the key 136G, owing to its being rotationally interlocked with the lid 140', turns that lid, while rotation of the shot holder body is precluded by the rotational interlock formed between that body and the ring portion 138G'. At the completion of the rotation, the lid 140' has been fully unscrewed from the shot holder, and the latter remains suspended owing only to a contact engagement between the shot holder side wall and the ring portion 138G'. Application of a downward force, particularly by way of a sharp strike, to the cap 136' results in a downward displacement of the cap 136', during which the channels 136D' ride over and along the lugs, whereby the shot holder is displaced downwardly (by a force which overcomes the engagement between the shot holder side wall and the ring portion 138G') whereby the thus-opened shot holder descends into the liquid in the outer container, and its contents thus are released into the liquid in the vessel so as to mix therewith. The shot holder body may narrow at a position just above the portion thereof which contacts ring portion 138G' once the lid 140' has been unscrewed from the shot holder and before the application of the downward force, whereby, upon said portion being squeezed through the hexagonal opening 138H', as a result of the force, the shot holder ceases to be in contact with the ring portion 138G' and descends in the liquid in the vessel 120'.

In each of the containers 100 and 100', the circumferential channels and lugs, when the latter are axially trapped by the former, define a tongue-and-groove interconnection which can be released, broken or deactivated by rotation of the closure/closure member 136/136' relative to the vessel 120/120'

A beverage container 200 according to an eighth embodiment of the present invention is shown in transverse cross-section at Figure 23A, and is identical in external shape and configuration to container 100' as shown in Figure 19. The vessel 220 of the container 200 comprises a glass or bottle, which may be formed from glass or plastic, and the closure comprises a lid 235 which comprises a cap 236 an upright circumferential side wall 236 of

- 25 -

which is configured with an internal thread 236A that is engaged with a corresponding external thread 220B formed at an upper end of the vessel sidewall 220A, whereby the lid 235 is secured to the vessel 220. The lid 235 further comprises a roof 236E and, projecting downwardly from that roof, a cylindrical collar 236F which is concentric with the side wall 236. The collar 236F is configured with an internal thread 236G which engages a corresponding external thread 231 formed at an upper end of the shot holder 230 (which, again, preferably takes the form of a shot glass), whereby the receptacle 230 is supported by, and depends from, the lid 235, and more particularly from the cap 236. Referring to Figure 21C, the body 230A of the receptacle 230 has a hexagonal cross-sectional exterior configuration. Referring to Figures 20A, 20B and 21B, the container 200 further includes a locking element 240 which is configured with a central opening 241 that is complementary in configuration to the aforementioned cross-sectional configuration of the shot container 230, i.e. hexagonal in the present embodiment, such that the body of the shot receptacle is received through the opening 241 and either lightly contacts the element 240 or is closely adjacent though clear of the element 240. The element 240 further comprises radially outwardly projecting arms or tabs 242 which are angularly spaced apart at regular intervals around the element 240, distal ends or tips of the tabs 242 lying closely adjacent the interior face of the sidewall 220A. Referring to Figures 20A, 20B and 21A, integrally formed with the side wall 220A is a circumferential shoulder or shelf 260 on which the distal ends/tips of the tabs 242 sit such that the element 240 is supported by the shoulder or shelf 260 in the vessel 220, and precluded from dropping to the bottom of the vessel 220. As can best be seen at Figure 21A, the shoulder/shelf 260 comprises flat sections 261 which are distributed around the shoulder circumference at equal angular intervals and on which the tips of respective ones of the tabs 242 rest, as shown in Figures 20A and 20B, and ramp sections 263 each of which extends between respective adjacent ones of the flat sections 261 and comprises a sloped upper face 264 and a substantially upright face 265 at an end thereof. The shoulder or shelf 260 thus permits rotation of the element 240 in a clockwise direction, during which rotation the tabs 242 simultaneously ride up and over respective ones of the sloped ramp faces 264 and thence drop onto the succeeding flat sections 261, but is precluded from rotation in the opposite (anti-clockwise) direction upon and by abutment between the

- 26 -

upright faces 265 and radially extending edges of respective ones of the tabs 242. Referring to Figures 21B and 23A, the element 240 includes stabilisers 245 each of which projects downwardly from the lower face of a respective one of the tabs 242 radially inward of the distal end/tip of that tab, such that a radially outer face thereof lies closely adjacent a side face 265 of the shoulder/shelf 260. Each stabiliser 245 can thus slide against the radially inner side of the shoulder/shelf 260 during rotation of the locking element 240 on the shoulder/shelf 260.

Assembly of the container 200 is carried out as follows. The vessel 220 is filled to the appropriate level with liquid and the locking element 240 is located on the shoulder 260, as shown in Figure 20B. Separately, the shot glass/holder 230 is filled with the liquid shot and its threaded upper end screwed into the threaded collar 236F, the interengaging threads 236G, 231 of the shot holder 230 and collar 236F forming a seal which precludes liquid in the shot holder 230 from escaping between the shot holder 230 and collar 236F. The assembly consisting of the thus-interengaged cap 236 and shot holder 230 is lowered such that the body 230A of the shot holder 230 is received through the hexagonal opening 241 in the locking element 240 and the internal thread 236A thread in the lid 235 is brought into engagement with the vessel's thread 220B and the lid 235 thence screwed downwardly onto the vessel 220 such that a seal is formed between the vessel 220 and cap 236, precluding escape of the liquid in the vessel 220 between the vessel 220 and cap 236. During the downward screwing of the cap 236 onto the vessel 220, the shot holder 230, which rotates with the lid 235/cap 236, turns the locking element 240 clockwise, owing to its rotational interlock therewith, such that the latter rides over the shoulder/shelf 260 in the manner previously described. Upon the lid 235/cap 236 being fully screwed onto the vessel 220, assembly of the container 200 is complete.

It will be clear that the locking member 240 and the shoulder/shelf 260 with which that member is engaged define a ratchet mechanism or rotational clutch mechanism permitting the shot receptacle 230 and closure member/cap 236 to rotate together in the rotational direction in which the closure member/cap 236 is secured/screwed to the vessel 220 but precluding rotation of the shot receptacle 230 in the rotation direction in which the closure

- 27 -

member/cap 236 is removed/decoupled/unscrewed from the vessel 220 and thus precluding the shot receptacle 230 and closure member/cap 236 from rotating together in the latter rotational direction.

5 To open the container 200 and effect release of the shot receptacle 230 into the liquid in the vessel 220, a person simply rotates the lid 235/cap 236 anti-clockwise, thereby unscrewing it from both the vessel 220 and the shot receptacle 230, the latter being precluded from rotating with the lid 235/cap 236 by abutment between the end faces 265 and the radial edges of respective ones of the tabs 242, as previously mentioned, and the
10 rotational interlock between the shot receptacle body 230A and the locking element 240. Referring to Figure 23B, upon the threads 236G, 231 of the shot holder 230 and collar 236F disengaging, the latter drops through the hole 242 and descends in the liquid in the vessel 220, such that its contents are released into that liquid. The locking element 240 can then be removed from the vessel 220, or instead allowed to remain in the vessel, and
15 the thus mixed beverage drunk directly from the vessel 220. As can best be seen in Figure 21B, respective openings are defined between adjacent ones of the tabs 242, which openings can permit passage of liquid, from the interior of the vessel 220 when the container 200 is opened, out of the vessel 220, whereby a consumer can drink from the open vessel 220, and/or permit filling of the vessel 220, with the liquid it is to hold, to a
20 level above the locking element 240 if already in position when such filling is carried out.

Without departure from the invention, the locking element 240 may be tethered to the lid 235 e.g. via a flexible line which is preferably slack when the container 200 is closed, such as a string, whereby separation of the lid 235 and vessel 220 causes the lid 235 to pull
25 the locking element 240 out of the vessel 220.

The locking element 240 may, conveniently, bear graphics and/or other markings which can define an advertisement or which can differ from those borne by the locking elements 240 of other containers 200 produced earlier or later in time, the thus-differing
30 locking elements being collectibles. Alternatively or additionally, the locking element 240, when removed from the opened vessel 220, can define a coaster upon which

- 28 -

the opened vessel 220 can rest.

In the drawings of the containers 100' and 200, the vessel 120'/220 and shot receptacle 130'/230 appear opaque only for the purposes of clearly communicating their configurations. In the most preferred form of each of those containers, at least the side walls, and preferably the entireties, of the vessel and shot holder will be transparent or otherwise able to be sufficiently seen through, whereby mixing of the contents of the vessel and shot holder can be clearly seen, through the vessel side wall, enhancing the experience of the beverage consumer.

5
10

The structural components of either or each of the containers 100' and 200 can be disposable or reusable.

While various embodiments of the present invention have been described above, it should be understood that they have been presented by way of example only, and not by way of limitation. It will be apparent to a person skilled in the relevant art that various changes in form and detail can be made therein without departing from the spirit and scope of the invention. Thus, the present invention should not be limited by any of the above described exemplary embodiments.

15
20

Throughout this specification and the claims which follow, unless the context requires otherwise, the word "comprise", and variations such as "comprises" and "comprising", will be understood to imply the inclusion of a stated integer or step or group of integers or steps but not the exclusion of any other integer or step or group of integers or steps.

25

The claims defining the invention are as follows:

1. A beverage container comprising:
a drinking vessel containing a consumable liquid; and
5 a receptacle, which is supported over an interior region of the vessel and holds a substance that is to be added to the liquid, in a manner such that the substance is isolated from the liquid,
the container being operable to effect release of the receptacle such that it descends in the liquid and said substance is thus released into the liquid whereby there is produced a
10 beverage drinkable from the vessel.
2. A beverage container according to claim 1, wherein said substance is a liquid.
3. A beverage container according to claim 2, wherein the substance comprises an
15 alcohol-containing liquid.
4. A beverage container according to any one of the preceding claims, wherein the drinking vessel comprises a wall that can be seen through such that the descent of the receptacle in and/or release of the substance into the consumable liquid can be observed.
20
5. A beverage container according to any one of the preceding claims, wherein the vessel is configured in the form of a can, cup, glass, jar or bottle.
6. A beverage container according to any one of the preceding claims, wherein the
25 receptacle comprises or is in the form of a shot glass, or has substantially the same storage capacity as a shot glass.
7. A beverage container according to any one of the preceding claims, wherein the receptacle is sealed and the container is operable to effect unsealing of the receptacle.
30
8. A beverage container according to claim 7, wherein the container includes a seal

- 30 -

over or applied to a mouth of the receptacle.

9. A beverage container according to claim 8, wherein the seal is connected to a closure or closure member of the container and/or to a mechanism for opening the closure
5 or closure member, such that operation of the closure or closure member to open the container breaks, releases or otherwise deactivates the seal.

10. A beverage container according to any one of the preceding claims, including an interconnection between the receptacle and a part of the container and being configured
10 such that the release of the receptacle is effected by breaking, releasing and/or deactivating the interconnection.

11. A beverage container according to claim 10, wherein the interconnection between the receptacle and said part of the container is sealed whereby escape, through the
15 interconnection, of said substance from an interior of the receptacle, or of said liquid from an interior of the vessel, is precluded.

12. A beverage container according to claim 10 or 11, wherein the receptacle depends or hangs from said part of the container via the interconnection.
20

13. A beverage container according to any one of claims 10 to 12, wherein said interconnection comprises a rotatably releasable interconnection.

14. A beverage container according to claim 13, wherein said interconnection
25 comprises a threaded interconnection.

15. A beverage container according to claim 14, wherein said receptacle includes a thread and said part of the container includes a thread engaged with the thread of the receptacle, whereby said threaded interconnection is defined, and wherein one of said
30 receptacle and said part of the container is rotatable relative to the other of said receptacle and said part of the container such that the interconnection is or can be broken, released

- 31 -

and/or deactivated whereby said release of said receptacle is or can be effected.

16. A beverage container according to any one of claims 10 to 15, wherein said part of the container comprises a closure or closure member of the container.

5

17. A beverage container according to claim 16, wherein the container is openable via rotation of the closure or closure member such that the interconnection is or can be broken, released and/or deactivated whereby the release of the receptacle is caused.

10 18. A beverage container according to any one of claims 10 to 17, including a member arranged so as to engage the receptacle, thereby to exert a force on it and thus to break, release and/or deactivate the interconnection.

15 19. A beverage container according to claim 18, wherein said member arranged so as to engage the receptacle extends from a side wall of the vessel so as to exert said force when a closure or closure member of the container or vessel is rotated, otherwise displaced or removed to open, or as part of opening, the container or vessel.

20 20. A beverage container according to claim 18 or 19, wherein said member arranged so as to engage the receptacle forms a part of or is supported from the vessel.

25 21. A beverage container according to claim 17 or any one of claims 18 to 20 as dependent therefrom, wherein the receptacle is interlockingly engaged with the vessel so as to be precluded from rotating during said rotation such that the interconnection is or can be broken or otherwise deactivated via said rotation.

30 22. A beverage container according to claim 21, including a locking member supported from the vessel and engaging the receptacle so as to effect the interlocking engagement between the receptacle and vessel.

23. A beverage container according to claim 22, wherein the locking member

- 32 -

comprises an annular member supported from a side wall of the vessel and surrounding the receptacle.

24. A beverage container according to claim 23, wherein the annular member forms a fit around the receptacle to preclude it from rotating during said rotation.

25. A beverage container according to claim 22 or 23, wherein the locking member sits on a shoulder arrangement or shelf arrangement extending around an interior section of the vessel so as to be interlockingly engaged with the vessel and thus precluded from rotating during said rotation.

26. A beverage container according to claim 22 or 23, wherein the locking member sits on a shoulder arrangement or shelf arrangement extending around a side wall of the vessel inside the vessel so as to be interlockingly engaged with the vessel and thus precluded from rotating during said rotation.

27. A beverage container according to any one of claims 22 to 26, wherein the vessel engages the locking member in a manner such that it resists rotation thereof in the direction of said rotation, whereby the interlocking engagement between the receptacle and the vessel is defined, but does not resist rotation of the locking member in the opposite rotational direction.

28. A method of assembling a beverage container according to any one of claims 22 to 27, wherein an assembly which comprises the receptacle and the closure or closure member and in which the receptacle and the closure or closure member are interconnected is, during securement of that assembly to an assembly which comprises the vessel and the locking member and in which the locking member is supported from the vessel, rotated relative to the vessel, such that the receptacle turns the locking member relative to the vessel.

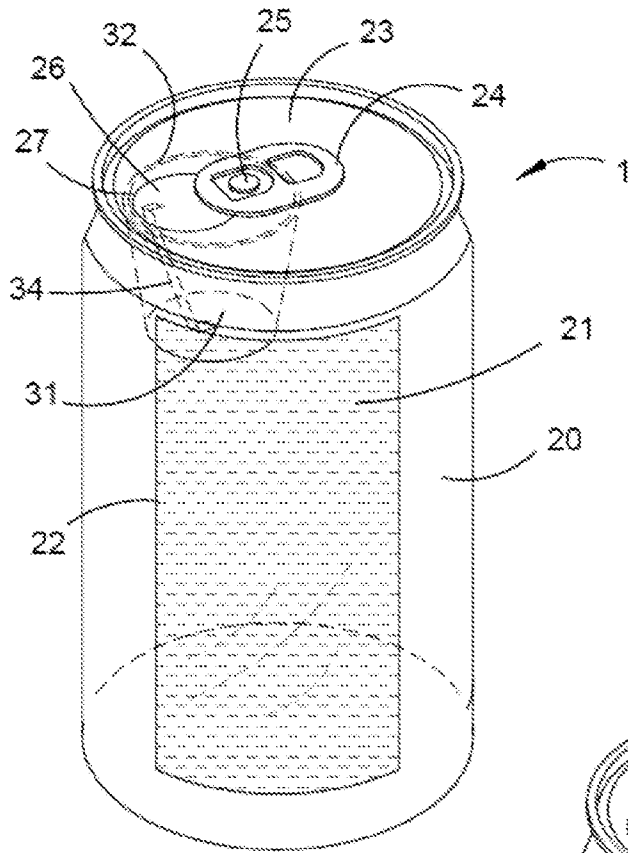

FIGURE 1A

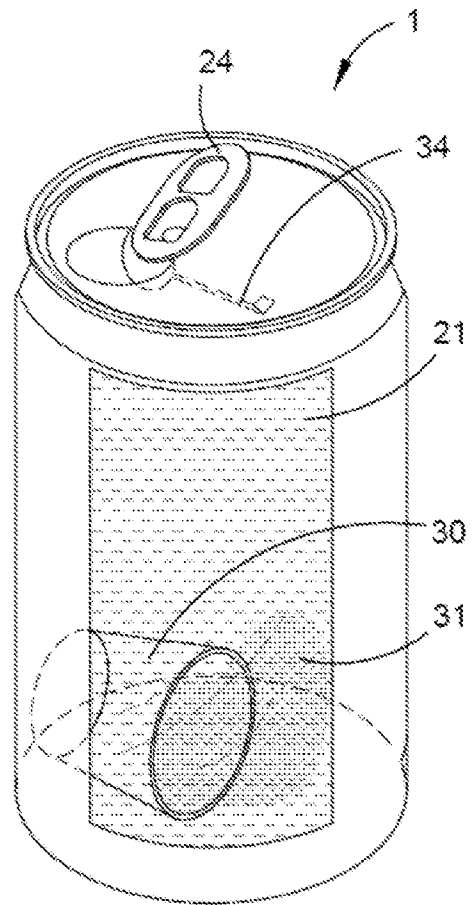

FIGURE 1B

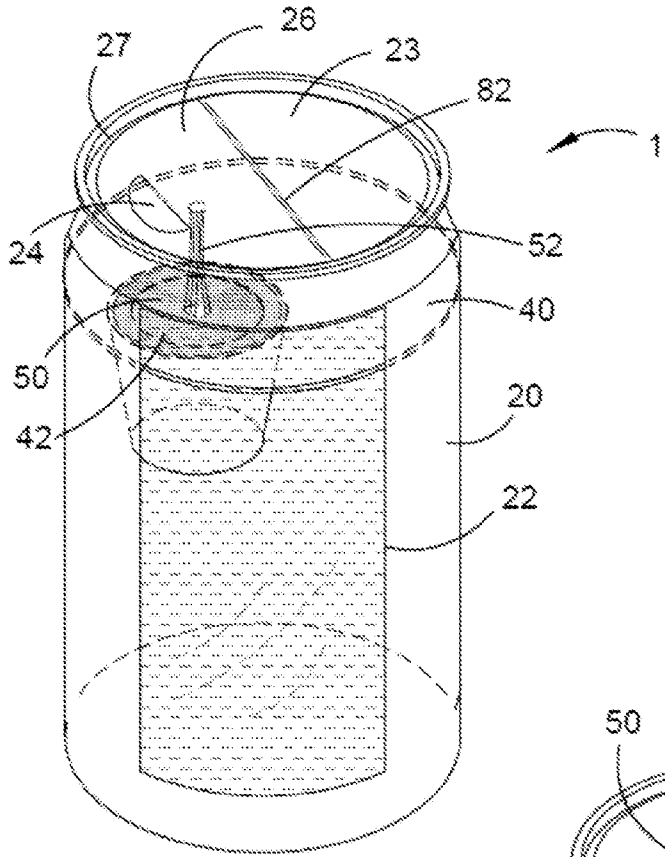

FIGURE 2A

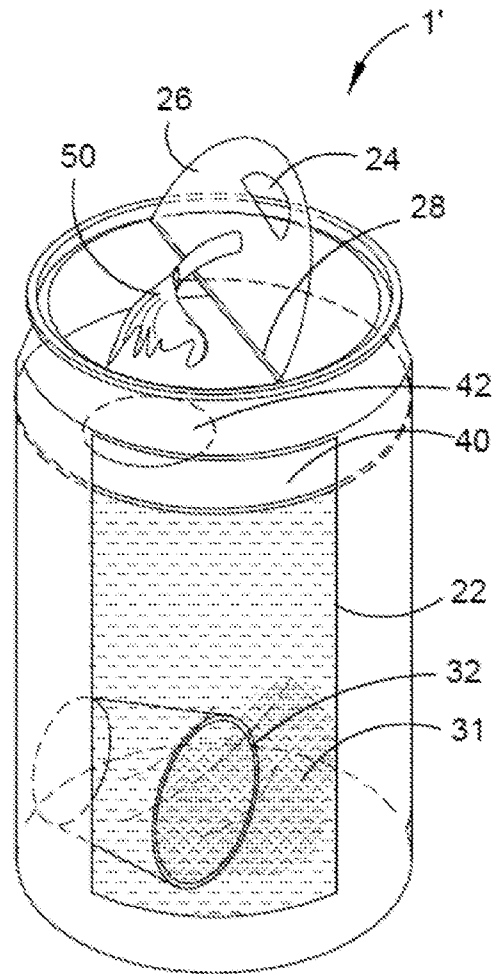

FIGURE 2B

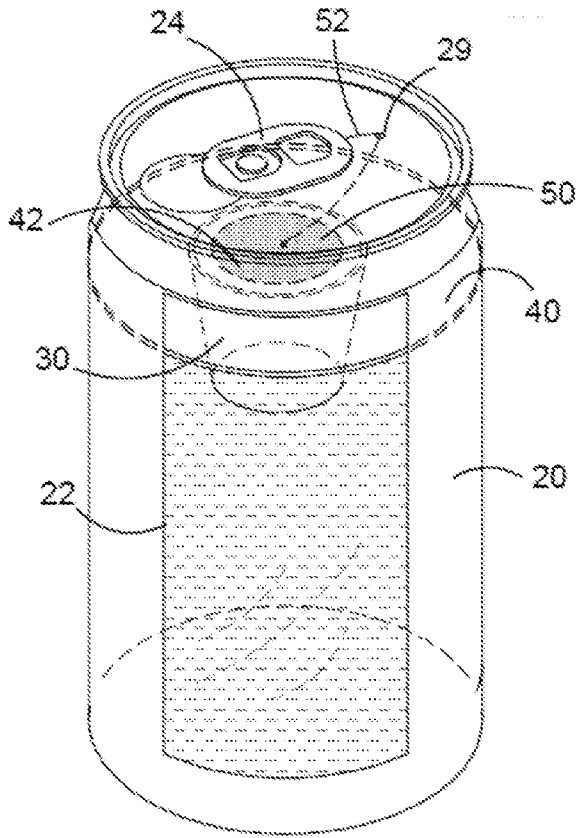

FIGURE 3A

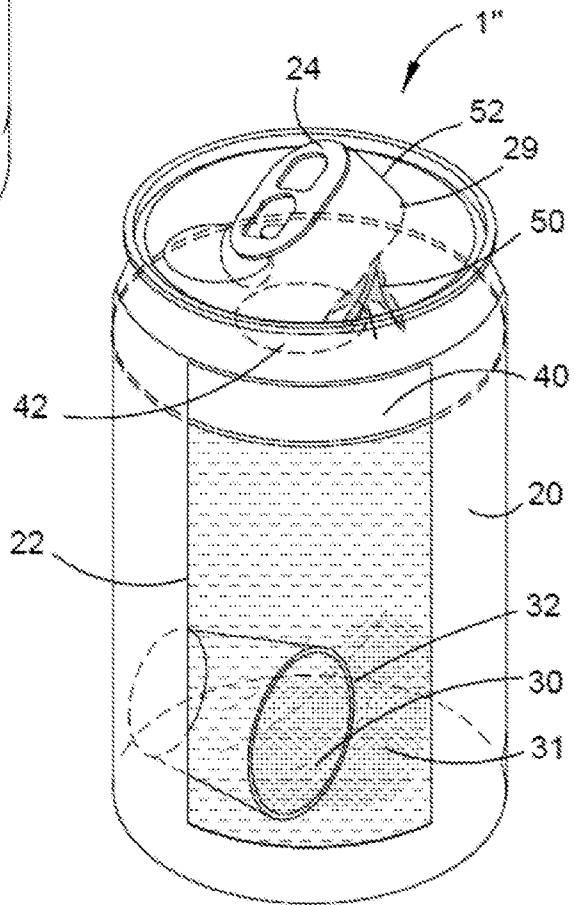

FIGURE 3B

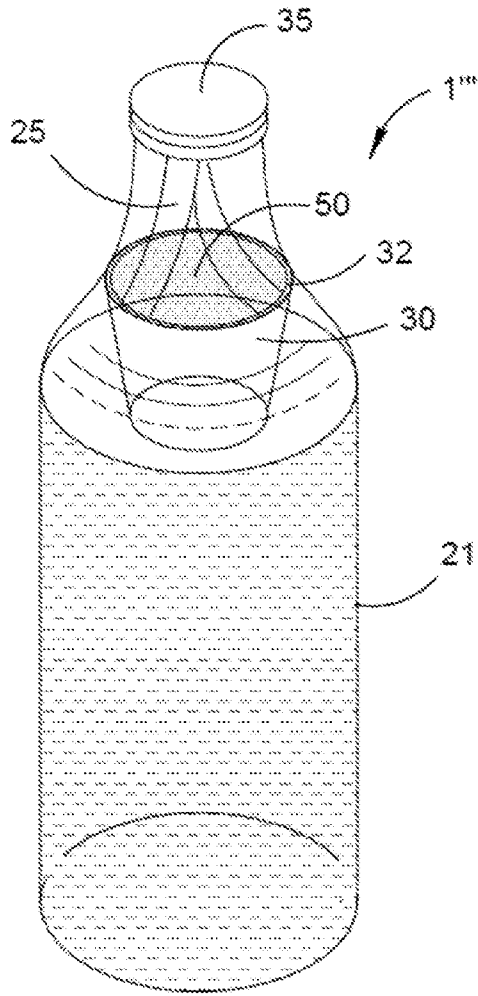

FIGURE 4A

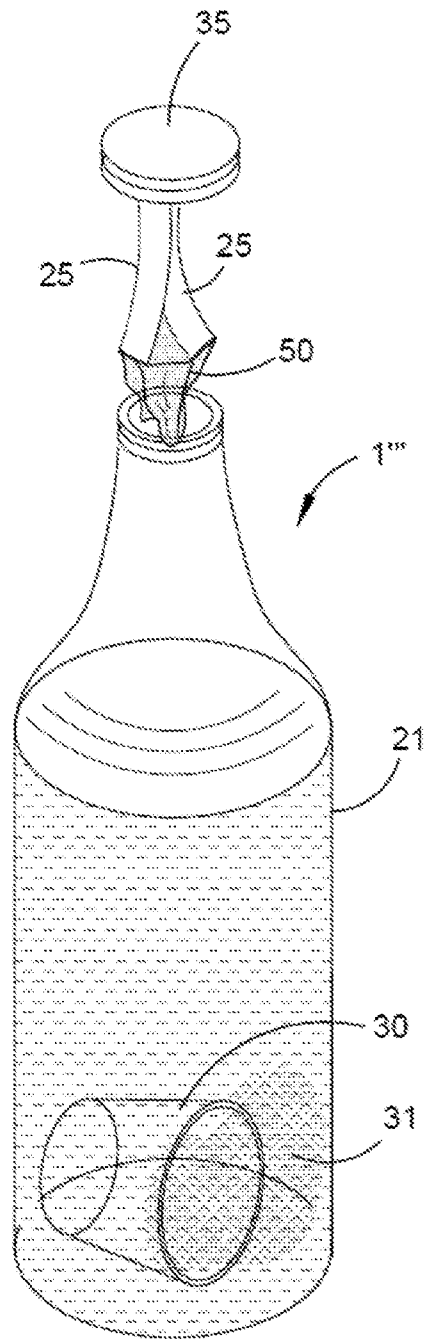

FIGURE 4B

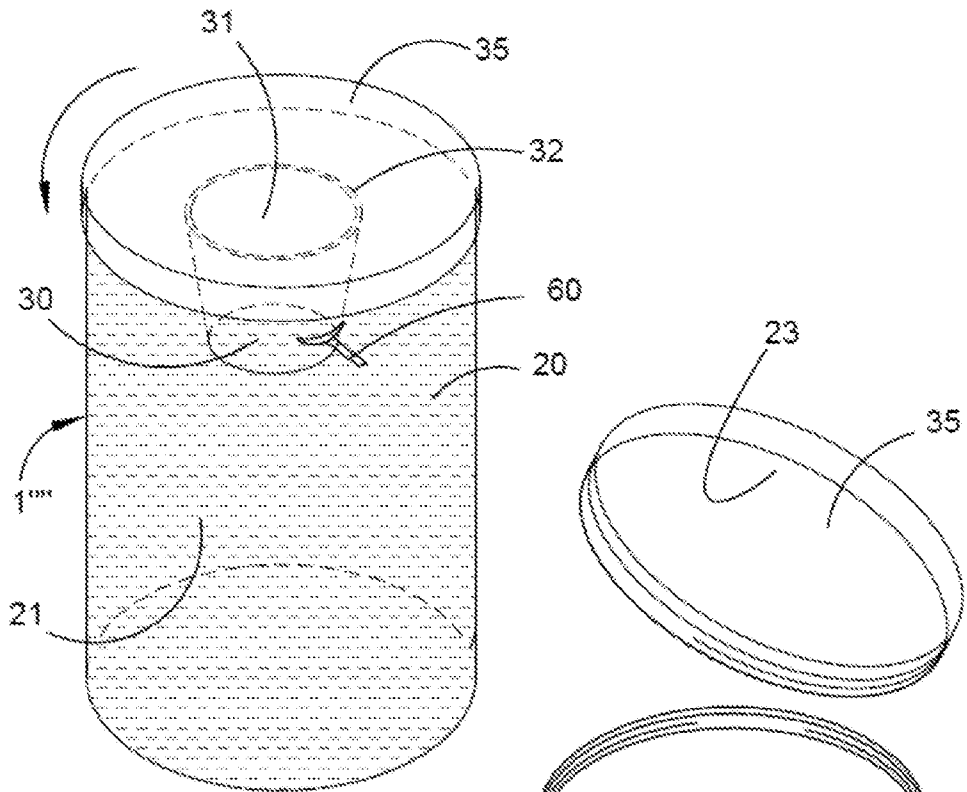

FIGURE 5A

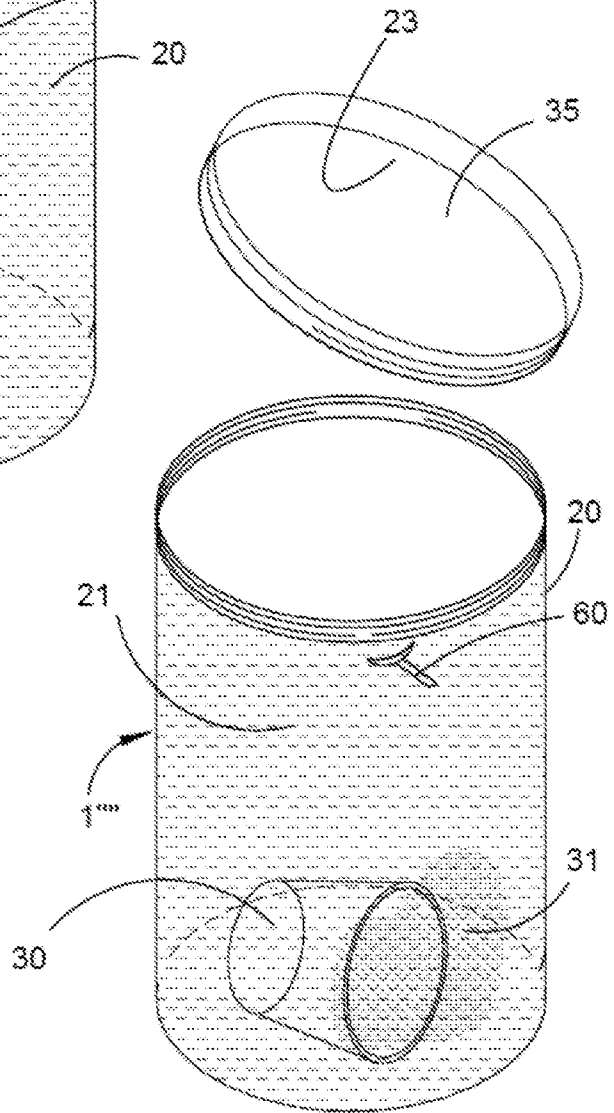

FIGURE 5B

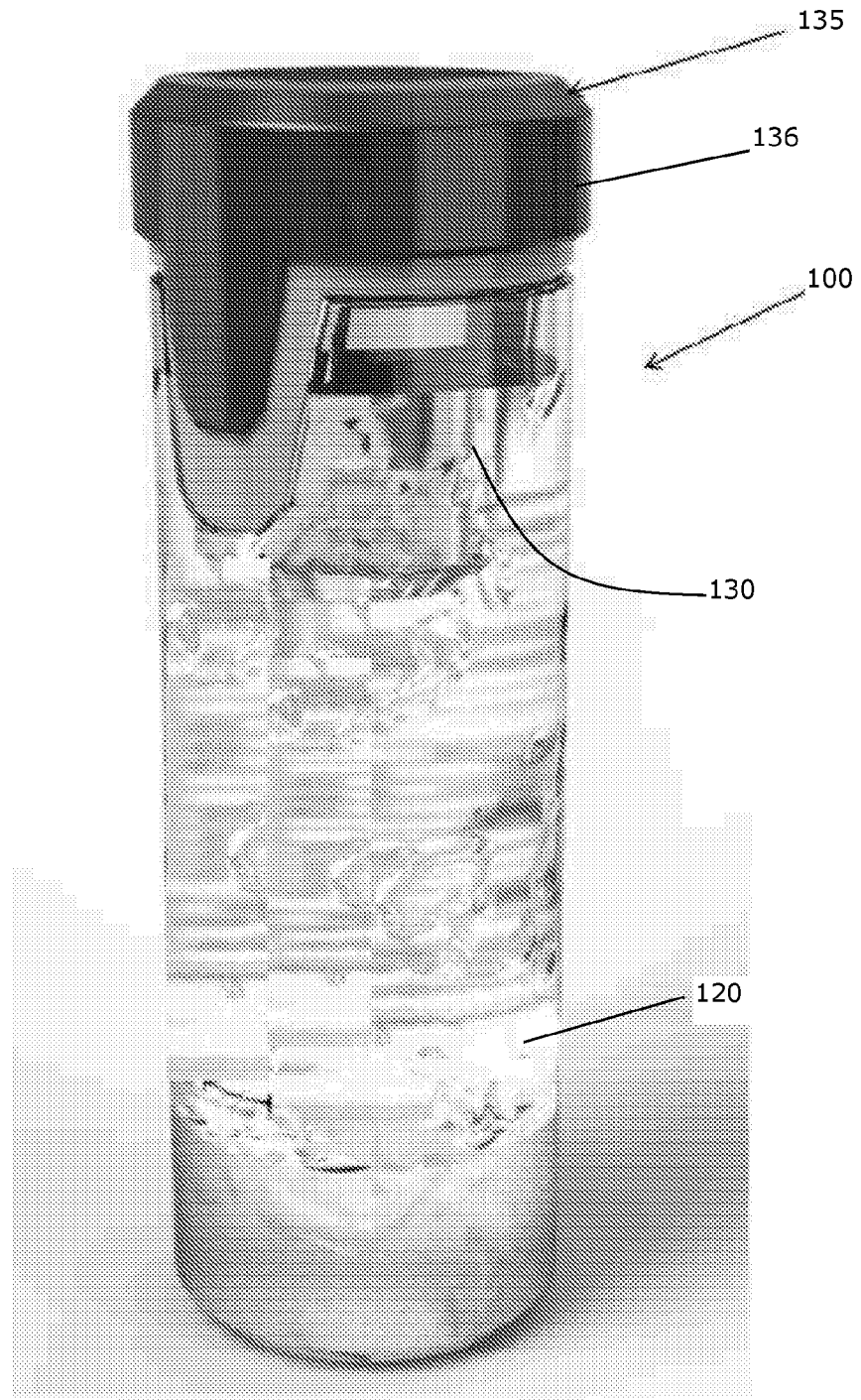

FIGURE 6A

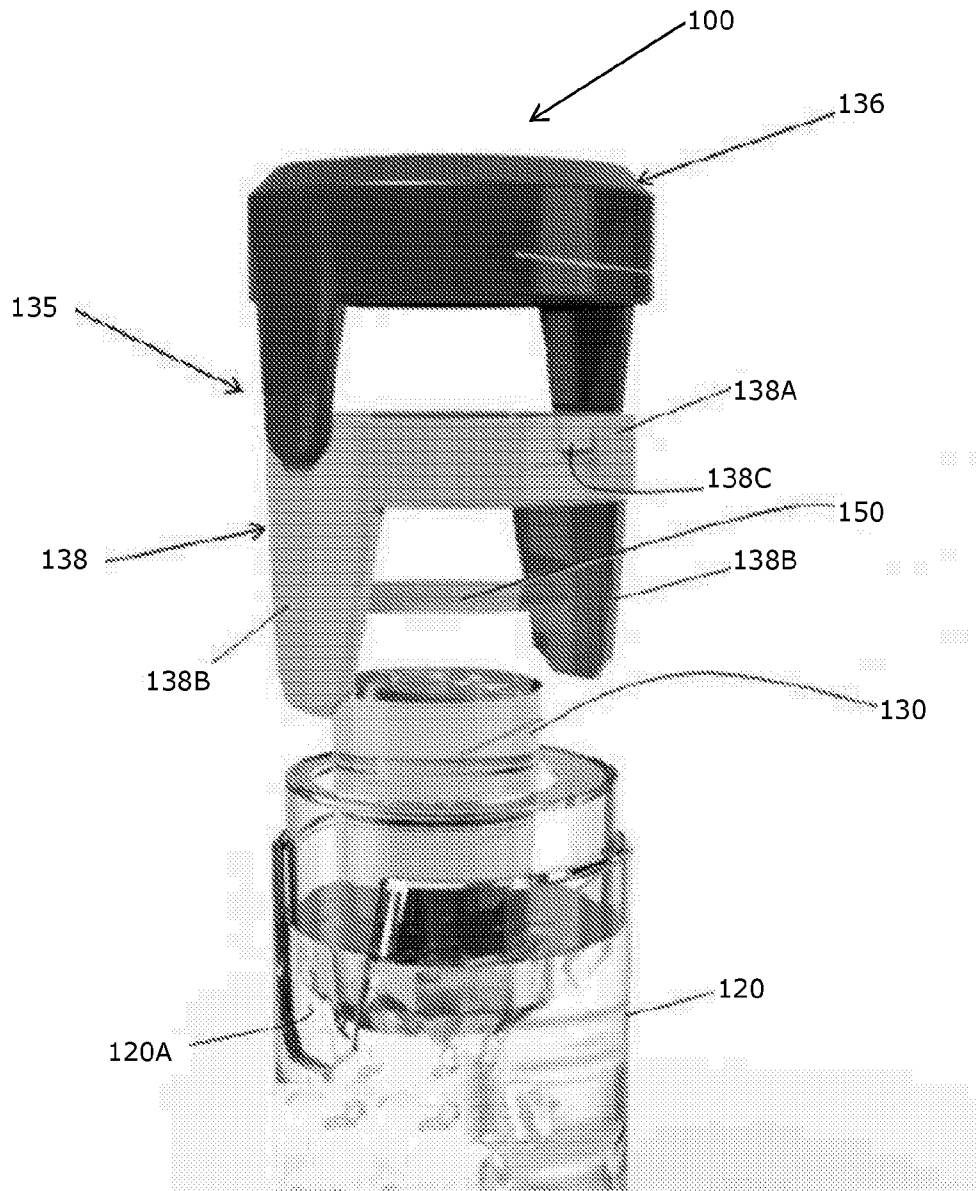

FIGURE 6B

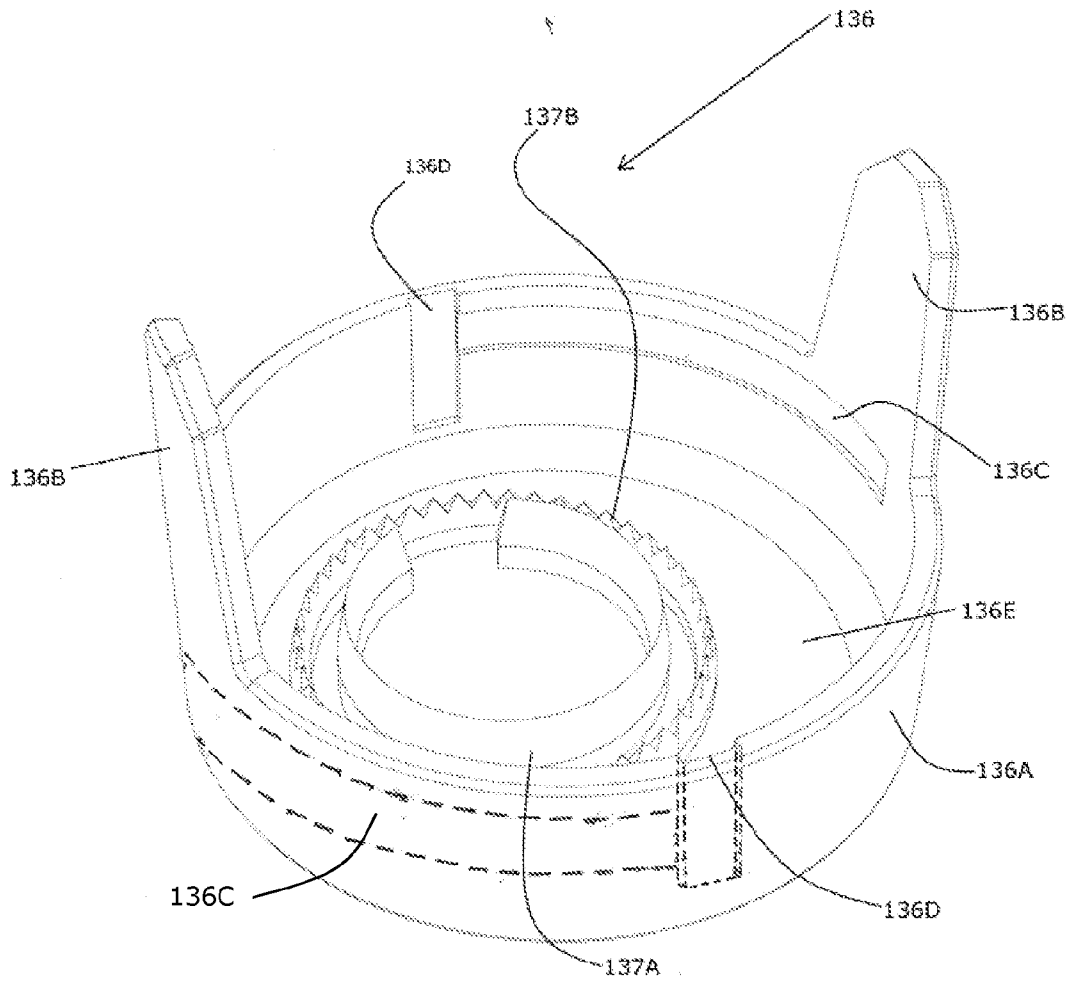

FIGURE 6C

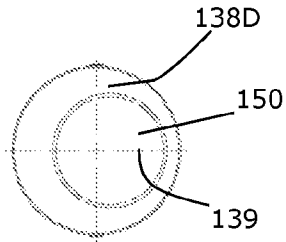

FIGURE 6D

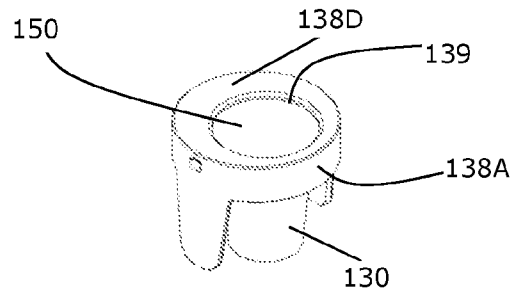

FIGURE 6E

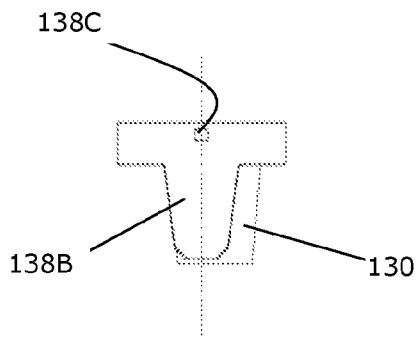

FIGURE 6F

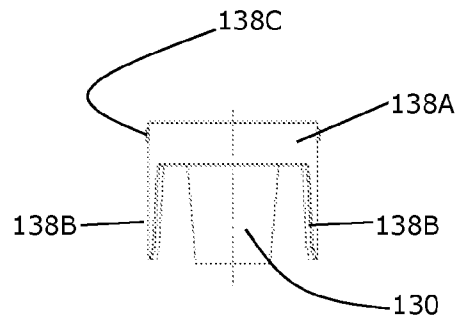

FIGURE 6G

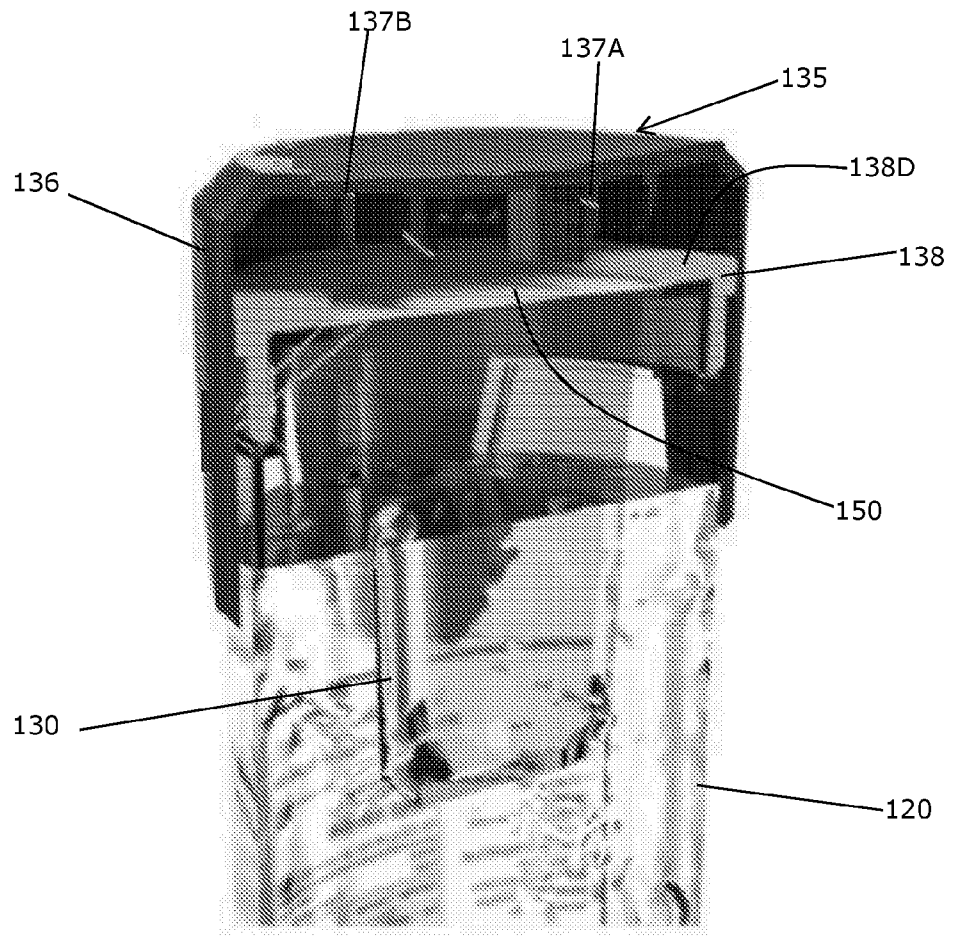

FIGURE 7

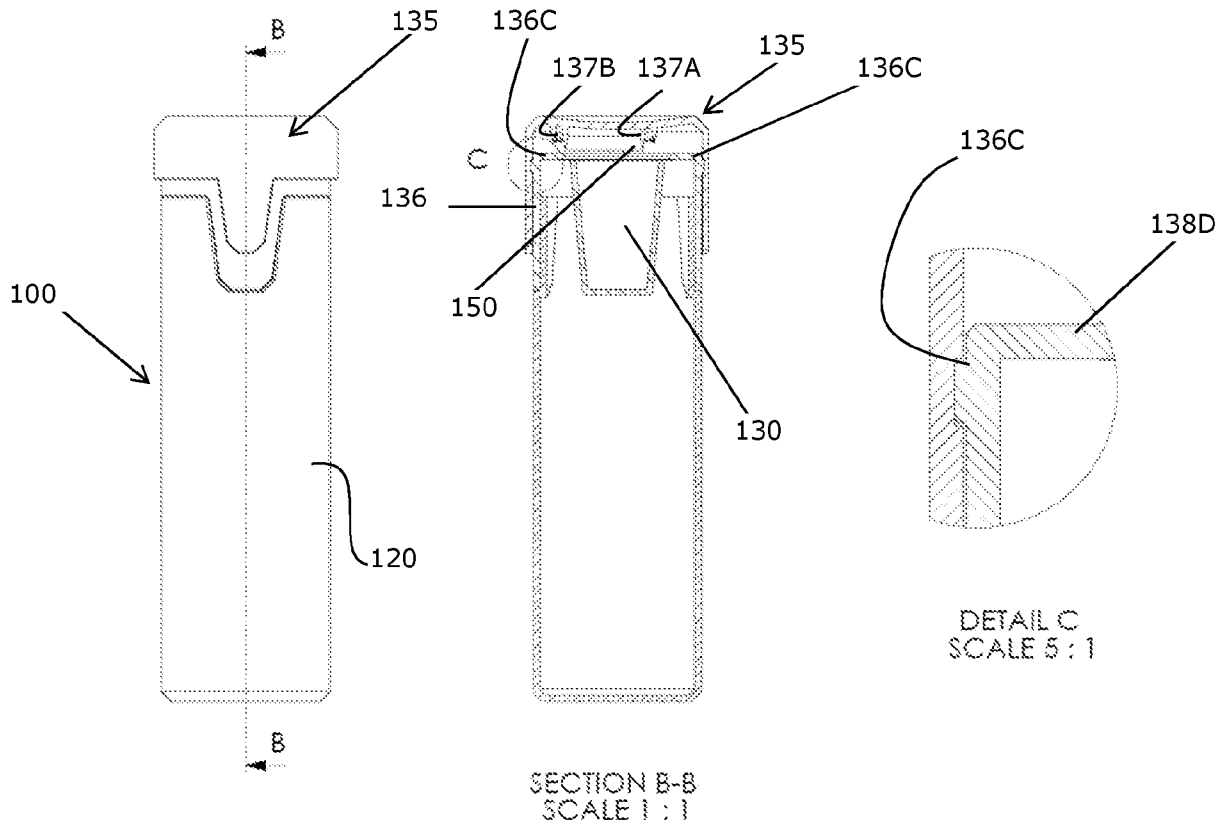

FIGURE 8A

FIGURE 8B

FIGURE 8C

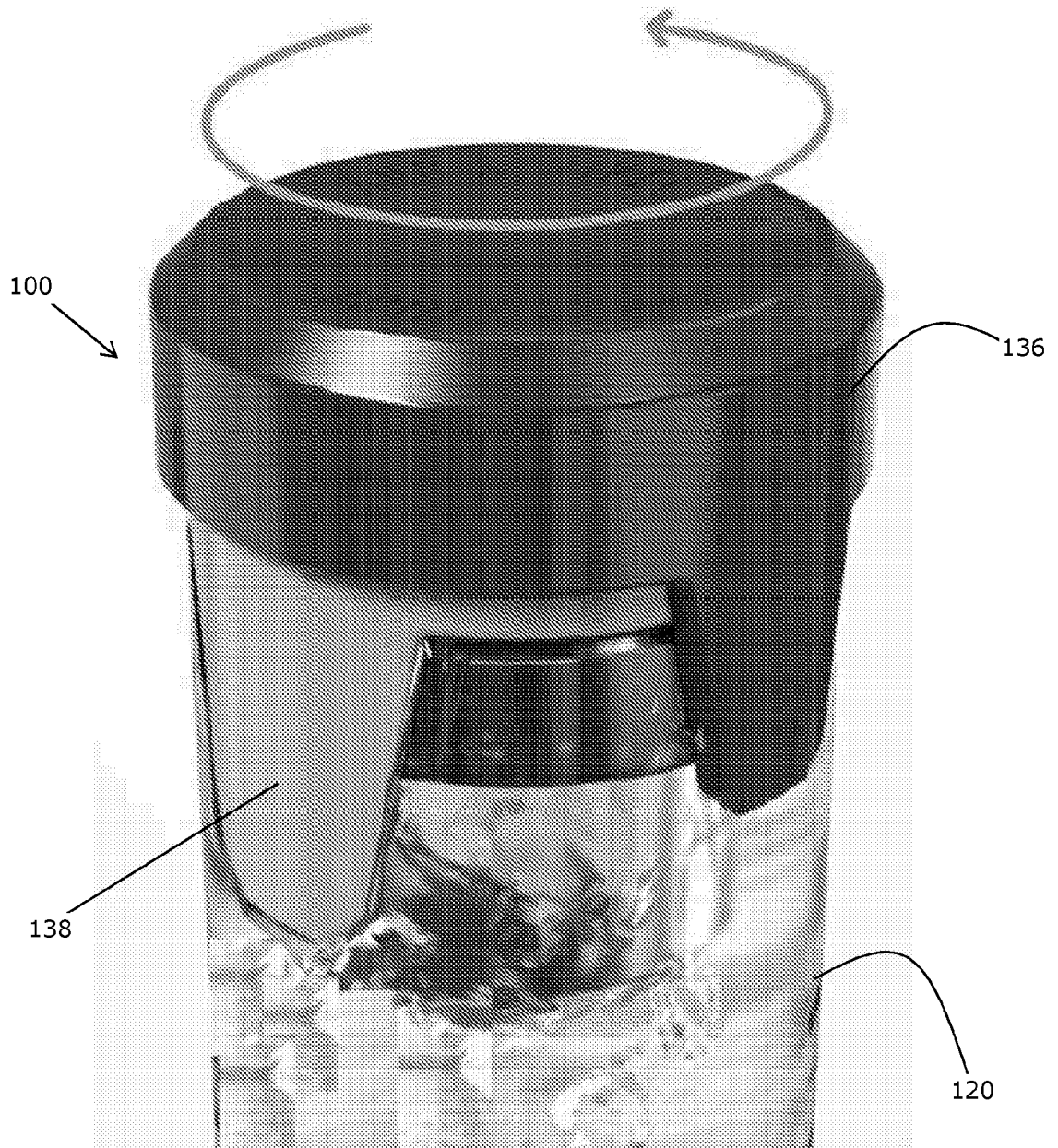

FIGURE 9

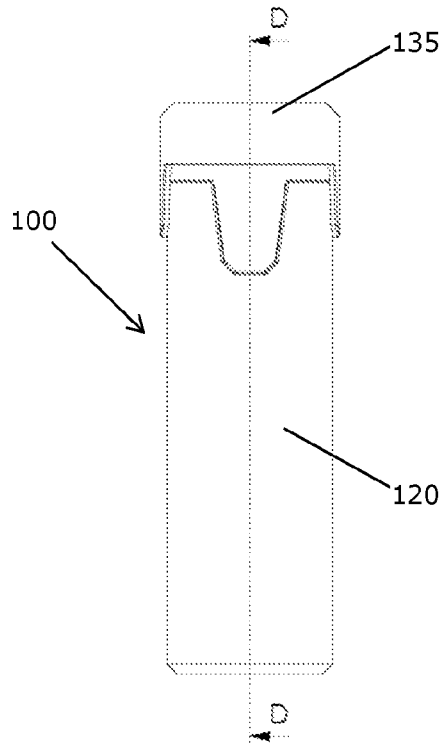

FIGURE 10A

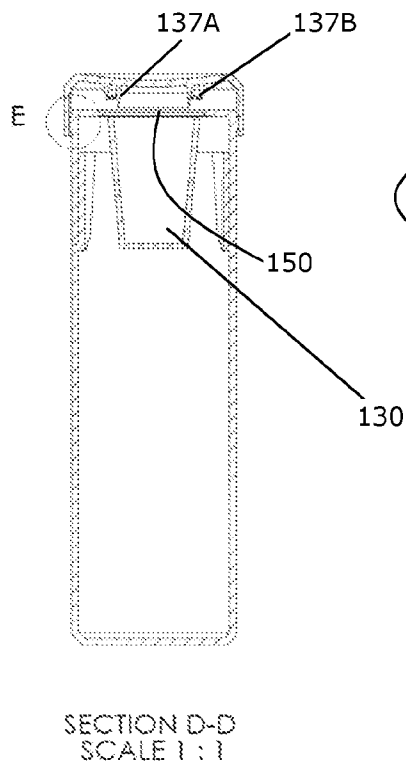

FIGURE 10B

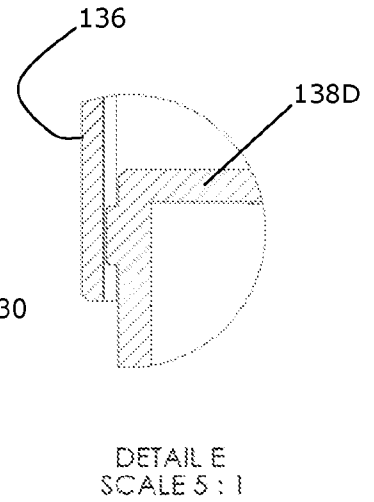

FIGURE 10C

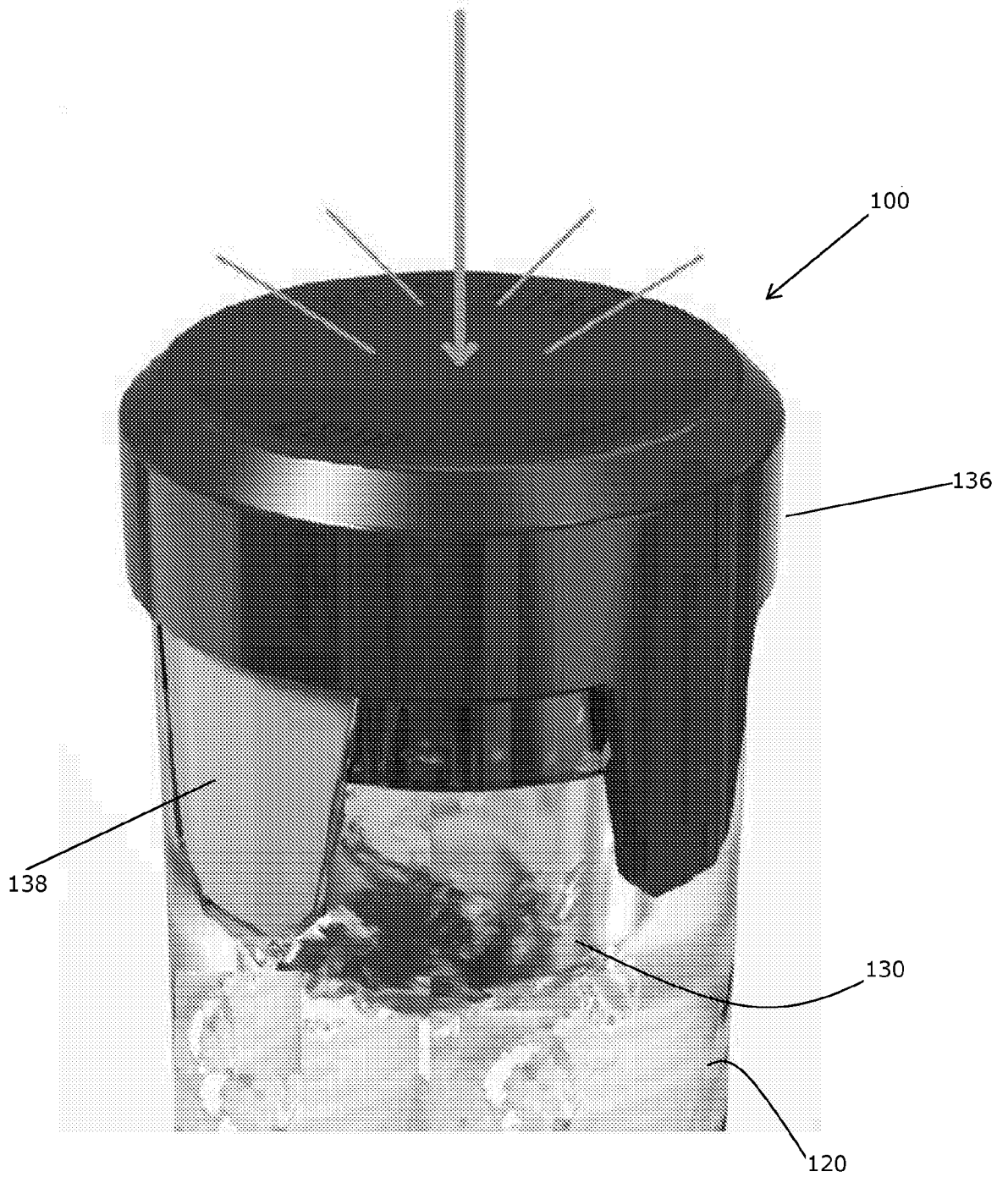

FIGURE 11

15/33

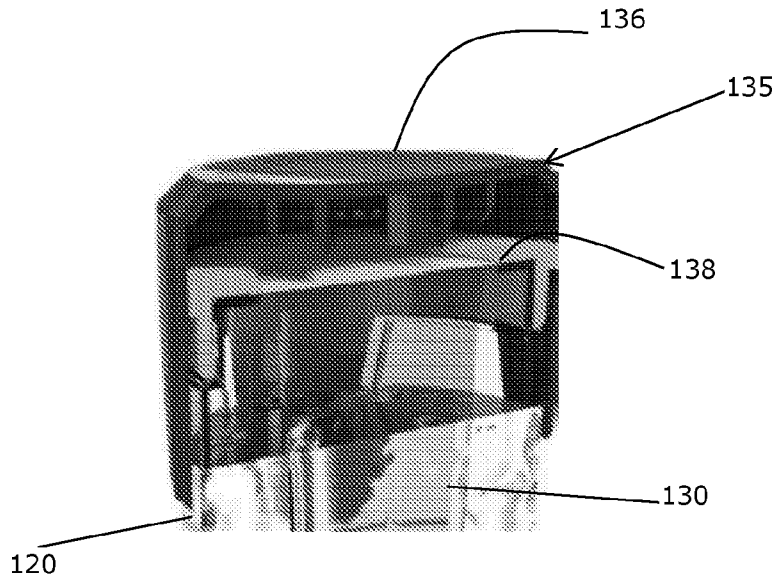

FIGURE 12A

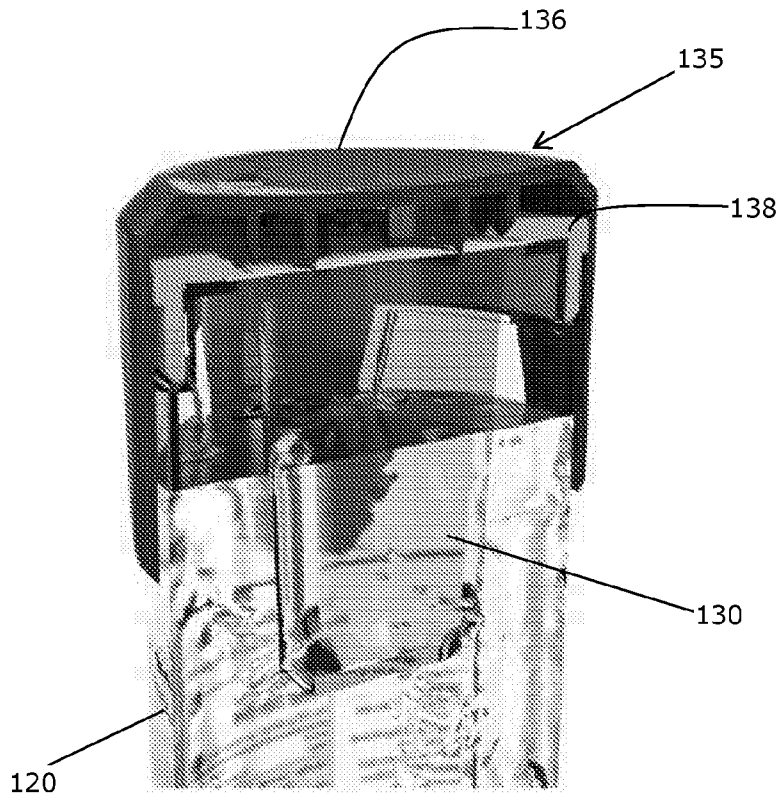

FIGURE 12B

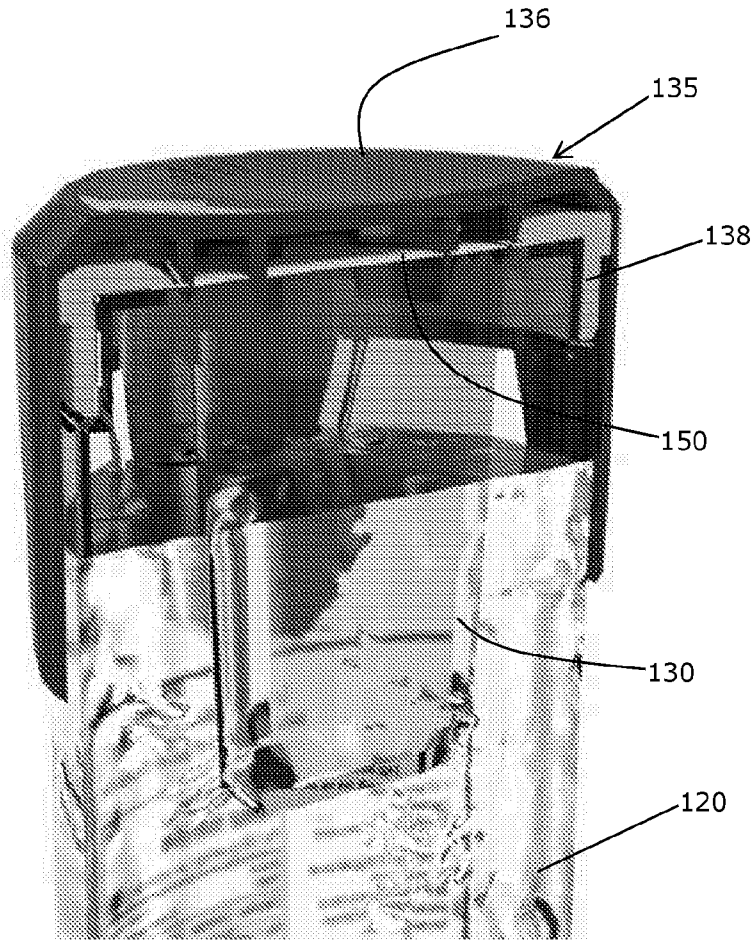

FIGURE 12C

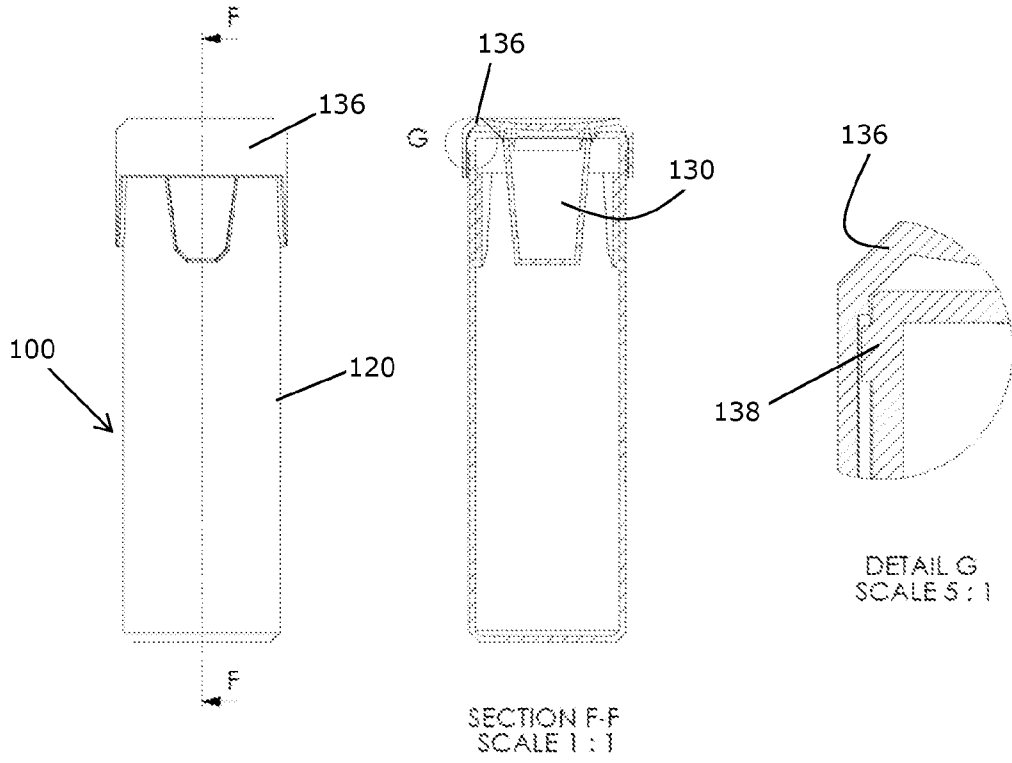

FIGURE 13A

FIGURE 13B

FIGURE 13C

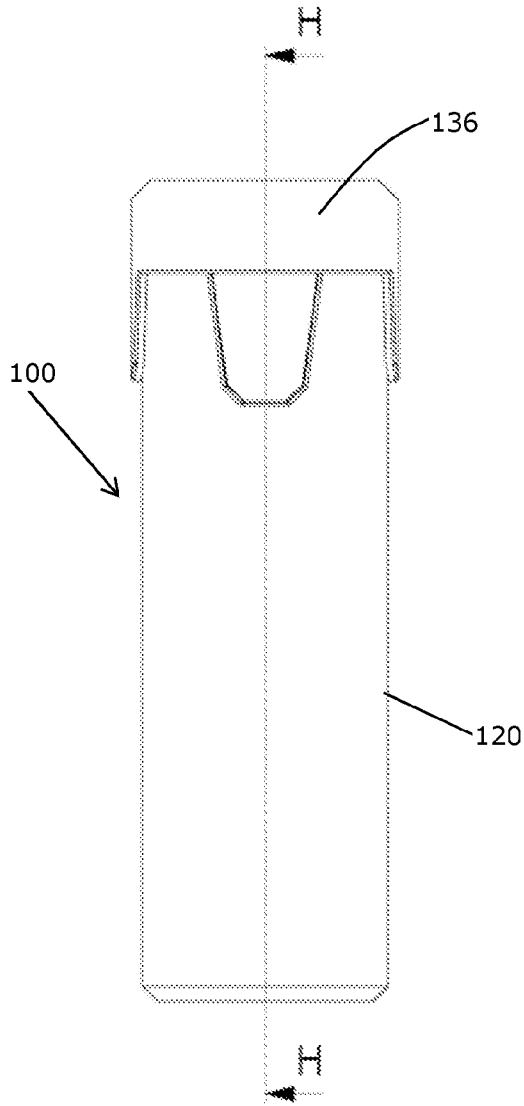
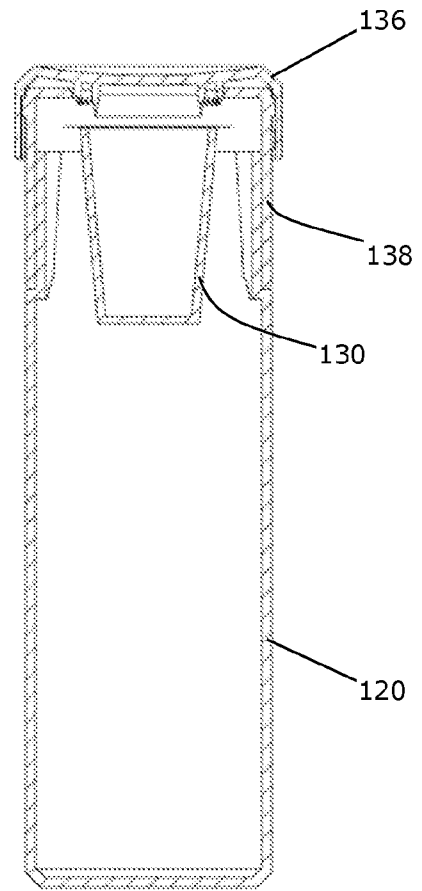

FIGURE 14A



SECTION H-H
SCALE 1 : 1

FIGURE 14B

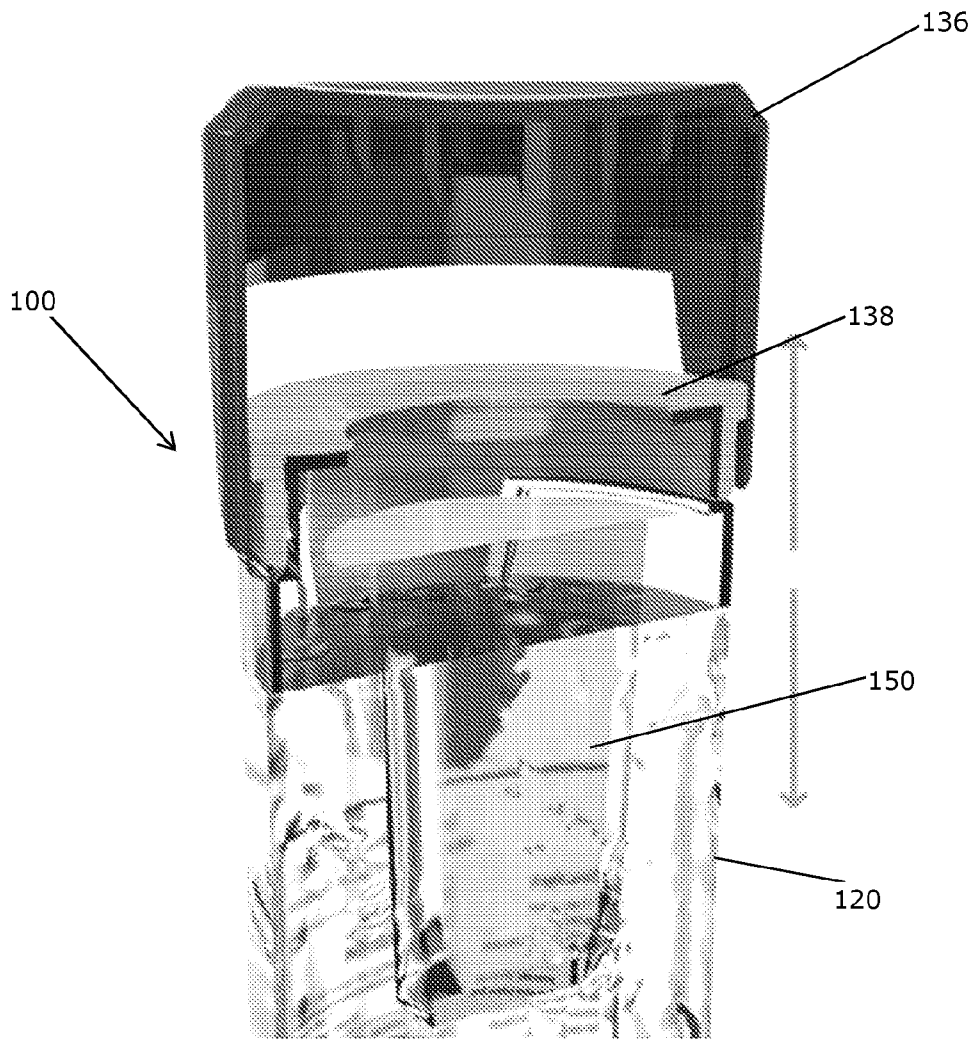

FIGURE 15

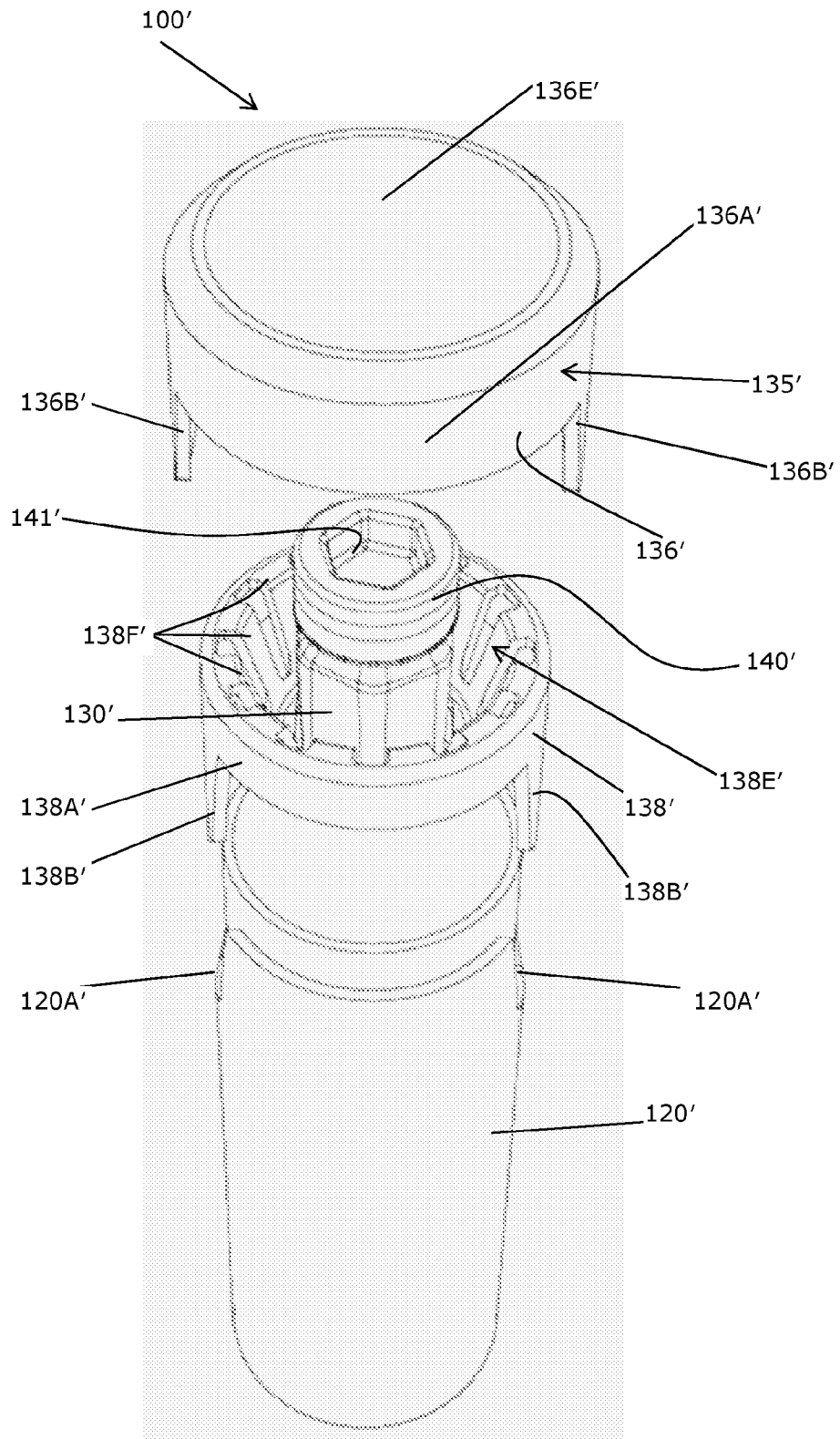

FIGURE 16A

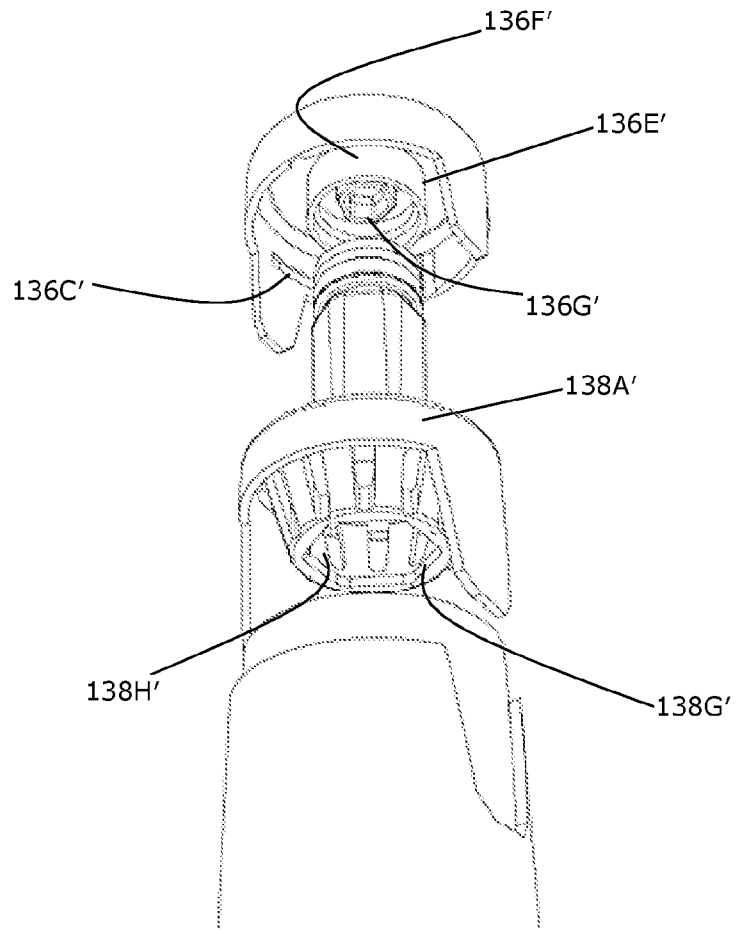

FIGURE 16B

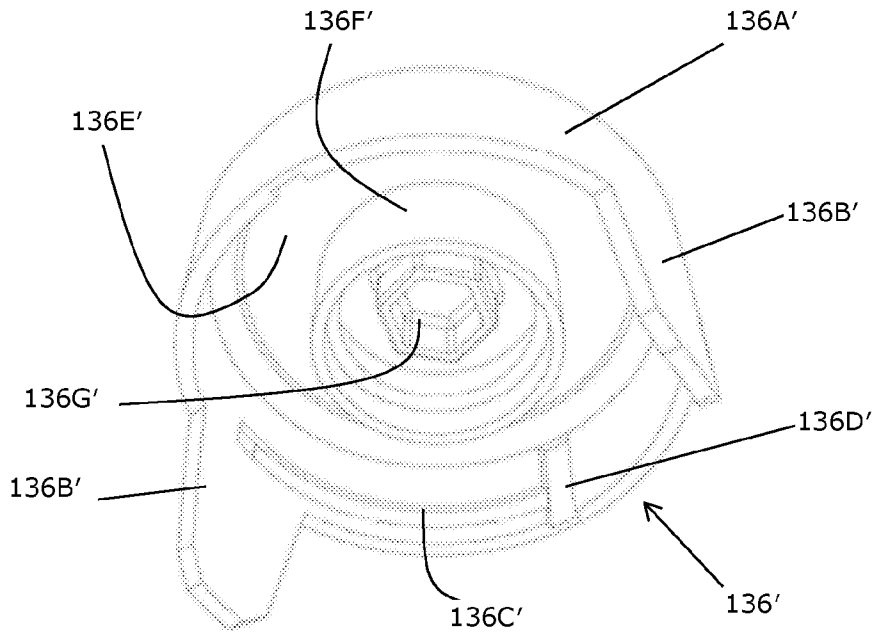

FIGURE 17A

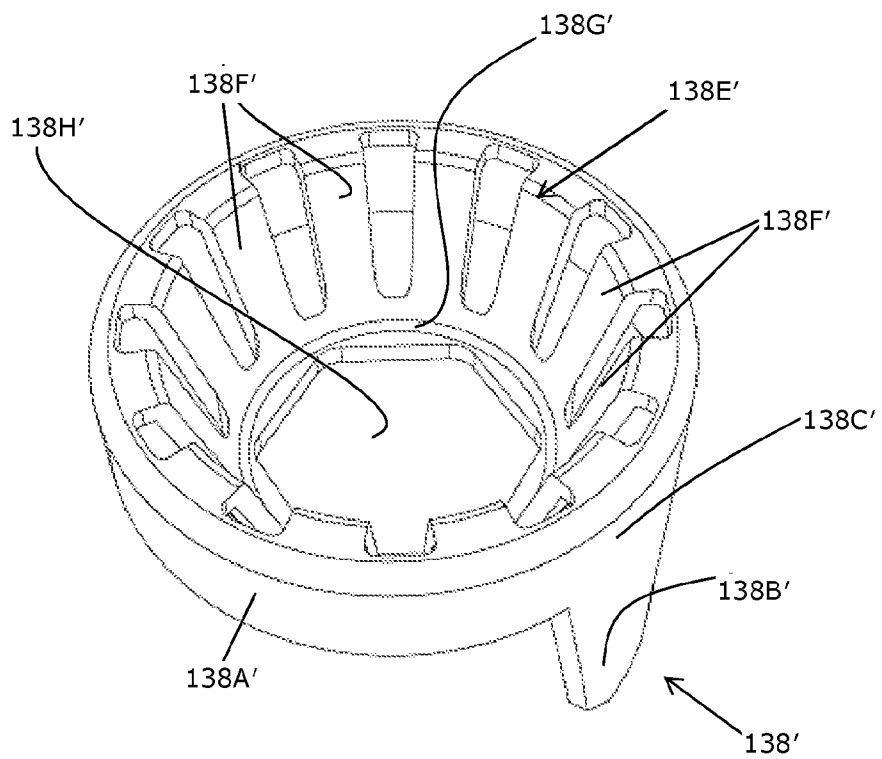

FIGURE 17B

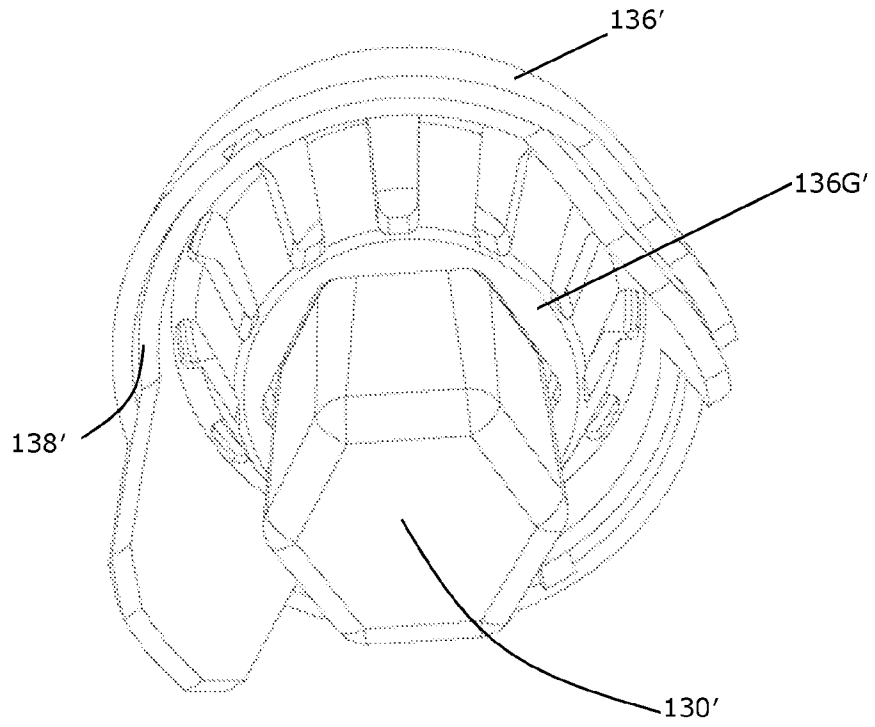

FIGURE 18A

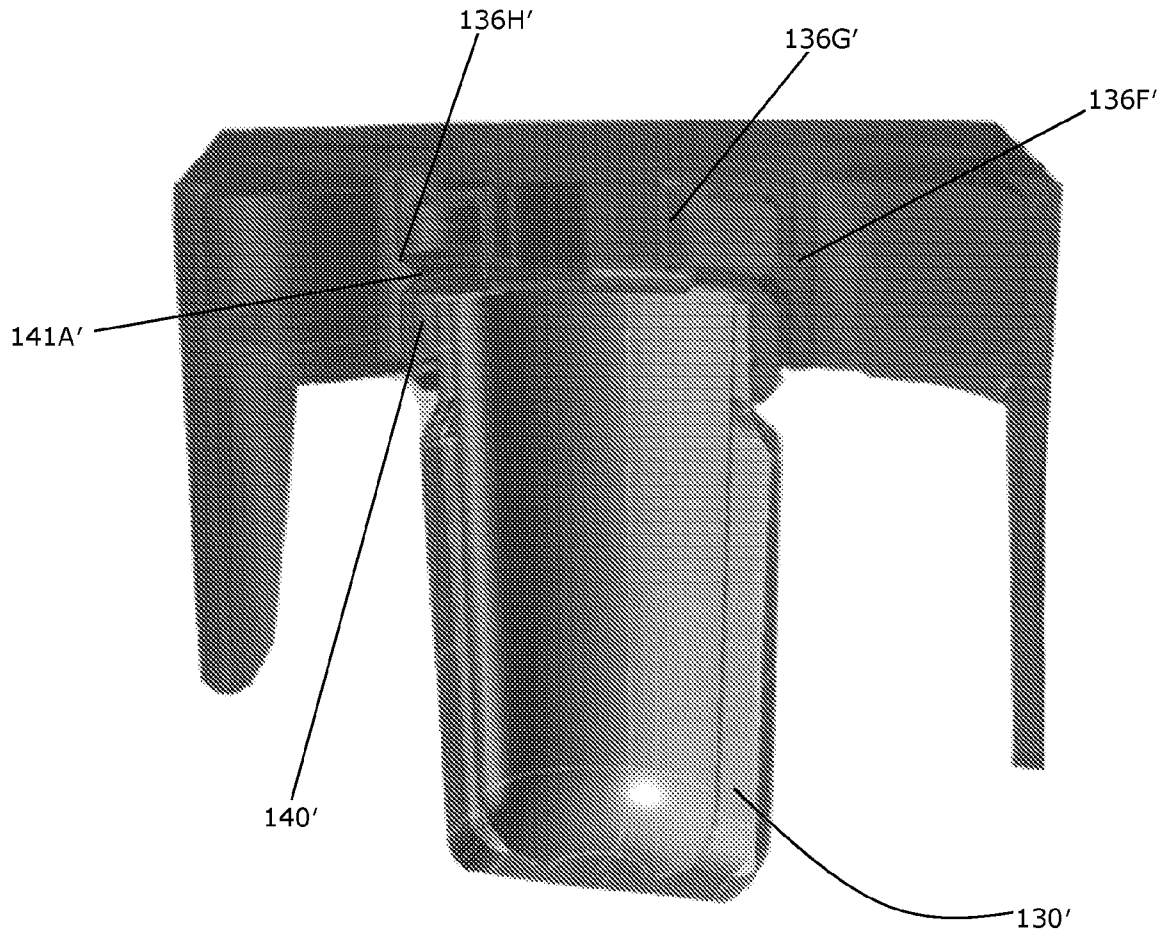

FIGURE 18B

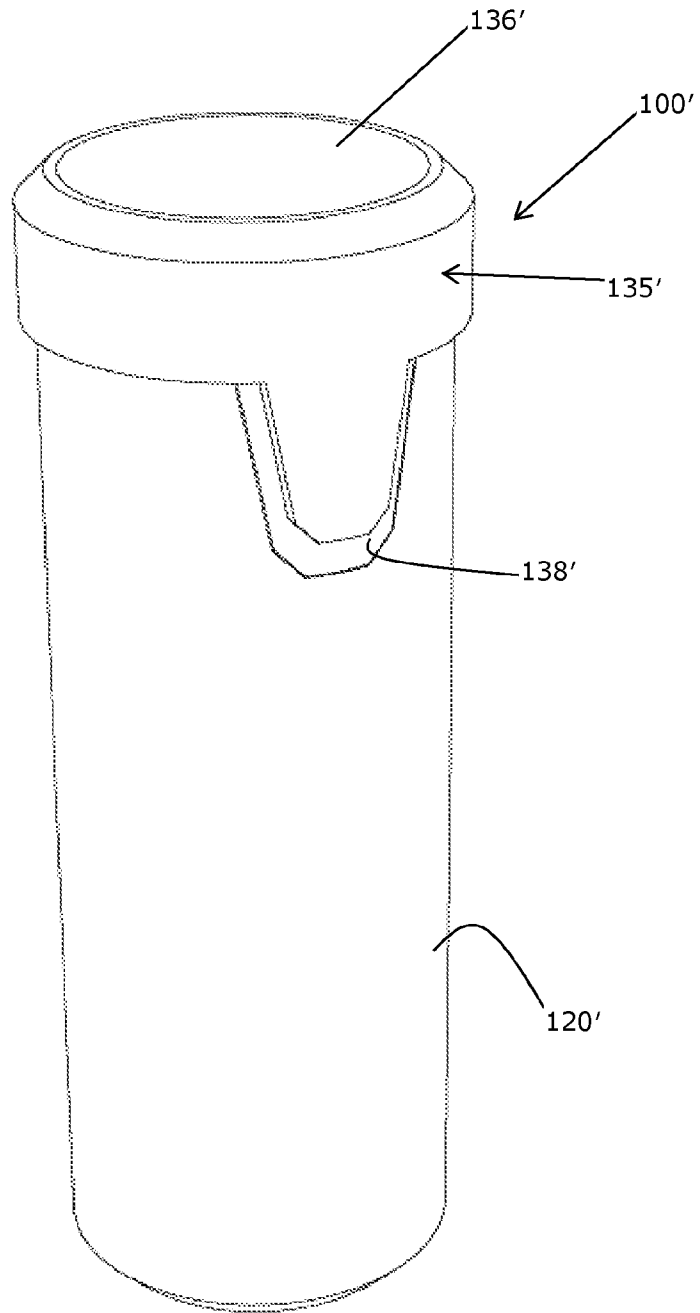

FIGURE 19

26/33

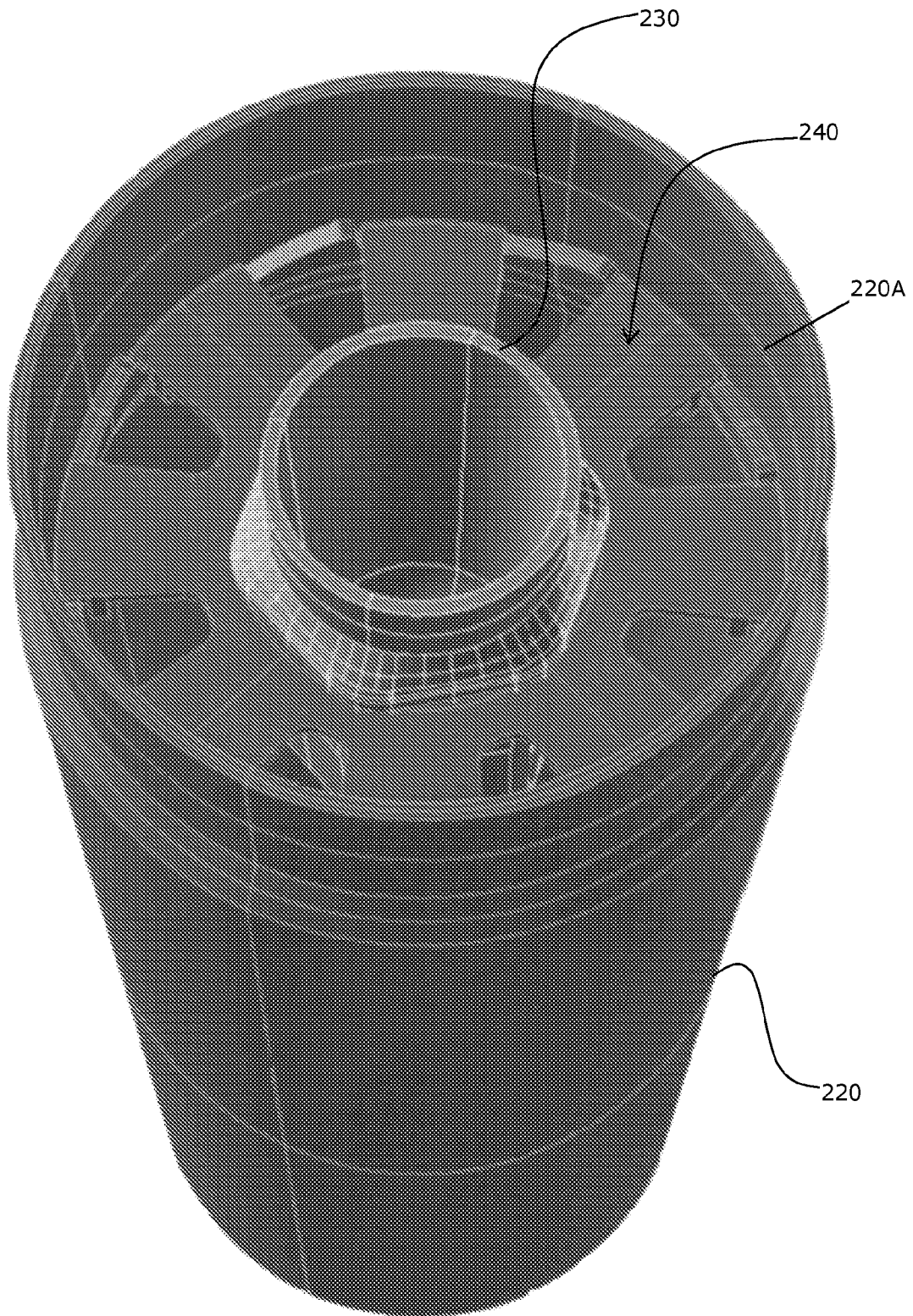

FIGURE 20A

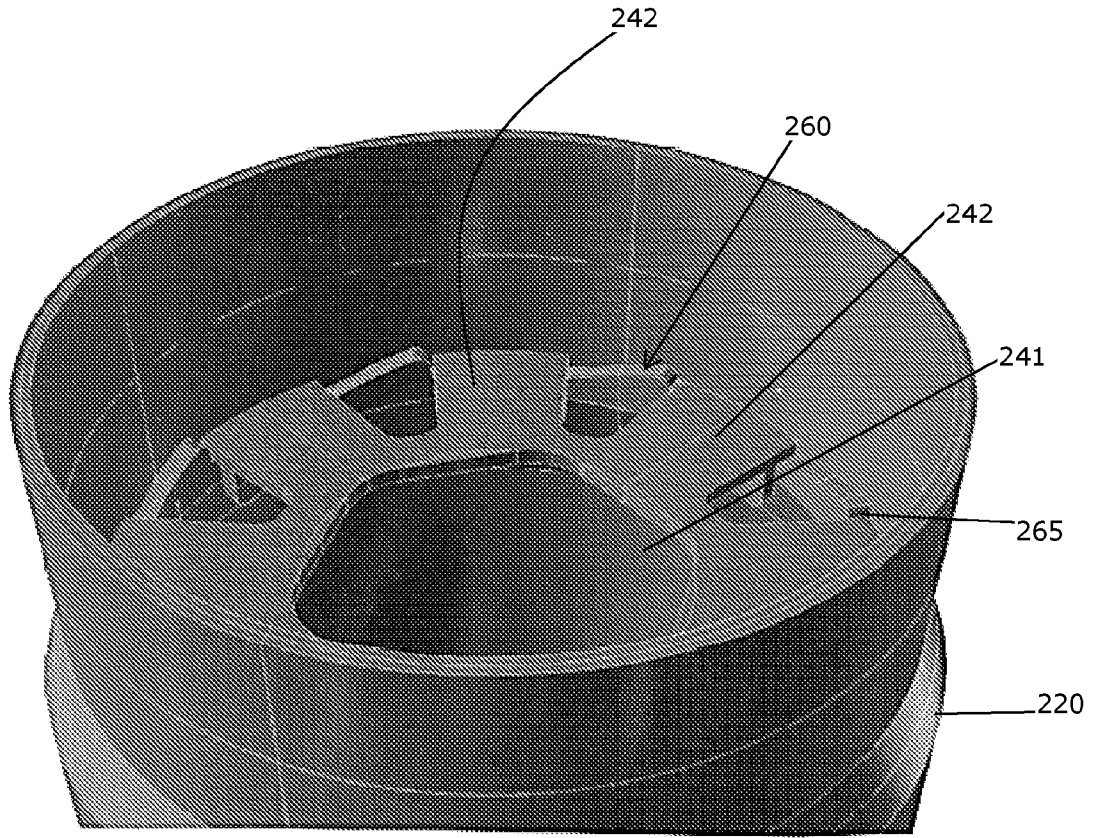

FIGURE 20B

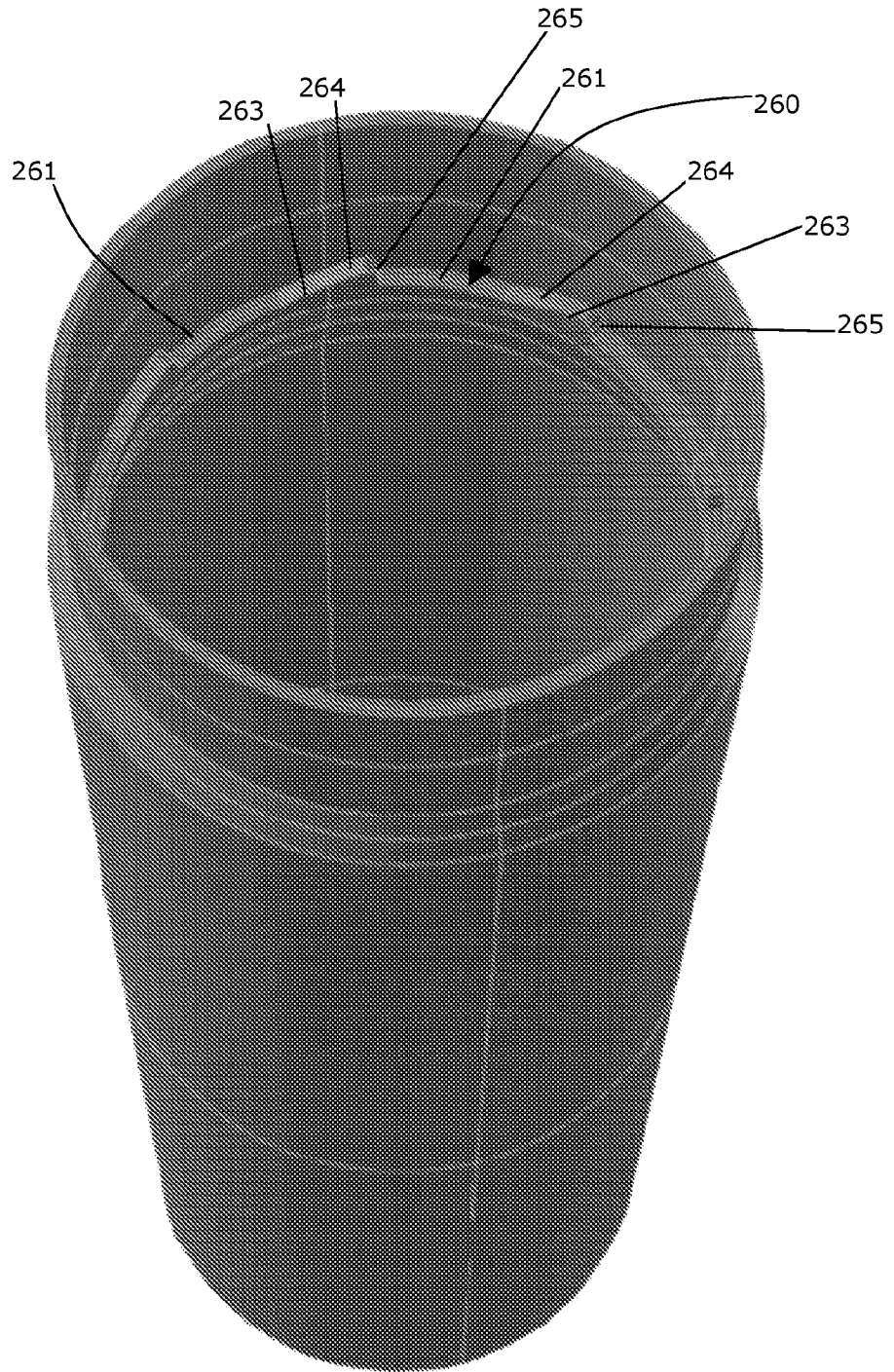
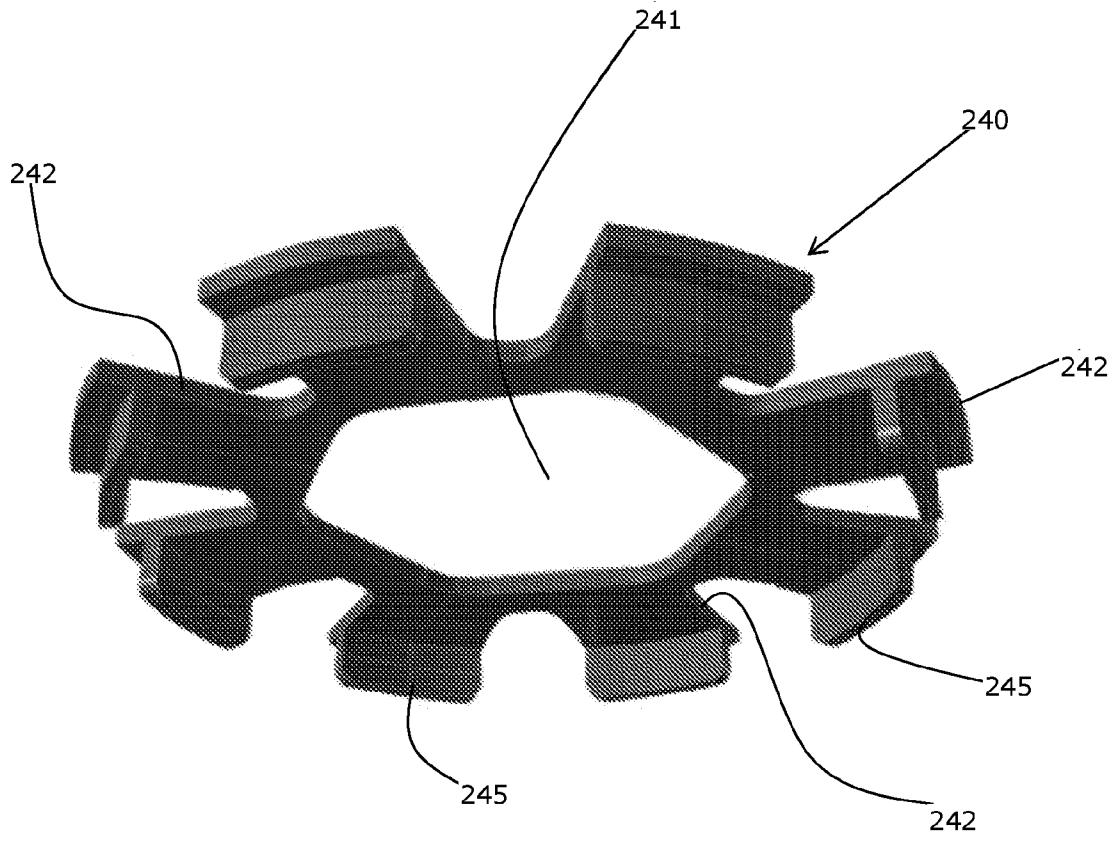

FIGURE 21A



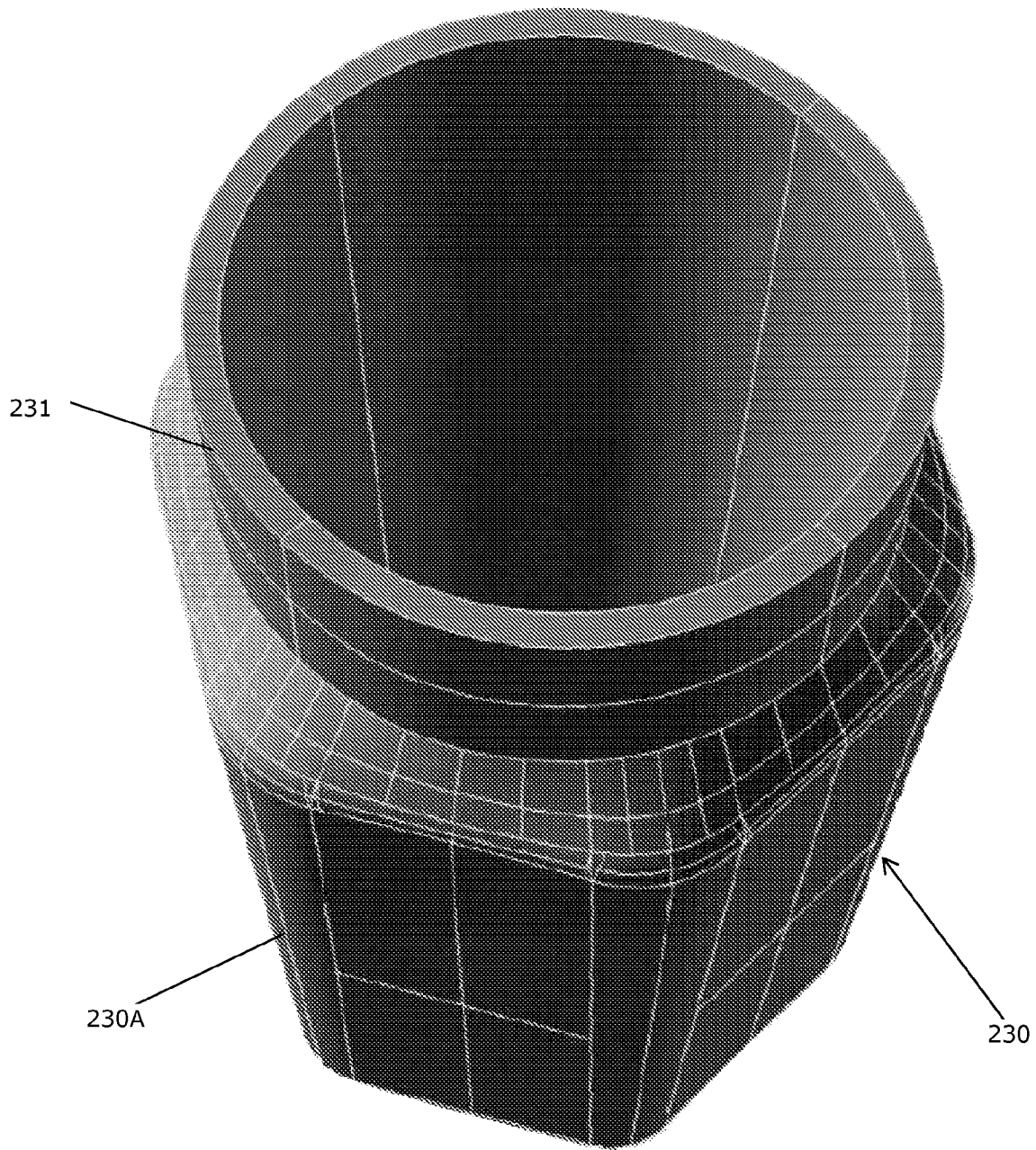

FIGURE 21C

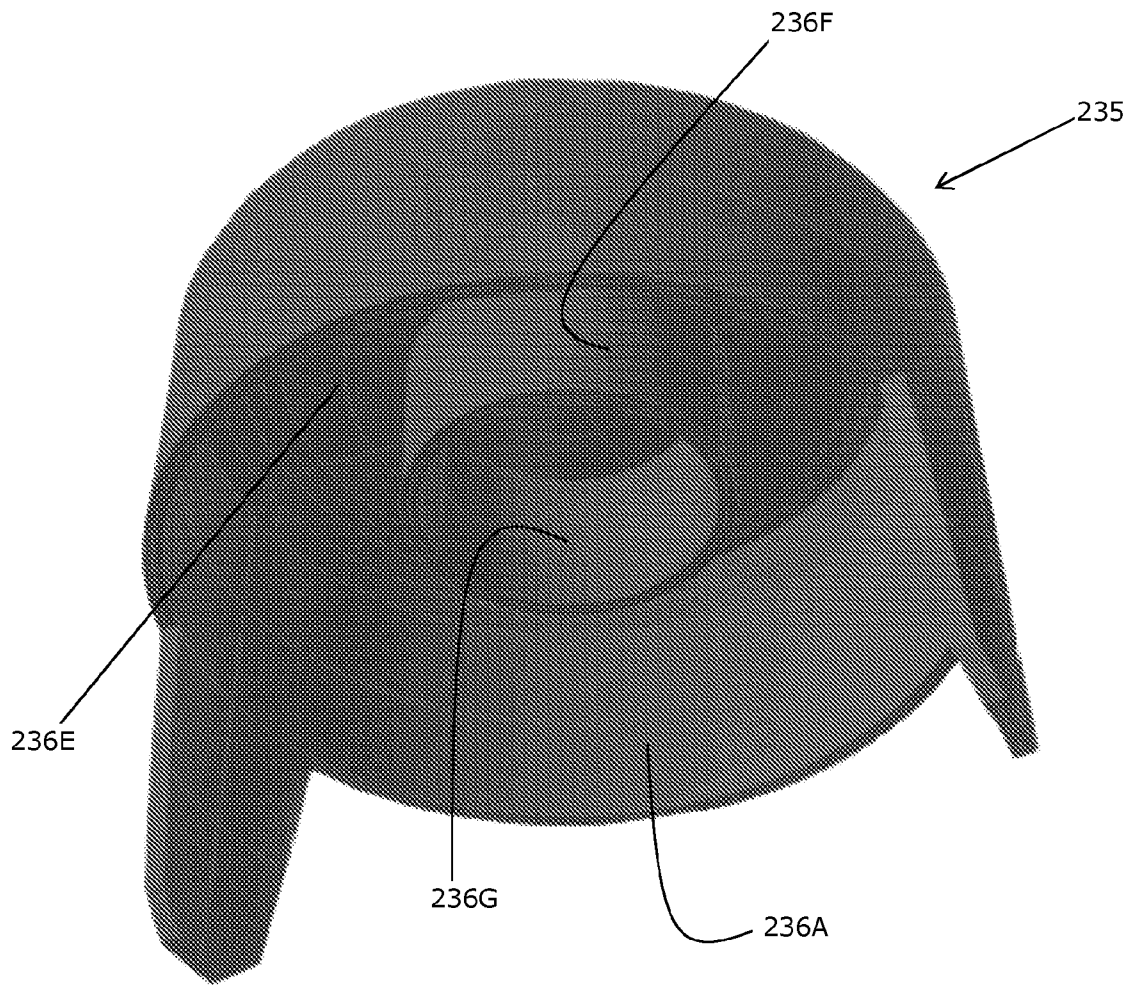

FIGURE 22

32/33

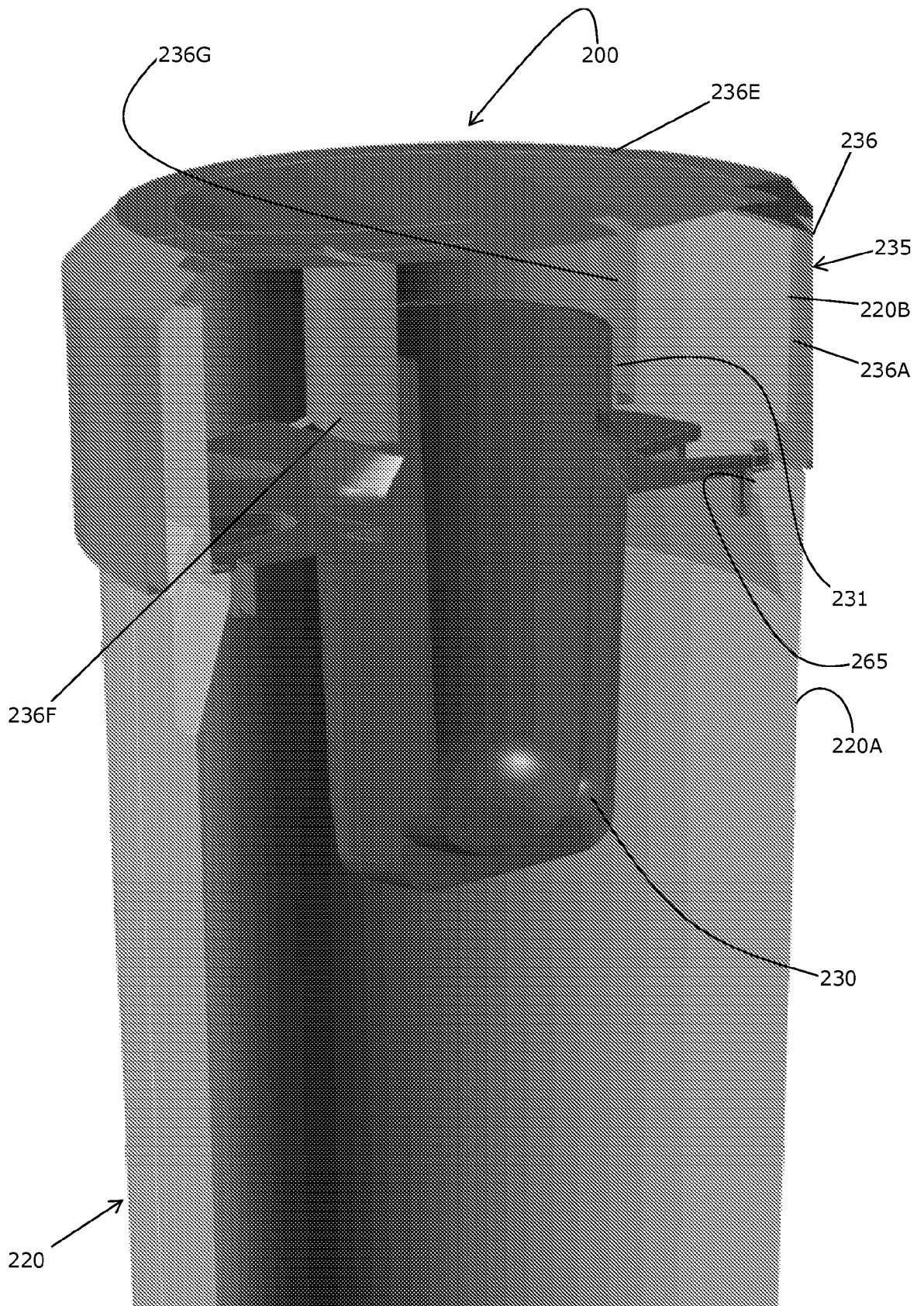

FIGURE 23A

33/33

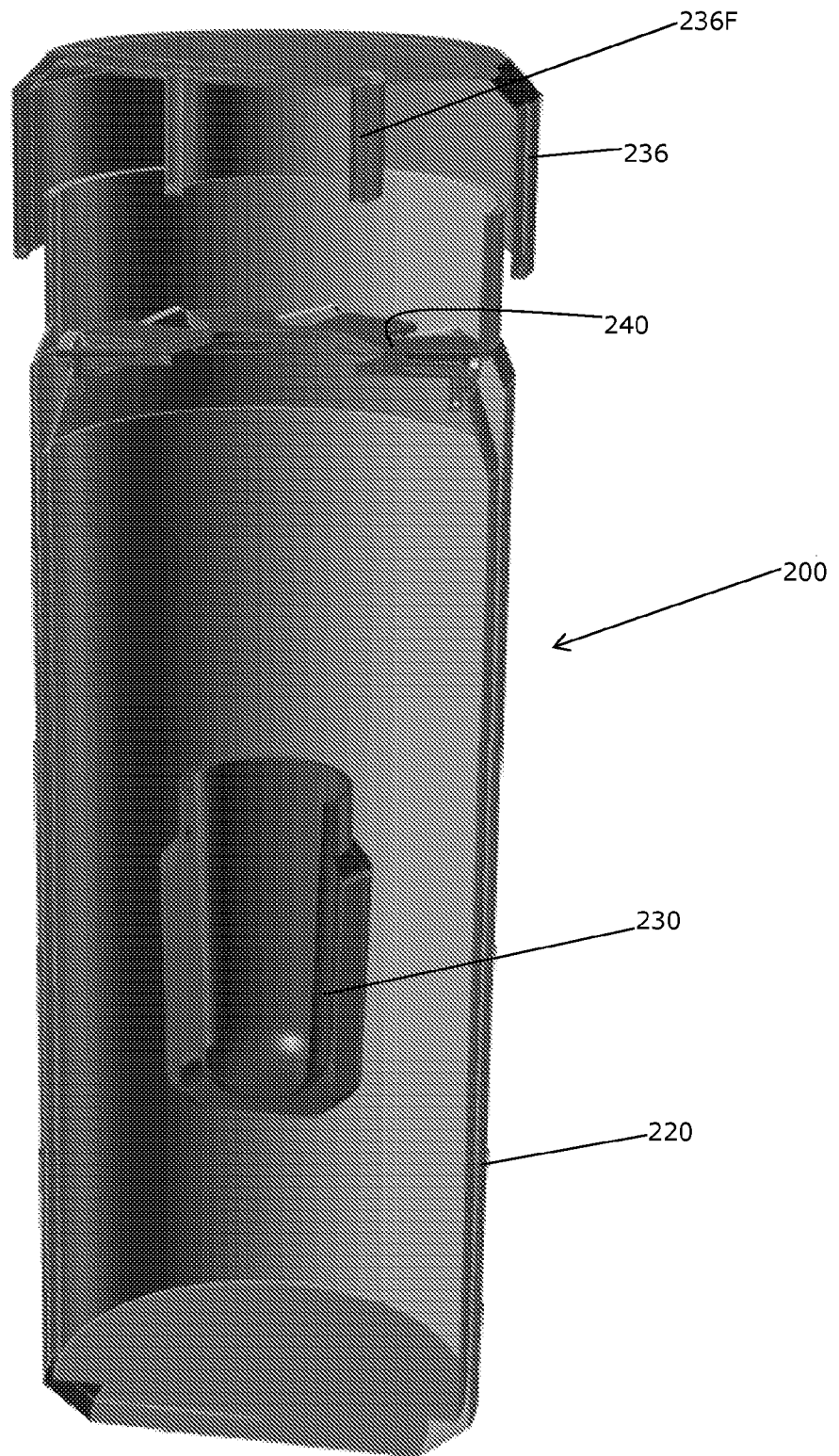

FIGURE 23B

INTERNATIONAL SEARCH REPORT

International application No.

PCT/AU2015/050143

A. CLASSIFICATION OF SUBJECT MATTER B65D 25/08 (2006.01) B65D 81/32 (2006.01) B65D 77/04 (2006.01)		
According to International Patent Classification (IPC) or to both national classification and IPC		
B. FIELDS SEARCHED		
Minimum documentation searched (classification system followed by classification symbols)		
Documentation searched other than minimum documentation to the extent that such documents are included in the fields searched		
Electronic data base consulted during the international search (name of data base and, where practicable, search terms used)		
Databases: WPIAP, EPODOC		
Index marks: (B65D25/08, B65D81/32, B65D81/3216, B65D77/04)/LOW and Keywords: (release, drop, letting go, let go, fall, descent, descend, gravity, glass, shot, cup, receptacle, container, vessel, shot glass, shooter, beverage, drink, compartment) and similar terms. Google Patents and ESPACENET searched using similar keywords, applicant and inventor name search also carried out on ESPACENET.		
C. DOCUMENTS CONSIDERED TO BE RELEVANT		
Category*	Citation of document, with indication, where appropriate, of the relevant passages	Relevant to claim No.
	Documents are listed in the continuation of Box C	
<input checked="" type="checkbox"/> Further documents are listed in the continuation of Box C <input checked="" type="checkbox"/> See patent family annex		
* "A"	Special categories of cited documents: document defining the general state of the art which is not considered to be of particular relevance	"T" later document published after the international filing date or priority date and not in conflict with the application but cited to understand the principle or theory underlying the invention
"E"	earlier application or patent but published on or after the international filing date	"X" document of particular relevance; the claimed invention cannot be considered novel or cannot be considered to involve an inventive step when the document is taken alone
"L"	document which may throw doubts on priority claim(s) or which is cited to establish the publication date of another citation or other special reason (as specified)	"Y" document of particular relevance; the claimed invention cannot be considered to involve an inventive step when the document is combined with one or more other such documents, such combination being obvious to a person skilled in the art
"O"	document referring to an oral disclosure, use, exhibition or other means	"&" document member of the same patent family
"P"	document published prior to the international filing date but later than the priority date claimed	
Date of the actual completion of the international search 8 May 2015	Date of mailing of the international search report 08 May 2015	
Name and mailing address of the ISA/AU AUSTRALIAN PATENT OFFICE PO BOX 200, WODEN ACT 2606, AUSTRALIA Email address: pct@ipaustrialia.gov.au	Authorised officer Clive Gaskin AUSTRALIAN PATENT OFFICE (ISO 9001 Quality Certified Service) Telephone No. 0262256108	

INTERNATIONAL SEARCH REPORT		International application No.
C (Continuation). DOCUMENTS CONSIDERED TO BE RELEVANT		PCT/AU2015/050143
Category*	Citation of document, with indication, where appropriate, of the relevant passages	Relevant to claim No.
X	US 2012/0103841 A1 (WINKLER) 03 May 2012 Paragraphs [0028], [0030], [0033], [0052], [0037], [0032], [0038], [0040], [0052] and figures 1, 2B and 6.	1 - 28
X	US 2009/0180923 A1 (GONG) 16 July 2009 Figures 1,2, 5 and paragraphs [0028] - [0035].	1 - 28
X	DE 202009012735 U1 (WUNN, MARTIN) 07 January 2010 Figure 1 and paragraphs [0008] - [0010]	1- 7, 10 – 13, 16 - 20
X	US 2004/0112770 A1 (OSWALD) 17 June 2004 Figures 1a, 1b, 3 and paragraphs [0065] - [0068].	1, 2, 5, 8 - 14, 16 - 23
A	US 2011/0290679 A1 (CASEY) 01 December 2011 Figure 1, abstract and paragraphs [0026] - [0028].	1 - 28

INTERNATIONAL SEARCH REPORT

Information on patent family members

International application No.

PCT/AU2015/050143

This Annex lists known patent family members relating to the patent documents cited in the above-mentioned international search report. The Australian Patent Office is in no way liable for these particulars which are merely given for the purpose of information.

Patent Document/s Cited in Search Report		Patent Family Member/s	
Publication Number	Publication Date	Publication Number	Publication Date
US 2012/0103841 A1	03 May 2012		
US 2009/0180923 A1	16 July 2009	US 8328032 B2	11 Dec 2012
		AU 2007207249 A1	26 Jul 2007
		AU 2007207249 B2	12 Aug 2010
		BR PI0707158 A2	26 Apr 2011
		CA 2635693 A1	26 Jul 2007
		CN 101360659 A	04 Feb 2009
		CN 101360659 B	02 Jun 2010
		EP 1975080 A1	01 Oct 2008
		EP 1975080 B1	17 Nov 2010
		JP 2009523664 A	25 Jun 2009
		JP 4825880 B2	30 Nov 2011
		KR 20080094700 A	23 Oct 2008
		KR 101074105 B1	17 Oct 2011
		WO 2007082464 A1	26 Jul 2007
DE 202009012735 U1	07 January 2010		
US 2004/0112770 A1	17 June 2004	US 7210575 B2	01 May 2007
		AU 2003262519 A1	23 Apr 2004
		CA 2500282 A1	15 Apr 2004
		DE 10245172 A1	01 Apr 2004
		EP 1546002 A1	29 Jun 2005
		EP 1546002 B1	17 May 2006
		JP 2006500180 A	05 Jan 2006
		JP 4467434 B2	26 May 2010
		WO 2004031047 A1	15 Apr 2004
US 2011/0290679 A1	01 December 2011	US 8720680 B2	13 May 2014
		EP 2190751 A2	02 Jun 2010
		EP 2190751 B1	27 Feb 2013
		US 2009065379 A1	12 Mar 2009
		US 7861855 B2	04 Jan 2011
		WO 2009032939 A2	12 Mar 2009

End of Annex

Due to data integration issues this family listing may not include 10 digit Australian applications filed since May 2001.

Form PCT/ISA/210 (Family Annex)(July 2009)