

P. E. SMITH.
 CEMENT POST MACHINE.
 APPLICATION FILED MAY 23, 1910.

998,131.

Patented July 18, 1911.

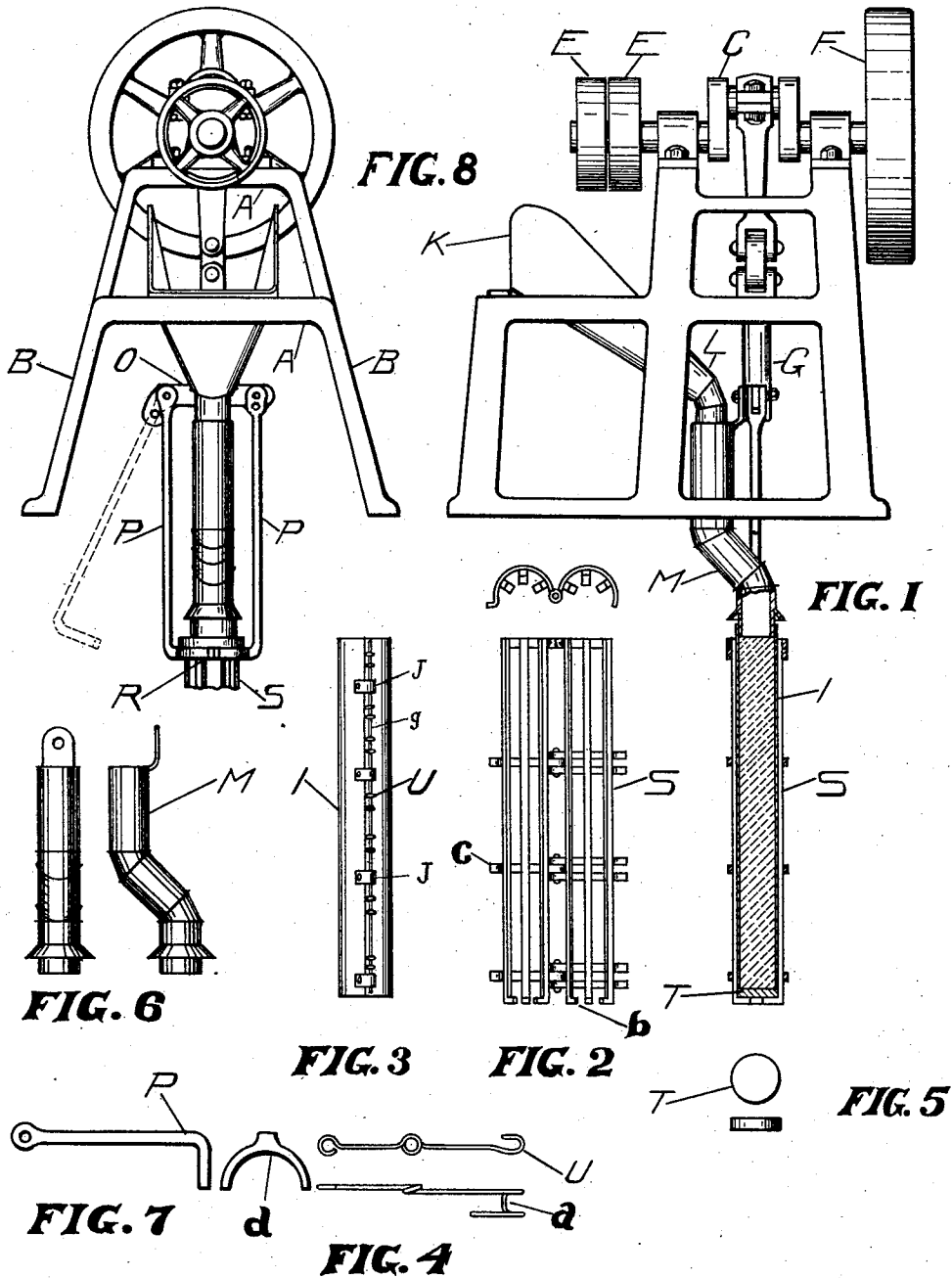

WITNESSES.

Clifford L. Smith
Andrew H. Smith

INVENTOR.

Curry & Smith

UNITED STATES PATENT OFFICE.

PERRY E. SMITH, OF DETROIT, MICHIGAN.

CEMENT-POST MACHINE.

998,131.

Specification of Letters Patent. Patented July 18, 1911.

Application filed May 23, 1910. Serial No. 583,025.

To all whom it may concern:

Be it known that I, PERRY E. SMITH, a citizen of the United States, residing at Detroit, county of Wayne, and State of Michigan, have invented a new and useful Cement-Post Machine, of which the following is a specification.

This invention relates to machines for making artificial stone posts and has for its object to provide a molding machine in which the tamping of the concrete is effected by intermittently jarring the mold, thereby to thoroughly pack the concrete and thus provide a post of uniform density.

A further object of the invention is to provide a machine including a main frame with feeding-hopper secured thereto, a crank-shaft mounted thereon carrying a pitman to which is secured a feeding spout actuated in conjunction with said pitman, said feeding-spout supplying a means of passage for the concrete from feeding-hopper to mold.

A still further object of the invention is to generally improve the methods of post making and facilitate the work thereof.

Further objects and advantages will appear in the following description, it being understood that various changes in form, proportions and minor details of construction may be resorted to within the scope of the appended claim.

In the accompanying drawings forming a part of this specification, Figure 1 is an elevation of the entire machine. Fig. 2 a view of shell-supporting frame as it appears when detached and open. Fig. 3 shell as it appears when closed. Fig. 4 double wire staple before placed in shell. Fig. 5 end closure-plate. Fig. 6 independent feeding-spout. Fig. 7 tongs terminating in half circles. Fig. 8 an end view of the machine.

Similar letters refer to similar parts throughout the several views.

The improved machine forming the subject matter of the present invention includes a main frame with cross-ties A A and standards B B. To the main frame is secured a feeding-hopper K provided with a reduced funnel shaped mouth L through which the concrete is fed into the independent feeding-spout M through which it is fed into the sheet-metal shell I disposed within the supporting-frame S. Mounted on the top of said main frame are journal-boxes in which is disposed a crank-shaft C carrying fly-

wheel F and loose and tight pulleys E E. A vertical double-action pitman G is pivotally connected to the crank-shaft C, with feeding-spout M secured thereon and actuated in conjunction therewith. A cross-arm O is pivotally disposed within an aperture in lower end of pitman. Tongs-shafts P, P, are secured to (one of them rigidly, the other pivotally) ends of cross-arm O, said tongs-shafts terminating in transverse half circles *d* forming a clutch R (when both shafts are down). A shell-supporting-frame S is grasped at the top by said clutch and the shell I is disposed within said supporting-frame. A closure-plate T is placed within lower end of supporting frame. Double staples U are inserted through staple holes in shell, a wire rod *g* passed through them and through loops J J on opposite edge of shell.

To prepare the shell for holding and forming the concrete: After placing the staples through staple-holes in the shell and passing a light wire through them (on outer side of shell) the edges of the shell are brought together and passed by each other so as to bring the staples and loops in alignment. The light wire is then drawn out of staples, a heavy wire-rod *g* put in its place and at same time passed through loops secured to opposite edge of shell, serving the double purpose of holding the shell closed and holding the staples out until the concrete is sufficiently set to admit removal of shell from same. Said staples are kept from projecting out (too far) by the short part of wire staple (between each pair) pressing against inner side of material of shell between the staple-holes.

The shell supporting-frame is made in (two sections) with longitudinal bars of band-iron having transverse bands of same material secured to same and provided with hinges to admit of the opening and closing of same, and with hasps and staples *c* to hold it securely when closed and with flanges *b* at lower end for a support for shell I and end closure-plate T.

To produce uniformity and density of the concrete, a block of wood faced with boiler-steel is set "in concrete" in the ground directly underneath the supporting-frame to receive the jar essential to the thorough tamping of the concrete.

While the machine as described is essentially a fence-post machine it will be understood that it may be used for making

house-posts, hitching posts, mile-posts, building-block, pipe, columns, or telephone-poles by changing the configuration of the mold.

5 The shaft C is driven by motor by a belt passing around the pulleys E E.

To remove the shell "containing concrete" from supporting frame the bolt "in cross-arm" that keeps the pivotal tongs-shaft "when down" to its place is withdrawn, the said shaft raised to free the top of supporting-frame, the hasps are thrown off from the staples, the frame swung open, and the bottom end of shell containing the molded post is set on a tram and removed to any location desired, being always kept in an upright position until thoroughly cured.

When the concrete is set, sufficient to allow the removal of the shell A from same the wire-rod in staples and loops is drawn by means of a rope and tackle "to which a wire clutch is secured" which releases the shell which is then sprung apart and removed and again used as before.

The crank-shaft C "with crank near the center" disposed within the (head) upper end of pitman operates to produce the intermittent motion desired.

30 The independent feeding-spout M "secured to pitman G" works between the stationary feeding-hopper K and sheet metal shell I, the lower end (mouth) of feeding-

hopper entering into upper end of said feeding-spout and the upper end of sheet metal shell A receiving lower end of same, the said spout being secured to said pitman and the tongs-shafts P P secured to cross-arm of same and clutching top of supporting-frame S are all operated in unison by crank-shaft C.

I am aware that prior to my invention that cement post machines have been made with an intermittent motion. I therefore do not claim such a combination broadly; but

I claim

A cement post machine comprising a main frame, a crank shaft located on said frame, means for rotating said crank shaft, a pitman depending from the crank portion of said shaft, a cross arm secured to lower end of said pitman, tong shafts secured to said cross arm, a supporting frame suspended by said tong-shafts, a hopper rigidly secured on said main frame and a feeding spout leading from said hopper to said mold, secured to said pitman and adapted to reciprocate therewith.

In testimony that I claim the foregoing as my own, I have hereto set my hand in the presence of two witnesses.

PERRY E. SMITH.

Witnesses:

CLIFFORD P. SMITH,
ANDREW W. SMITH.

Copies of this patent may be obtained for five cents each, by addressing the "Commissioner of Patents, Washington, D. C."