

997,316.

Patented July 11, 1911.

3 SHEETS—SHEET 1.

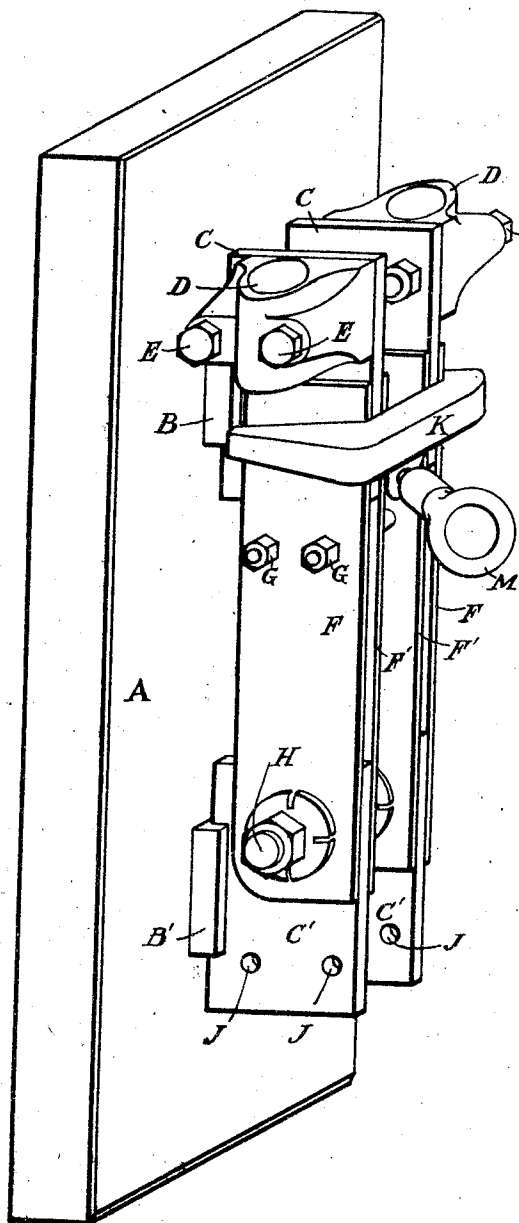

Fig. 1.

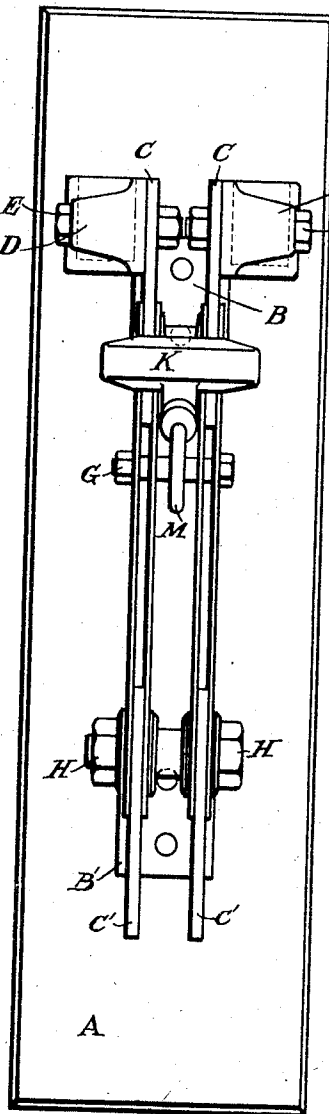

Fig. 2.

Witnesses.
 Harry Alexander
 Robert K. Buzzell

Inventors
 John Morse
 Frederick Thomas Kaelin
 per Clarence Thomson
 Attorney

997,316.

Patented July 11, 1911.

3 SHEETS—SHEET 2.

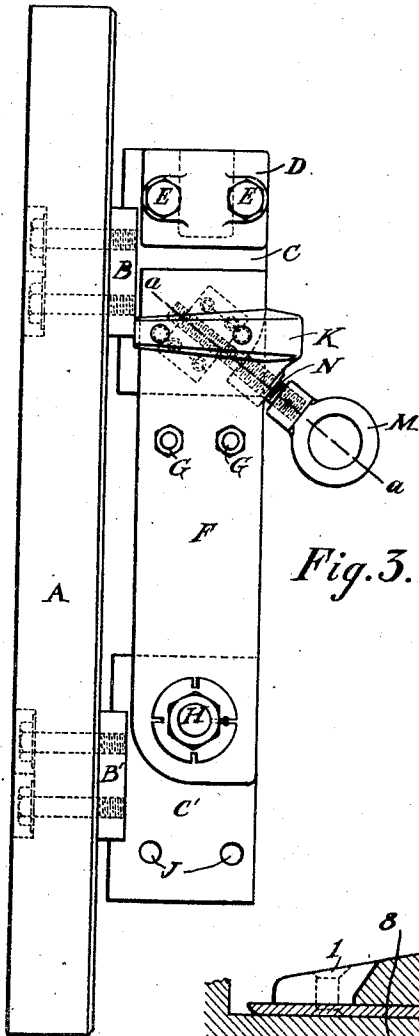

Fig. 3.

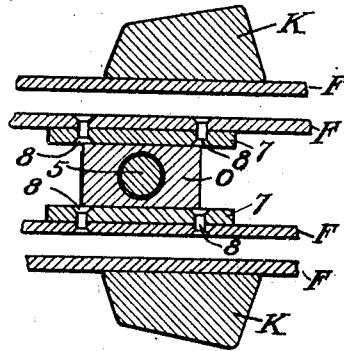

Fig. 5.

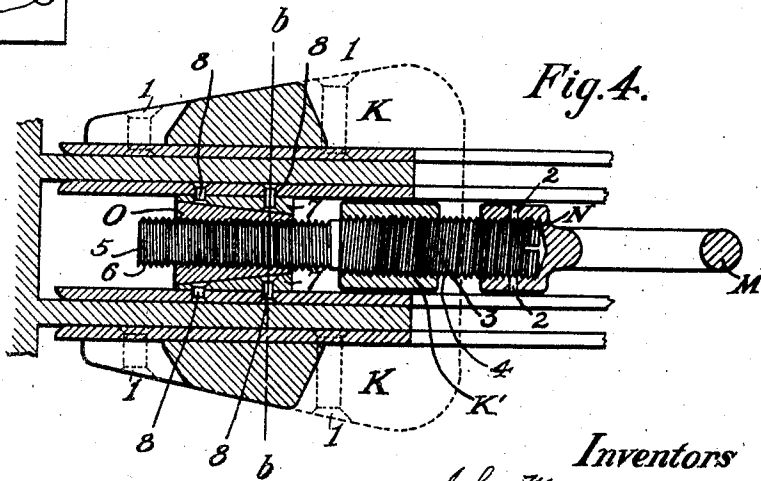

Fig. 4.

Witnesses.
 Harry Alexander
 Robert Knight Buzzell

Inventors
 John Morse
 Frederick Thomas Kaelin
 per Clarence Thomson
 Attorney

J. MORSE & F. T. KAELIN.
 ELECTRIC SWITCH.
 APPLICATION FILED JUNE 17, 1909.

Patented July 11, 1911

3 SHEETS-SHEET 3.

997,316.

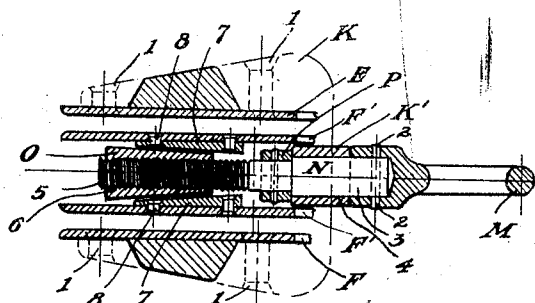

Fig. 6.

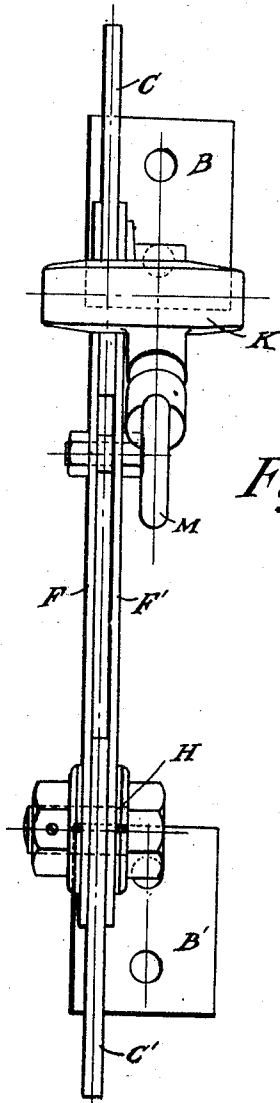

Fig. 7.

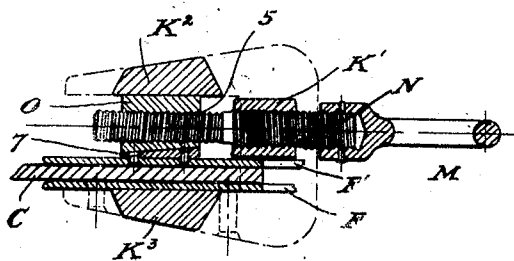

Fig. 8.

Witnesses

equal
 Fred. Thomson

Inventors
 John Morse
 Francis Thomas Kaelin
 by Clarence Thomson
 Attorney

UNITED STATES PATENT OFFICE.

JOHN MORSE AND FREDERICK THOMAS KAELIN, OF MONTREAL, QUEBEC, CANADA.

ELECTRIC SWITCH.

997,316.

Specification of Letters Patent.

Patented July 11, 1911.

Application filed June 17, 1909. Serial No. 502,769.

To all whom it may concern:

Be it known that we, JOHN MORSE, a subject of the Kingdom of Sweden, and FREDERICK THOMAS KAELIN, a citizen of the Republic of Switzerland, both residing at Montreal, in the Province of Quebec, in the Dominion of Canada, have invented certain new and useful Improvements in Electric Switches, of which we do declare the following to be a full, clear, and exact description, reference being had to the accompanying drawings, forming part of the specification.

Our present invention relates to an improved form of an electric switch of the class known as knife switches for use in particular on circuits carrying currents of large capacity where it is desirable to have a switch which will practically lock itself when placed in the closed position or at least do so with as little manipulation as possible by the operator when closing same and which will also render itself capable of being unlocked and opened with practically little extra manipulation and taking but a small portion of time over the amount of time taken to open an ordinary knife switch.

Another feature of our invention is that in the arrangement of the operating and locking means, the switch may be operated to be closed and locked in position without it being necessary for the operator to bring his hand or other portion of his body in close proximity to the contacts of the switch as is usually necessary in switches of this character.

The primary object of our invention consists in providing a switch which may be quickly locked in closing and unlocked in opening and this we obtain by arranging that the movable portion may be pivoted at one end and provided at its opposite end with such a construction that a slight turn of the handle in closing results in quickly securing a positive and locking contact of the blades and an equally quick releasing of the contacts when opening the switch by first giving the handle a correspondingly slight turn in the opposite direction. Once locked the contact cannot be broken except by the operation of the handle in this manner.

By the arrangement of the handle and the locking means as hereinafter shown and

the switch wherein it is not necessary for the operator to bring his hand or any portion of his body in close proximity to the contacts of the switch.

Our invention is illustrated in the accompanying drawings, in which—

Figure 1 is a perspective view in elevation of one form of switch. Fig. 2 is a front elevation and Fig. 3 is a side view of the same. Fig. 4 is a section on the line *a a*, Fig. 3. Fig. 5 is a section on the line *b b*, Fig. 4. Fig. 6 is a section on the line *a a*, Fig. 3 showing a modified construction. Fig. 7 is a front elevation of a modification of the switch shown in Fig. 2. Fig. 8 is a section in the line *a a* of Fig. 3, considering Fig. 3 as a side elevation of the modified form of switch illustrated in Fig. 7.

Referring to the form of switch shown in Figs. 1 to 5, on a base *A* of marble or other suitable insulating material a block of metal *B* is mounted and to this are secured the contact terminals *C C* which carry at their upper extremities the binding posts *D D* to which they are clamped by means of the bolts *E E*. The blades *C C* are arranged to be engaged by the blades *F F'* and *F' F* on the movable portion of the switch. These blades *F F'* and *F' F* are held firmly together by the bolts *G G* and at their lower ends are pivoted at *H H* and the several blades *F F'* and *F' F* are held in firm contact with corresponding stationary terminals *C' C'* which are held by a block of metal *B'* also supported on the base *A*. For the sake of clearness we have omitted the lower binding posts of the switch but these may be bolted to the terminals *C' C'* at *J J* in the same manner as the binding posts *D D* are shown bolted to the terminals *C C*.

The operating and locking means is shown in all the figures of the drawings but more fully in Figs. 3, 4, and 5, to which particular reference will now be made. The contact blades *C C* have been omitted from Fig. 5 for the sake of clearness. The crosspiece *K* is riveted to the contact blades *F* and *F'* at 1 1 and carries the operating handle *M* which is secured to the bolt *N* at 2 2. The bolt *N* passes through the outer portion *K'* of the crosspiece and engages at its inner end with the wedge *O*. Referring to Figs. 4 and 5, the outer portion 3 of the bolt is formed with a left-hand thread 4 which engages with a similar thread on the portion

of a smaller diameter and is formed with a right-hand thread 6 which engages with a similar thread in the wedge O. The outer surface of this wedge O engages with the wedge-shaped blocks 7 7 which are riveted at 8 8 8 8 to the inner blades F' F'. As a result of this construction, when the handle M is given a turning movement—in one form of our switch this amounts to a three-quarter turn—in the clockwise direction (Fig. 2) the bolt N moves outward to the right (Fig. 4) the wedge O is drawn up to the right in contact with the wedge-shaped blocks 7 7 and the blades F' F' are forced into firm contact with the terminals C C and as the blades F F are held firmly in position by the crosspiece K the terminals C C are tightly engaged between the blades F F' and F' F, respectively. As can readily be seen, this contact cannot be broken except by the operation of the handle in the opposite or counter-clockwise direction when, in opening, the bolt N moves to the left (Fig. 4) and forces the wedge O to move to the left and disengage itself from contact with the wedges 7 7, which permits of a freedom of movement between the terminals C C and the blades F F' and F' F and allows the switch to be opened.

The details of the above construction may be varied without departing from the spirit of our invention. For example, we show in Fig. 6 a modified construction in which the bolt N has formed upon it only one thread 6 which engages with a similar thread in the wedge O. There is no thread on the bolt at 4 where it passes through the crosspiece K, but the bolt N has a collar P secured to it in order that it may not move longitudinally on its axis, although it may turn on it. We, however, regard the construction shown in Figs. 1 to 5 as preferable, as we obtain a more rapid operation on the locking means.

In Figs. 7 and 8, we show a modification of our switch which consists of one pair only of stationary terminals having only one pair of contact blades operating between them. Some parts have been omitted for the sake of clearness, but C C' represent the pair of terminals having the contact blades F F' operating between them much in the same manner as in the switch shown in Fig. 2 except that the wedge O and the wedge shaped block 7 are arranged to act upon the outer face of one of the contact blades, in this case F'. As shown in Fig. 8, the bolt N passes through the wedge O which on one side engages with the wedge-shaped block 7 and on the other side with a portion K² of the crosspiece K. The bolt is shown threaded as in Fig. 4 where it passes through the portion K' of the crosspiece K and at 5 where it engages the wedge O. On giving the handle M a turning movement in the proper direction, the bolt N moves outward,

the wedge O is drawn up into contact with the inner face K² of the portion of the crosspiece K and the wedge-shaped block 7 and the contact blade F' is forced into close contact with the terminal C, the blade F being held in firm contact with the terminal C on the other side by means of the portion K³ of the crosspiece K.

Although we have shown in the drawings a switch having a ring-shaped handle, it will readily be understood that we do not wish to be confined to this particular shape of handle, as, of course, we may use the shape of handle of the ordinary knife switch. For such switches, however, as are to be used on high voltage circuits where it is desirable to operate the switch by means of a rod having a hook-shaped end, the operator can catch hold of the ring-shaped handle by means of the hook, and, by giving the rod a turn, readily obtain a releasing or locking of the contacts to open or close the switch.

Although we have shown our switch mounted on a base of insulating material, it will be readily understood that such a construction is not necessary as all the contacts may be mounted on separate insulating blocks or in any suitable manner according to the conditions governing the placing of the switch.

Having thus described our invention, what we claim as new and desire to secure by Letters Patent, is:—

1. In an electric switch, the combination with a pair of stationary contact terminals, of a movable member consisting of a pair of contact blades pivoted to one of said stationary contact terminals means for locking the movable member to one of the stationary contact terminals which consists of a crosspiece secured to the said movable member, a wedge, a bolt passing through said crosspiece having secured to its outer end a handle and having its inner end passing through said wedge, said bolt having a thread formed upon it to engage a similar thread in the crosspiece where the bolt passes through it and a thread of the opposite kind formed on it to engage with a similar thread in the wedge where the bolt passes through it and a wedge shaped block secured to the outer side of one of said contact blades whereby when the handle is operated the bolt actuates the wedge and wedge-shaped block to clamp the movable member and the stationary contact terminals, substantially as described.

2. In an electric switch, comprising two pairs of stationary contact terminals and a movable member consisting of two pairs of contact blades pivoted to one pair of said stationary contact terminals, means for locking the movable member to the stationary contact terminals which consists of a crosspiece secured to the said movable member, a wedge, a bolt passing through said cross-

piece having secured to its outer end a handle, and having its inner end passing through said wedge, said bolt having a thread formed upon it to engage a similar thread in the crosspiece where the bolt passes through it, and a thread of the opposite kind formed on it to engage a similar thread in the wedge where the bolt passes through it and wedge-shaped blocks secured to the two inner contact blades whereby when the

handle is operated the bolt actuates the wedge and wedge-shaped blocks to clamp the movable member and the stationary contact terminals, substantially as described.

JOHN MORSE.
FREDERICK THOMAS KAELIN.

Witnesses:
FRED. THOMSON,
EFFIE COLE.