

G. Hopson.

Making Springs.

N^o 100,630.

Patented Mar. 8, 1870.

Fig 2

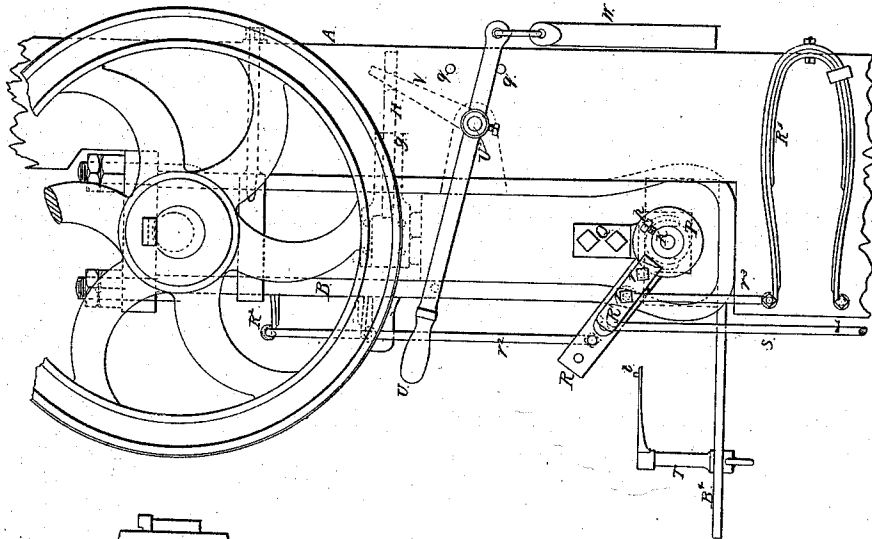
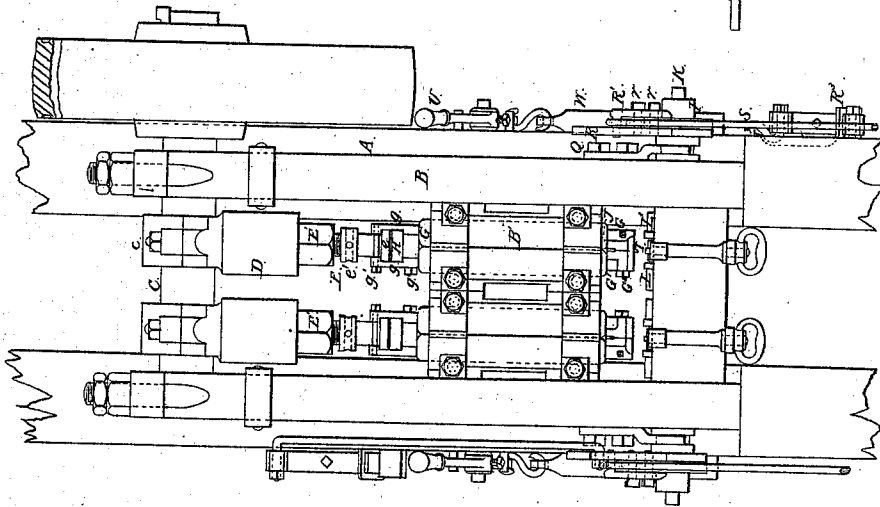

Fig 1



Witnesses:
L. B. Loring
M. C. Day

Inventor:
G. Hopson
by his attorney
J. D. Sutton

G. Hopson.

Making Springs.

N^o 100,630.

Patented Mar. 8, 1870.

Fig 3.

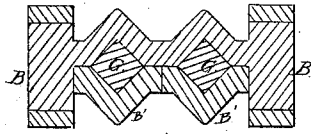

Fig 4.

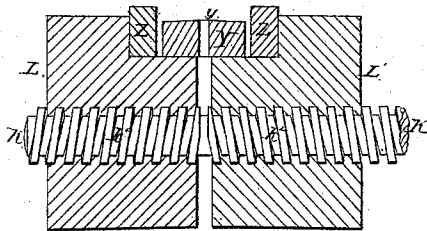

Fig 5.

Fig 6.

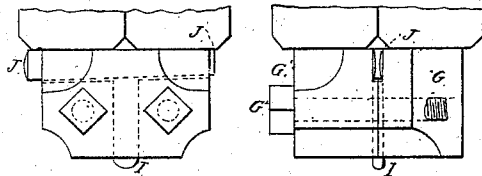
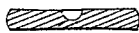

Fig 7.



Fig 8.



Witnesses:
J. C. Livingston
J. C. Day

Inventor:
G. Hopson
S. S. [Signature]

United States Patent Office.

GEORGE HOPSON, OF BRIDGEPORT, CONNECTICUT.

Letters Patent No. 100,630, dated March 8, 1870.

IMPROVED MACHINE FOR PUNCHING THE LEAVES OF ELLIPTIC SPRINGS.

The Schedule referred to in these Letters Patent and making part of the same.

To all whom it may concern:

Be it known that I, GEORGE HOPSON, of Bridgeport, in the county of Fairfield, and State of Connecticut, have invented certain new and useful Improvements in Machines for Manufacturing Elliptic and Analogous Springs; and I do hereby declare the following to be a full and exact description thereof.

My invention relates to the treatment of the leaves or plates, to indent the groove or blind-slat, as it is termed, and to raise the projection or bead, whereby the plates are matched together and kept in line while they slip endwise upon each other at their ends, in the act of being compressed or deflected and again extended or resuming their original position.

It has long been common to provide such groove and such projection, and to match them together; but my means for forming them are peculiar, and, in many points, are productive of very marked advantages.

I will first describe what I consider the best means of carrying out my invention, and will afterwards designate the points believed to be new, mentioning some of the more obvious advantages due to these novel features.

In the accompanying drawings which form part of this specification—

Figure 1 is a front elevation, and

Figure 2, a side elevation of the entire machine.

Figures 3 and 4 are sectional views of some of the principal parts, to be hereinafter referred to.

Figures 5 and 6 are different views, in elevation, of one of the punches set in its stock.

Figure 7 is a transverse section of a leaf of a spring, showing the bead as formed by my machine; and

Figure 8 is a transverse section of another leaf, formed with a "blind slot," to receive the bead on the leaf, fig. 7.

Similar letters of reference indicate corresponding parts in all the figures.

Tints are employed merely to aid in distinguishing parts, and do not imply differences of material.

Referring to the drawings—

A A represent side supports, made generally of wood, and constructed to receive a cast-iron frame, B B, which, with its attachments, is secured in place and rendered firm in the supports A A by means of connecting-straps and bolts. This and many other details of the machine will be readily understood by good mechanics, by the aid of the drawings, without special description.

In bearings fitted in the upper part of the sides of the frame B B is journaled a shaft, C, carrying a fly-wheel, and driven from an engine or other suitable motor.

D D are massive connections receiving motion from cranks or eccentrics *e* on the shaft C.

E E are screws of large diameter fitted in the lower ends of the connections D, each with a strong jambut to bear the strain.

Each of these screws has a flange, *e*, and a collar, *e'*, as shown in fig. 1. By taking hold of these collars by means of a suitable wrench, the screws E can be turned.

G G represent the slides which carry the punches for forming the blind slot and bead. These slides move in guides formed by a part of the frame B and binders B' B', as represented more clearly in fig. 3.

On top of each slide G is formed or attached a sort of box, *g g*, the sides of which are connected together by bolts *g' g'* on opposite sides of the screws E, above the flanges *e* of the latter, thus forming the connection between the slides G and rods D.

By taking hold of the collars *e'* on the screws E with a suitable wrench, the screws can be turned so as to lengthen or shorten the connection between the slides G and the drive-shaft, as may be desired.

Nearly the entire surface of each slide is available to serve as guiding-surface and as friction-surface, and the friction is made sufficient to hold up the weight of the slide and allow it to remain stationary in its highest position when the slide H is moved back.

H H are narrow slides fitted in the boxes *g g*, and connected, as shown in fig. 2, with arms V projecting from short shafts U, provided each with a lever, U, weighted as represented.

The movement of these levers is limited by pins *q q* on either side.

When the slides are in the position represented by dotted lines, fig. 2, in which position they are kept by the weights on the levers U, the connecting-rods D D will rise and fall as the shaft C rotates, without producing any motion of the slides G; but when the slides H H are moved forward in the boxes *g g*, which is effected by depressing the levers U, they fill the spaces between the bottoms of the boxes *g g* and the flanges *e e* of the screws, so that the reciprocating motion of the connections D is imparted to the slides G.

The lower portion of each slide G is formed with a recess in which a jaw marked G¹ is fitted and secured by means of the bolt G².

A recess is formed in the parts G G¹ for the reception of a punch, I, which is held within such recess.

J represents a key fitted into a key-way provided in the part G¹ at the upper part of the socket or recess which receives the punch I.

By adjusting this key, that is, driving it more or less into the opening made for it, the punch I is made to extend below the lower face of the jaw G¹ a greater or lesser distance, as desired, according to the depth to which the grooves or indentations in the hot plate or leaf are to be sunk.

In the lower part of the framing of the machine, immediately below the slides G, are placed two pairs of blocks which receive and hold the blanks to be impressed by the punches.

The blocks L L' of each pair are connected together by a screw, K, having right and left-hand threads k^1 k^2 , as shown in fig. 4. By means of these screws the blocks are made to approach or recede from each other according to the direction in which the screws are turned.

In practice, and by the intervention of mechanism to be hereinafter described, each screw K is turned alternately in opposite directions, and consequently the movements of the blocks L L' of each pair toward and from each other occur alternately and at short intervals, the extent of their movements being limited.

Y represents a die or bed-piece, resting in a recess in the tops of the blocks L L', and covering the space between them. On the upper surface of this die rests the blank during the operation of indenting it.

Z Z are blocks, arranged at the sides of the die Y and projecting above it, so as to form, in connection with the die, a depression, which receives and holds the blank, and preserves it against spreading laterally, or becoming in any way distorted under the operation of indenting. The die Y, if fixed at all, is made fast to only one of the blocks L L'.

It is, of course, understood that there are two dies Y, differing slightly in construction, as will be hereinafter described, one to each pair of blocks L L'.

Each screw K carries a collar, P, which fits loosely, and is provided with a set-screw, p , by means of which the collar can be fixed in position.

Q Q are metallic plates, bolted to the sides of the frame B, and forked so as to embrace the tubular portions of the collar P, annular grooves being formed in the latter for the purpose, as shown. This device prevents the longitudinal movement of the screws K, without interfering with their being turned.

The screws K are turned by the mechanism to be now described. Separate but similar sets of mechanism are employed for turning the two screws, and therefore only one set is here described.

R is a lever, fitted to turn upon the screw K, and having bolted to it a narrow plate, R', of metal, thus forming a friction-clutch, which receives the outer portion of the collar P, as clearly illustrated in the drawings.

R² R³ are springs, attached to the frame of the machine, and connected by means of rods, r^2 r^3 , respectively, with the clutch device R R'. These springs tend constantly to throw the clutch-lever R R' upward.

S is a rod, attached to the lever R, and connected with a treadle, (not represented,) which can be depressed at will by the direct pressure of the foot, or by the action of a brake and clutch, or other mechanism set in motion by means of the foot. The depression of the clutch-lever R R' on either side of the machine, turns the corresponding screw K, so as to draw the blocks L L', which it operates, toward each other; and the liberation of the treadle, and consequently of the lever R R', permits the immediate elevation of the said clutch-lever by the action of the springs R² R³, thus forcing the blocks L L' apart.

T T are stands, adjustable in long slots in arms B', which extend out from near the base of the frame-work B.

The tops of these stands are extended as represented, and are provided each with a pin, point, or projection, t . By means of these stands, which serve as gauges, the plates being operated upon are put in proper position to be indented.

The lower surfaces of the slide G and jaw G' are accurately finished; and these surfaces coming in contact with the face of the plate being treated, power-

fully compress the said plate, so as to prevent its distortion under the action of the punch.

It is common to produce the plates or leaves for elliptic or analogous springs with hollowed faces. In other words, the leaves when applied together fit closely at their edges, but are a little distance apart along the center of the upper and lower surfaces. This form of the leaves can be produced in my machine, by so shaping the upper surface of the die Y and the lower surface of the slide G and jaw G', that they are correspondingly rounded; and I so adjust the descent of the slides G as to exactly allow for the thickness of the steel, and powerfully compress the upper and lower faces of the hot-steel plate.

The blocks L L', or the facings Z, constituting, in effect, a part thereof, are so formed as to project above the upper surface of the die Y to a height about equal to the thickness of the thinnest steel. These projecting portions on the blocks serve to prevent the steel from being appreciably spread under the action of the punch.

The facings Z, shown in fig. 4, may be either formed with and of the same material as the blocks L L', or they may be separate. For instance, the main portions of the blocks L L' may be of soft iron, while the facings are hardened steel. I have so represented the blocks in the drawings, but I do not consider it essential to the success of my invention to give the blocks this improved construction.

When it is found necessary to adjust the blocks L L' to receive wider or narrower steel, the position of the screw K is changed, relatively to the lever R. This can be done in small adjustments by liberating the clamping-piece R', and then turning the screw K, together with the collar P, and then re-securing the lever R by retightening the clamping-piece R'.

As before stated, and as shown in the drawings, my machine is provided with two punches, I, differing from each other only in width, the wider one being employed to form the "blind-slot," which receives the bead on the next leaf, and the narrower punch being adapted to make the shorter indentation required to raise said bead.

The dies Y Y, which rest on the blocks L L', differ in construction in this respect: The one under the punch which forms the "blind-slot" has no depression in its upper surface, so that the formation of the "slot" by the punch simply increases the length or width of the steel, or both, to an inappreciable extent; while the die on the other side (where the bead is formed) is made with an opening, y , extending down through the die, into which opening the metal displaced by the punch above is directly forced and forms the bead.

I have given much attention to so forming the projecting portions of the punches I that the corresponding indentations in the steel shall be of such form as will weaken the plate the least, and have devised a mode of placing the "blind-slots" and beads in the leaves, so as to strengthen rather than weaken the spring. This arrangement of the grooves or "blind slots" and beads will be made the subject of another application; but the form of the punch is represented in figs. 5 and 6, from which it will be seen that a rounded outline is presented in every position, all angles being carefully avoided.

I will now mention certain modifications which may be made in my machine.

Instead of weighting the levers U to keep the slides H drawn out, as shown and described, flat springs may be so attached to the frame-work and to the slides H as to retain the latter in the position shown by dotted lines, fig. 2.

In place of the arrangement of springs, treadles, and connections hereinbefore described, for operating the levers R to turn the screws K, said levers may be de-

pressed by hand, and elevated by means of springs attached at one end to the lever, and at the other to some part of the frame.

The stands T may be dispensed with.

Having thus described my invention, with the means which I prefer for putting it into effect,

What I claim as new, and desire to secure by Letters Patent, is as follows:

1. The herein-described arrangement of the two punches I I in separate carriers, G G, inoperative except at will, and capable of operating in rapid succession, or simultaneously when desired, and adapted, the one for forming the blind slot, and the other for raising the bead, whereby each leaf or plate may be completely punched at a single heating, as set forth.

2. The parts *g g'* carried on the slide G, and the slide H or its equivalent, combined and arranged for operation relatively to each other and to the screw E, jamb-nut E', and collars *e* and *e'*, on the connection D, all substantially as and for the purpose herein set forth.

3. In connection with the above, the punch-carrier G and guiding-surfaces, formed by the binder B' and the frame, of the proportions relative to one another substantially as described and shown, for the purpose

of distributing the friction necessary to hold the carrier G in its place, over a greater extent of surface, as specified.

4. The within-described combination and arrangement of the jaw G', key J, punch I, and slide G, for the purposes herein set forth.

5. The blocks L L', carrying the die, and connected by means of the right and left-hand screw K, adapted to be turned substantially as described, when arranged as specified with relation to the heated metal and the punch, for the purposes herein set forth.

6. The combination of the lever R, clamp R' and bolt *r*, the flange P, screw K, and blocks L L', as specified, so that the blocks L L' can be adjusted to admit different widths of steel, holding the plate, of whatever width it may be, exactly central under the punch, and opening and closing a little by the action of the screw, as herein set forth.

In testimony whereof I have hereunto set my name in presence of two subscribing witnesses.

GEO. HOPSON.

Witnesses:

C. O. BULLOCK,
L. BULLOCK.