

(19) World Intellectual Property  
Organization  
International Bureau



(43) International Publication Date  
6 May 2004 (06.05.2004)

PCT

(10) International Publication Number  
**WO 2004/038865 A1**

- (51) International Patent Classification<sup>7</sup>: **H01R 13/56**
- (21) International Application Number:  
PCT/EP2003/050734
- (22) International Filing Date: 20 October 2003 (20.10.2003)
- (25) Filing Language: English
- (26) Publication Language: English
- (30) Priority Data:  
1021724 23 October 2002 (23.10.2002) NL
- (71) Applicant (for all designated States except US): FCI  
[FR/FR]; 53 rue de Châteaudun, F-75009 Paris (FR).
- (72) Inventor; and
- (75) Inventor/Applicant (for US only): DROESBEKE, Gert  
[BE/BE]; Pallo 15, B-2440 Geel (BE).
- (74) Agent: DE VRIES, Johannes, Hendrik, F.; De Vries &  
Metman, Overschiestraat 180, NL-1062 XK Amsterdam  
(NL).
- (81) Designated States (national): AE, AG, AL, AM, AT (utility model), AT, AU, AZ, BA, BB, BG, BR, BY, BZ, CA, CH, CN, CO, CR, CU, CZ (utility model), CZ, DE (utility model), DE, DK (utility model), DK, DM, DZ, EC, EE (utility model), EE, EG, ES, FI (utility model), FI, GB, GD, GE, GH, GM, HR, HU, ID, IL, IN, IS, JP, KE, KG, KP, KR, KZ, LC, LK, LR, LS, LT, LU, LV, MA, MD, MG, MK, MN, MW, MX, MZ, NI, NO, NZ, OM, PG, PH, PL, PT, RO, RU, SC, SD, SE, SG, SK (utility model), SK, SL, SY, TJ, TM, TN, TR, TT, TZ, UA, UG, US, UZ, VC, VN, YU, ZA, ZM, ZW.
- (84) Designated States (regional): ARIPO patent (GH, GM, KE, LS, MW, MZ, SD, SL, SZ, TZ, UG, ZM, ZW), Eurasian patent (AM, AZ, BY, KG, KZ, MD, RU, TJ, TM), European patent (AT, BE, BG, CH, CY, CZ, DE, DK, EE, ES, FI, FR, GB, GR, HU, IE, IT, LU, MC, NL, PT, RO, SE, SI, SK, TR), OAPI patent (BF, BJ, CF, CG, CI, CM, GA, GN, GQ, GW, ML, MR, NE, SN, TD, TG).
- Published:  
— with international search report
- For two-letter codes and other abbreviations, refer to the "Guidance Notes on Codes and Abbreviations" appearing at the beginning of each regular issue of the PCT Gazette.

(54) Title: CABLE CONNECTOR ASSEMBLY AND SYSTEM

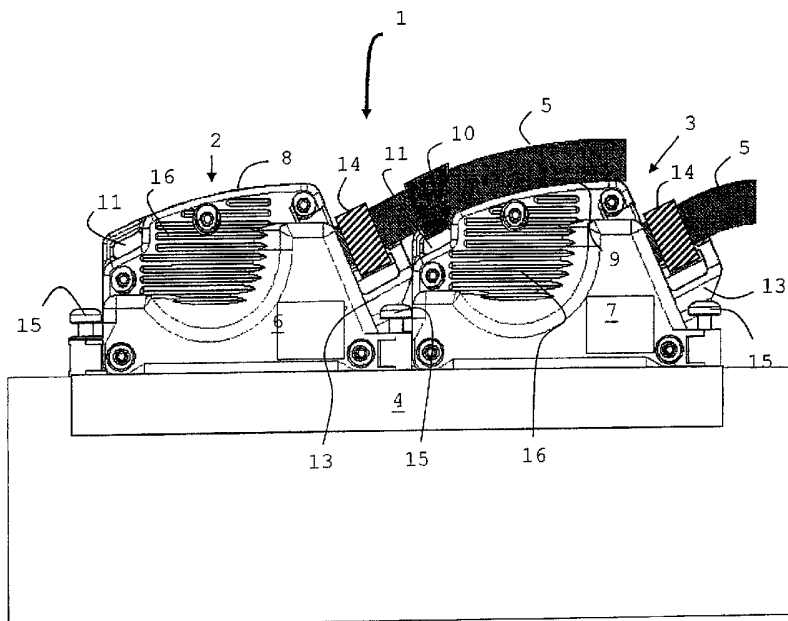

(57) Abstract: The invention relates to a cable connector assembly comprising cover means and connecting means, wherein the cover means comprise wall portions and an opening adapted to accommodate the connecting means. At least one of the wall portions is at least partially curved for guiding at least one cable of one or more other cable connector assemblies. Cable ties to attach the cable to the curved wall portion are disclosed as well. The invention facilitates cable management in dense and small cabinets.

WO 2004/038865 A1

## Cable connector assembly and system

The invention relates to a cable connector assembly comprising cover means and connecting means, said cover means comprising wall portions and an opening adapted to accommodate said connecting means.

WO 99/27616 discloses a high density electrical connector system, wherein the electrical connectors have a hood with a sloping top. Because of the slope of the hood and the position of the opening in the hood for a cable, a second connector does not interfere with this cable.

It is an object of the invention to provide a cable connector assembly and a connector system wherein cable management is facilitated. This is important since the cabinets containing the cables are getting smaller and the density of cable connector assemblies on a circuit board increases.

This object is achieved by providing a cable connector assembly characterized in that at least one of said wall portions is at least partially curved for guiding at least one cable of at least one other cable connector. By adapting the cover means such that it allows guiding cables of other cable connector assemblies, these cables can be controlled by the cover means. The curvature of the wall portion can be close to the minimum bend radius at which a signal through the guided cable or the shielding of the cable starts to degrade. For the shielding of the cable, especially the braid is susceptible for bend forces if the bend radius of the cable becomes too small.

In an embodiment of the invention the cover means of the cable connector has means for reducing the movement of a cable over the cover means. Preferably these means include cable tie means for attaching the cable to the partially curved wall portion to secure the guided cable. Alternatively or in addition the curved wall portion may be curved substantially perpendicular to a longitudinal axis of the curved wall portion. This is e.g. advantageous if a single cable is to be guided over the curved wall portion. Moreover other structures or material compositions for the wall portion can be envisaged that are adapted to reduce the movement of the cable.

can be envisaged that are adapted to reduce the movement of the cable.

The invention also relates to a cable connector system comprising at least a first and a second cable connector assembly according to any one of the preceding claims, wherein said first cable connector comprises said at least partially curved wall portion and said second cable connector comprises a wall portion having an opening adapted for directing said cable substantially tangential to said at least partially curved wall portion. By adapting the opening the cable connectors can be positioned in close proximity to each other, thereby providing the possibility to obtain a high density system of cable connectors on e.g. a circuit board with improved cable management features. The system may comprise several cable connector assemblies, wherein the cover means of the assemblies guide at least some of the cable of these cable connector assemblies. These cables can be attached to the cover means by cable tie means. In this way a flexible cable management system is obtained.

The invention also relates to the cover means as such, comprising an at least partially curved wall portion.

The invention will be further illustrated with reference to the attached drawing, which shows a preferred embodiment according to the invention. It will be understood that the cable connector assembly and system according to the invention are not in any way restricted to this specific and preferred embodiment.

Fig. 1 shows a cable connector system according to an embodiment of the invention;

Fig. 2 shows a perspective view of a cable connector assembly according to a first embodiment of the invention.

Fig. 3 shows different cable clamp arrangements;

Figs. 4A and 4B show perspective views of two parts of a cover according to a second embodiment of the invention;

Figs. 5A and 5B show perspective views of a cable connector assembly according to a second embodiment of the invention;

Fig. 1 shows a cable connector system 1 comprising a first cable connector assembly 2 and a second cable connector assembly 3 on a printed circuit board 4. Each of said assemblies 2, 3 has a cable 5 extending from said assemblies 2, 3. In Fig. 1 only the cover means 6, 7 of respectively the assemblies 2 and 3 are visible. It is noted that cover 6 and 7 may be identical or similar. The cover means 6, 7, hereinafter also referred to as cover, comprises upper wall portions 8, 9 that are curved for guiding the cable 5. The curvature of the upper wall is preferably close to the minimum bend radius of the cable 5. As a general rule the bend radius of the curved wall portion 8, 9 is equal to or higher than five times the outer diameter of the cable. For instance, in a cable connector system 1 with three types of cables 5 with outer diameters of 5, 6.5 and 10 mm, the curvature of the wall portions 8, 9 of the cover means 6, 7 is adapted to the cable 5 with the largest diameter, i.e. the curvature of the wall portions 8, 9 is at least 50 mm.

The cable 5 is reduced in movement and assisted in guidance by the cable tie 10 that attaches cable 5. This cable tie 10 may e.g. be of plastic material and can be adapted to easily fasten and release a cable. Alternatively the cable tie 10 may be a metal or plastic cable clamp. The cable tie 10 may be integrated with the cover means 6, 7. Cable tie 10 may attach several cables 5 from other connector assemblies (not shown) as well. The covers 6, 7 comprise a recess or slot 11 for holding the cable tie 10. It is noted that the recess 11 for the cable tie 10 is not necessarily located near the position on the upper wall where the cable approaches the assembly, but may e.g. be located in the middle of the upper wall 8, 9. Also more than one cable tie 10 can be applied.

The assemblies 2, 3 further comprise cable openings 12 (see Fig. 2) that are e.g. adapted by the alignment part 13 to direct the cable 5 of assembly 2 tangential to the curved wall portion 9 of the assembly 3. To facilitate this alignment an alignment part 13 may have a direction which gives cable 5 a direction which is just below the tangential direction such that contact with the upper wall 9 is ensured. Alignment parts

13 and the tie-wraps 14 may also have a bend relief function in Fig. 1. Alignment part 13 may be an integral part of the cover 6, 7 as well as being a mountable part. The upper wall 9 may comprise a small linear part near the location where the cable 5 meets the cover 7 to define the tangential direction for the cable 5. The cables 5 can be attached to the covers 6, 7 by the tie wrap 14. The assemblies 2, 3 are fastened to the printed circuit board 4 with screws 15. Covers 6 and 7 are provided with indents 16 for fingers to facilitate unmating of the connector assemblies 2, 3 from the headers (not shown) of the printed circuit board 4.

The construction of a cable connector assembly 2, 3 according to two embodiments of the invention will be discussed next in greater detail.

Fig. 2 shows a perspective view of the connector assembly 2 wherein the front part of the cover 6 is removed. Cover 6 comprises sidewall portions 20, 21 and 22 that together with the front part side wall 23 (see Fig. 4B) of the cover determine an opening 24 opposite to the partially curved upper wall 8, which opening 24 accommodates connecting means or terminal blocks 25 to be mounted on the printed circuit board 4. The front part of the cover 6 can be attached to the assembly 2 by using pins 26. Cable opening 12 may comprise a cable clamp 27 inserted in a slot of the cover 6 for strain relief of the cable 5. A connector assembly 2 may have several cables 5, possibly of different diameters, connected to the terminal blocks 25. Therefore different cable clamps 27', 27'' can be used, as shown in Fig. 3. The several cables 5 may all be guided by the upper wall 9 of cable assembly 3 or, alternatively, some of the cables 5 leaving cable assembly 2 are guided by the upper wall 9.

Figs. 4A and 4B show perspective views of two parts 30 and 31 that are to be attached to each other to form a cover 6. Similar or equivalent parts of the covers with respect to the first embodiment have been assigned identical reference numbers. The alignment part 13 at the cable opening 12 shown in Fig. 2 is omitted in the second embodiment. Instead the sidewalls 21, 23 of the cover 6 comprise a structure 32

forming a tubular cable opening 12 when the sidewalls 21 and 23 are attached to each other by fitting the pins 26 in corresponding holes 33. This tubular cable opening is adapted to perform the same function as the alignment part 13 in Fig. 2.

In Fig. 5A the cable assembly 2 is shown comprising a cable 5 in the tubular cable opening 12 formed by the structure 32 in the sidewall 21 of the cover 6. Cable 5 comprises a plurality of wires 34 that are to be connected to the appropriate terminal blocks 25. The cable 5 can be attached to the cover 6 in the tubular cable opening 12 by one or more components 35 for fixation of the cable to the cover 6. Such a component 35 may be a wrap that can be shrunk around the cable 5 and fitted in the tubular opening 12. Component 35 has a similar function as the cable clamps 27, 27', 27" as shown in Fig. 3. In Fig. 5B the connector assembly 2 is shown with the sidewall 23 in place, ready to be mounted to a printed circuit board 4. When mounted cable 5 can be guided by the upper walls of other similar connector assemblies, such as connector assembly 3. In this way management of the cables is improved.

It is noted that the cable or cables 5 of the connector assemblies 2, 3 are not necessarily in contact with the entire upper wall 8, 9. Especially at the end of the curved upper wall, the cable 5 may diverge from the upper wall since e.g. the destination of the cable 5 urges this cable to a particular direction.

Moreover it is noted that alternatively or in addition to the cable tie 10, other means for reducing movement and/or assisting the guidance of the cable 5 can be applied on the upper wall 8, 9. E.g. the upper wall 8, 9 may comprise a groove or further curvature in the longitudinal direction of the upper wall 8, 9. Further, structures or material compositions of or on top of the upper wall 8, 9 that are able to exert a sufficient friction force to the cable 5 when moved can be envisaged as well.

**Claims**

1. Cable connector assembly comprising cover means and connecting means, said cover means comprising wall portions and an opening adapted to accommodate said connecting means **characterized in that**

at least one of said wall portions is at least partially curved for guiding at least one cable of one or more other cable connector assemblies.

2. Cable connector assembly according to claim 1, wherein said wall portions comprise sidewalls determining said opening and an upper wall opposite to said opening which is at least partially curved for guiding at least one cable of one or more other cable connector assemblies.

3. Cable connector assembly according to claim 1 or 2, wherein said at least partially curved wall portion comprises means for reducing movement and/or assisting guidance of said cable.

4. Cable connector assembly according to claim 3, wherein said means comprises cable tie means for attaching said cable to said at least partially curved wall portion.

5. Cable connector assembly according to claim 4, wherein said cover means comprises means for holding said cable tie means, such as a recess, slot or pin.

6. Cable connector assembly according to claim 3, wherein said means comprises a further curvature of said wall portion substantially perpendicular to a longitudinal axis of said at least partially curved wall portion.

7. Cable connector system comprising at least a first and a second cable connector assembly according to any one of the preceding claims, wherein said first cable connector comprises said at least partially curved wall portion and said second cable connector comprises a wall portion having a cable opening adapted for directing said cable substantially tangential to said at least partially curved wall portion.

8. Cable connector system according to claim 6, wherein said system comprises further cable connector assemblies having further cables, said at least partially

curved wall portion of said first connector assembly guiding at least some of said further cables.

9. Cable connector system according to claim 8, wherein said first cable assembly comprises cable tie means for attaching said further cables to said at least partially curved wall portion.

10. Cover means comprising an at least partially curved wall portion according to any one of the preceding claims.

1/4

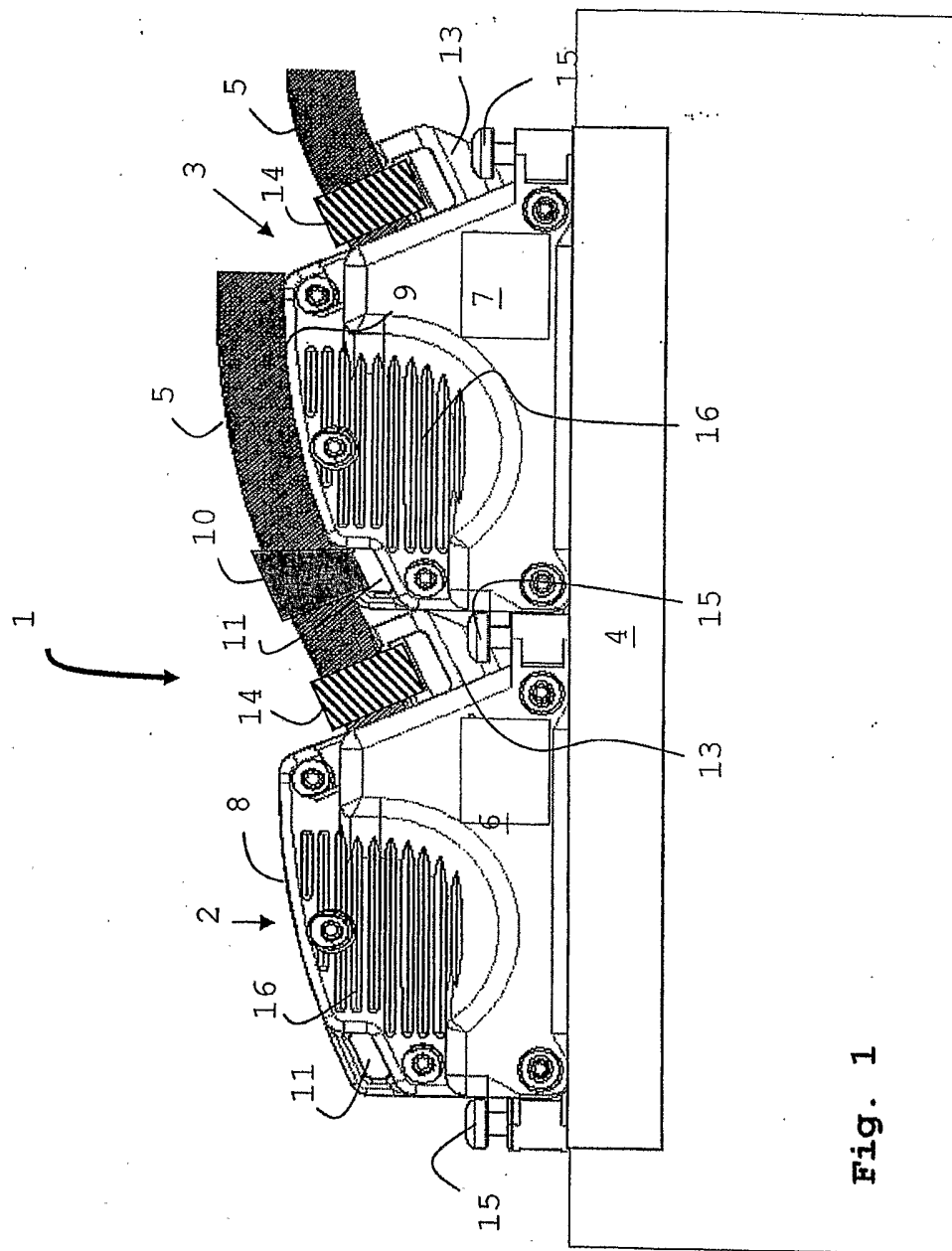

Fig. 1

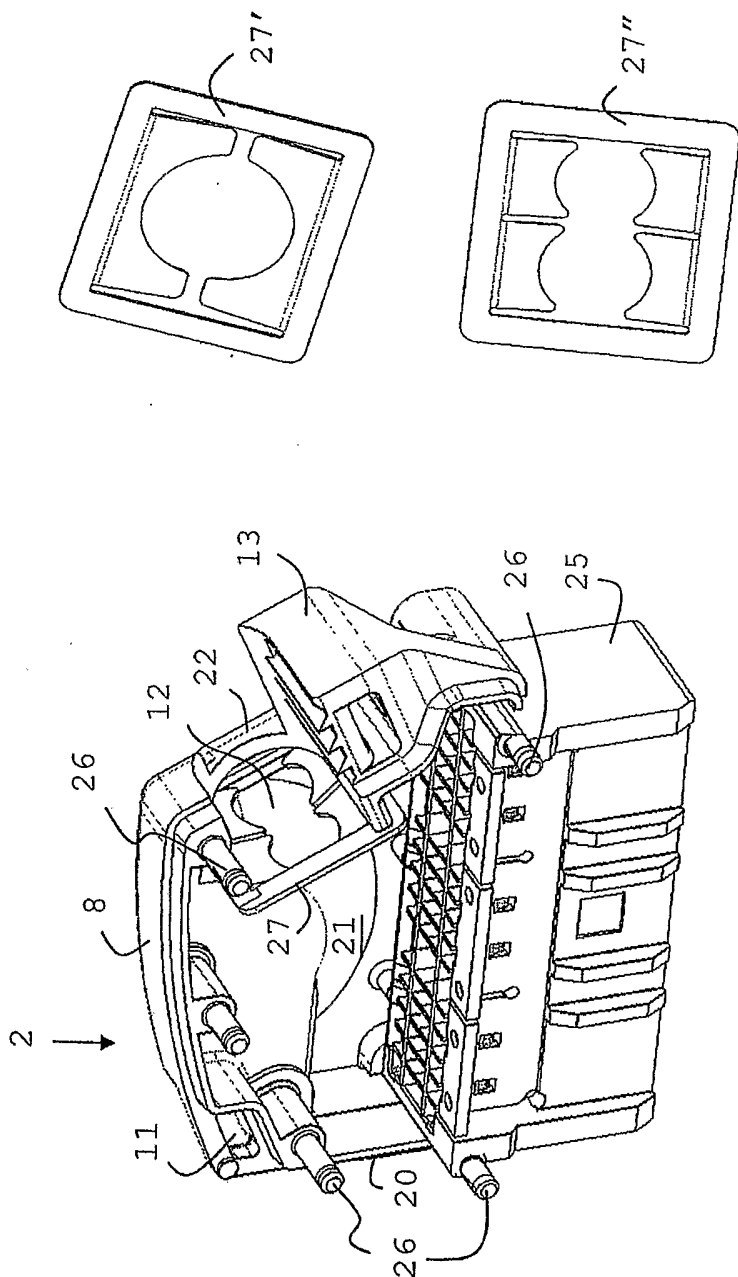

Fig. 3

Fig. 2

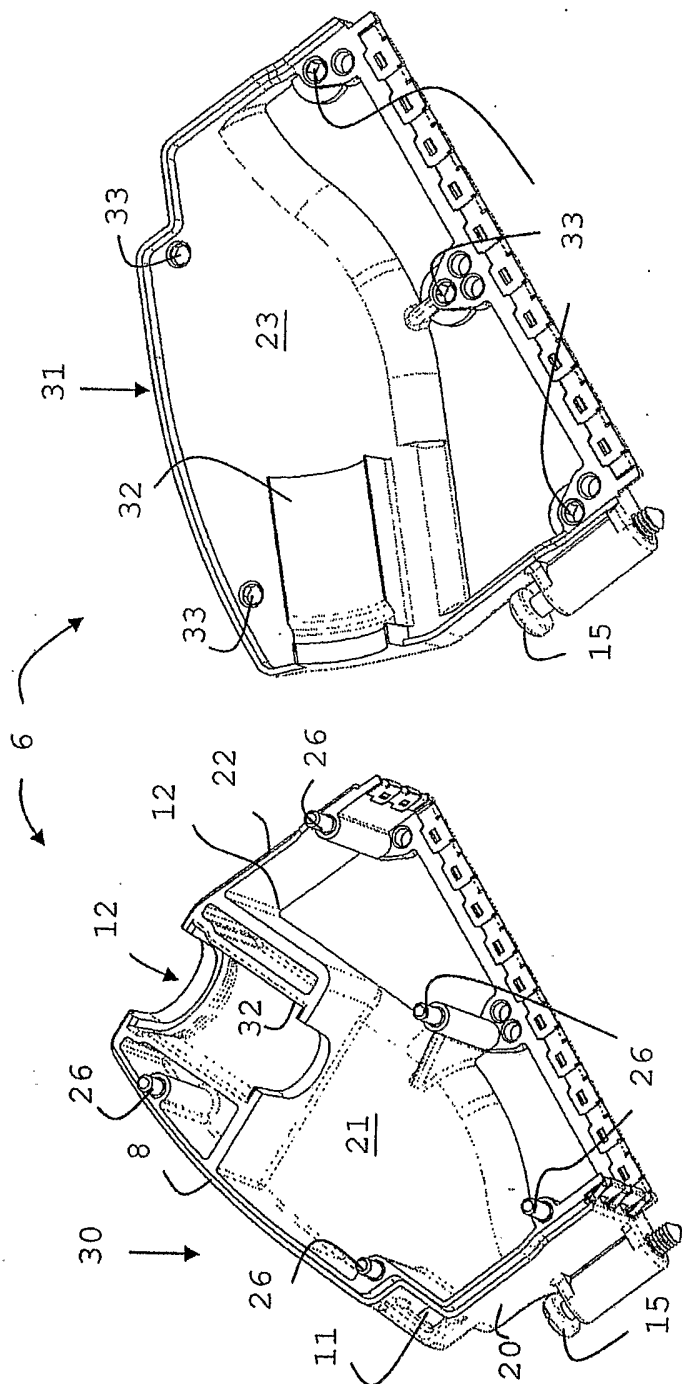

Fig. 4B

Fig. 4A

4/4

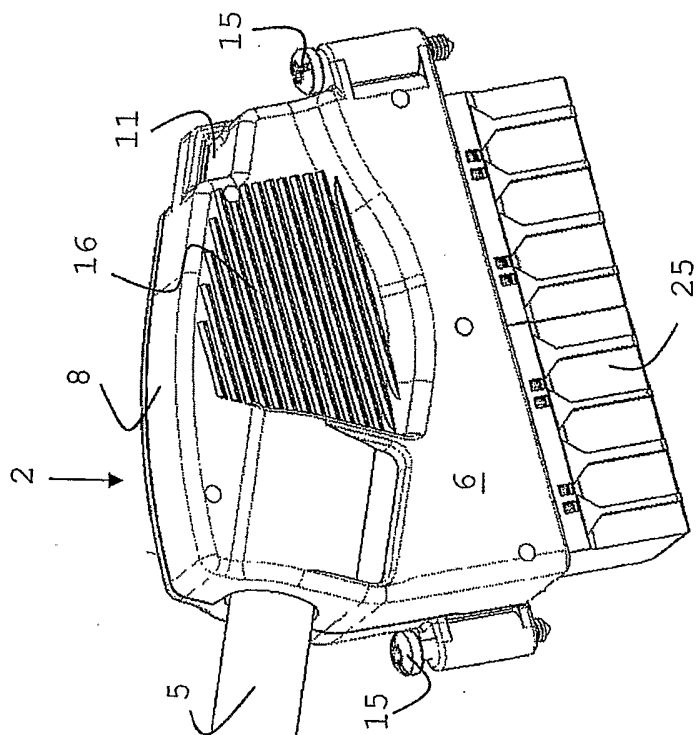

Fig. 5B

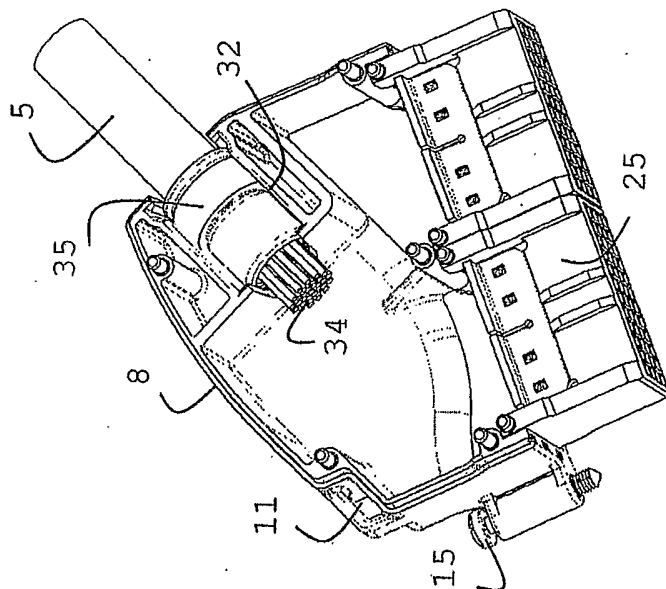

Fig. 5A

INTERNATIONAL SEARCH REPORT

International Application No

PCT/EP 03/50734

A. CLASSIFICATION OF SUBJECT MATTER  
IPC 7 H01R13/56

According to International Patent Classification (IPC) or to both national classification and IPC

B. FIELDS SEARCHED

Minimum documentation searched (classification system followed by classification symbols)  
IPC 7 H01R

Documentation searched other than minimum documentation to the extent that such documents are included in the fields searched

Electronic data base consulted during the international search (name of data base and, where practical, search terms used)

EPO-Internal, WPI Data, PAJ

C. DOCUMENTS CONSIDERED TO BE RELEVANT

Category *	Citation of document, with indication, where appropriate, of the relevant passages	Relevant to claim No.
X	EP 1 126 556 A (SUMITOMO WIRING SYSTEMS) 22 August 2001 (2001-08-22) column 2, line 28 - line 30; figure 9	1-10
A	WO 99 27616 A (SUPERIOR MODULAR PROD INC) 3 June 1999 (1999-06-03) cited in the application the whole document	1-10
A	EP 0 711 007 A (KRONE AG) 8 May 1996 (1996-05-08) abstract	1
A	DE 88 09 577 U (HTS GMBH) 15 September 1988 (1988-09-15) figures 2,3	1
	-/--	

Further documents are listed in the continuation of box C.

Patent family members are listed in annex.

\* Special categories of cited documents :

- \*A\* document defining the general state of the art which is not considered to be of particular relevance
- \*E\* earlier document but published on or after the international filing date
- \*L\* document which may throw doubts on priority claim(s) or which is cited to establish the publication date of another citation or other special reason (as specified)
- \*O\* document referring to an oral disclosure, use, exhibition or other means
- \*P\* document published prior to the international filing date but later than the priority date claimed

- \*T\* later document published after the international filing date or priority date and not in conflict with the application but cited to understand the principle or theory underlying the invention
- \*X\* document of particular relevance; the claimed invention cannot be considered novel or cannot be considered to involve an inventive step when the document is taken alone
- \*Y\* document of particular relevance; the claimed invention cannot be considered to involve an inventive step when the document is combined with one or more other such documents, such combination being obvious to a person skilled in the art.
- \*&\* document member of the same patent family

Date of the actual completion of the international search

Date of mailing of the international search report

4 February 2004

12/02/2004

Name and mailing address of the ISA

European Patent Office, P.B. 5818 Patentlaan 2  
NL - 2280 HV Rijswijk  
Tel. (+31-70) 340-2040, Tx. 31 651 epo nl,  
Fax: (+31-70) 340-3016

Authorized officer

Demo1, S

INTERNATIONAL SEARCH REPORT

International Application No

PCT/EP 03/50734

C.(Continuation) DOCUMENTS CONSIDERED TO BE RELEVANT

Category °	Citation of document, with indication, where appropriate, of the relevant passages	Relevant to claim No.
A	JP 11 040239 A (OKI ELECTRIC IND CO LTD) 12 February 1999 (1999-02-12) figures 1-12 -----	1

**INTERNATIONAL SEARCH REPORT**

Information on patent family members

International Application No

PCT/EP 03/50734

Patent document cited in search report		Publication date	Patent family member(s)	Publication date
EP 1126556	A	22-08-2001	JP 2001185283 A	06-07-2001
			EP 1126556 A2	22-08-2001
			US 2001016451 A1	23-08-2001
WO 9927616	A	03-06-1999	DE 19882832 T0	22-02-2001
			GB 2346271 A ,B	02-08-2000
			WO 9927616 A1	03-06-1999
			US 2001005652 A1	28-06-2001
EP 0711007	A	08-05-1996	DE 9418157 U1	09-02-1995
			AU 1788795 A	09-05-1996
			BR 9505026 A	14-10-1997
			EP 0711007 A2	08-05-1996
			NO 951738 A	02-05-1996
DE 8809577	U	15-09-1988	DE 8809577 U1	15-09-1988
JP 11040239	A	12-02-1999	NONE	