

⑫

**EUROPEAN PATENT SPECIFICATION**

- ④⑤ Date of publication of patent specification: **24.05.89**      ⑤① Int. Cl.<sup>4</sup>: **B 41 J 3/04**  
②① Application number: **86200146.8**  
②② Date of filing: **19.07.82**  
⑥⑧ Publication number of the earlier application in accordance with Art. 76 EPC: **0 072 110**

⑤④ **Ink jet dot printing head.**

③⑥ Priority: **04.08.81 IT 6809381**

④③ Date of publication of application:  
**25.06.86 Bulletin 86/26**

④⑤ Publication of the grant of the patent:  
**24.05.89 Bulletin 89/21**

③④ Designated Contracting States:  
**DE FR GB**

⑤⑧ References cited:  
**FR-A-2 325 510**  
**US-A-3 832 579**  
**US-A-4 025 928**  
**US-A-4 032 929**

**PATENT ABSTRACTS OF JAPAN, vol. 4, no. 179**  
**(M-46)661r, 11th December 1980**  
**PATENT ABSTRACTS OF JAPAN, vol. 5, no. 119**  
**(M-81)791r, 31st July 1981**

⑦⑧ Proprietor: **Ing. C. Olivetti & C., S.p.A.**  
**Via G. Jervis 77**  
**I-10015 Ivrea (Turin) (IT)**

⑦② Inventor: **Dagna, Giandomenico**  
**via S. Nazario 20**  
**I-10015 Ivrea (IT)**  
Inventor: **Manini, Enrico**  
**Frazione Bonaro 2**  
**I-13050 Camandona (IT)**  
Inventor: **Tadini, Giorgio**  
**C.so G. Pascoli 7**  
**I-10134 Torino (IT)**

⑦④ Representative: **Pears, David Ashley et al**  
**REDDIE & GROSE 16 Theobalds Road**  
**London WC1X 8PL (GB)**

Note: Within nine months from the publication of the mention of the grant of the European patent, any person may give notice to the European Patent Office of opposition to the European patent granted. Notice of opposition shall be filed in a written reasoned statement. It shall not be deemed to have been filed until the opposition fee has been paid. (Art. 99(1) European patent convention).

**EP 0 185 652 B1**

## Description

The present invention relates to an ink jet printing head according to the introductory part of claim 1.

This application is a divisional application divided from European Patent Application No. 82 303776.7, Publication No. 0 072 110. An ink jet printing head, as mentioned above but with a single nozzle, is known from U.S. 3,832,579, in which the ejecting tube is connected to an ink reservoir through a flexible tube of predetermined length, to eliminate reflection phenomena in the ejecting tube. The suggested length of the flexible tube is 10 cm, and so the tube occupies considerable space. This problem would be worse in a head having a plurality of ink ejecting tubes and a corresponding plurality of ink conducting tubes.

Another ink jet printer, with a single ink ejecting tube, is known from U.S. 4,025,928. The single ink ejecting tube is fixed into a cylindrical chamber filled with the ink. An elastic conduit is connected at one end to the ejecting tube and is helically coiled around the ejecting tube from near the top of the chamber down to the chamber bottom, so that the other open end of the conduit can deliver all the ink to the ejecting tube. A pair of U-shaped resilient bands are provided in the chamber to bias the coiled conduit against the walls of the chamber, whereby the helical conduit requires a relatively large space around the ejecting tube. This arrangement is thus unadapted for a compact multi-nozzle printing head.

The object of the invention is to provide a compact, multi-nozzle ink jet printing head which reduces the problem of excessive space being occupied by the flexible tube connecting each ejecting tube to the ink tank. The printing head according to the present invention is characterized in the manner set forth in claim 1.

One embodiment of the invention will now be described in more detail, by way of example, with reference to the accompanying drawings, in which:

Fig. 1 is a diagrammatic perspective view of an ink jet dot printer according to the invention;

Fig. 2 is a plan view, partly in section, of a head used on the printer of Fig. 1;

Fig. 3 is a side view, partly in section of the head of Fig. 2;

Fig. 4 is a front view, partly in section, of the head of Fig. 2;

Fig. 5 is a block diagram of a driving logic circuit of the printer of Fig. 1;

Fig. 6 is a diagrammatic representation of the printing process obtained with the circuit of Fig. 5;

Figure 7 is a partial section of a modified form of the head of Fig. 2.

Referring to Fig. 1, the printer S comprises a head 1 mounted on a carriage 10 moved along guides 12 by an electric motor 13 by means of a cable 14. The head 1 is formed by a rigid structure 2 (Figs 2 and 3) consisting of a front plate 3 and a

rear plate 5 which are parallel to one another and kept spaced apart by two side members 7, 9.

The head 1 can print in both directions along a printing line L (Fig. 1) on a carrier 15 passed around a platen 16. A synchronizing device 17 of known type, constituted, for example, by a strobe disc 18, keyed on the shaft of the motor 13, and a photoelectric transducer 20, is used to generate strobe signals for synchronizing the printing with the movement of the head.

More particularly, as is known, the timing device 17 generates the clock signals as a function of the position of the head along the printing line L and, therefore, the clock signals are independent of the speed of the head itself. By way of example, it is assumed that the synchronizing device 17 generates forty-two clock pulses while the head 1 shifts by a distance equal to the pitch  $p$  (Fig. 4) between two adjacent nozzles.

In each of the plates 3 and 5 there is formed a row of holes 22, for example twenty holes, which is inclined with respect to the direction of the movement of the carriage 10, each hole in the plate 3 being aligned with the corresponding hole in the plate 5. The holes 22 are equidistant by the pitch " $p$ ", measured in the direction of the movement of the carriage 10. Into each pair of corresponding holes 22 there are now introduced cylindrical tubes 24 adapted to contain ink which is to be expelled in the form of drops by a known technique, as will be described hereinafter. All the tubes 24 lie in a plane having the course  $F'-F'$  indicated by a chain-dotted line in Fig. 4 and the inclination of which is such that the distance between the first and the last hole of the row, measured perpendicularly to the direction of the movement of the carriage 10, is equal to the maximum height of the characters printed on the paper 15. The tubes 24 are firmly fixed in the holes 22 of the plates 3 and 5 by cementing with a resin, for example an epoxy resin, in such manner that the front end 26 thereof is positioned level with the outer surface 27 of the plate 3.

The tubes 24 project from the rear plate 5 by a certain length to permit their connection by means of the tubes 30 to an auxiliary ink reservoir 31 connected in turn by means of a flexible tube 32 to a main reservoir not illustrated in the drawings. The auxiliary reservoir 31 is fixed at the rear of the carriage 10 on a wall 33 of a parallelepipedal container 34 for protecting the tubes 30.

Inside the container 34, the tubes 30, which are of flexible material, are supported by a cylindrical drum 130 fixed to the side walls 132 of the container 34 by means of a shaft 133 coaxial with the drum 130. Each flexible tube 30 is wound around the outer surface of the drum 130 for one and a half turns, inasmuch as it begins and ends, respectively, in two diametrically opposite positions with respect to the drum 30.

Moreover, for the purpose of minimizing the space occupied by the tubes 30 in the axial direction on the drum 130, the flexible tubes 30 are wound around it alternately in opposite direc-

tions, whereby each half turn of the winding coil left free by one of the tubes 30 is occupied by the first half turn of the adjacent tube.

In this way, for each pair of tubes 30 only three turns are used on the drum 130, occupying, that is, a space in the axial direction equal to three diameters of the tubes 30, so that a total of thirty turns are necessary in all for the twenty tubes 30.

In addition to optimizing the utilization of the space in the container 34, this arrangement of the tubes 30 serves to prevent knocks between the tubes 30 caused by the forces of inertia generated by the movement of the carriage 10 (Fig. 1) at the stops and starts of the carriage.

The tubes 24 may be of chemically inert material such as, for example, glass or ceramic, but they may also be of metal, for example stainless steel or nickel. On the tubes 24 (Fig. 3), piezoelectric transducers 36 in the form of sleeves are cemented approximately half way along the tubes, the transducers being adapted to contract radially under the effect of an electric voltage pulse applied to them.

To this end, the inner and outer surfaces of the sleeves 36 are covered by two electrodes 37 and 38, respectively, the electrode 37 being brought over onto the outer surface of the sleeve to facilitate electrical connection. A printed circuit board 40 is located between the plates 3 and 5 and is traversed by the sleeves 36. The electrodes 37 and 38 are soldered to corresponding tracks 43 and 44 lying on the faces 45 and 46, respectively, of the board 40 (Fig. 4). The plate 40 projects at the bottom from the head (Figs. 3, 4) to permit electrical connection by means of a connector not shown in the drawings.

Inside the structure 2 there is cast a resin polymerizable at room temperature and of low shrinkage, for example an epoxy resin, to form a single block 48 enclosing all the tubes 24 and the corresponding sleeves 36.

When hardening has taken place, the block of resin 48 establishes a rigid and continuous connection between the plates 3 and 5, preventing the vibrations of each tube being transmitted through the plates to the adjacent tubes. Moreover, the block of resin 48 constitutes a reliable protection for the extremely fragile tubes 24 against possible knocks or shocks.

Mounted removably against the outer face 27 of the front plate 3 by means of screws 50 is a lamina 51 with a thickness less than that of the plate 3 and in which there are formed twenty nozzles  $U_0$  ...  $U_{19}$ , each of which is disposed in perfect alignment with respect to the corresponding tube 24. The alignment of the nozzles U with the respective tubes 24 is ensured by locating pins 52 fixed to the plate 3 and engaged in holes 53 in the lamina 51. In this way, the lamina 51 can be separated easily from the plate 3 to permit cleaning of the nozzles in the event of any of them becoming blocked because of drying of the printing ink. Each nozzle U is formed by an orifice 54 of cylindrical form of a diameter between 50 and 90  $\mu\text{m}$ , and a conically flared portion 56 connecting

the orifice 54 with the inner diameter of the tubes 24, which is of the order of 0.8 mm.

As already mentioned before, a drop of ink can be expelled from each nozzle U by the effect of the compression exerted by the corresponding transducer 36 when energized by a voltage pulse. All the transducers 36 are electrically connected through the medium of the printed circuit board 40 and a 20-wire cable 45 indicated diagrammatically in Fig. 1 to an energizing unit 58 of known type and not described in detail, which is able to energize selectively in parallel any or all of the twenty transducers 36. The energizing unit 58 receives in parallel on a bus 55 a string of twenty bits corresponding to the dots which are to be printed simultaneously by the twenty nozzles U. The printing bits are processed by a driving logic circuit 60 illustrated in Fig. 5, which comprises a read/write memory 62 with 1024 address locations.

The memory 62 is connected through a bus 64 to a latch 66 for temporary storage of the memory addresses which arrive on a bus 68 from an address multiplexer 70 driven directly by a micro-processor control unit 72 through a bus 74. An adder 76 executes at each cycle a shift by a predetermined number K of places to permit the multiplexer 70 to address correctly the information stored in the memory 62, in accordance with a procedure described later on.

The number K corresponds to the number of dots printable in the pitch "p" between two adjacent nozzles and can assume predetermined values. A manual entering device 80, for example a switch with a plurality of sections, is connected to the adder 76 through the medium of a bus 77 and enables the predetermined number K to be forced into the adder 76 in known manner.

Through a bus 73, the controller 72 addresses a character generator 82 which contains the characters to be printed in columns of dots in accordance with a predetermined matrix. The characters to be printed are extracted from a line memory known *per se* which is connected to the controller 72 and not shown in the drawings. The generator 82 is connected via a bus 83 to the memory 62 for storing in succession the information appertaining to the columns of dots of the characters to be printed.

The memory 62 is constituted by 1024 address locations or positions  $PI_0, \dots, PI_1, \dots, PI_{1024}$  with cyclic updating (Fig. 5). In each address position  $PI_i$  there are stored the twenty bits relating to the dots of each column of the matrix of the character, which is formed in the present case by twenty rows  $L_0, L_1, \dots, L_{19}$  (Fig. 6) (there being twenty nozzles) and a predetermined number of columns, for example forty-eight. The memory 62 is connected through a bus 85 to an output multiplexer 86 for reading the bits corresponding to the twenty nozzles of the head 1. The multiplexer 86 is driven by an up/down counter 90, according to the direction of printing, which is adapted to count cyclically up to twenty, for successively transferring the bits of the dots to be

printed, which are read out of the memory 62, by means of a wire 93 to a bidirectional/shift register 94 having twenty locations and of the serial input and parallel output type. The counting direction of the counter 90 and the shift register 94 is supplied by the controller 72 on a wire 91 on the basis of the desired direction of printing. The register 94 is connected through the bus 55 to the energizing unit 58 (Fig. 1) for transferring all the bits corresponding to the twenty nozzles U thereto in parallel on the basis of an enabling signal transmitted by the controller 72, in synchronism with the clock signal generated by the synchronizing device 17 (Fig. 1). Accordingly, as already mentioned, while the head 1 shifts by one pitch "p", there will be forty-two printing energizations.

When the head 1 is located in a generic position along the printing line L (Figs. 1 and 6), the first nozzle  $U_0$  will print the dot  $P_0$  of a generic column of dots  $C_i$  on a line  $L_0$ , the second nozzle will print the dot  $P_1$  corresponding to a column  $C_{i-42}$  shifted by forty-two printing positions with respect to the column  $C_i$ , and so on, the nozzle  $U_{18}$  will print the dot  $P_{18}$  of the column  $C_{i-756}$  and finally the nozzle  $U_{19}$  will print the dot  $P_{19}$  belonging to the column  $C_{i-798}$ , that is shifted back with respect to the direction of movement of the carriage 10 by 798 printing positions with respect to the first column  $C_i$ .

Taking it that, before beginning printing, the memory 62 is completely erased, the controller 72, addressing the location  $PI_0$  of the memory 62 through the medium of the multiplexer 70 and the latch 66, writes in that location the information appertaining to the column  $C_i$  prepared by the character generator 82. In this state, the counter 90 enables the output multiplexer 86 to extract the bit corresponding to the first nozzle  $U_0$  from the address position of the first column of dots  $C_i$  and to load it into the register 94. Then, assuming  $K=42$ , that is equal to the number of printing positions contained in a pitch "p", the controller 72 causes the latch 66 to change over via the address multiplexer 70 to a memory location  $PI_{-42}$  set back by 42 positions with respect to the preceding one to address therein the information appertaining to the column  $C_{i-42}$  corresponding to the second nozzle  $U_1$  and previously stored in the memory 62 in a stage similar to that hereinbefore described. The shifting by  $K-42$  positions is executed by the adder 72, which adds the number  $K$ , entered on the switch 80, to the serial number of the preceding address.

The counter 90 is incremented or decremented by one so that the multiplexer 86 extracts the bit corresponding to the second nozzle  $U_1$ . This procedure will be repeated by degrees for all the twenty nozzles U. More particularly, the bit corresponding to the twentieth nozzle will be extracted from the last address location  $PI_{798}$ , corresponding to the column  $C_{i-798}$ .

In the end, in the register 94 there will be arranged serially in columns the twenty printing

bits read in the memory 62, which represent the complete information which will be sent in parallel to the energizing unit 58 (Fig. 1) for printing.

After the head 1 has shifted to the right by forty-two printing positions, for example, the second nozzle  $U_1$  has been brought onto the column  $C_i$ , which belonged before to the first nozzle  $U_0$ , the third nozzle  $U_2$  has been brought onto the column  $C_{i-42}$ , and so on, and the last nozzle  $U_{19}$  has been brought into vertical alignment on the penultimate column  $C_{i-756}$ .

Finally, after the head has shifted by 798 printing positions, the nozzle  $U_{19}$  will be in vertical alignment on the column  $C_i$ , which will be printed completely with the twenty dots belonging to it. Proceeding in a similar manner, all the columns of dots will be printed in this way and will form a complete row of vertically printed characters.

The driving circuit of Fig. 5 enables the slope of the printed characters to be varied in one direction or the other with respect to the vertical by a simple operation. To vary the slope of the printed characters, it is sufficient to vary the number  $K$  forced into the adder 76 by means of the switch 80.

By entering a number  $K'$  less than  $K$ , a forward slope of the characters will be obtained, which will be all the more pronounced the more  $K'$  differs from  $K$ . On the other hand, in similar manner, a backward slope of the characters will be obtained by entering a number  $K''$  greater than  $K$ . In fact, let us suppose that we enter a number  $K'=41$  by means of the switch 80. In this situation, the multiplexer 86 will read the information of the column of dots corresponding to the second nozzle  $U_1$  in an address location in the memory 62 shifted by 41 locations, whereby the second nozzle  $U_1$  will print the dots in positions advanced by one step with respect to the preceding state. In a similar manner, all the other nozzles  $U_2, U_3, \dots, U_{19}$  will print their dot in a position advanced respectively by one, two, ... nineteen printing positions with respect to the normal state. In this way, an alignment of the dots of each printed column which is sloped forward will be obtained. In a completely similar manner, a backward slope of the columns of printed dots will be obtained if  $K$  is taken as greater than 42.

The printing speed can be considerably increased due to the cyclic updating of the memory 62. In fact, as already described hereinbefore, the information relating to the columns of dots of the characters to be printed is stored in the memory 62 in cyclic succession; simultaneously, the output multiplexer 86 extracts successively from each column just stored a bit corresponding to the dot to be printed by means of each of the twenty nozzles of the head. In consequence, due to the simultaneousness of the writing and reading of the information in the memory 62, the speed of loading of the register 94 by the multiplexer 86 is considerably increased. As a result, the printing speed of the

nozzles can also be increased up to values such as to be able to turn to account the maximum frequency of repetition of the emission of drops of ink by each piezoelectric element.

Among many possible modifications, we mention that the number K selected to vary the slope of the characters may be entered directly from the controller 72 instead of through the switch 80 (Fig. 5). In this case, the number K selected is forced directly by the controller 72 into the adder 76 on the basis of predetermined instructions processed by the controller in response to predetermined commands received in known manner. Consequently, the entering device 80 in Fig. 5 is eliminated and the bus 77 is connected between the controller 72 and the adder 76.

Moreover, in order to facilitate the operations of mounting and removal of the head of Figs. 1 and 2, the tubes 24 can be cut so as not to project from the rear plate 5 (Fig. 7). Small pieces of tubing 24' projecting inside the container 34 are cemented through the front plate 33' of the container 34. The tubes 30 are fitted over these small pieces 24'. In this way, the container 34 can be separated from the block 48 without having to slip the tubes 30 off the tubes 24. The plate 33' of the container 34 is fixed rigidly by means of screws and locating pins, not shown in the drawing, so as to ensure registration between the tubes 24 and 24'.

#### Claims

1. An ink jet printing head (1) comprising a plurality of tubes (24) for ejecting ink, each ink ejecting tube being provided with a transducer (36) selectively operable for expelling a drop of ink through a corresponding nozzle (U), the ink ejecting tubes (24) being secured to a supporting structure (2, 34) and each being supplied with ink by an ink conducting tube (30) connected to an ink reservoir (31) and made of a flexible material of a length greater than the distance between each ejecting tube and the reservoir, characterised in that the ink conducting tubes (30) are wound by a common winding member (130) carried by the supporting structure (2, 34), the winding member being located between the ink ejecting tubes (24) and a common reservoir (31), each ink conducting tube (30) being helically wound on the outside of the winding member (130) in an arrangement which optimises the utilization of space.

2. A printing head according to claim 1, characterised in that the axis of the helically wound conducting tubes (30) is perpendicular to the ink ejecting tubes (24).

3. A printing head according to claim 1 or 2, characterised in that the winding member (130) comprises a cylindrical drum fixed to the supporting structure (2, 34), each ink conducting tube (30) being wound around the drum (130) for one and a half turns, between diametrically opposite positions on the circumference of the drum.

4. A printing head according to claim 3, characterised in that the ink conducting tubes (30) are wound around the drum (130) so that each half

turn on the drum left free by one of the ink conducting tubes is occupied by the first half turn of an adjacent ink conducting tube, whereby the axial length of the drum occupied by the ink conducting tubes is minimised.

5. A printing head according to claim 3 or 4, characterised in that the structure (2, 34) is carried by a carriage (10) movable with respect to a printing support (16), and in that the reservoir (31) is connected through a flexible conduit (32) to a stationary ink tank.

6. A printing head according to claim 5, wherein the ink ejecting tubes (24) are parallel to one another and lie in a plane inclined with respect to the direction of movement of the carriage (10), characterised in that the supporting structure comprises front and back parallel spaced plates (3, 5), the ink ejecting tubes (24) being perpendicular to and fixed to the plates, the plates defining a first cavity therebetween, and the first cavity being filled with a polymerizable resin (48), whereby the plates (3, 5), the tubes (24) and the resin (48) form a single block.

7. A printing head according to claim 6, characterised in that each ink ejecting tube (24) projects beyond the back plate and is connected to the reservoir (31) by means of a flexible ink conducting tube (30) secured to the projecting end of the tube, the ink conducting tubes (30) being supported by a fixed cylindrical drum (130) mounted on the supporting structure (2, 34) with the ink conducting tubes (30) passing around the drum (130) alternately in opposite directions for one and a half turns so as to minimise the axial length of the drum occupied by the ink conducting tubes.

8. A printing head according to claim 6, characterised in that the supporting structure (2, 34) comprises a second cavity adjacent to the first cavity, the second cavity being formed in a container (34) and bounded by a third plate (33), the container (34) being disengageably attachable to the block (3, 5, 24, 48) in a position in which the third plate and the back plate (5) are adjacent and tubular connecting means (24') mounted on the third plate are aligned with the ink ejecting tubes (24), the tubular connecting means (24') each having an end projecting into the second cavity beyond the third plate (33') and the ink conducting tubes (30) being connected to the said projecting ends.

9. A printing head according to claim 6, 7 or 8, characterised in that the transducers are electrically connected to a printed circuit element (40) disposed in the first cavity of the structure and perpendicularly to the ink ejecting tubes (24), the element being traversed by the transducers and projecting from the resin block, whereby the transducers are electrically accessible from outside.

#### Patentansprüche

1. Tintenstrahl-Druckkopf (1) mit mehreren Röhren (24) zum Ausstoßen von Tinte, wobei jede

Tintenausstoßröhre mit einem Umformer (36) versehen ist, der wählbar zum Ausstoßen eines Tropfens Tinte durch eine entsprechende Düse (U) betätigbar ist, die Tintenausstoßröhren (24) an einem Traggestell (2, 34) befestigt und jeweils mit Tinte über eine Tintenrohrleitung (30) versorgt werden, die mit einem Tintenvorratsraum (31) verbunden und aus flexiblem Material in einer Länge hergestellt ist, die größer als der Abstand zwischen jedem Ausstoßrohr und dem Vorratsraum ist, dadurch gekennzeichnet, daß die Tintenrohrleitungen (30) auf einen gemeinsamen Wickelkörper (130) gewickelt sind, der von dem Traggestell (2, 34) getragen wird und zwischen den Tintenausstoßröhren (24) und einem gemeinsamen Vorratsraum (31) angeordnet ist, wobei jede Tintenrohrleitung (30) schraubenlinienförmig auf der Außenseite des Wickelkörpers (130) in einer Anordnung herumgewickelt ist, die eine optimale Raumausnutzung ergibt.

2. Druckkopf nach Anspruch 1, dadurch gekennzeichnet, daß die Achse der schraubenlinienförmig gewickelten Tintenrohrleitungen (30) senkrecht zu den Tintenausstoßröhren (24) steht.

3. Druckkopf nach Anspruch 1 oder 2, dadurch gekennzeichnet, daß der Wickelkörper (130) eine zylindrische Trommel aufweist, die am Traggestell (2, 34) befestigt ist, wobei jede Tintenrohrleitung (30) mit eineinhalb Windungen um die Trommel zwischen sich auf dem Umfang der Trommel diametral gegenüberliegenden Stellen herumgewickelt ist.

4. Druckkopf nach Anspruch 3, dadurch gekennzeichnet, daß die Tintenrohrleitungen (30) so um die Trommel (130) herumgewickelt sind, daß jede von einer der Tintenrohrleitungen freigelassene Windungshälfte durch die erste Windungshälfte einer benachbarten Tintenrohrleitung belegt ist, so daß die durch die Tintenrohrleitungen belegte axiale Länge der Trommel minimal ist.

5. Druckkopf nach Anspruch 3 oder 4, dadurch gekennzeichnet, daß das Gestell (2, 34) auf einem relativ zu einem Drucksupport (16) bewegbaren Wagen (10) gelagert ist und daß der Vorratsraum (31) durch eine flexible Leitung (32) mit einem ortsfesten Tintenbehälter verbunden ist.

6. Druckkopf nach Anspruch 5, bei dem die Tintenausstoßröhren (24) parallel zueinander und in einer in bezug auf die Bewegungsrichtung des Wagens (10) geneigten Ebene liegen, dadurch gekennzeichnet, daß das Traggestell eine vordere und eine hintere Platte (3, 5) aufweist, die parallel und in einem Abstand voneinander angeordnet sind, daß die Tintenausstoßröhren (24) senkrecht zu und an den Platten befestigt sind, daß die Platten einen ersten Hohlraum mit einem polymerisierbaren Harz (48) gefüllt ist, so daß die Platten (3, 5), die Röhren (24) und das Harz (48) einen einzigen Block bilden.

7. Druckkopf nach Anspruch 6, dadurch gekennzeichnet, daß jede Tintenausstoßröhre (24) über die hintere Platte hinausragt und mit dem Vorratsraum (31) durch eine flexible Tintenrohrleitung (30) verbunden ist, die an dem vorstehenden Ende der Röhre angeschlossen ist, daß die Tinten-

rohrleitungen (30) durch eine feststehende zylindrische Trommel (130) abgestützt sind, die auf dem Traggestell (2, 34) gelagert ist, und daß die Tintenrohrleitungen (30) abwechselnd in entgegengesetzten Richtungen um eineinhalb Windungen um die Trommel (130) herumlaufen, so daß die axiale Länge der von den Tintenrohrleitungen belegten Trommel minimal ist.

8. Druckkopf nach Anspruch 6, dadurch gekennzeichnet, daß das Traggestell (2, 34) einen zweiten Hohlraum neben dem ersten Hohlraum aufweist, daß der zweite Hohlraum in einem Behälter (34) ausgebildet und durch eine dritte Platte (33) begrenzt ist, und daß der Behälter (34) lösbar mit dem Block (3, 5, 24, 48) in einer Lage verbindbar ist, in der die dritte Platte und die hintere Platte (5) nebeneinanderliegen und rohrartige Verbindungsmittel (24'), die auf der dritten Platte gelagert sind, mit den Tintenausstoßröhren (24) fluchten, wobei die rohrartigen Verbindungsmittel (24') jeweils ein Ende aufweisen, das in den zweiten Hohlraum jenseits der dritten Platte (33') ragt und mit jeweils einer der Tintenrohrleitungen (30) verbunden ist.

9. Druckkopf nach einem der Ansprüche 6, 7 oder 8, dadurch gekennzeichnet, daß die Umformer elektrisch mit einem gedruckten Schaltungselement (40) verbunden sind, das in dem ersten Hohlraum des Gestells und senkrecht zu den Tintenausstoßröhren (24) angeordnet ist, von den Umformern quer durchsetzt ist und aus dem Harzblock vorsteht, so daß die Umformer von außen elektrisch zugänglich sind.

## Revendications

1. Tête d'impression à jet d'encre (1) comprenant une pluralité de tubes (24) destinés à éjecter l'encre, chaque tube d'éjection d'encre étant muni d'un transducteur (36) qui peut être sélectivement mis en action pour expulser une gouttelette d'encre à travers une buse (U) correspondante, les tubes d'éjection d'encre (24) étant fixés à une structure support (2, 34) et chacun d'eux étant alimenté en encre par un tube conducteur d'encre (30) relié à un réservoir d'encre (31) et fait d'une matière flexible d'une longueur supérieure à la distance qui sépare chaque tube d'éjection du réservoir, caractérisée en ce que les tubes conducteurs d'encre (30) sont enroulés au moyen d'un élément d'enroulement commun (130) porté par la structure support (2, 34), l'élément d'enroulement étant placé entre les tubes d'éjection d'encre (24) et un réservoir commun (31), chaque tube conducteur d'encre (30) étant enroulé en hélice sur l'extérieur de l'élément d'enroulement (130) dans une disposition qui optimise l'utilisation de l'espace.

2. Tête d'impression selon la revendication 1, caractérisée en ce que l'axe des tubes (30) enroulés en hélice est perpendiculaire aux tubes d'éjection d'encre (24).

3. Tête d'impression selon la revendication 1 ou 2, caractérisée en ce que l'élément d'enroulement (130) comprend un tambour cylindrique fixé à la

structure support (2, 34), chaque tube conducteur d'encre (30) étant enroulé sur un tour et demi autour du tambour (130), entre des emplacements diamétralement opposés de la circonférence du tambour.

4. Tête d'impression selon la revendication 3, caractérisée en ce que les tubes conducteurs d'encre (30) sont enroulés autour du tambour (130) de telle manière que chaque demi-tour du tambour qui est liassé libre par l'un des tubes conducteurs d'encre soit occupé par le premier demi-tour d'un tube conducteur d'encre adjacent, de sorte que la longueur axiale du tambour qui est occupée par les tubes conducteurs d'encre est ainsi réduite à un minimum.

5. Tête d'impression selon la revendication 3 ou 4, caractérisée en ce que la structure (2, 34) est supportée par un chariot (10) qui peut se déplacer par rapport à un support d'impression (16) et en ce que le réservoir (31) est relié à un réservoir d'encre fixe par un conduit flexible (32).

6. Tête d'impression selon la revendication 5, dans laquelle les tubes d'éjection d'encre (24) sont parallèles entre eux et sont contenus dans un plan qui est incliné par rapport à la direction du mouvement du chariot (10), caractérisée en ce que la structure support comprend des plaques avant et arrière (3, 5), parallèles et espacées, les tubes d'éjection d'encre (24) étant perpendiculaires et fixés aux plaques, les plaques définissant entre elles une première cavité et la première cavité étant remplie d'une résine polymérisable (48), de sorte que les plaques (3, 5), les tubes (24) et la résine (48) forment un seul bloc.

7. Tête d'impression selon la revendication 6, caractérisée en ce que chaque tube d'éjection d'encre (24) fait saillie au-delà de la plaque arrière et est relié au réservoir (31) au moyen d'un tube

conducteur d'encre flexible (30) qui est fixé à l'extrémité saillante du tube, les tubes conducteurs d'encre (30) étant supportés par un tambour cylindrique fixe (130) monté sur la structure support (2, 34), et les tubes conducteurs d'encre (30) passant autour du tambour (130) sur un tour et demi, alternativement dans des sens opposés, de manière à réduire à un minimum la longueur axiale du tambour qui est occupée par les tubes conducteurs d'encre.

8. Tête d'impression selon la revendication 6, caractérisée en ce que la structure support (2, 34) comprend une deuxième cavité adjacente à la première cavité, la deuxième cavité étant formée dans un récipient (34) et étant limitée par un troisième plaque (33), le récipient (34) pouvant être fixé au bloc (3, 5, 24, 48) de façon démontable, dans une position dans laquelle la troisième plaque et la plaque arrière (5) sont adjacentes, cependant que des moyens de liaison tubulaires (24') qui sont montés sur la troisième plaque sont alignés avec les tubes d'éjection d'encre (24), les moyens de liaison tubulaires (24') ayant chacun une extrémité qui fait saillie dans la deuxième cavité au-delà de la troisième plaque (33') et les tubes conducteurs d'encre (30) étant reliés à ces extrémités saillantes.

9. Tête d'impression selon la revendication 6, 7 ou 8, caractérisée en ce que les transducteurs sont connectés électriquement à un élément de circuit imprimé (40) disposé dans la première cavité de la structure, perpendiculairement aux tubes d'éjection d'encre (24), l'élément étant traversé par les transducteurs et faisant saillie à partir du bloc de résine, de sorte que les transducteurs sont ainsi électriquement accessibles de l'extérieur.

40

45

50

55

60

65

7

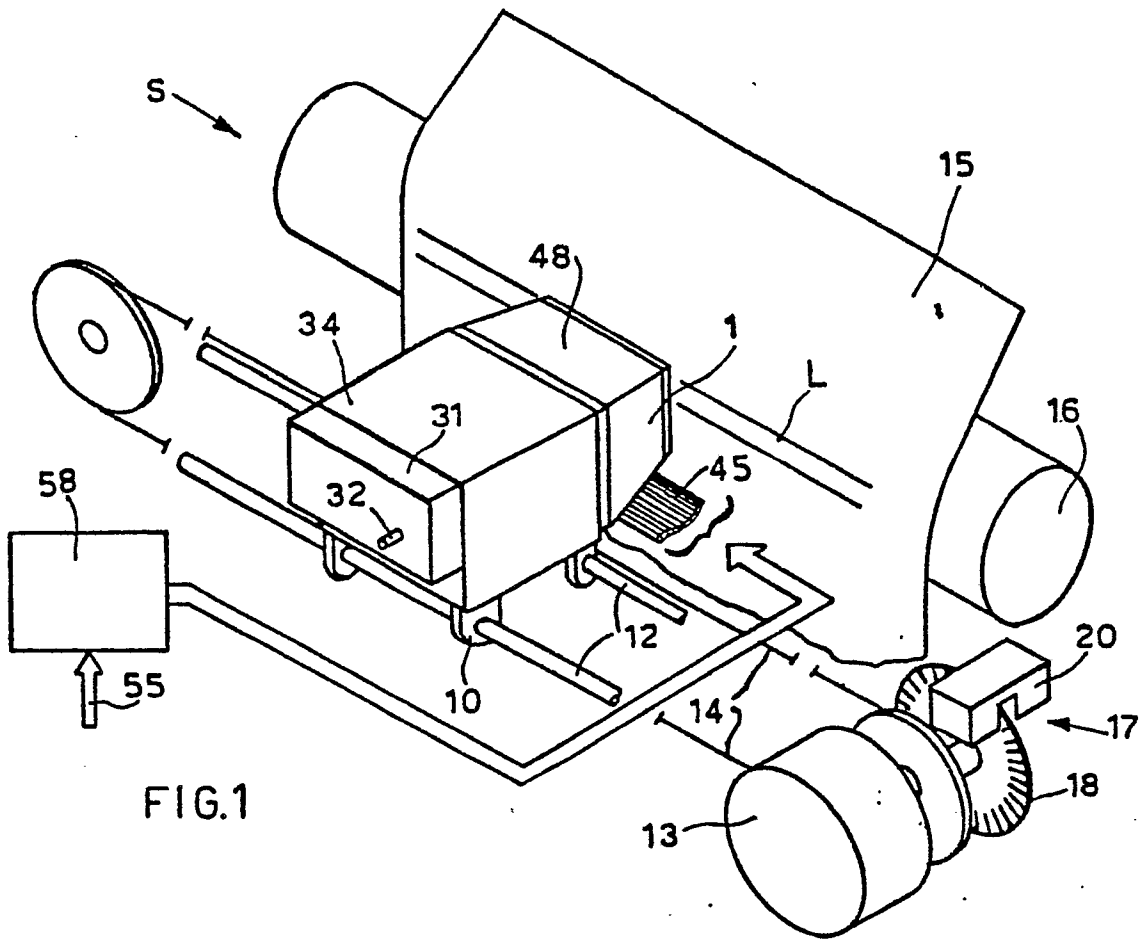

FIG.1

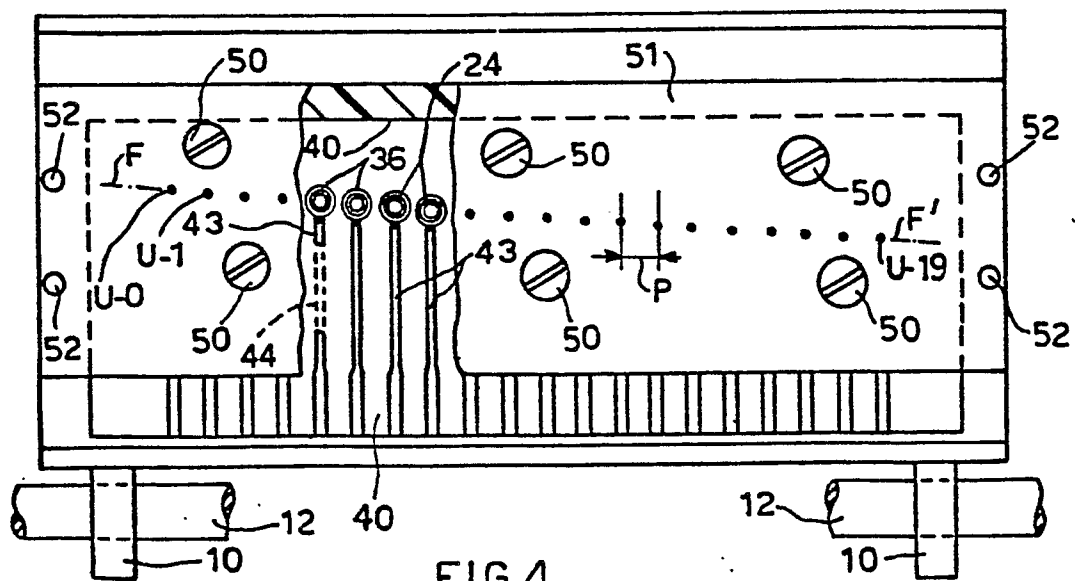
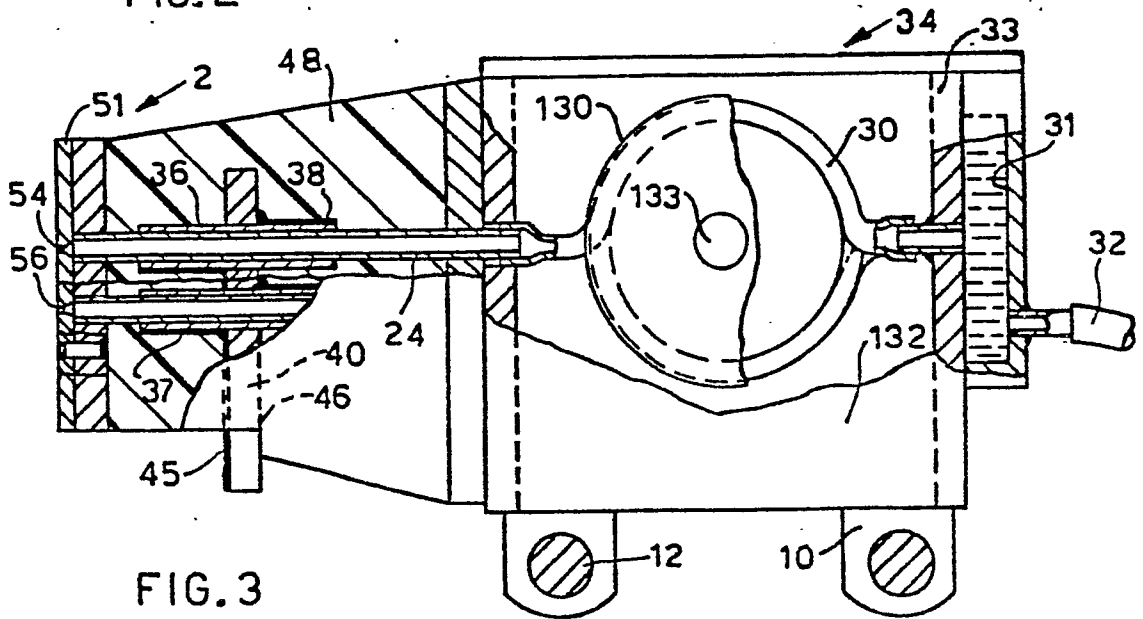
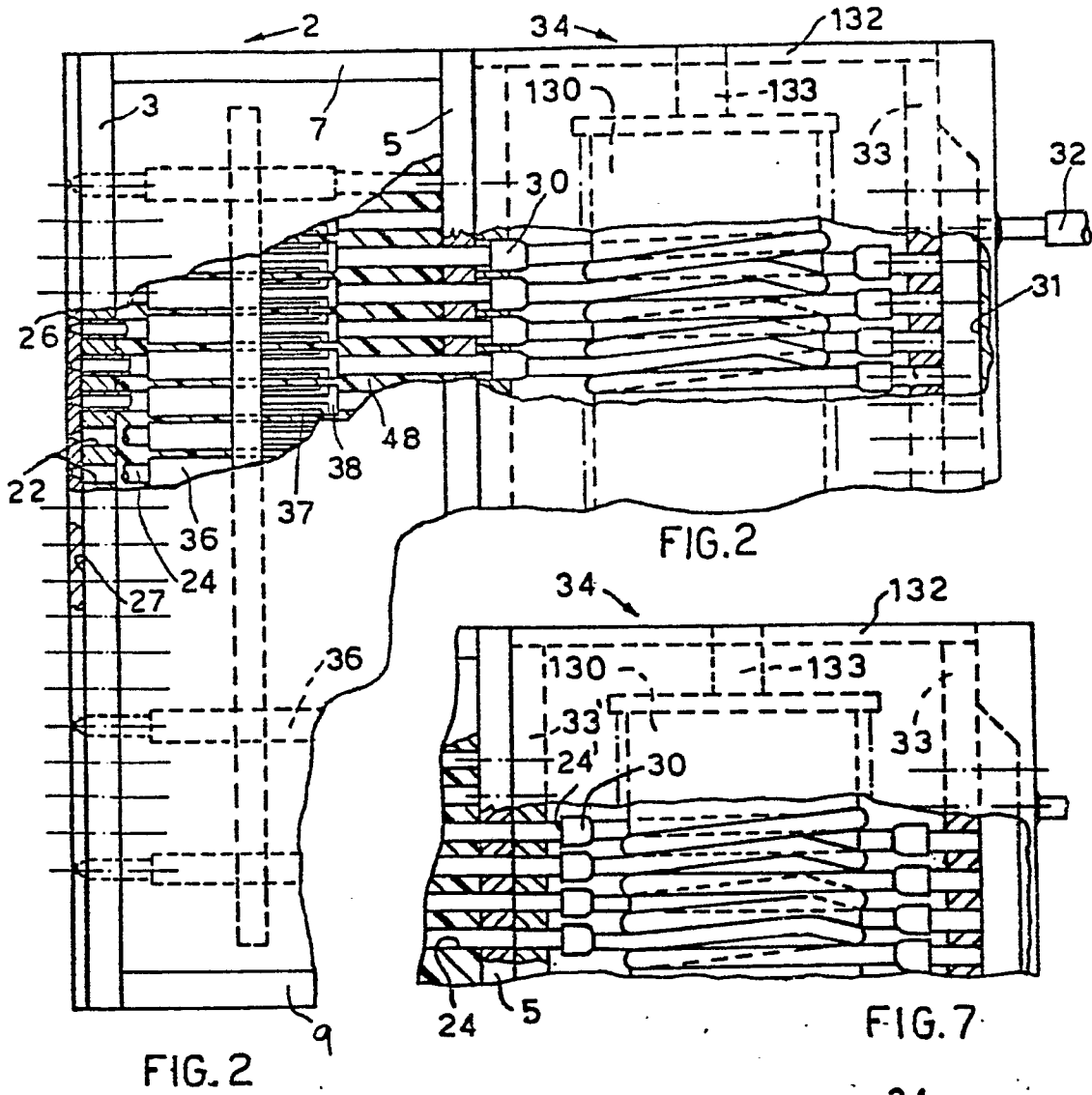

FIG.4



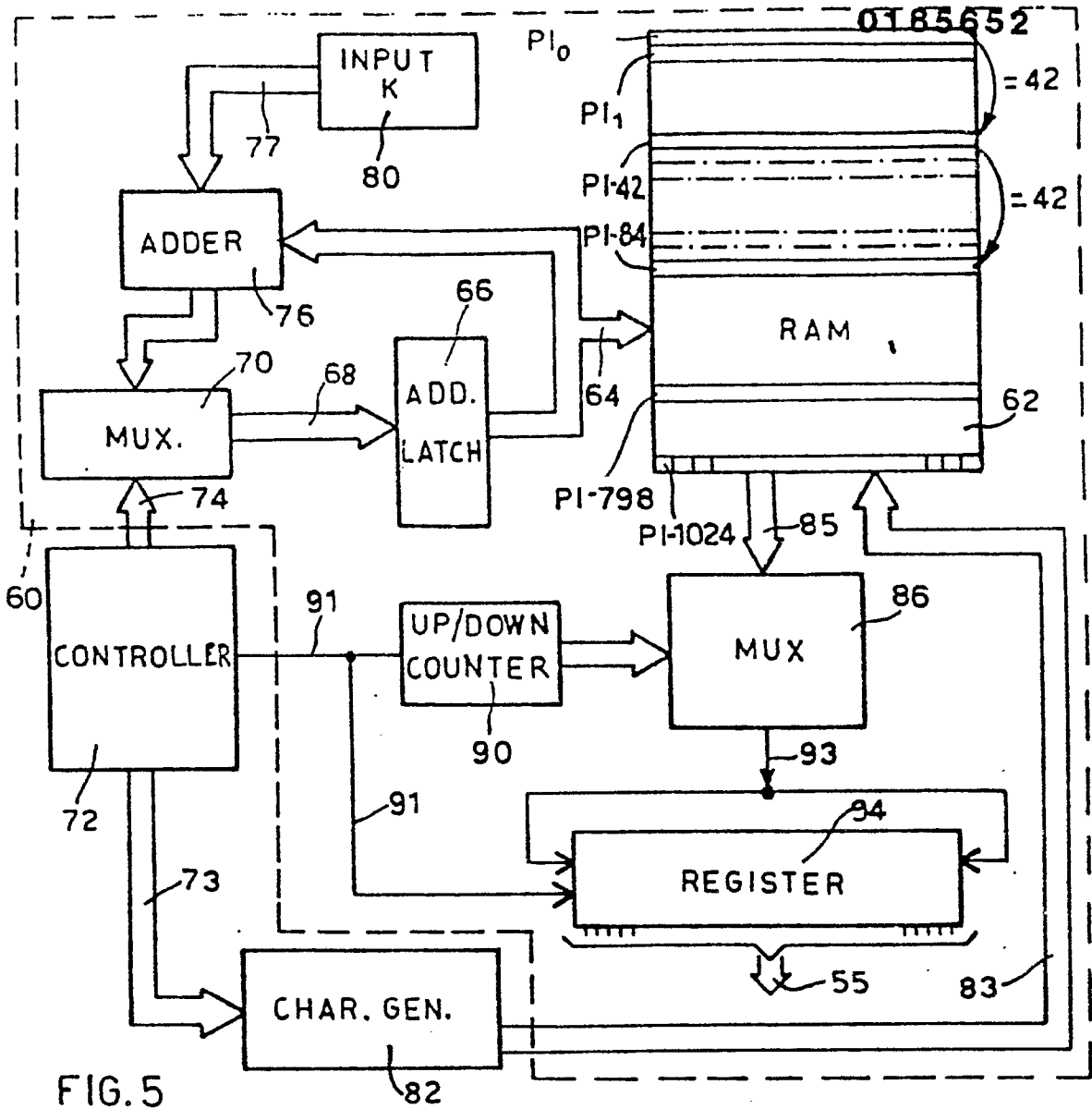

FIG. 5

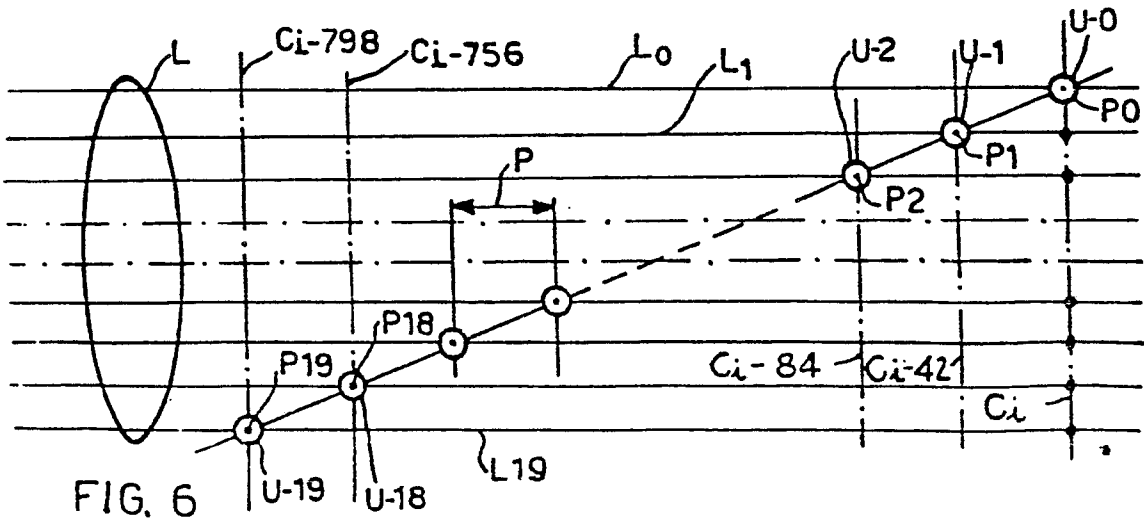

FIG. 6