



(43) International Publication Date
21 November 2013 (21.11.2013)

- (51) International Patent Classification:
F04B 45/04 (2006.01)
- (21) International Application Number:
PCT/GB2013/051004
- (22) International Filing Date:
22 April 2013 (22.04.2013)
- (25) Filing Language: English
- (26) Publication Language: English
- (30) Priority Data:
1208710.2 17 May 2012 (17.05.2012) GB
- (71) Applicant (for all designated States except US): **SELWOOD GROUP LIMITED** [GB/GB]; Bournemouth Road, Chandlers Ford, Eastleigh, Hampshire SO53 3ZL (GB).
- (72) Inventors; and
(71) Applicants (for US only): **PHIPPS, Roy Walter** [GB/GB]; Selwood Group Limited, Bournemouth Road, Chandlers Ford, Eastleigh, Hampshire SO53 3ZL (GB). **BRADBURY, Lawrence** [GB/GB]; Selwood Group Limited, Bournemouth Road, Chandlers Ford, Eastleigh SO53 3ZL (GB).
- (74) Agent: **FORRESTERS**; Chamberlain House, Paradise Place, Birmingham, West Midlands B3 3HP (GB).

- (81) Designated States (unless otherwise indicated, for every kind of national protection available): AE, AG, AL, AM, AO, AT, AU, AZ, BA, BB, BG, BH, BN, BR, BW, BY, BZ, CA, CH, CL, CN, CO, CR, CU, CZ, DE, DK, DM, DO, DZ, EC, EE, EG, ES, FI, GB, GD, GE, GH, GM, GT, HN, HR, HU, ID, IL, IN, IS, JP, KE, KG, KM, KN, KP, KR, KZ, LA, LC, LK, LR, LS, LT, LU, LY, MA, MD, ME, MG, MK, MN, MW, MX, MY, MZ, NA, NG, NI, NO, NZ, OM, PA, PE, PG, PH, PL, PT, QA, RO, RS, RU, RW, SC, SD, SE, SG, SK, SL, SM, ST, SV, SY, TH, TJ, TM, TN, TR, TT, TZ, UA, UG, US, UZ, VC, VN, ZA, ZM, ZW.
- (84) Designated States (unless otherwise indicated, for every kind of regional protection available): ARIPO (BW, GH, GM, KE, LR, LS, MW, MZ, NA, RW, SD, SL, SZ, TZ, UG, ZM, ZW), Eurasian (AM, AZ, BY, KG, KZ, RU, TJ, TM), European (AL, AT, BE, BG, CH, CY, CZ, DE, DK, EE, ES, FI, FR, GB, GR, HR, HU, IE, IS, IT, LT, LU, LV, MC, MK, MT, NL, NO, PL, PT, RO, RS, SE, SI, SK, SM, TR), OAPI (BF, BJ, CF, CG, CI, CM, GA, GN, GQ, GW, ML, MR, NE, SN, TD, TG).

Published:
— with international search report (Art. 21(3))

(54) Title: DIAPHRAGM PUMP

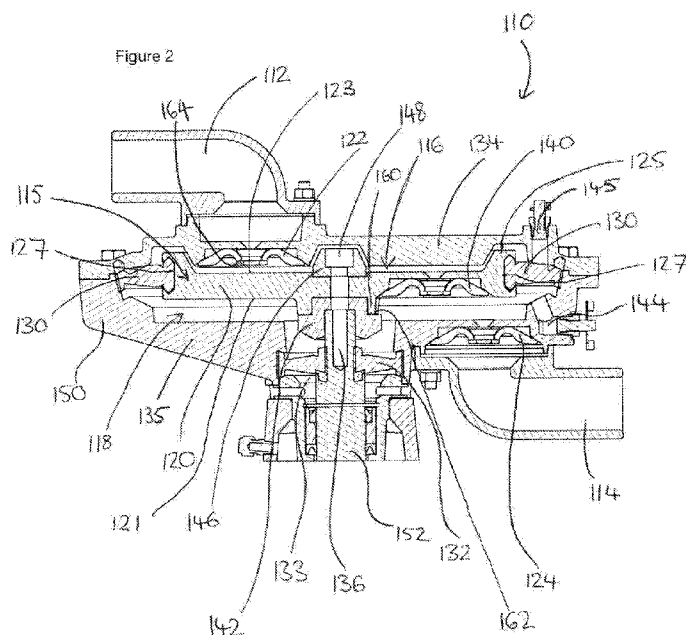

(57) Abstract: A pump (110) including a housing having an inlet (112) and an outlet (114) with a respective one way inlet valve (122) configured to allow flow of fluid into the housing and one way outlet valve (124) configured to allow flow of fluid out of the housing, a pump arrangement (115) having a piston member (120) positioned in the housing and a drive member (135), the drive member (135) extending through a drive member opening (133) in the housing and being operable to cause axial movement of the piston member (120) in first and second opposite directions, a piston seal (130) extending between the piston member (120) and the housing so as to separate a volume within the housing into a first chamber (116) defining a first volume at one side of the piston member (120) and a second chamber (118) defining a second volume at the other side of the piston member (120) and being in fluid communication with the drive member opening (133), the piston member (120) having a piston valve (140) allowing flow of fluid from the first chamber (116) to the second chamber (118), such that movement of the piston member (120) in the first direction causes the first volume to increase and the second volume to decrease thereby causing fluid to flow into the first chamber (116) through the inlet valve (122) and causing fluid to flow from the second chamber (118) through the outlet valve (124), and such that movement

of the piston member in the second direction causes the first volume to decrease, thereby causing fluid to flow from the first chamber (116) into the second chamber (118) through the piston valve (140), and a drive member seal (132) through which the drive member (135) extends, that inhibits flow of fluid from the second chamber (118) through the drive member opening (133) in the housing.

DIAPHRAGM PUMP

5 Description of Invention

The present invention relates to a pump and in particular to a vacuum seal pump, of the sort generally known as a double acting diaphragm pump.

10 Vacuum seal pumps are generally known and are used to remove a fluid, typically air, from a sealed volume. Diaphragm pumps use positive displacement to remove the fluid – by expanding the volume of a first chamber, allowing fluid to flow into the chamber through an inlet, sealing the inlet, and exhausting gas from the chamber. Pumps of the type known as
15 double-acting diaphragm pumps include a mechanically-operated diaphragm that divides the chamber into a first and a second chamber. Fluid from the first chamber is vented to the second chamber as the diaphragm is operated to reduce the volume in the first chamber and increase the volume in the second, typically through a check valve in the diaphragm. On returning the diaphragm
20 to its initial position, the second chamber is compressed, and fluid is vented from the second chamber through an outlet.

Vacuum seal pumps generally require a piston of relatively large sectional thickness, in order to generate and withstand the pressures required to force
25 fluid through the pump to create a partial vacuum. Typically a piston is provided with a counter bore arrangement into which a drive rod locates, to provide the pumping arrangement for working the pump. Pistons of the prior art are susceptible to seizing in place, and in such circumstance, may require replacement of either the piston or driver rod where one or both parts are
30 damaged in freeing the piston.

In double-acting diaphragm pumps, the valve between the first and second chambers is disposed centrally on the axis of the piston. A valve of substantial thickness is typically required, to withstand the pressures generated by the crankshaft in moving the piston. Such a valve can require a relatively high
5 pressure to cause the valve to open, which in turn can result in a noisy operation.

In order to seal the chamber of the pump from atmosphere, a seal is provided surrounding the drive shaft that operates the piston. This seal is flexible, to
10 allow movement of the shaft, and typically forms a part of the wall of the first chamber, into which fluid is drawn from the inlet. As a consequence of the seal being flexible, the volume of the first chamber increases under pressure, as the seal flexes outwardly of the chamber, which reduces the compression ratio of the pump. Typically, the terminal pressure achieved by a pump of this
15 type is approximately 25-25.5"Hg (84,425-86114Pa). A further disadvantage of a pump in which the seal forms a part of the wall of the first chamber, is that in the event of seal failure, the first chamber loses its priming ability entirely, rendering the pump inoperable.

20 With reference to Figure 1 of the drawings, a fluid pump 10 of the type known in the art is shown, the pump 10 having a housing 35 with an inlet 12 and an outlet 14 with respective inlet valve 22 configured to allow flow of fluid into the housing 35 and outlet valve 24 configured to allow flow of fluid out of the housing 35. The fluid pumped by the device is generally air, although it should
25 be understood that the pump may be used to pump other fluids.

The pump 10 includes a pumping arrangement (generally shown at 15) having a piston member 20 and a drive member 38, the drive member 38 extending through a drive member opening 33 in the housing 35. The drive member 38
30 is operable to cause axial movement of the piston member 20 in first and second opposite directions. A piston seal 30 is disposed between the edge of

the piston member 20 and the housing, surrounding perimeter of the piston member 20, so as to separate the volume within the housing into a first chamber 16 defining a first volume within the housing 25 and a second chamber 18 defining a second volume within the housing 35. The piston member 20 has a piston valve (generally shown at 26), located on the central axis of the piston member and drive member 38, allowing flow of fluid from the first chamber 16 to the second chamber 18 when the fluid in the first chamber is under pressure. A drive member seal 32 is disposed adjacent the drive member 38, surrounding the drive member 38, so as to prevent flow of fluid through the opening 33 from the first chamber 16.

Operation of the pump 10 is achieved by movement of the drive member 38 in the first and second directions, causing respective movement of the piston member 20 to increase and decrease the volumes of the first and second chambers, respectively. By moving the piston member 20 in a first direction, from a first position in which the volume of the first chamber 16 is relatively small, and the volume of the second chamber 18 is relatively large, to a second position in which the volume of the first chamber 16 is relatively large and the volume of the second chamber 18 is relatively small, fluid is caused to flow into the first chamber 16 through the inlet valve 22, and from the second chamber 18 through the outlet valve 24. Movement of the piston member 20 in the second direction causes the first volume to decrease and the second volume to increase, thereby causing fluid to flow from the first chamber 16 into the second chamber 18 through the piston valve 26.

25

An aspect of the invention provides a pump including:

a housing having an inlet and an outlet with a respective one way inlet valve configured to allow flow of fluid into the housing and a one way outlet valve configured to allow flow of fluid out of the housing,

30

a pumping arrangement having a piston member positioned in the housing and a drive member, the drive member extending through a drive

member opening in the housing and being operable to cause axial movement of the piston member in first and second opposite directions,

a piston seal extending between the piston member and the housing so as to separate a volume within the housing into a first chamber defining a first volume at one side of the piston member and a second chamber defining a second volume at the other side of the piston member and being in fluid communication with the drive member opening, the piston member having a piston valve allowing flow of fluid from the first chamber to the second chamber, such that movement of the piston member in the first direction causes the first volume to increase and the second volume to decrease thereby causing fluid to flow into the first chamber through the inlet valve and causing fluid to flow from the second chamber through the outlet valve, and such that movement of the piston member in the second direction causes the first volume to decrease, thereby causing fluid to flow from the first chamber into the second chamber through the piston valve, and

a drive member seal through which the drive member extends, that inhibits flow of fluid from the second chamber through the drive member opening in the housing.

Another aspect of the invention provides a pump, including:

a housing having an inlet and an outlet with a respective one way inlet valve configured to allow flow of fluid into the housing and a one way outlet valve configured to allow flow of fluid out of the housing,

a pumping arrangement having a piston member positioned in the housing and a drive member substantially coaxial with the piston member, the drive member being operable to cause axial movement of the piston member in first and second opposite directions, and

a piston seal extending between the piston member and the housing so as to separate a volume within the housing into a first chamber defining a first volume at one side of the piston member and a second chamber defining a second volume at the other side of the piston, the piston member having a

piston valve disposed at a position spaced radially from a central axis of the piston member and configured to enable flow of fluid from the first chamber to the second chamber, such that movement of the piston member in the first direction causes the first volume to increase and the second volume to decrease thereby causing fluid to flow into the first chamber through the inlet valve and causing fluid to flow from the second chamber through the outlet valve, and such that movement of the piston member in the second direction causes the first volume to decrease, thereby causing fluid to flow from the first chamber into the second chamber through the piston valve.

10

Another aspect of the invention provides a pump including:

a housing having an inlet and an outlet with a respective one way inlet valve configured to allow flow of fluid into the housing and a one way outlet valve configured to allow flow of fluid out of the housing,

15

a pumping arrangement having a piston member positioned in the housing and a substantially coaxial drive member, the drive member being operable to cause axial movement of the piston member in first and second opposite directions,

20

a piston seal extending between the piston member and the housing so as to separate a volume within the housing into a first chamber defining a first volume at one side of the piston member and a second chamber defining a second volume at the other side of the piston, the piston member having a piston valve allowing flow of fluid from the first chamber to the second chamber, such that movement of the piston member in the first direction causes the first volume to increase and the second volume to decrease thereby causing fluid to flow into the first chamber through the inlet valve and causing fluid to flow from the second chamber through the outlet valve, and such that movement of the piston member in the second direction causes the first volume to decrease, thereby causing fluid to flow from the first chamber into the second chamber through the piston valve, and

30

a connection arrangement between the piston member and drive member, comprising:

a first connection member supported on the drive member and positioned at one side of the piston member,

5 a second connection member positioned at an opposite side of the piston member, and

a securing means for holding the first and second connection members relative each other so as to hold the piston member relative to the drive member in a clamped arrangement between the first and second
10 connection members, substantially to prevent axial or radial relative movement therebetween.

Further features of the invention are set forth in the dependent claims appended hereto.

15

An embodiment of the invention will now be described by way of example only with reference to the accompanying drawings of which

FIGURE 2 shows a cross-section through a pump according to the invention,

FIGURE 3 shows a valve of the type included in a pump according to the
20 invention,

FIGURE 4 shows a pumping arrangement of a pump according to the invention,

FIGURE 5 shows a cross-section through a pump according to the invention, with its pumping arrangement in a first position, and

25 FIGURE 6 shows the pump of FIGURE 5 having its pumping arrangement in a second position.

A pump according to embodiments of the invention is now described with reference to Figures 2 to 6, wherein a pump 110 is shown, the pump having a
30 housing 135 with an inlet 112 and an outlet 114 with a respective inlet valve 122 configured to allow flow of fluid into the housing 135 and outlet valve 124

configured to allow flow of fluid out of the housing 135. The housing 135 is generally comprised of a first casing 134 and a second casing 150, forming a substantially enclosed volume, the first and second casings being fastened to one another by bolts, or the like, and including a fluid-tight seal, e.g. such as a gasket, therebetween. The pump 110 includes a pumping arrangement 115 having a piston member 120 and a drive member 152, the drive member 152 extending through a drive member opening 133 in the housing 135 and being operable to cause axial movement of the piston member 120 in first and second opposite directions. In embodiments, the drive member 152 is a rod driven by a crankshaft. It will be appreciated that other forms of drive member may be provided, that are operable to effect axial movement of the piston member 120.

In embodiments, the piston member 120 is substantially circular in plan view (e.g. disk-shaped), as is standard, having a first surface 121 and a second, opposite, surface 123. The piston member 120 includes a central axial bore for receiving a securing means 148, such as a bolt. The piston member 120 includes, around its periphery, a portion of increased thickness 125, and a recess 127 inset into its radially outwardly facing edge. Preferably, the piston member 120 has a thickness in the range of 18-37mm.

In embodiments, the pumping arrangement further includes a connection arrangement wherein the piston member 120 is clamped between a first connection member 142 supported on the drive member 152, and a second connection member 146, adapted to engage with the second surface 123 of the piston member 120. The piston member 120 is therefore sandwiched between the first and second connection members (142, 146). The bolt 148 has a threaded shaft 136 which passes through central bores in the piston member 120, first connection member 142 and second connection member 146, and engages with a threaded bore in the drive member 152, so as to hold the piston member 120 relative to the drive member 152.

In embodiments, the first connection member 142 is a first collar, having a central bore adapted to receive an end portion of the drive member 152 and a portion of the securing member 148. In the embodiment of Figure 2, the first collar 142 comprises a projecting formation 162 and the first surface 121 comprises a raised formation 160, in the form of a raised ring, which provides a recess (i.e. within the ring) such that the projecting formation 162 cooperates with the recess as to prevent radial movement of the piston member 120 relative to the first collar 142. Alternatively, the first collar 142 may comprise a recess, and the first surface of the piston member may comprise a corresponding projecting formation. It will be apparent that, as a further alternative, other forms of cooperating formations may be provided to prevent radial movement between the piston member 120 and first collar 142.

In embodiments, the second connection member 146 is a second collar, and has a bearing surface adapted to abut the second surface 123 of the piston member 120. The second surface 123 has a recessed portion at its centre, adapted to receive and locate the bearing surface of the second connection member 146, so as to prevent relative radial movement between therebetween.

A pump having the connection arrangement as described is less susceptible to seizing of the pumping arrangement 115, since the piston member 120 is not connected (e.g. bolted) directly to the drive member 152. By providing first and second connection members 142, 146, the connection between the parts is spaced, allowing greater freedom of movement. Furthermore, in the unlikely event of a seizure occurring, the parts may be disassembled more easily, allowing individual components to be replaced, as it is less likely that the piston member 120 and drive member 152 become irreversibly attached (i.e. seized) to one another in operation. Pumps of the prior art include piston valves that are aligned coaxially with the drive member and piston member. In

such an arrangement, it is not possible to secure the piston member to the drive member by way of an axial securing means, as provided in the present invention.

- 5 The pump 110 includes a piston seal 130 around the perimeter of the piston member 120, connecting the edge of the piston member 120 to an inner wall of the housing 135 and forming a fluid-tight seal therebetween. The piston seal 130 and piston member 120 form a diaphragm separating a first and a second chamber, the first chamber 116 defining a first volume within the housing 135 and the second chamber 118 defining a second volume within the housing 135.

In embodiments, the piston member 120 has a piston valve 140 that is disposed at a position offset axially (i.e. spaced radially) from the central axis of the piston member 120 and drive member 152. Preferably, the piston valve 140 is disposed at a position in the range of 69-97mm from the central axis of the piston member 120. The piston valve 140, inlet valve 124 and outlet valve 122 are all of identical construction, as shown in Figure 3, the valves having a valve seat 154 shaped so as to nest within recessed portions of the housing.

20 The shape of the valves is such that the sealing ring 164 of each valve is 'wiped' down the valve seat 154 in use, which results in a self-cleaning effect, which aids positive sealing of the valve. The valves are of light construction, such that the pressure required to operate the valve is lower than that typically required by valves employed in vacuum pumps of the prior art. The light nature of the valves allows the pump to operate more responsively, and require less power, than other equivalent pumps. With less pressure being required to operate the valves, the pump operates more quietly than standard pumps due to a reduction in sound pressure waves generated by operation of the pump when pumping free air. Furthermore, the commonality of the valves

25 30 means that the production of the pump has lower tooling requirements, resulting in production efficiencies.

The second chamber 118 of the pump 110 has a drive member opening 133 which connects the second chamber 118 to atmosphere. A drive member seal 162 is disposed adjacent, and surrounding, the drive member 152, so as to prevent flow of fluid through the opening 133 from the second chamber 118. The drive member seal 162 is a resiliently flexible seal so as to allow movement of the drive member, whilst maintaining a fluid-tight seal therebetween.

In the event that the drive member seal 162 fails, and pressure is lost from the second chamber 118 to atmosphere, the pump of the invention still retains its priming ability, and the pump 110 may continue to function as a single-stage pump. The action of the piston member 120 causes fluid to be drawn into the first chamber 116, which is sealed from the second chamber 118 by the piston valve 140. This allows the pump to continue to draw fluid into the pump through the inlet, and the single primary stage pump as shown is still capable of up to 22.5”Hg (75983 Pa).

Since the drive member seal 162 is flexible, in pumps that incorporate the seal in the wall of the first chamber, the compression ratio of the pump suffers due to the seal flexing under pressure. This is not the case in the present invention, as the drive member seal is provided in a wall in the second chamber. In the pump of the present invention, the terminal pressure across the pump is improved over the prior art to approximately 27-28”Hg (91179-94556Pa).

In operation, as the piston member 120 moves in the first direction, from a first configuration (Figure 5) to a second configuration (Figure 6), the first volume increases and the second volume decreases, thereby causing fluid to flow into the first chamber 116 through the inlet valve 122. At the same time, fluid flows from the second chamber 118 through the outlet valve 124. Movement of the

piston member 120 in the second direction causes the first volume to decrease and the second volume to increase, thereby causing fluid to flow from the first chamber 116 into the second chamber 118 through the piston valve 140.

- 5 When used in this specification and claims, the terms "comprises" and "comprising" and variations thereof mean that the specified features, steps or integers are included. The terms are not to be interpreted to exclude the presence of other features, steps or components.
- 10 The features disclosed in the foregoing description, or the following claims, or the accompanying drawings, expressed in their specific forms or in terms of a means for performing the disclosed function, or a method or process for attaining the disclosed result, as appropriate, may, separately, or in any combination of such features, be utilised for realising the invention in diverse
- 15 forms thereof.

CLAIMS

1. A pump including:

5 a housing having an inlet and an outlet with a respective one way inlet valve configured to allow flow of fluid into the housing and a one way outlet valve configured to allow flow of fluid out of the housing,

10 a pumping arrangement having a piston member positioned in the housing and a drive member, the drive member extending through a drive member opening in the housing and being operable to cause axial movement of the piston member in first and second opposite directions,

15 a piston seal extending between the piston member and the housing so as to separate a volume within the housing into a first chamber defining a first volume at one side of the piston member and a second chamber defining a second volume at the other side of the piston member and being in fluid communication with the drive member opening, the piston member having a piston valve allowing flow of fluid from the first chamber to the second chamber, such that movement of the piston member in the first direction causes the first volume to increase and the second volume to decrease thereby causing fluid to flow into the first chamber through the inlet valve and causing fluid to flow from the second chamber through the outlet valve, and such that movement of the piston member in the second direction causes the first volume to decrease, thereby causing fluid to flow from the first chamber into the second chamber through the piston valve, and

25 a drive member seal through which the drive member extends, that inhibits flow of fluid from the second chamber through the drive member opening in the housing.

2. A pump according to claim 1, wherein the drive member seal is resiliently deformable.

3. A pump according to claim 1 or claim 2, wherein the drive member is substantially coaxial with the piston member, and the piston valve is disposed at a position spaced radially from a central axis of the piston member.

5 4. A pump according to any one of the preceding claims, further including a connection arrangement between the piston member and drive member, comprising:

a first connection member positioned at one side of the piston member,

10 a second connection member positioned at an opposite side of the piston member, and

a securing means for holding the first and second connection members relative each other so as to hold the piston member relative to the drive member in a clamped arrangement between the first and second connection members, substantially to prevent axial or radial relative movement therebetween.

15

5. A pump, including:

a housing having an inlet and an outlet with a respective one way inlet valve configured to allow flow of fluid into the housing and a one way outlet valve configured to allow flow of fluid out of the housing,

20

a pumping arrangement having a piston member positioned in the housing and a drive member substantially coaxial with the piston member, the drive member being operable to cause axial movement of the piston member in first and second opposite directions, and

25

a piston seal extending between the piston member and the housing so as to separate a volume within the housing into a first chamber defining a first volume at one side of the piston member and a second chamber defining a second volume at the other side of the piston, the piston member having a piston valve disposed at a position spaced radially from a central axis of the piston member and configured to enable flow of fluid from the first chamber to

30

the second chamber, such that movement of the piston member in the first direction causes the first volume to increase and the second volume to decrease thereby causing fluid to flow into the first chamber through the inlet valve and causing fluid to flow from the second chamber through the outlet
5 valve, and such that movement of the piston member in the second direction causes the first volume to decrease, thereby causing fluid to flow from the first chamber into the second chamber through the piston valve.

6. A pump according to claim 3 or claim 5, wherein the piston valve is
10 disposed at a position closer to a periphery of the piston member than to the central axis of the piston member.

7. A pump according to claim 3 or claim 5, wherein the piston valve is
15 disposed at a position closer to a central axis of the piston member than to a periphery of the piston member.

8. A pump according to claim 3 or claim 5, wherein the piston valve is
disposed at a position approximately equally spaced from a periphery of the
20 piston member and from a central axis of the piston member.

9. A pump according to claim 3 or claim 5, wherein the piston valve is
disposed at a position in the range of 69-97mm from the central axis of the
piston member.

25 10. A pump according to claim 3, or any one of claims 5 to 9, further including a connection arrangement between the piston member and drive member, comprising:

a first connection member positioned at one side of the piston
member,

30 a second connection member positioned at an opposite side of the piston member, and

a securing means for holding the first and second connection members relative each other so as to hold the piston member relative to the drive member in a clamped arrangement between the first and second connection members, substantially to prevent axial or radial relative movement
5 therebetween.

11. A pump including:

a housing having an inlet and an outlet with a respective one way inlet valve configured to allow flow of fluid into the housing and a one way outlet
10 valve configured to allow flow of fluid out of the housing,

a pumping arrangement having a piston member positioned in the housing and a substantially coaxial drive member, the drive member being operable to cause axial movement of the piston member in first and second opposite directions,

15 a piston seal extending between the piston member and the housing so as to separate a volume within the housing into a first chamber defining a first volume at one side of the piston member and a second chamber defining a second volume at the other side of the piston, the piston member having a piston valve allowing flow of fluid from the first chamber to the second
20 chamber, such that movement of the piston member in the first direction causes the first volume to increase and the second volume to decrease thereby causing fluid to flow into the first chamber through the inlet valve and causing fluid to flow from the second chamber through the outlet valve, and such that movement of the piston member in the second direction causes the
25 first volume to decrease, thereby causing fluid to flow from the first chamber into the second chamber through the piston valve, and

a connection arrangement between the piston member and drive member, comprising:

a first connection member positioned at one side of the piston
30 member,

a second connection member positioned at an opposite side of the piston member, and

a securing means for holding the first and second connection members relative each other so as to hold the piston member relative to the drive member in a clamped arrangement between the first and second connection members, substantially to prevent axial or radial relative movement therebetween.

12. A pump according to claim 4, claim 10 or claim 11, wherein the first connection member is positioned in the second chamber and the second connection member is positioned in the first chamber.

13. A pump according to claim 4, or to any one of claims 10 to 12, wherein the first connection member has a central bore through which the securing member extends.

14. A pump according to claim 4, or to any one of claims 10 to 13, wherein the second connection means includes a recess to receive the drive member.

15. A pump according to claim 4, or to anyone one of claims 10 to 14, wherein one or both of the first connection member and piston member comprises a location formation, so as to prevent radial movement of the piston member relative to the first connection member.

16. A pump according to claim 15, wherein the location formation comprises a recessed formation or a projecting formation.

17. A pump according to claim 4, or to any one of claims 10 to 16, wherein the second connection member has a central bore through which the securing means extends.

18. A pump according to claim 17, wherein the second connection member is received in a recess in the piston member.

19. A pump according to any one of the preceding claims, wherein each of
5 the input valve, the output valve, and the piston valve is a check valve.

20. A pump according to any one of the preceding claims, wherein the pump includes a discharge valve operable to discharge fluid from the first chamber to atmosphere.

10

21. A pump according to any one of the preceding claims, wherein the pump includes a discharge valve operable to discharge fluid from the second chamber to atmosphere.

15 22. A pump according to any one of the preceding claims, wherein the piston member has a thickness in the range of 18-37mm.

23. A pump substantially as hereinbefore described with reference to and / or as shown in Figures 2 to 6 of the accompanying drawings.

20 24. Any novel feature or novel combination of features described herein and/or in Figures 2 to 6 of the accompanying drawings.

Figure 1

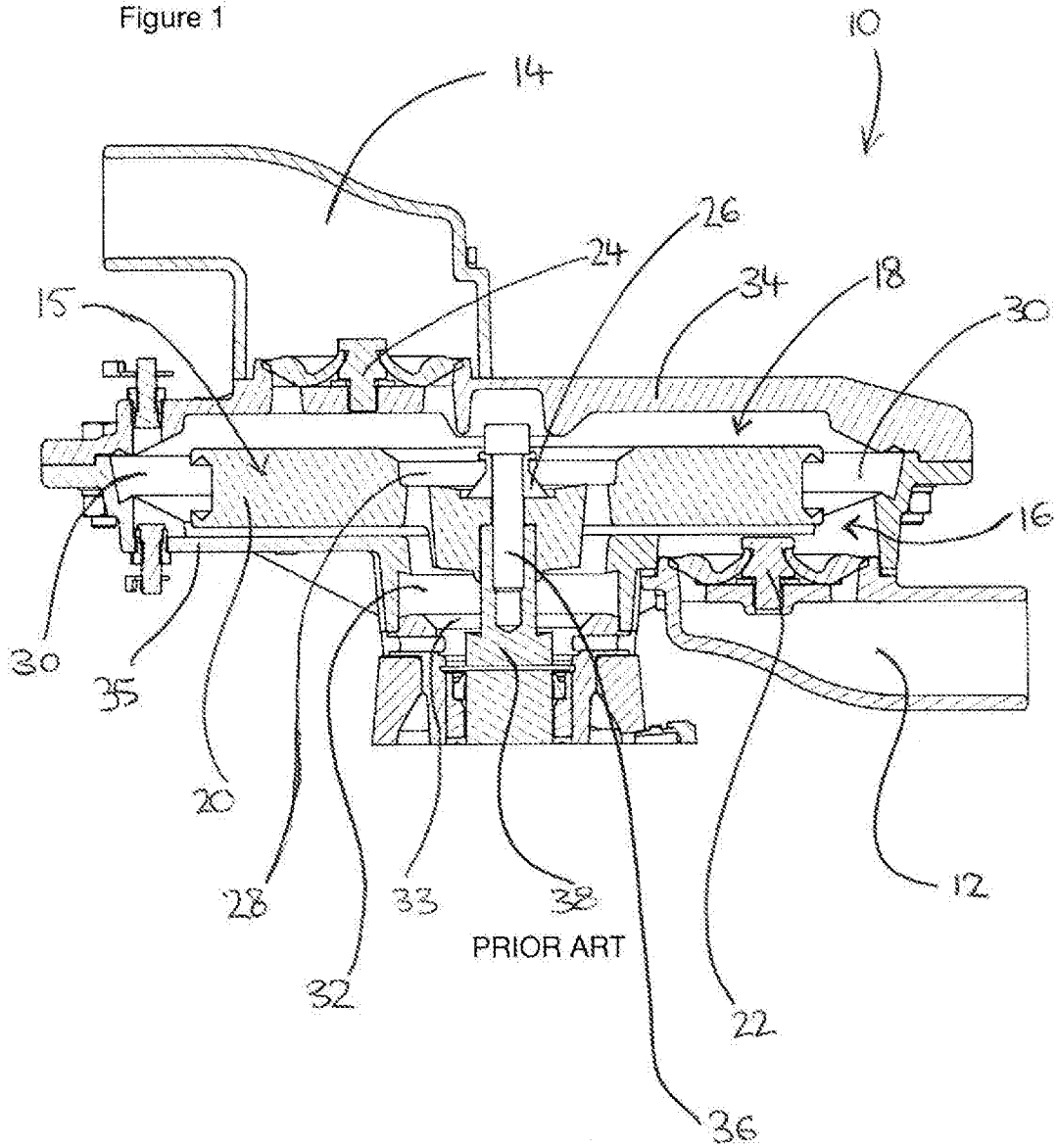

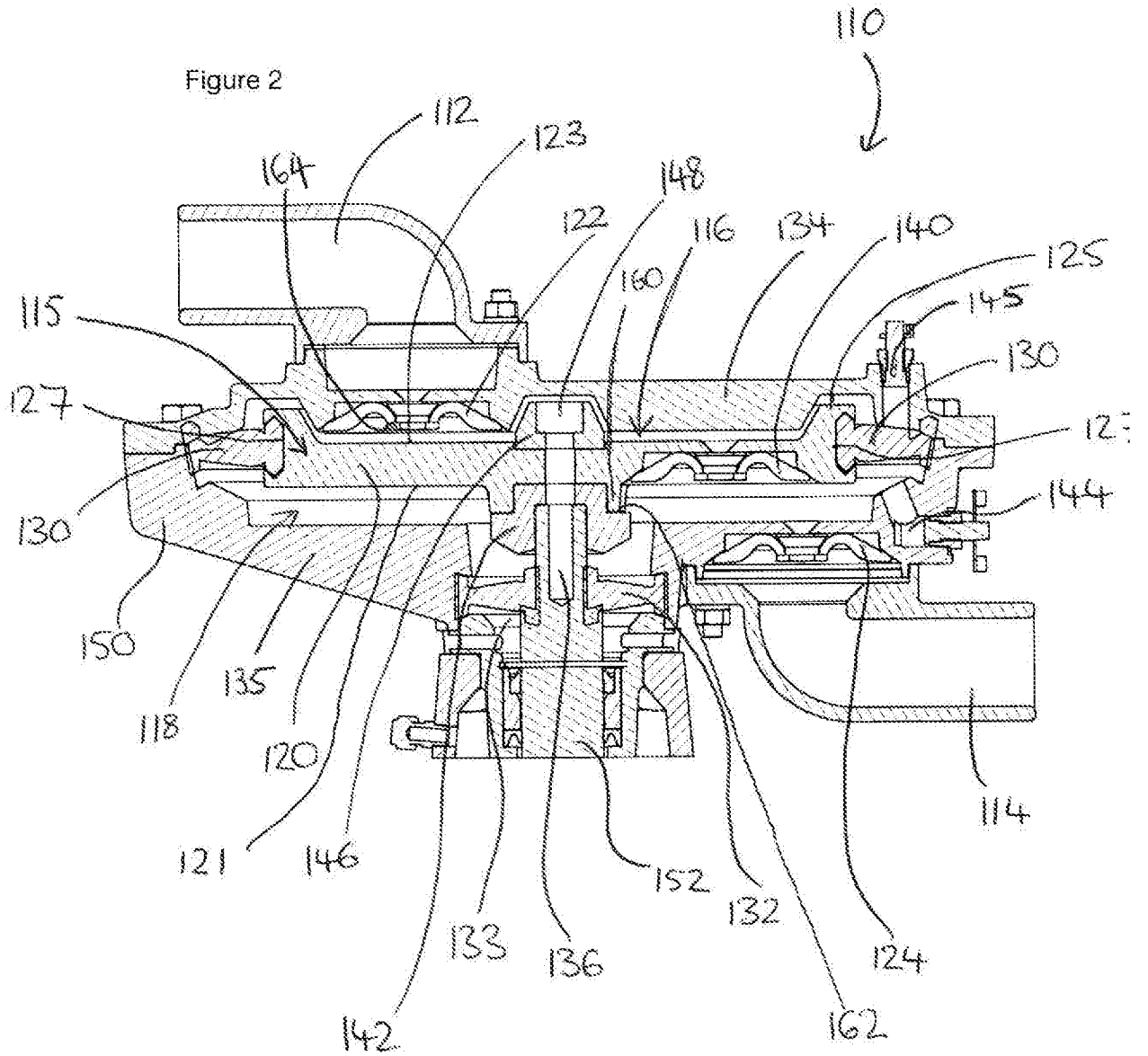

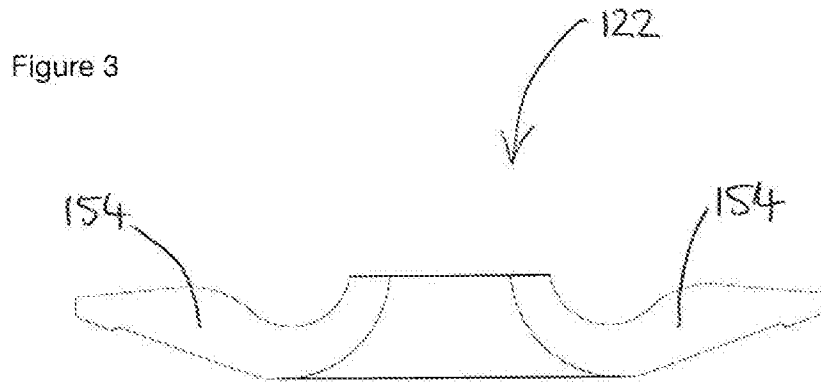

Figure 4

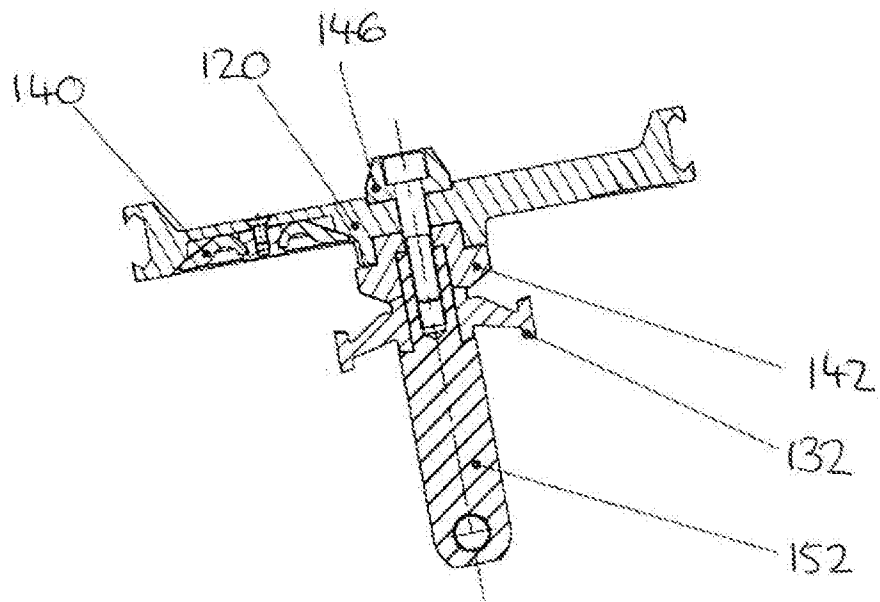

Figure 5

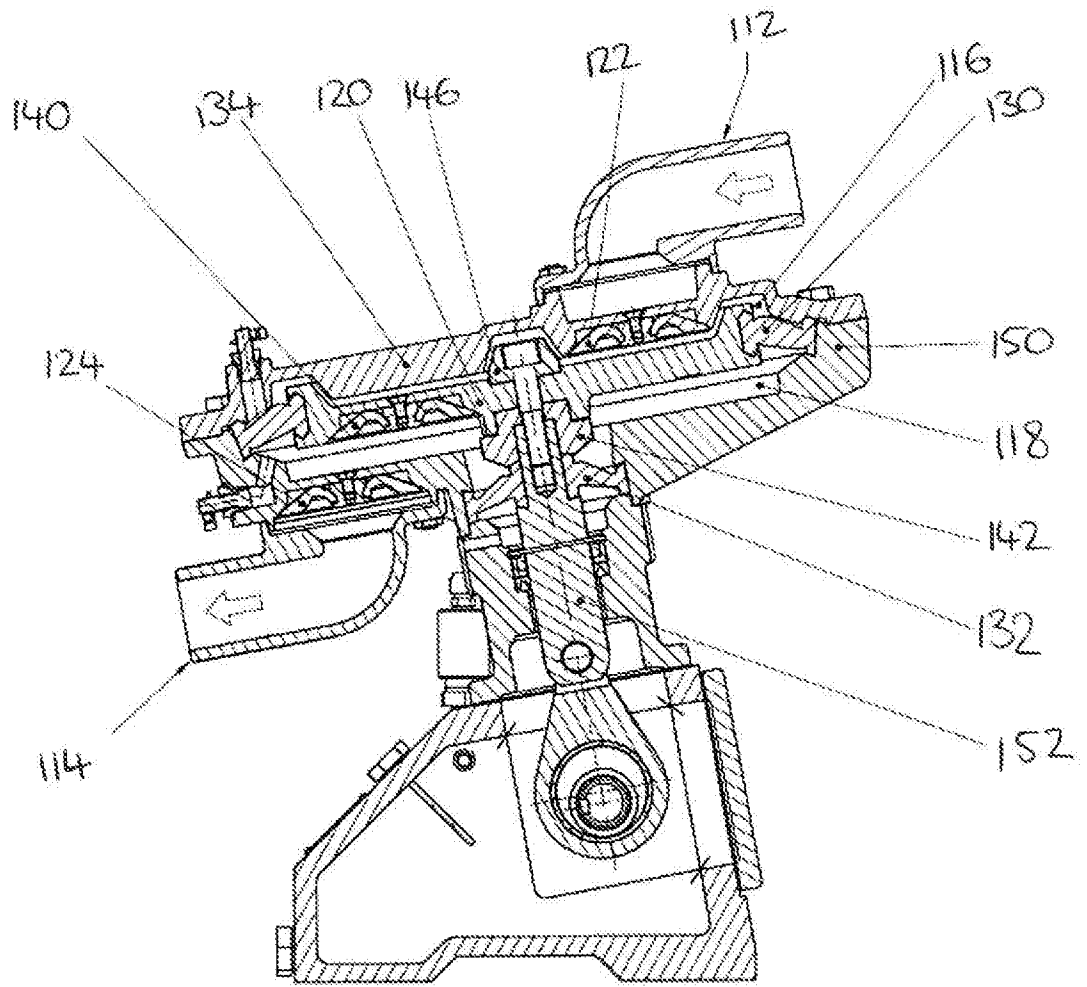
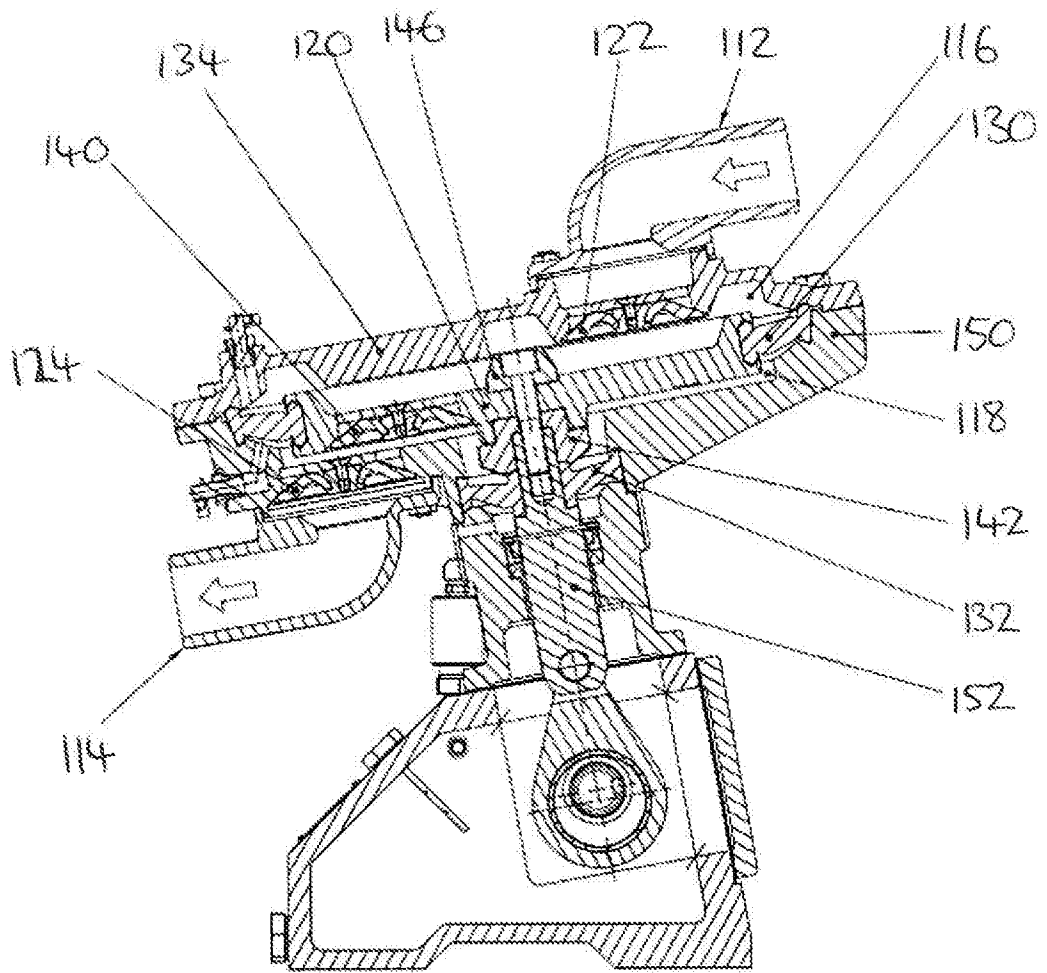

Figure 6.



INTERNATIONAL SEARCH REPORT

International application No
PCT/GB2013/051004

A. CLASSIFICATION OF SUBJECT MATTER
INV. F04B45/04
ADD.
According to International Patent Classification (IPC) or to both national classification and IPC

B. FIELDS SEARCHED
Minimum documentation searched (classification system followed by classification symbols)
F04B

Documentation searched other than minimum documentation to the extent that such documents are included in the fields searched

Electronic data base consulted during the international search (name of data base and, where practicable, search terms used)
EPO-Internal, WPI Data

C. DOCUMENTS CONSIDERED TO BE RELEVANT

Category*	Citation of document, with indication, where appropriate, of the relevant passages	Relevant to claim No.
X	GB 2 388 163 A (MARSHALL DAVID R [GB]) 5 November 2003 (2003-11-05) page 3, line 26 page 10, line 20 - page 12, line 10 -----	1-3,5-9, 19-24
X	EP 0 032 473 A1 (ETA SA [FR]) 22 July 1981 (1981-07-22) page 3 - page 6; figures 1,2 -----	1-3,5-9
A	EP 0 144 609 A2 (MITSUBISHI ELECTRIC CORP [JP]) 19 June 1985 (1985-06-19) figures 1,2 -----	4,10-18

Further documents are listed in the continuation of Box C.

See patent family annex.

* Special categories of cited documents :

- "A" document defining the general state of the art which is not considered to be of particular relevance
- "E" earlier application or patent but published on or after the international filing date
- "L" document which may throw doubts on priority claim(s) or which is cited to establish the publication date of another citation or other special reason (as specified)
- "O" document referring to an oral disclosure, use, exhibition or other means
- "P" document published prior to the international filing date but later than the priority date claimed

- "T" later document published after the international filing date or priority date and not in conflict with the application but cited to understand the principle or theory underlying the invention
- "X" document of particular relevance; the claimed invention cannot be considered novel or cannot be considered to involve an inventive step when the document is taken alone
- "Y" document of particular relevance; the claimed invention cannot be considered to involve an inventive step when the document is combined with one or more other such documents, such combination being obvious to a person skilled in the art
- "&" document member of the same patent family

Date of the actual completion of the international search
8 July 2013

Date of mailing of the international search report
16/07/2013

Name and mailing address of the ISA/
European Patent Office, P.B. 5818 Patentlaan 2
NL - 2280 HV Rijswijk
Tel. (+31-70) 340-2040,
Fax: (+31-70) 340-3016

Authorized officer
Ziegler, Hans-Jürgen

INTERNATIONAL SEARCH REPORT

International application No.
PCT/GB2013/051004

Box No. II Observations where certain claims were found unsearchable (Continuation of item 2 of first sheet)

This international search report has not been established in respect of certain claims under Article 17(2)(a) for the following reasons:

1. Claims Nos.:
because they relate to subject matter not required to be searched by this Authority, namely:

2. Claims Nos.:
because they relate to parts of the international application that do not comply with the prescribed requirements to such an extent that no meaningful international search can be carried out, specifically:

3. Claims Nos.:
because they are dependent claims and are not drafted in accordance with the second and third sentences of Rule 6.4(a).

Box No. III Observations where unity of invention is lacking (Continuation of item 3 of first sheet)

This International Searching Authority found multiple inventions in this international application, as follows:

see additional sheet

1. As all required additional search fees were timely paid by the applicant, this international search report covers all searchable claims.
2. As all searchable claims could be searched without effort justifying an additional fees, this Authority did not invite payment of additional fees.
3. As only some of the required additional search fees were timely paid by the applicant, this international search report covers only those claims for which fees were paid, specifically claims Nos.:
4. No required additional search fees were timely paid by the applicant. Consequently, this international search report is restricted to the invention first mentioned in the claims; it is covered by claims Nos.:

Remark on Protest

- The additional search fees were accompanied by the applicant's protest and, where applicable, the payment of a protest fee.
- The additional search fees were accompanied by the applicant's protest but the applicable protest fee was not paid within the time limit specified in the invitation.
- No protest accompanied the payment of additional search fees.

FURTHER INFORMATION CONTINUED FROM PCT/ISA/ 210

This International Searching Authority found multiple (groups of) inventions in this international application, as follows:

1. claims: 1-4

Double acting diaphragm pump with a drive member seal.

2. claims: 5-10

Double acting diaphragm pump with valve in piston member at a position radially spaced from central axis.

3. claims: 11-18(completely); 4, 10(partially)

Diaphragm pump with connection arrangement between piston and drive member.

INTERNATIONAL SEARCH REPORT

Information on patent family members

International application No

PCT/GB2013/051004

Patent document cited in search report	Publication date	Patent family member(s)	Publication date
GB 2388163	A	05-11-2003	NONE

EP 0032473	A1	22-07-1981	DE 3164624 D1 16-08-1984
			EP 0032473 A1 22-07-1981
			FR 2473646 A1 17-07-1981

EP 0144609	A2	19-06-1985	EP 0144609 A2 19-06-1985
			JP S6066883 U 11-05-1985
