



(86) Date de dépôt PCT/PCT Filing Date: 2009/09/10
 (87) Date publication PCT/PCT Publication Date: 2010/03/25
 (85) Entrée phase nationale/National Entry: 2011/03/17
 (86) N° demande PCT/PCT Application No.: JP 2009/065873
 (87) N° publication PCT/PCT Publication No.: 2010/032682
 (30) Priorité/Priority: 2008/09/18 (JP2008-239680)

(51) Cl.Int./Int.Cl. *H02H 3/06* (2006.01),
H02H 3/28 (2006.01)
 (71) Demandeur/Applicant:
KABUSHIKI KAISHA TOSHIBA, JP
 (72) Inventeurs/Inventors:
IINUMA, SHIGEO, JP;
HORI, MASAO, JP;
SHINSYOU, SATOSHI, JP
 (74) Agent: RIDOUT & MAYBEE LLP

(54) Titre : PROCÉDE DE REENCLANCHÉMENT POUR LIGNE DE TRANSPORT D'ENERGIE ELECTRIQUE
 (54) Title: RECLOSING SYSTEM FOR POWER TRANSMISSION LINE

[圖4]

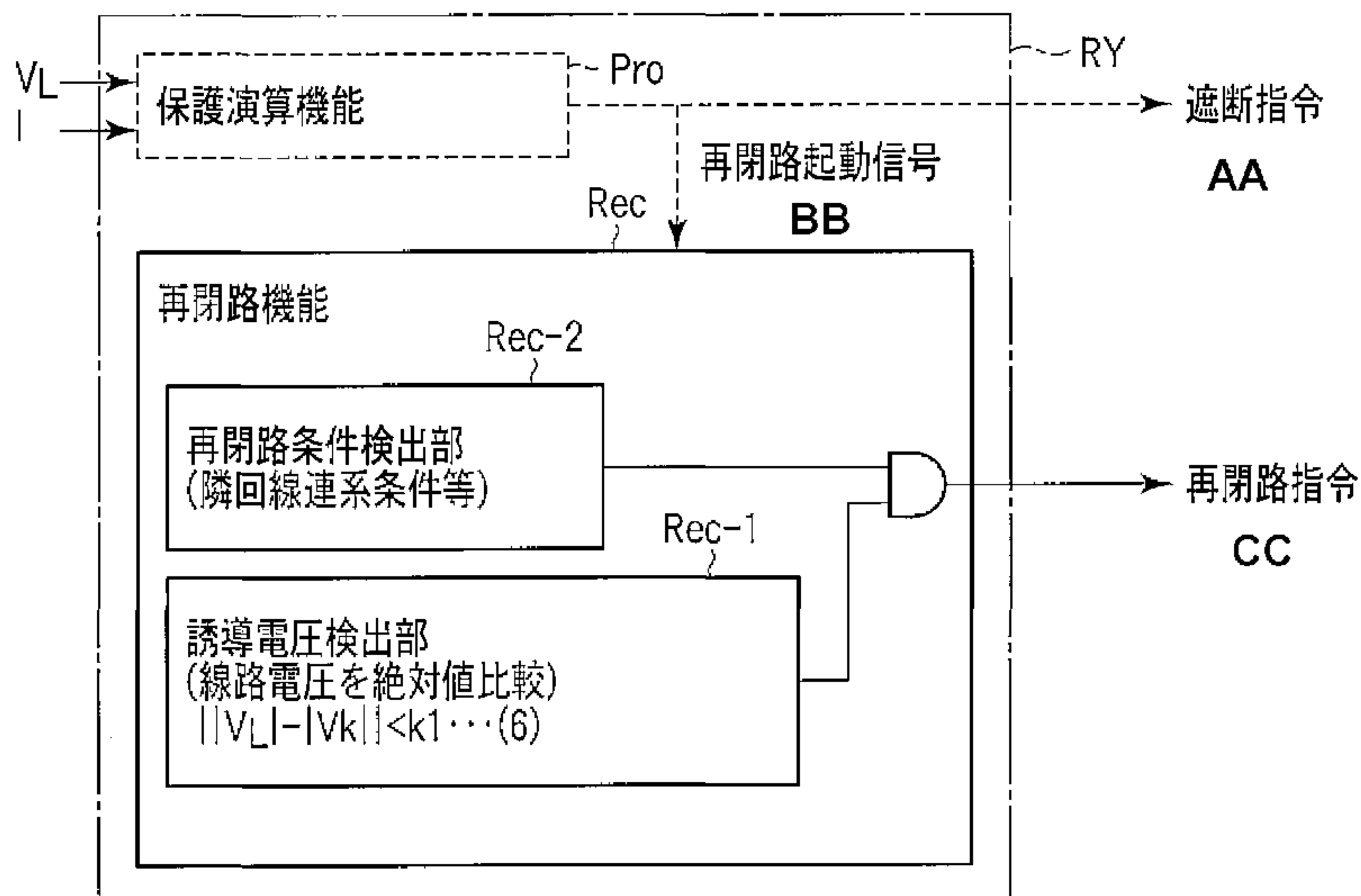

- AA Interrupt command
- BB Reclose startup signal
- CC Reclose command
- Pro Protection calculation function
- Rec Reclose function
- Rec-1 Induction voltage detection unit (comparison of absolute values of line voltages)
- Rec-2 Reclose condition detection unit (interconnection condition of adjacent lines, etc.)

(57) Abrégé/Abstract:

Disclosed is a reclosing method for an electrical power transmission line with which reclosing is performed at high speed by means of a protective relay (RY) that is equipped with a protection calculation function (Pro), whereby a faulty phase of the electrical power

(57) **Abrégé(suite)/Abstract(continued):**

transmission line is interrupted by means of a prescribed protection calculation in which a voltage signal (V_L) and a current signal (I) that are detected at each terminal of the electrical power transmission line are input, and a reclosing function (Rec) whereby a "reclose" command is output to the breaker of a terminal when a reclosing condition is met with respect to a faulty phase that has been interrupted, wherein a "startup" command is transmitted to the breaker that has interrupted the faulty phase when the line voltage value (V_L) of the faulty phase that is detected at the terminal after the fault interruption is within a permissible range ($||V_L - V_k|| < k1$) that is determined by the line voltage value (V_k) when the faulty phase is sound for release.

(12) 特許協力条約に基づいて公開された国際出願

(19) 世界知的所有権機関
国際事務局



(10) 国際公開番号

WO 2010/032682 A1

(43) 国際公開日
2010年3月25日(25.03.2010)

- (51) 国際特許分類:
H02H 3/06 (2006.01) H02H 3/28 (2006.01)
 - (21) 国際出願番号: PCT/JP2009/065873
 - (22) 国際出願日: 2009年9月10日(10.09.2009)
 - (25) 国際出願の言語: 日本語
 - (26) 国際公開の言語: 日本語
 - (30) 優先権データ:
特願 2008-239680 2008年9月18日(18.09.2008) JP
 - (71) 出願人 (米国を除く全ての指定国について): 株式会社 東芝 (KABUSHIKI KAISHA TOSHIBA) [JP/JP]; 〒1058001 東京都港区芝浦一丁目1番1号 Tokyo (JP).
 - (72) 発明者; および
 - (75) 発明者/出願人 (米国についてのみ): 飯沼 繁雄 (IINUMA, Shigeo) [JP/JP]. 堀 政夫 (HORI, Masao) [JP/JP]. 新庄 敏 (SHINSYOU, Satoshi) [JP/JP].
 - (74) 代理人: 鈴江 武彦, 外 (SUZUYE, Takehiko et al.); 〒1050001 東京都港区虎ノ門1丁目12番9号 鈴榮特許総合事務所内 Tokyo (JP).
 - (81) 指定国 (表示のない限り、全ての種類の国内保護が可能): AE, AG, AL, AM, AO, AT, AU, AZ, BA, BB, BG, BH, BR, BW, BY, BZ, CA, CH, CL, CN, CO, CR, CU, CZ, DE, DK, DM, DO, DZ, EC, EE, EG, ES, FI, GB, GD, GE, GH, GM, GT, HN, HR, HU, ID, IL, IN, IS, KE, KG, KM, KN, KP, KR, KZ, LA, LC, LK, LR, LS, LT, LU, LY, MA, MD, ME, MG, MK, MN, MW, MX, MY, MZ, NA, NG, NI, NO, NZ, OM, PE, PG, PH, PL, PT, RO, RS, RU, SC, SD, SE, SG, SK, SL, SM, ST, SV, SY, TJ, TM, TN, TR, TT, TZ, UA, UG, US, UZ, VC, VN, ZA, ZM, ZW.
 - (84) 指定国 (表示のない限り、全ての種類の広域保護が可能): ARIPO (BW, GH, GM, KE, LS, MW, MZ, NA, SD, SL, SZ, TZ, UG, ZM, ZW), ユーラシア (AM, AZ, BY, KG, KZ, MD, RU, TJ, TM), ヨーロッパ (AT, BE, BG, CH, CY, CZ, DE, DK, EE, ES, FI, FR, GB, GR, HR, HU, IE, IS, IT, LT, LU, LV, MC, MK, MT, NL, NO, PL, PT, RO, SE, SI, SK, SM, TR), OAPI (BF, BJ, CF, CG, CI, CM, GA, GN, GQ, GW, ML, MR, NE, SN, TD, TG).
- 添付公開書類:
— 国際調査報告 (条約第 21 条(3))

(54) Title: RECLOSING METHOD FOR ELECTRICAL POWER TRANSMISSION LINE

(54) 発明の名称: 送電線路の再閉路方式

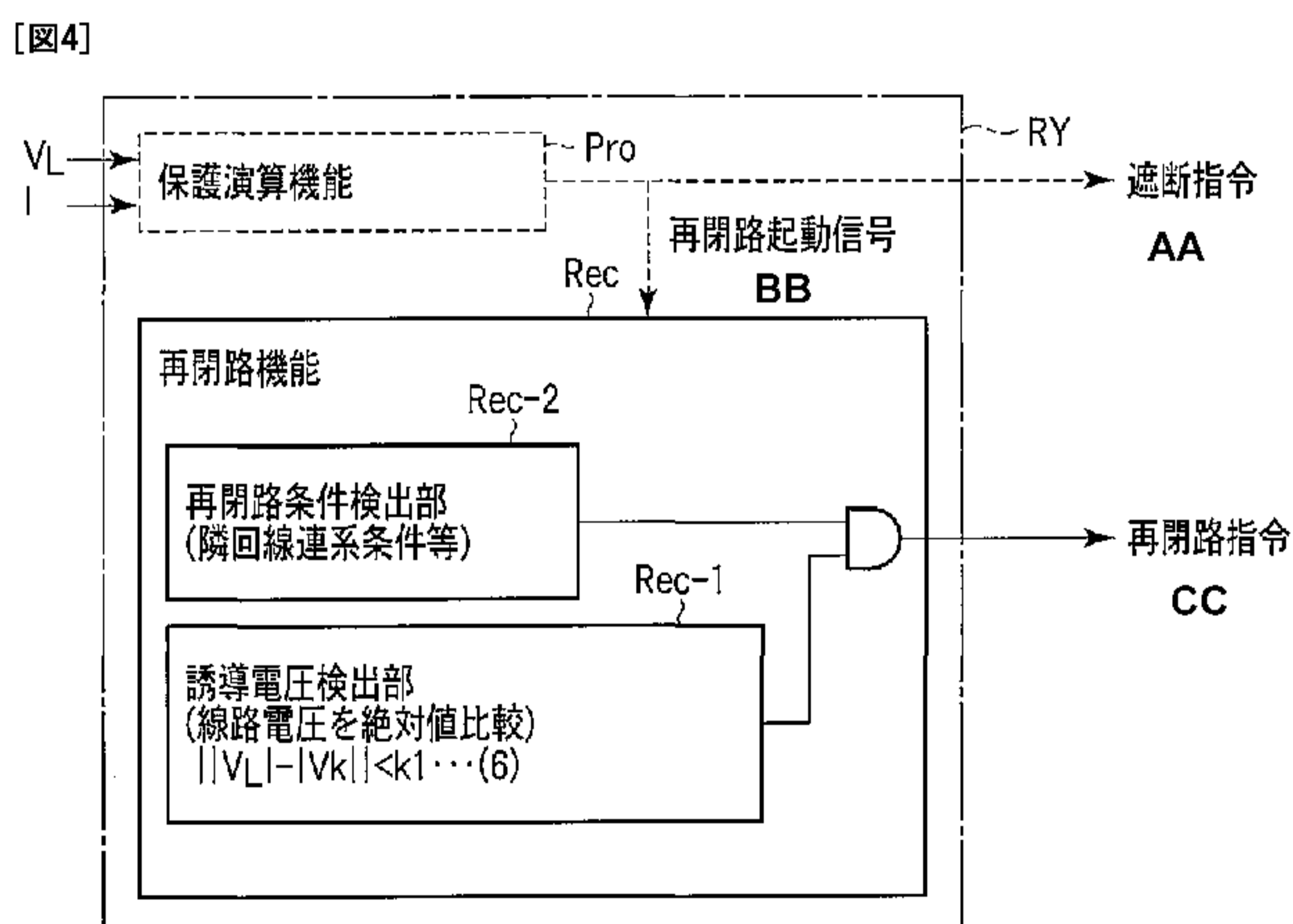

- AA Interrupt command
- BB Reclose startup signal
- CC Reclose command
- Pro Protection calculation function
- Rec Reclose function
- Rec-1 Induction voltage detection unit (comparison of absolute values of line voltages)
- Rec-2 Reclose condition detection unit (interconnection condition of adjacent lines, etc.)

(57) Abstract: Disclosed is a reclosing method for an electrical power transmission line with which reclosing is performed at high speed by means of a protective relay (RY) that is equipped with a protection calculation function (Pro), whereby a faulty phase of the electrical power transmission line is interrupted by means of a prescribed protection calculation in which a voltage signal (V_L) and a current signal (I) that are detected at each terminal of the electrical power transmission line are input, and a reclosing function (Rec) whereby a "reclose" command is output to the breaker of a terminal when a reclosing condition is met with respect to a faulty phase that has been interrupted, wherein a "startup" command is transmitted to the breaker that has interrupted the faulty phase when the line voltage value (V_L) of the faulty phase that is detected at the terminal after the fault interruption is within a permissible range ($||V_L| - |V_k|| < k1$) that is determined by the line voltage value (V_k) when the faulty phase is sound for release.

(57) 要約: 送電線路の各端子で検出した電圧信号 V_L および電流信号 I を入力して所定の保護演算を行うことにより送電線路の事故相を遮断する保護演算機能 (Pro) および当該事故遮断相に再閉路条件が整った

たときに自端子の遮断器に再閉路指令を出力する再閉路機能 (Rec) を備えた保護リレー (RY) により高速再閉路を行うようにした送電線路の再閉路方式において、自端子で検出された事故遮断後の事故相の線路電圧の値 V_L が、事故相の開放健全時の線路電圧値 V_k で定めた許容範囲 ($||V_L| - |V_k|| < k1$) に存在するとき、事故相遮断器に投入指令を送出する。

WO 2010/032682 A1

D E S C R I P T I O N

RECLOSING SYSTEM FOR POWER TRANSMISSION LINE

5

Technical Field

The present invention relates to a reclosing system for a power transmission line, in which the arc ion extinguishing time of an accident phase is detected by a simple method to execute reclosing.

10

Background Art

There is a reclosing system of a direct grounding type for power transmission lines. As the reclosing system of this type, a single-phase reclosing system in which when there is one accident phase, only the accident phase is opened and reclosed, or a three-phase reclosing system in which when there are two accident phases, three phases are opened and reclosed, is employed. Further, there is a parallel-type double-line reclosing system. As the parallel double-line reclosing system, a multiphase reclosing system, in which an accident phase is opened, and is reclosed if two or three normal phases are still left, is employed for stable operation.

25

In general, the time ranging from the opening of a circuit breaker to its reclosing is called a no-voltage time period. The no-voltage time period is determined based on a supposed time period ranging from the cutoff

of an accident current by the circuit breaker, to the
arc-ion extinguished time point at the place of the
accident. The no-voltage time period varies depending
upon the state of the accident. In the single-phase
5 and multiphase reclosing systems, the no-voltage time
period is set to about 1 sec, while in the three-phase
reclosing system, it is set to about 0.5 to 0.8 sec.

FIG. 19 is a time chart illustrating the operation
performed from the opening of a circuit breaker CB by a
10 transmission line protection relay RY to the reclosing
of the breaker by the relay after a no-voltage time
elapses, when an accident F due to, for example, ground
discharge occurs in a single-line power transmission
line TL. (a), (b) and (c) of FIG. 19 show the
15 operation of a power system, the response of the
circuit breaker CB, and the response of the protection
relay RY, respectively.

As shown in (a), (b) and (c) of FIG. 19, the
accident F occurs at time point t_1 due to, for example,
20 ground discharge, an accident current flows into the
transmission line protection relay RY to operate the
same, the relay RY outputs a cutoff command to the
circuit breaker CB at time point t_2 , and the circuit
breaker CB is opened at time point t_3 to extinguish the
25 accident current.

At the place of the accident F, the ambient air is
ionized by arc discharge. If power transmission is

resumed before arc ions are diffused and extinguished, arc current again flows and reclosing fails. In view of this, time point t_4 ($< t_5$) at which a reclosing command is issued is set so that the circuit breaker CB is reclosed at time point t_5 assumed after a time period within which the arc ions are generally supposed to be completely extinguished elapses.

The time period (ion extinguishing time period) required until the arc ions are extinguished after the accident current is cut off varies depending upon primary arc current, system voltage, line constant length (on which line distributed capacity depends), wind velocity, etc. At any rate, it is necessary to set the no-voltage time period up to reclosing slightly longer than the ion extinguishing time period.

In general, the dielectric recovery time period and the ion extinguishing time period are longer as the accident current is greater and in proportion to the system voltage. The no-voltage time period for reclosing is set to about 1.0 sec. in the case of a 500 kV system, and to about 0.5 to 0.8 sec. in the case of a 187 to 275 kV system.

FIG. 20 is a graph showing the relationship between the nominal voltage and the time period required for ion extinguishing after cutoff due to an accident, which is assumed where the accident current is about 20 kA. At the accident place F, the air is

ionized by arc discharge, and residual ions are left even after the accident current is cut off. The time period within which the residual ions are extinguished, i.e., the ion extinguishing time period, is deeply associated with the system voltage. Namely, the higher the system voltage, the longer the ion extinguishing time period.

For the power system, the no-voltage time period for reclosing significantly influences its stability. Therefore, it is preferable to minimize the no-voltage time period. To this end, Japanese Patent No. 3710771, for example, has proposed a technique of detecting the time when the ratio of harmonics in the line voltage of an accident cutoff phase is reduced (this time period corresponding to the arc-ion extinguishing time period), and adaptively (freely) changing the no-voltage time period based on the detection result.

Disclosure of Invention

In the proposed technique, it is necessary to detect line voltage changes ranging from substantially 0 V at the time of occurrence of an accident to the voltage resulting from the induction caused after extinguishing of the arc ions. Namely, an extremely high detection accuracy is required. In particular, since the voltage assumed before the arc ions are extinguished, i.e., a line voltage at a corresponding terminal, significantly differs depending upon the

position of an accident on the power transmission line, highly accurate voltage detection must be performed.

If the arc ion extinguishing time can be detected and a reclosing command is issued at the detection time period, occurrence of an accident during reclosing can be avoided and hence the system is much stabilized. However, as described above, highly accurate voltage detection is required to detect the arc ion extinguishing time. Because of this, it is difficult at present to put to practice the method disclosed in the above-mentioned publication.

Accordingly, it is an object of the present invention to provide a reclosing system for power transmission lines, which does not require so high line voltage detection accuracy, can easily detect the arc ion extinguishing time of an accident phase, and can prevent occurrence of an accident during reclosing.

According to one aspect of the present invention, there is provided a reclosing system for a power transmission line, which performs high-speed reclosing using protection relays, the protection relays being provided at different terminals of the power transmission line, each of the protection relays comprising a protection calculation function and a reclosing function, the protection calculation function being configured to receive voltage signals detected by a metering voltage transformer and current signals

detected by a metering current transformer to execute a predetermined protection calculation to thereby cut off a phase with an accident on the power transmission line, the reclosing function being configured to output a reclosing command to a circuit breaker when the phase with the accident becomes to satisfy a reclosing condition, wherein each of the protection relays comprises means for sending the reclosing command to the circuit breaker when a line voltage at the phase with the accident, detected by the metering voltage transformer after the phase with the accident is cut off, falls within an allowable range, the allowable range being determined based on a line voltage assumed at the phase when the phase is normal.

According to another aspect of the present invention, there is provided a reclosing system for a power transmission line, which performs high-speed reclosing using protection relays, the protection relays being provided at different terminals of the power transmission line, each of the protection relays comprising a protection calculation function and a reclosing function, the protection calculation function being configured to receive voltage signals detected by a metering voltage transformer and current signals detected by a metering current transformer to execute a predetermined protection calculation to thereby cut off a phase with an accident on the power transmission

line, the reclosing function being configured to output a reclosing command to a circuit breaker when the phase with the accident becomes to satisfy a reclosing condition, wherein that each of the protection relays comprises means for sending the reclosing command to the circuit breaker when a line voltage at the phase with the accident, detected by the metering voltage transformer after the phase with the accident is cut off, falls within an allowable range, the allowable range being determined based on a line voltage calculated for the phase assuming that the phase is normal, the calculated line voltage being acquired based on a current and a voltage at a normal phase of the power transmission line.

According to the present invention, it is possible to provide a reclosing system for power transmission lines, which does not require so high line voltage detection accuracy, can easily detect the arc ion extinguishing time of an accident phase, and can prevent occurrence of an accident during reclosing.

Brief Description of Drawings

FIG. 1 is a view illustrating a power system provided with protection relays having a reclosing function, which system is employed in common in first and second embodiments;

FIG. 2 is a block diagram illustrating each protection relay with the reclosing function, employed

in common in the first and second embodiments;

FIG. 3 is a view illustrating a voltage induced during single phase reclosing (a-phase is cut off), (a) of FIG. 3 illustrating a voltage resulting from electrostatic coupling, and (b) of FIG. 3 illustrating a voltage resulting from electromagnetic coupling;

5

FIG. 4 is a block diagram illustrating an example employed in the first embodiment, in which a line voltage is detected by absolute value comparison;

10

FIG. 5 is a flowchart useful in explaining the operation of the first embodiment;

FIG. 6 is a view useful in explaining the concept of a reclosing allowable range employed in the first embodiment;

15

FIG. 7 is a block diagram illustrating another example employed in the first embodiment, in which a line voltage is detected using a ratio;

FIG. 8 is a flowchart useful in explaining the operation of a second embodiment;

20

FIG. 9 is a circuit diagram illustrating a power system with a reclosing function shared between third to fifth embodiments of the present invention;

FIG. 10 is a block diagram illustrating the power system with the reclosing function shared between the third to sixth embodiments of the present invention;

25

FIG. 11 is a flowchart useful in explaining the operation of a third embodiment of the present

invention;

FIG. 12 is a flowchart useful in explaining the operation of a fourth embodiment of the present invention;

5 FIG. 13 is a flowchart useful in explaining the operation of a fifth embodiment of the present invention;

10 FIG. 14 is a flowchart useful in explaining the operation of a sixth embodiment of the present invention;

FIG. 15 is a block diagram illustrating a power system with a reclosing function according to a seventh embodiment of the present invention;

15 FIG. 16 is a view useful in explaining a phase allowable range set for an induced voltage;

FIG. 17 is a flowchart useful in explaining the operation of the seventh embodiment of the present invention;

20 FIG. 18 is a flowchart useful in explaining the operation of an eighth embodiment of the present invention;

25 FIG. 19 is a view useful in explaining a conventional power transmission line, (a) of FIG. 19 illustrating a power system as a reclosing target, (b) of FIG. 19 illustrating a breaker operation timing chart useful in explaining a no-voltage time period, and (c) of FIG. 19 illustrating a protection relay

operation timing chart; and

FIG. 20 is a graph illustrating the relationship between the system voltage and the insulated-state restoring time period.

5 Mode for Carrying Out the Invention

Embodiments of the present invention will be described with reference to the accompanying drawings. In the embodiments, like reference numbers denote like elements, and no duplicate descriptions will be given.

10 [First Embodiment]

Referring first to FIGS. 1 to 3, a first embodiment of the present invention will be described.

The first embodiment is directed to a reclosing system for power transmission lines, in which a reclosing command is output to an accident-phase cutoff breaker when, for example, adjacent line linkage conditions are met, and when the line voltage of an accident phase assumed after cutoff by the circuit breaker substantially reaches a predetermined value.

20 (Structure)

FIG. 1 is a view illustrating a power system that includes protection relays RY having a reclosing function and provided at opposing terminals A and B. The reclosing function is used to determine whether reclosing can be executed using only a line voltage signal V_L detected by each metering voltage transformer VT_L . FIG. 2 is a block diagram illustrating an example

of the protection relay RY having the reclosing function.

At the terminals A and B of the power system shown in FIG. 1, circuit breakers CB-A and CB-B are provided for connecting bus lines BUS-A and BUS-B to power transmission lines TL. Further, metering current transformers CT-A and CT-B are provided on the bus lines BUS-A and BUS-B for detecting line currents i , and metering voltage transformers VT_L -A and VT_L -B are provided on the power transmission line TL for detecting line voltages V_L .

Since the protection relays RY-A and RY-B with the reclosing function have the same structure and function, a description will now be given only of the protection relay RY-A.

As shown in FIG. 2, the protection relay RY-A incorporates a protection calculation function Pro for constantly reading line currents I and line voltages V_L from the current transformers CT-A and the voltage transformers VT_L -A, respectively, constantly executing calculations on the read currents I and line voltages V_L using predetermined protection calculation algorithms, and outputting a cutoff command to a circuit breaker CB-A to cut off the place of an accident F when detecting the accident F in the corresponding power transmission line TL as a result of the calculations. The protection relay RY-A also

incorporates a reclosing function Rec for outputting a reclosing command to the circuit breaker CB-A when the line voltage of the accident phase measured after the cutoff of the accident place falls within a
5 predetermined allowable range. When the protection operation function Pro operates, it outputs a cutoff command to the circuit breaker CB-A as described above, and also outputs a reclosing start signal to the reclosing function Rec. The protection operation
10 function Pro is, for example, a current differential relay for protection. Further, the reclosing function Rec is also called a reclosing relay.

Returning to FIG. 1, when an accident F occurs in the a-phase power transmission line TL, a cutoff
15 command is output from the protection operation function Pro of the protection relay RY-A to the a-phase breaker, thereby executing cutoff of the a-phase power transmission line TL. At this time, after arc
ions are extinguished at the accident place F, the b-
20 and c-phase power transmission lines, which are kept normal, induce a voltage at the a-phase power transmission line that assumes an open state, as will be described referring to FIG. 3.

(a) and (b) of FIG. 3 are views useful in
25 explaining the voltage induced at the a-phase line of a single-line power transmission cable by the normal b- and c-phase lines of the power transmission cable when

the a-phase is cut off. More specifically, (a) of FIG. 3 shows an example of electrostatic coupling occurring between the a-phase and the normal b-phase and between the a-phase and the normal c-phase. (b) of FIG. 3 shows an example of electromagnetic induction coupling occurring between the a-phase and the normal b-phase and between the a-phase and the normal c-phase.

Referring first to (a) of FIG. 3, a description will be given of calculation of a voltage induced at the a-phase by the normal b- and c-phases when an accident occurs in the a-phase and hence the a-phase is opened.

Assuming that C_m represents an interphase electrostatic capacitance that occurs between power transmission lines due to electrostatic coupling, and C_s represents an earth electrostatic capacitance, the current given by the following equation (1) flows into the a-phase:

$$j\omega C_m (V_b - V_a) + j\omega C_m (V_c - V_a) = j\omega C_s V_a \quad \dots (1)$$

where $j\omega C_m (V_b - V_a)$ represents a current flowing from the b-phase through the interphase capacitance C_m , $j\omega C_m (V_c - V_a)$ represents a current flowing from the c-phase through the interphase capacitance C_m . As a result, the current $j\omega C_s V_a$ as the synthesized current of $j\omega C_m (V_b - V_a)$ and $j\omega C_m (V_c - V_a)$ flows through the a-phase to the earth via the earth electrostatic capacitance C_s .

From the equation (1), the voltage sVa expressed by the following equation (2) is derived:

$$sVa = \frac{Cm}{(2Cm+Cs)}(Vb+c) \quad \dots (2)$$

5

On the other hand, in (b) of FIG. 3, assuming that the mutual impedance occurring between lines due to electromagnetic coupling is M , the voltage mVa given by the following equation (3) occurs at the a-phase in the open state:

10

$$mVa = j\omega M(Ib + Ic) \quad \dots (3)$$

As a result, a voltage ($sVa + mVa$) obtained by combining the electrostatic coupling voltage sVa and the electromagnetic coupling voltage mVa occurs at the a-phase that is open because of the accident.

15

Note that in order to avoid complication in drawing and numerical expression, (b) of FIG. 3 does not show Cs , Cm , and M to be associated with a-phase, b-phase, and c-phase although it is desirable to show as such.

20

The electrostatic coupling voltage sVa shown in FIG. 3 is not associated with the place of an accident, and the following equation (4) is satisfied, which means that the higher the power transmission voltage E and the greater the interline capacitance Cm compared to the ground electrostatic capacitance Cs , the greater the electrostatic coupling voltage sVa .

25

$$Vc = CmE / (Cs + 2Cm) \quad \dots (4)$$

E: Rated phase voltage of the system

Further, the electromagnetic coupling voltage mV_a is induced at the phase that assumes the open state, as is given by the equation (3).

5 An arc current I_C caused by the electromagnetic coupling voltage is given by the following equation (5):

$$I_c = j\omega C_m \cdot L(V_b + V_c) \quad \dots (5)$$

L: Line length

10 A voltage V_k is beforehand calculated using the above equation (4), and the currents I and voltages V_L , which are respectively introduced from the current transformers CT-A and voltage transformers VT_L -A located across the b- and c-phase power transmission
15 lines when the a-phase power transmission line is normal before it is opened because of the accident. The thus-calculated voltage V_k corresponds to the induced voltage ($sV_a + mV_a$) and is stored in the memory means of the protection relay RY-A with the reclosing
20 function.

Table 1 shows induced voltages α beforehand calculated by classifying, into three ranks (large, mean and small), the currents flowing through normal lines with one of the lines opened.

Table 1

	Line voltage calculation results		
	Current: large	Current: mean	Current: small
When a-phase is open	$\alpha a 1$	$\alpha a 2$	$\alpha a 3$
When b-phase is open	$\alpha b 1$	$\alpha b 2$	$\alpha b 3$
When c-phase is open	$\alpha c 1$	$\alpha c 2$	$\alpha c 3$

α : Induced voltage at each open phase for each current level

Example of data table for single- or multi-line power transmission cable

5

In table 1, "Current: large" corresponds to 100% of the rated current of the power transmission line, "Current: mean" corresponds to 50% of the rated current, and "Current: small" corresponds to about 10% of the rated current. In addition to this, data corresponding to various open phases of a double-line transmission cable is prepared.

10

(First Example of Reclosing Function Rec)

FIG. 4 shows a structure example of the reclosing function Rec of the protection relay RY. The induced-voltage detector Rec-1 employed in this example executes detection using absolute value comparison.

15

Namely, the induced-voltage detector Rec-1 having the reclosing function Rec acquires the absolute value $(||V_L| - |V_k||)$ of the difference between the absolute value $(|V_L|)$ of the measured line voltage V_L induced at, for example, the a-phase opened upon occurrence of an

20

accident, and the absolute value ($|V_k|$) of the line
voltage V_k beforehand calculated when the power
transmission lines are all normal, and compares the
acquired absolute value with an allowance constant k_1
5 beforehand calculated for reclosing (numerical
expression (6)). If the calculation result of the
induced-voltage detector Rec-1 that the difference with
respect to a predetermined value (induced voltage V_k)
is determined to fall with a preset range set in view
10 of errors in the measured value, calculated value, the
values of the current transformers CT, the voltage
transformers VT_L , etc., meets the requirements of a
reclosing condition detector Rec-2 that a cutoff
command is maintained, the adjacent-line linkage
15 conditions are met, etc., a "reclosing command" is sent
to the circuit breaker CB.

$$||V_L| - |V_k|| < k_1 \quad \dots (6)$$

where V_L represents a line voltage at a phase with an
accident, V_k represents an induced voltage beforehand
20 calculated for the phase with the accident, and k_1
represents a reclosing allowance constant beforehand
calculated based on the currents flowing through the
power transmission lines.

For example, if the value of V_L falls within a
25 range of $0.9 V_k$ to $1.1 V_k$ (i.e., 0.9 to 1.1 times the
value of V_k) based on the reclosing allowance constant
 k_1 , it is determined that V_L is substantially equal to

Vk, thereby sending a reclosing command to the circuit breaker CB.

The aforementioned predetermined value is a voltage, which is induced by normal phases at a phase opened because of the accident, after arc ions produced at the place of an accident are extinguished.

(Operation)

FIG. 5 is a flowchart useful in explaining the operation of the high-speed reclosing system for power transmission lines according to the first embodiment.

If it is determined at step 1 that an accident occurs in a power transmission line and this transmission line is cut off by the protection relay (Yes at step 1), and it is determined at step 2 that a reclosing condition (associated with the reclosing condition detector Rec-2 of FIG. 4) is not satisfied (No at step 2), it is finally determined at step 3 that cutoff is to be performed.

However, if it is determined at step 2 that the reclosing condition (associated with the reclosing condition detector Rec-2 of FIG. 4) is satisfied (Yes at step 2), a target phase in which the accident has occurred is selected at step 4. At step 5, voltage data Vk indicating the voltage assumed at the target phase when it is normal and open is read from the memory means of the protection relay RY, and at step 6, the read voltage data Vk is compared with the measured

line voltage V_L .

If it is determined that the measured value V_L falls within the allowable range of $0.9 V_k$ to $1.1 V_k$ set in view of errors in the measured value, calculated value, the values of the current transformers CT, the voltage transformers VT_L , etc., reclosing is allowed (step 7), and the cut off breaker is reclosed (step 8).

If it is determined that the measured value V_L does not fall within the allowable range of $0.9 V_k$ to $1.1 V_k$ (No at step 6), it is determined at step 9 whether an on-delay timer measures a reclosing resignation time period T_F . If the time period T_F has elapsed ($t > T_F$), cutoff is finally performed (step 10).

FIG. 6 is a view illustrating the concept of the reclosing allowable range, i.e., illustrating the relationship between the induced voltage V_L (measured value) employed in the numerical expression (6), the predetermined value V_k , and the predetermined reclosing allowance constant k_1 .

As is understood from FIG. 6, if the induced voltage V_L measured by the voltage transformer VT_L -A is close to the predetermined value V_k , i.e., falls within the upper and lower limits of V_k determined from the upper and lower limits (0.9 and 1.1) of the reclosing allowance constant k_1 , the numerical expression (6) is satisfied, which means that reclosing is possible.

(Second Example of Reclosing Function Rec)

FIG. 7 shows a second example of the induced-voltage detector Rec-1 of the reclosing function Rec.

In the first example of the induced-voltage detector Rec-1, if $0.9 V_k < V_L < 1.1 V_k$, a reclosing command is issued. In contrast, in the second example of the induced-voltage detector Rec-1, if the ratio of the absolute value of the difference between the absolute value of the measured line voltage V_L and the absolute value of the calculated line voltage V_k , to the absolute value of the calculated value V_k is lower than a predetermined value k_2 , as is shown in the following expression (7), reclosing is executed.

$$\frac{||V_L| - |V_k||}{|V_k|} < k_2 \quad \dots (7)$$

where V_L represents a line voltage at a phase with an accident, V_k represents an induced voltage beforehand calculated for the phase with the accident, and k_2 represents a reclosing allowable ratio beforehand calculated based on the currents flowing through the power transmission lines.

(Advantage)

As described above, in the first embodiment of the present invention, a voltage induced by a normal phase is beforehand detected, and stored as a predetermined value V_k in the protection relay with the reclosing function, and an induced voltage V_L measured upon occurrence of an accident is compared with the stored

value V_k . As a result, it can be easily determined whether reclosing should be executed. This system can also be employed in a reclosing-dedicated apparatus.

[Second Embodiment]

5 A second embodiment of the present invention will be described.

(Structure)

The second embodiment differs from the first embodiment as follows: In the first embodiment, an induced voltage is beforehand calculated. In contrast, 10 in the second embodiment, the induced voltage V_L measured at a phase with an accident is compared with the induced voltage V_k calculated, using the current and voltage read from the current transformer CT and voltage transformer VT_L corresponding to a normal phase 15 after cutoff is executed upon the occurrence of the accident, and assuming that arc ions at the accident phase has been extinguished. If both values are close to each other, a reclosing command is sent to the 20 circuit breaker corresponding to the accident phase.

Since the structures of the protection relay RY and the reclosing function Rec therein are similar to those of the first embodiment shown in FIGS. 1, 2, 4 and 7, no detailed description is given thereof. 25 Similarly, since the above-mentioned predetermined value (approximate value) is described in the first embodiment, it is not described again.

(Operation)

FIG. 8 is a flowchart useful in explaining the operation of the high-speed reclosing system for power transmission lines according to the second embodiment.

5 The flowchart of FIG. 8 differs from that of FIG. 5 in that in the former, step 5 in FIG. 5 is replaced with step 5A. Namely, at step 5A subsequent to the accident phase selection of step 4, the voltage (V_k) assumed at an accident phase if this phase is
10 normal and open is calculated based on the terminal current and voltage of the other normal phases. The other calculation operations in the second embodiment are similar to those described above, and are therefore not described.

15 (Advantage)

As described above, in the second embodiment of the present invention, whether reclosing should be executed can be determined simply by confirming whether the line voltage V_L measured at the accident phase
20 after cutoff is executed is close to the induced voltage (V_k) calculated by the protection relay with the reclosing function based on the voltages induced by the normal phases.

[Third Embodiment]

25 A third embodiment of the present invention will be described.

FIG. 9 illustrates a power system that

incorporates protection relays RY having a reclosing function according to the third embodiment, and FIG. 10 illustrates an example of each protection relay RY of the third embodiment.

5 (Structure)

As shown in FIGS. 9 and 10, each of the protection relays RY with the respective reclosing functions according to the third embodiment is obtained by adding, to each protection relay RY with the reclosing function shown in FIGS. 1 and 2, transmission means S for transmitting, to a destination terminal (terminal B), a signal indicating the line voltage V_L detected by a metering voltage transformer VT_L provided at a terminal (terminal A) opposing the destination terminal, and receiving means R for receiving a line voltage V_L signal sent from the destination terminal, and also adding, to the reclosing function Rec, means for determining whether reclosing should be executed, using those line voltage signals V_L . CL denotes a channel connecting the terminals to each other.

(Operation)

The protection relays mutually transmit and receive, via the channel CL, data indicating the line voltage V_L detected at the respective terminals (A and B).

The line voltage of an accident phase sent from the terminal A and the destination terminal B is

compared with a predetermined value (used for determining whether reclosing is allowable) stored in the protection relay RY with the reclosing function. If the former voltage is close to the predetermined value, a reclosing command is output to the corresponding circuit breakers of both terminals.

FIG. 11 is a flowchart useful in explaining the operation of the high-speed reclosing system for power transmission lines according to the second embodiment.

The flowchart of FIG. 11 differs from that of FIG. 5 in that in the former, before the terminals A and B each determine at step 1 whether cutoff is made due to an accident, step A of mutually transmitting line voltages to the terminals A and B, and step B of mutually receiving the transmitted line voltages by the terminals A and B are subsequently executed, and steps 5₁, 6 and 6₁ are executed in place of steps 5 and 6. At steps 5₁, 6 and 6₁, the received line voltage data V_{LA} and V_{LB} is compared with voltages V_{kA} and V_{kB} , respectively, which are obtained if a current accident phase is normal and open, and are beforehand stored in the protection relays. The other processes are similar to those of FIG. 5.

V_{LA} indicates line voltage data transmitted from the terminal A, V_{LB} indicates line voltage data received by the terminal A, V_{kA} indicates the line voltage calculated at the terminal A at step 5₁ and

corresponding to the voltage induced at a phase when an accident has occurred at the phase and therefore the phase is opened, and V_{k_B} indicates the line voltage calculated at the terminal B at step 5₁ and
5 corresponding to the induced voltage.

At step 6, for the terminal A, the numerical expression for allowing reclosing is set to $0.9 V_{k_A} < V_{L_A} < 1.1 V_{k_A}$. Similarly, at step 6₁, for the terminal B, the numerical expression for allowing reclosing is
10 set to $0.9 V_{k_B} < V_{L_B} < 1.1 V_{k_B}$. When both expressions are satisfied, reclosing is permitted to reclose the circuit breaker corresponding to the accident phase.

(Advantage)

In the third embodiment, the line voltages V_L
15 detected at both terminals A and B are mutually transmitted and received, and both terminal data is used, which enables a single determination level to be set at both terminals. Thus, the reliability of the determination as to whether reclosing should be
20 executed is enhanced.

[Fourth Embodiment]

A fourth embodiment of the present invention will be described.

(Structure)

25 Each of protection relays RY having a reclosing function, according to the fourth embodiment, comprises means for transmitting and receiving line voltages to

and from a facing terminal, and functions to send a reclosing command to an accident phase when the line voltage, measured at the opposite ends of a phase with an accident after cutoff is made due to the occurrence of the accident, is close to the line voltage calculated for the accident phase based on the currents and voltages at the other normal phases, assuming that the accident phase is normal. Since the structure of the protection relay RY with the reclosing function according to the fourth embodiment is similar to that of the third embodiment shown in FIGS. 9 and 10, no description is given thereof.

(Operation)

In the fourth embodiment, line voltage V_L data obtained at facing terminals is transmitted to the respective protection relays RY each having the reclosing function. The protection relays RY at both terminals each calculate a voltage induced by the normal phases, and compare the calculated value with the line voltage V_L of the accident phase. If the calculated values obtained at both terminals are each close to the line voltage V_L , a reclosing command is sent to the accident phase.

FIG. 12 is a flowchart useful in explaining the operation of the fourth embodiment.

The fourth embodiment differs from the third embodiment in that at step 5_{1A} in the former, both V_{kA}

of one terminal and V_{k_B} of the other terminal are used for calculating the line voltage that may well occur at the accident phase assuming that this phase is normal and open. The other processes are similar to those of the flowchart of FIG. 11, and hence no description is given thereof.

(Advantage)

In the fourth embodiment, V_L data obtained at both terminals are mutually transmitted to and received from each other, and it is confirmed at both terminals whether the data is close to the line voltage calculated for an accident phase based on the currents and voltages at the other normal phases, assuming that the accident phase is normal. This enables the same determination level to be employed at both terminals, thereby enhancing the reliability of determination as to whether reclosing should be executed.

[Fifth Embodiment]

A fifth embodiment of the present invention will be described.

(Structure)

The fifth embodiment is characterized in that a condition for starting reclosing is used as a condition for transmitting line voltage data in the third or fourth embodiment. Since the structure of a protection relay RY with a reclosing function according to the fifth embodiment is similar to that of the third

embodiment shown in FIGS. 9 and 10, no description is given thereof.

(Operation)

The fifth embodiment differs from the third and fourth embodiments as follows: In the third and fourth
5 embodiments, line voltage data obtained at respective terminals is always transmitted and received. In contrast, in the fifth embodiment, as shown in the flowchart of FIG. 13, step C for starting reclosing is
10 interposed between step 2 for determining whether a condition for reclosing is satisfied, and step A for transmitting line voltage V_{LA} to a facing terminal. Since the processes after step 4 are similar to those of the flowchart shown in, for example, FIG. 12, no
15 illustration and no description are given thereof.

When line voltage data is transmitted using the condition for starting reclosing as in the fifth embodiment, the data can be transmitted using an area for current data that is not used during reclosing.

(Advantage)

20 Since voltage data is not always transmitted, the number of calculations performed in the protection relay RY with the reclosing function can be reduced, and a transmission line in which the amount of
25 transmission is limited can be utilized.

[Sixth Embodiment]

A sixth embodiment of the present invention will

be described.

(Structure)

The sixth embodiment is obtained by modifying the first to fifth embodiments such that if the line
5 voltage assumed at a phase with an accident after cutoff is made upon occurrence of the accident is not close to the aforementioned predetermined value, a reclosing command is sent to the accident phase when a predetermined time period elapses after the accident.

10 Since the structures of a protection relay RY and a reclosing function Rec in the relay RY, according to the sixth embodiment, are similar to those of the first embodiment shown in FIGS. 1, 2, 4 and 7, and to the third embodiment shown in FIGS. 9 and 10, no
15 description is given thereof.

(Operation)

FIG. 14 is a flowchart useful in explaining the operation of the sixth embodiment.

At step 6 of the sixth embodiment, if the line
20 voltage V_L assumed at a phase with an accident after cutoff is made upon occurrence of the accident is not close to the aforementioned predetermined value V_k (No at step 6), the process proceeds to step 9 where it is determined whether a predetermined time period (T_m : no-voltage time period) elapses after the accident. If it
25 is determined that the predetermined time period has elapsed, the process skips over step 7 to step 8, where

a circuit breaker CB corresponding to the accident phase is reclosed. A no-voltage period timer is started upon the reclosing of the circuit breaker CB. During the no-voltage time period, it is detected
5 whether the line voltage is close to the predetermined value, and if it is not close to the value, a reclosing command is sent to the circuit breaker CB corresponding to the accident phase after the predetermined time period elapses.

10 (Advantage)

To enable reclosing even if the line voltage is not close to the predetermined value, a reclosing system using a conventional no-voltage period count timer is also employed, thereby providing a backup
15 effect.

[Seventh Embodiment]

A seventh embodiment of the present invention will be described.

(Structure)

20 The seventh embodiment is obtained by modifying the first to fifth embodiments such that if the phase difference (θ) between the voltage assumed at an accident phase after cutoff is made, and the voltage at each normal phase is close to a predetermined value, a
25 reclosing command is sent to the accident phase.

FIG. 15 shows the structure of a protection relay RY with a reclosing function according to the seventh

embodiment. The structure shown in FIG. 15 is obtained by replacing the induced voltage detector Rec-1 employed in the structure of the first embodiment shown in FIG. 4 or 7, with an allowable range detector Rec-3 for detecting whether a phase difference between the measured voltage value V_L and the calculated value V_k of the line voltage. Since the other structures of the seventh embodiment are similar to those of the first embodiment, no detailed description is given thereof.

FIG. 16 is a view useful in explaining the induced voltage and the allowable range in phase difference, V_k and V_L indicating the levels and phases of the measured and calculated voltages.

(Operation)

The seventh embodiment differs from the first through fifth embodiments in that in the former, the voltage and the phase thereof induced at an accident phase by normal phases are of a three-phase AC voltage. In this embodiment, a database concerning the relationship between predetermined voltages and phases is prestored in the protection relay with the reclosing function. The line voltage assumed at a phase with an accident after cutoff is made upon occurrence of the accident is compared with a predetermined value beforehand associated with the voltage. If it is determined as a result of comparison that they are close to each other, a reclosing command is sent to the

accident phase.

FIG. 17 is a flowchart illustrating the operation of the seventh embodiment.

At step 6, the line voltage V_k to be detected at an accident phase if this phase is normal is compared with the measured line voltage V_L , and if it falls within predetermined voltage and phase ranges associated with the phase as given by the following numerical expression (8), reclosing is allowed to reclose the corresponding circuit breaker:

$$0.9 V_k < V_L < 1.1 V_k \quad \dots (8)$$

$$(V_L \wedge V_k \leq \theta)$$

(Advantage)

The voltage and phase induced at the accident phase can easily be detected since a three-phase AC voltage is applied, thereby enhancing the reliability of the reclosing execution determination.

[Eighth Embodiment]

An eighth embodiment of the present invention will be described.

(Structure)

The eighth embodiment is obtained by modifying the three to fifth embodiments and the seventh embodiment such that when a terminal determines that reclosing is allowable, the determination result is sent to the other terminal, and only if both terminals determine that reclosing is allowable, reclosing is executed.

Since the structures of the protection relay RY and the reclosing function Rec in the eighth embodiment are similar to those of the first embodiment shown in FIGS. 1, 2, 4 and 7, and those of the third embodiment shown in FIGS. 9 and 10, no detailed description is given thereof.

(Operation)

The eighth embodiment differs from the three to fifth embodiments and the seventh embodiment in that in the former, when a terminal determines that reclosing is allowable, the determination result is sent to the other terminal, and only if both terminals determine that reclosing is allowable, reclosing is executed.

FIG. 18 is a flowchart useful in explaining the operation of the eighth embodiment.

In the eighth embodiment, step 71 for transmitting a reclosing allowance command from a certain terminal to an opposing terminal, and step 72 for receiving a reclosing allowance command from the opposing terminal are provided after the step 7 explained with reference to the flowcharts of FIGS. 11 and 12. If the answer to the step 72 is No, an on-delay timer T_F for measuring a no-voltage time period is started at step 9, and only when reclosing conditions are satisfied at both terminals, reclosing is allowed to reclose a corresponding circuit breaker.

(Advantage)

In the eighth embodiment, since reclosing allowance signals are mutually transmitted and received by both terminals, both terminals can simultaneously reclose the corresponding circuit breaker. If a
5 reclosing allowable signal cannot be received from the opposing terminal, cutoff is made after a predetermined time period elapses. Since thus, reclosing is allowed only when reclosing conditions are satisfied at both
10 terminals, the reliability of the determination as to whether reclosing should be executed is further enhanced.

As described above in detail, according to the present invention, it is possible to provide a
15 reclosing system for power transmission lines, which can easily detect the extinguishing time of arc ions in an accident phase, and hence can prevent occurrence of an accident during reclosing.

C L A I M S

1. A reclosing system for a power transmission line (TL), which performs high-speed reclosing using protection relays (RY), the protection relays (RY) being provided at different terminals of the power transmission line (TL), each of the protection relays (RY) comprising a protection calculation function (Pro) and a reclosing function (Rec), the protection calculation function (Pro) being configured to receive voltage signals detected by a metering voltage transformer (VT_L) and current signals detected by a metering current transformer (CT) to execute a predetermined protection calculation to thereby cut off a phase with an accident on the power transmission line (TL), the reclosing function (Rec) being configured to output a reclosing command to a circuit breaker (CB) when the phase with the accident becomes to satisfy a reclosing condition,

characterized in that each of the protection relays (RY) comprises means for sending the reclosing command to the circuit breaker when a line voltage at the phase with the accident, detected by the metering voltage transformer (VT_L) after the phase with the accident is cut off, falls within an allowable range, the allowable range being determined based on a line voltage assumed at the phase when the phase is normal.

2. A reclosing system for a power transmission

line (TL), which performs high-speed reclosing using protection relays (RY), the protection relays (RY) being provided at different terminals of the power transmission line (TL), each of the protection relays (RY) comprising a protection calculation function (Pro) and a reclosing function (Rec), the protection calculation function (Pro) being configured to receive voltage signals detected by a metering voltage transformer (VT_L) and current signals detected by a metering current transformer (CT) to execute a predetermined protection calculation to thereby cut off a phase with an accident on the power transmission line (TL), the reclosing function (Rec) being configured to output a reclosing command to a circuit breaker (CB) when the phase with the accident becomes to satisfy a reclosing condition,

characterized in that each of the protection relays (RY) comprises means for sending the reclosing command to the circuit breaker when a line voltage at the phase with the accident, detected by the metering voltage transformer (VT_L) after the phase with the accident is cut off, falls within an allowable range, the allowable range being determined based on a line voltage calculated for the phase assuming that the phase is normal, the calculated line voltage being acquired based on a current and a voltage at a normal phase of the power transmission line.

3. The reclosing system according to claim 1 or 2, characterized in that each of the protection relays (RY) comprises transmission means (S) provided at one terminal for transmitting a line voltage to another terminal, and receiving means (R) provided at the terminal for receiving a line voltage from said another terminal, and

a reclosing command is sent to the circuit breaker when both line voltage data items related to the phase with the accident and held at the terminals of the power transmission line (TL) fall within a predetermined allowable range.

4. The reclosing system according to claim 1 or 2, characterized in that each of the protection relays (RY) comprises transmission means (S) provided at one terminal for transmitting a line voltage to another terminal, and receiving means (R) provided at said one terminal for receiving a line voltage from said another terminal, and

a reclosing command is sent to the circuit breaker when both line voltage data items, which are related to the phase with the accident, acquired after the phase is cut off, and held at the terminals of the power transmission line (TL), indicates a line voltage close to a line voltage calculated for the phase assuming that the phase is normal, the calculated line voltage being acquired based on a current and a voltage at a

normal phase of the power transmission line.

5. The reclosing system according to anyone of claims 3 and 4, characterized in that the line voltage data items are transmitted based on a condition for starting reclosing.

6. The reclosing system according to anyone of claims 1 to 4, characterized in that when the line voltage assumed at the phase with the accident after the phase is cut off does not fall with the predetermined allowable range, the reclosing command is sent to the circuit breaker after a predetermined time period elapses.

7. The reclosing system according to anyone of claims 1 to 5, characterized in that when a line voltage and a phase thereof measured at the phase with the accident after the phase is cut off is close to a predetermined value, the reclosing command is sent to the circuit breaker.

8. The reclosing system according to anyone of claims 3, 4, 5, and 7, characterized in that when it is determined at one terminal that reclosing is allowable, data indicating that reclosing is allowable is sent to another terminal, and only if the data indicates that a condition set at said one terminal for allowing the reclosing coincides with a condition set at said another terminal for allowing the reclosing, reclosing is executed.

9. The reclosing system according to claim 1 or 2, characterized in that the allowable range is $\frac{||V_L| - |V_k||}{|V_k|} < k1$ where V_L represents the line voltage at the phase with the accident and falls within a range of 0.9 V_k to 1.1 V_k , V_k represents an induced voltage beforehand calculated for the phase with the accident, the induced voltage being induced by a normal phase of the power transmission line, and $k1$ represents a reclosing allowance constant beforehand calculated based on currents flowing through the power transmission line.

10. The reclosing system according to claim 1 or 2, characterized in that the allowable range is $\frac{||V_L| - |V_k||}{|V_k|} < k2$ where V_L represents the line voltage at the phase with the accident and falls within a range of 0.9 V_k to 1.1 V_k , V_k represents an induced voltage beforehand calculated for the phase with the accident, the induced voltage being induced by a normal phase of the power transmission line, and $k2$ represents a reclosing allowable ratio beforehand calculated based on currents flowing through the power transmission line.

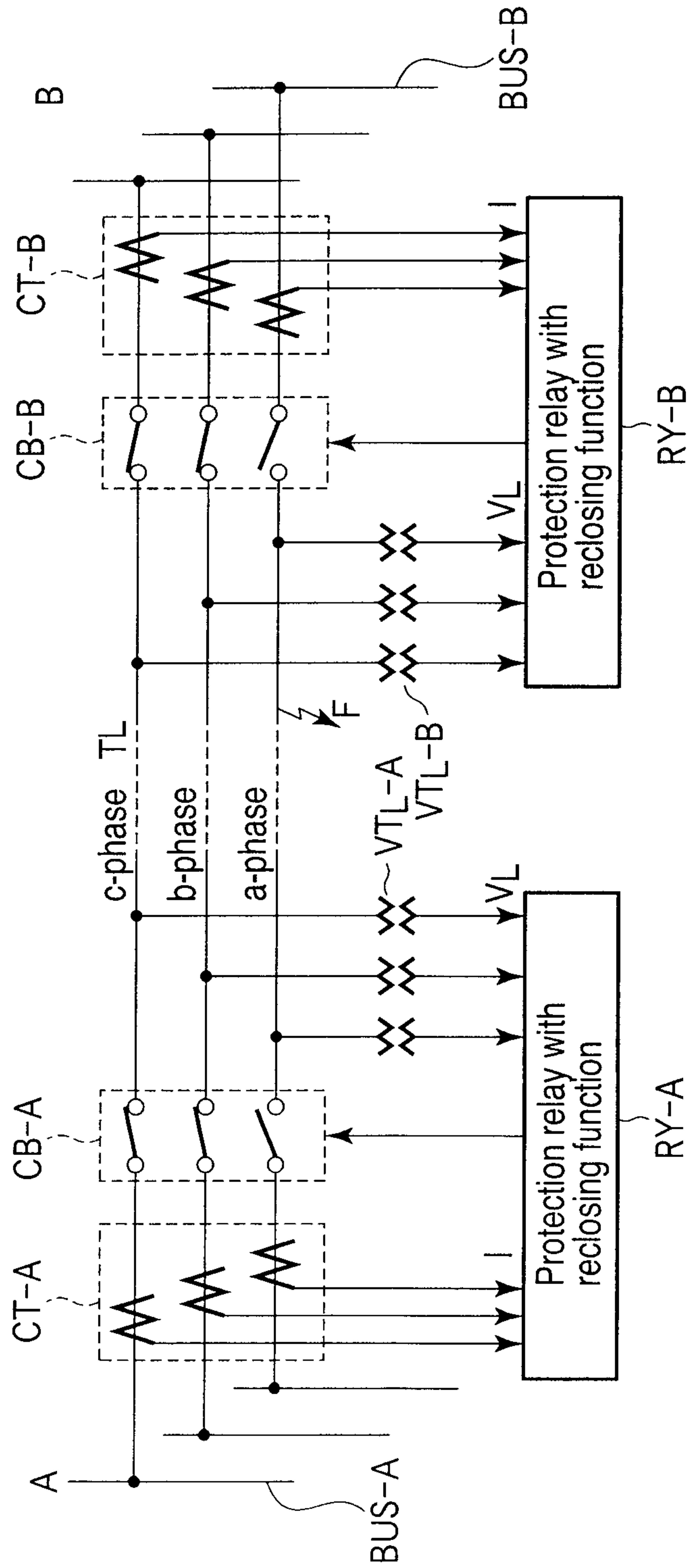

FIG. 1

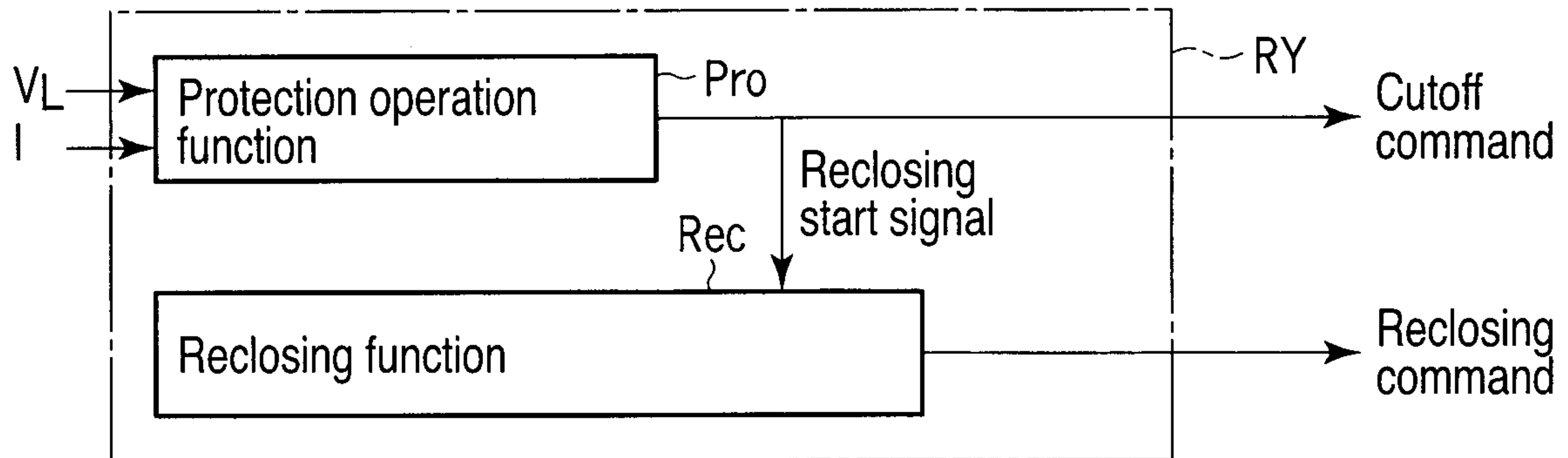

FIG. 2

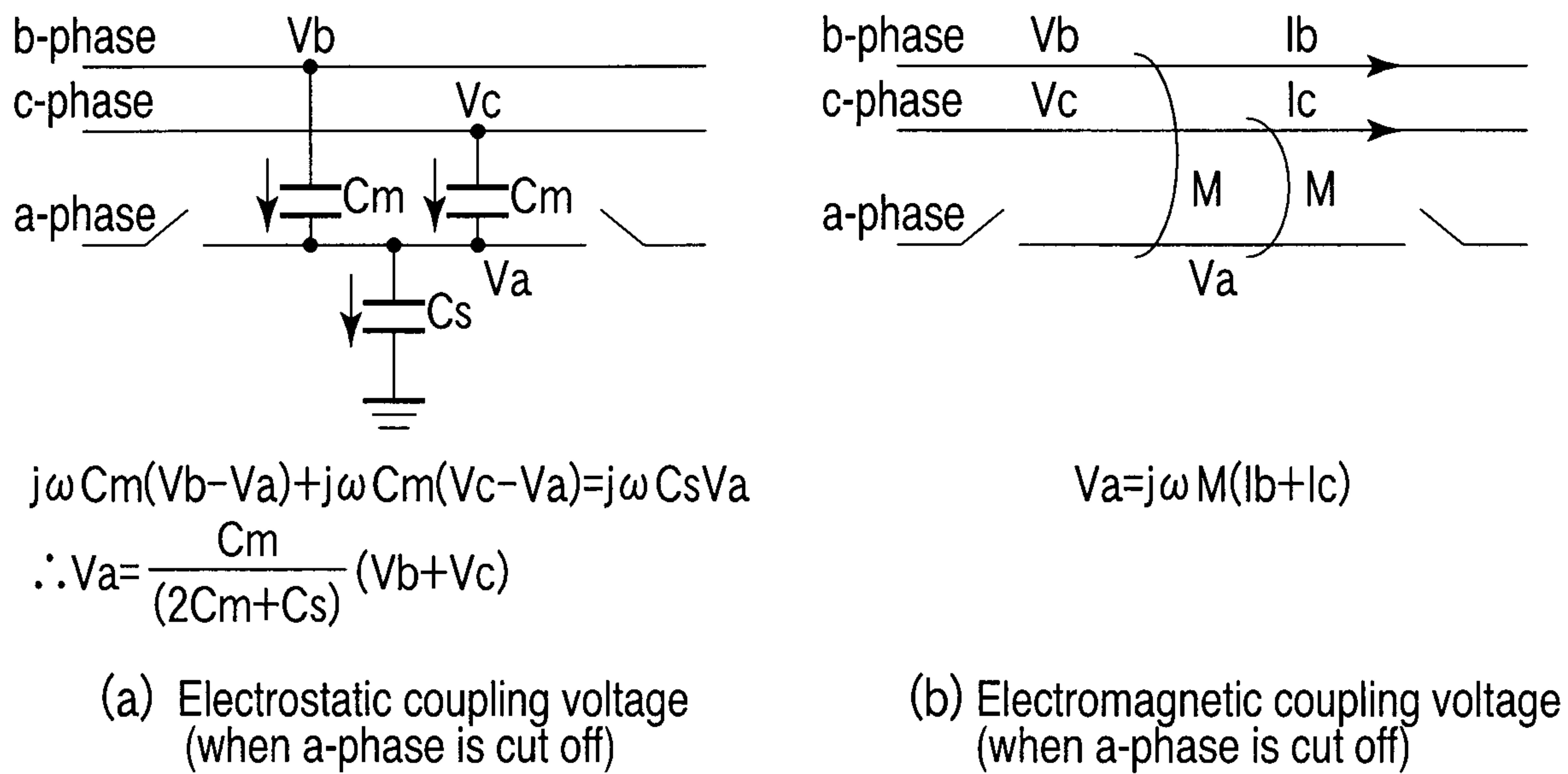

FIG. 3

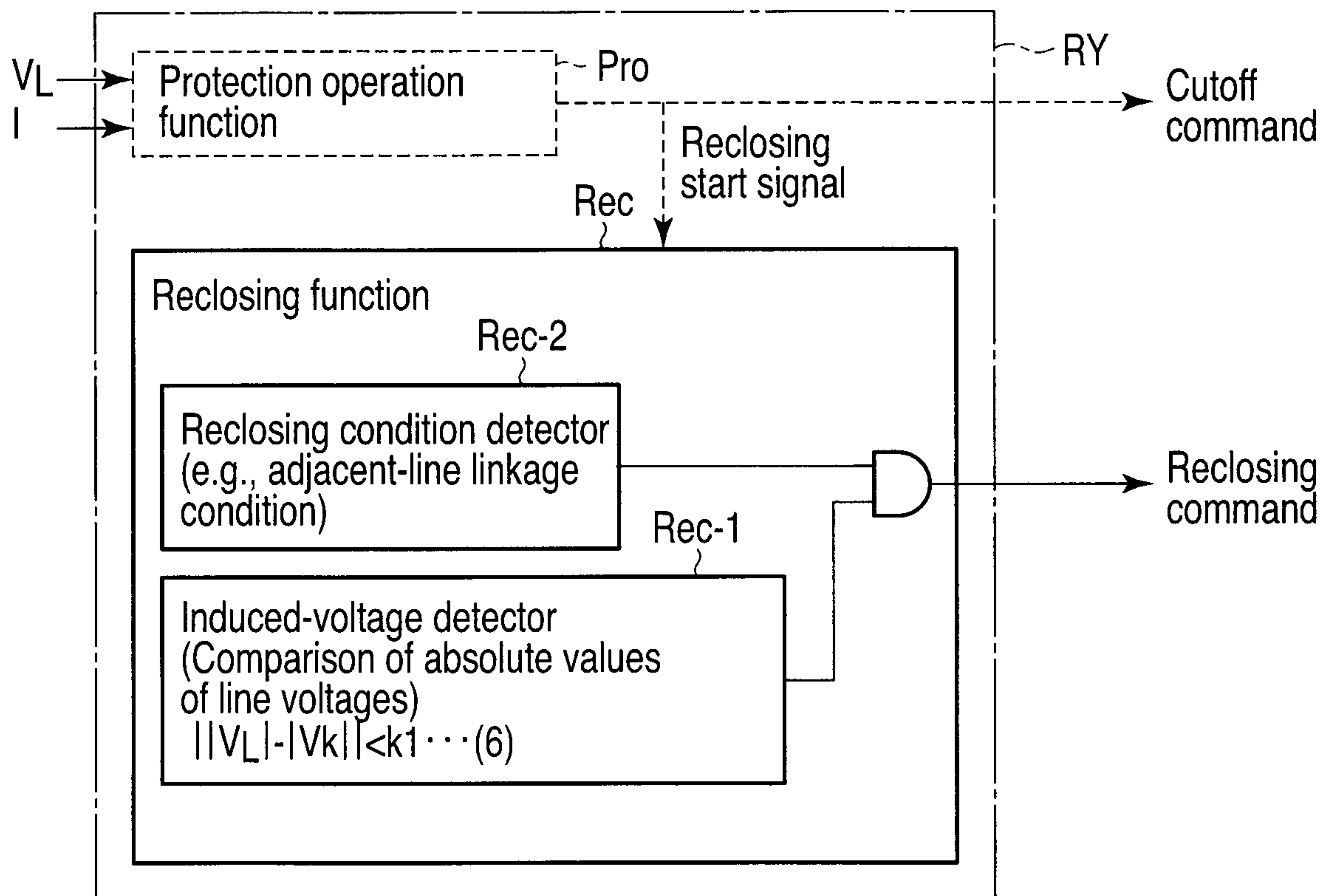

FIG. 4

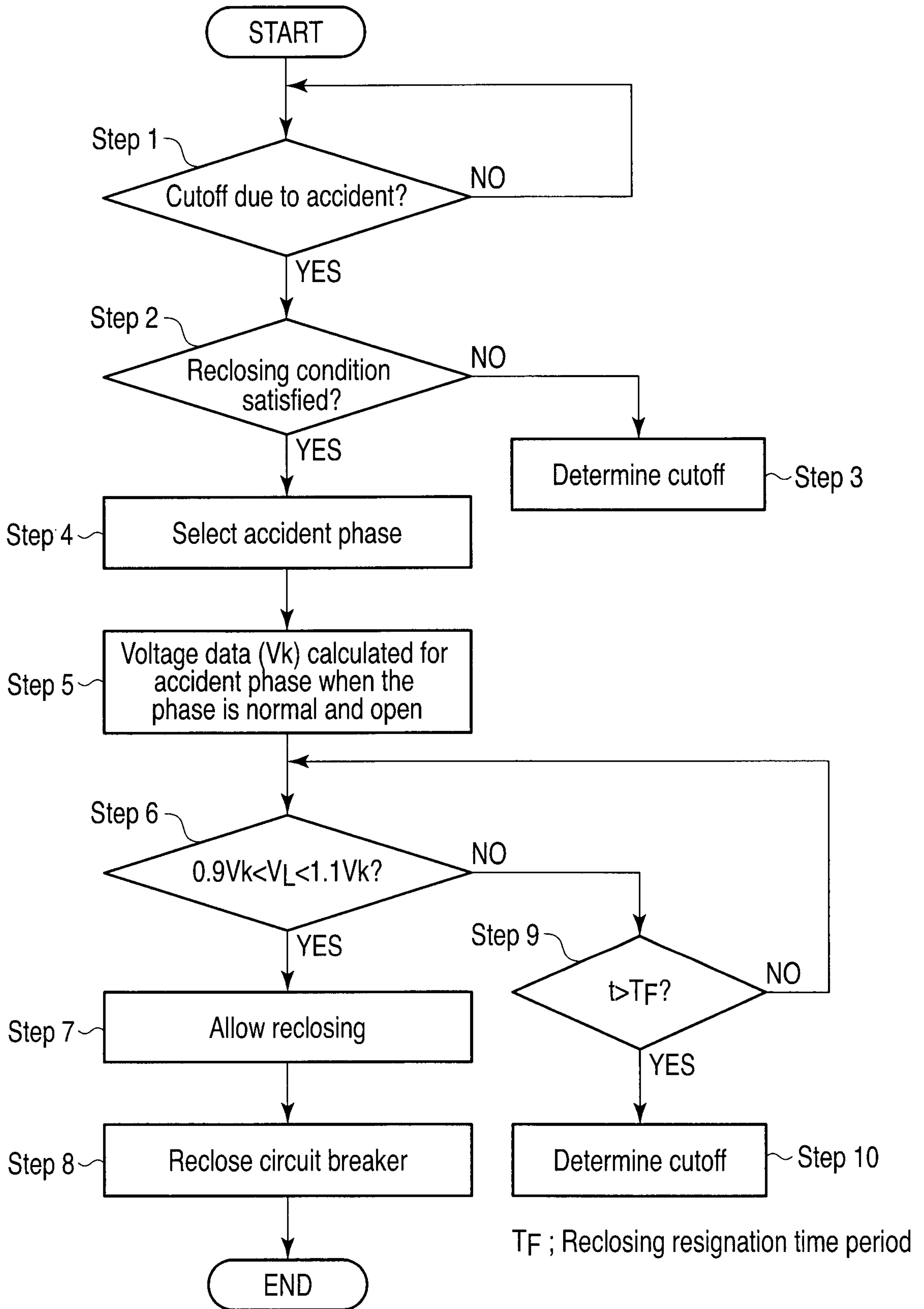

FIG. 5

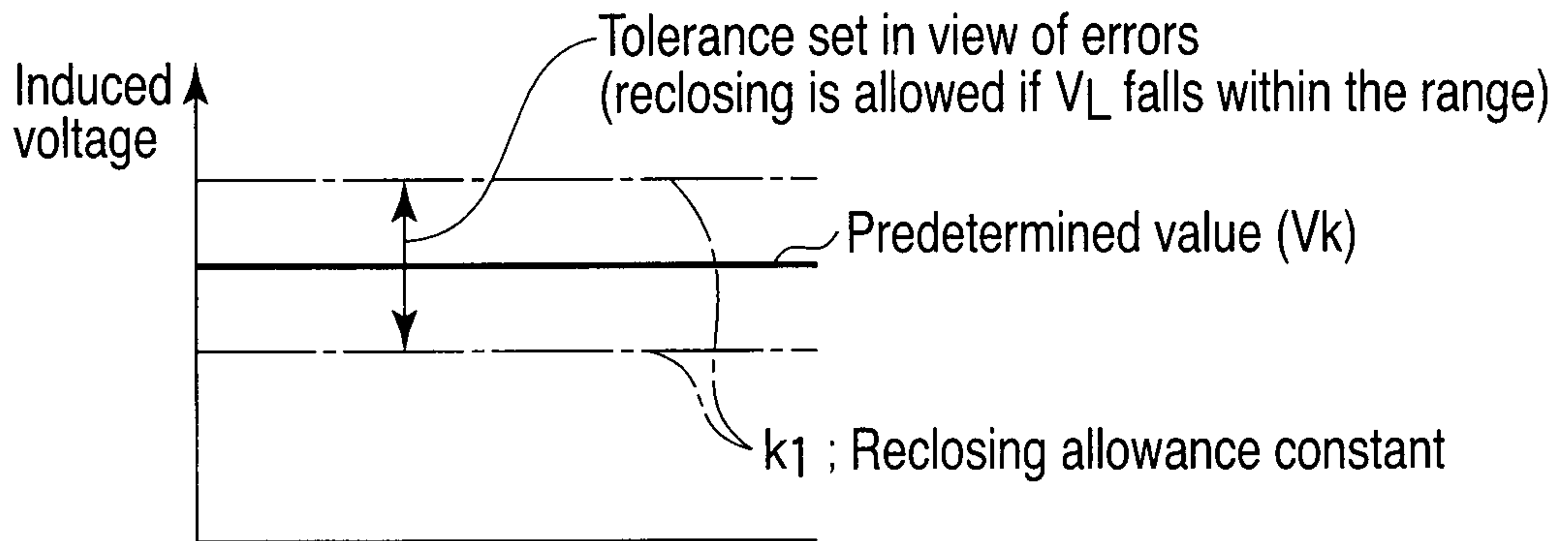

FIG. 6

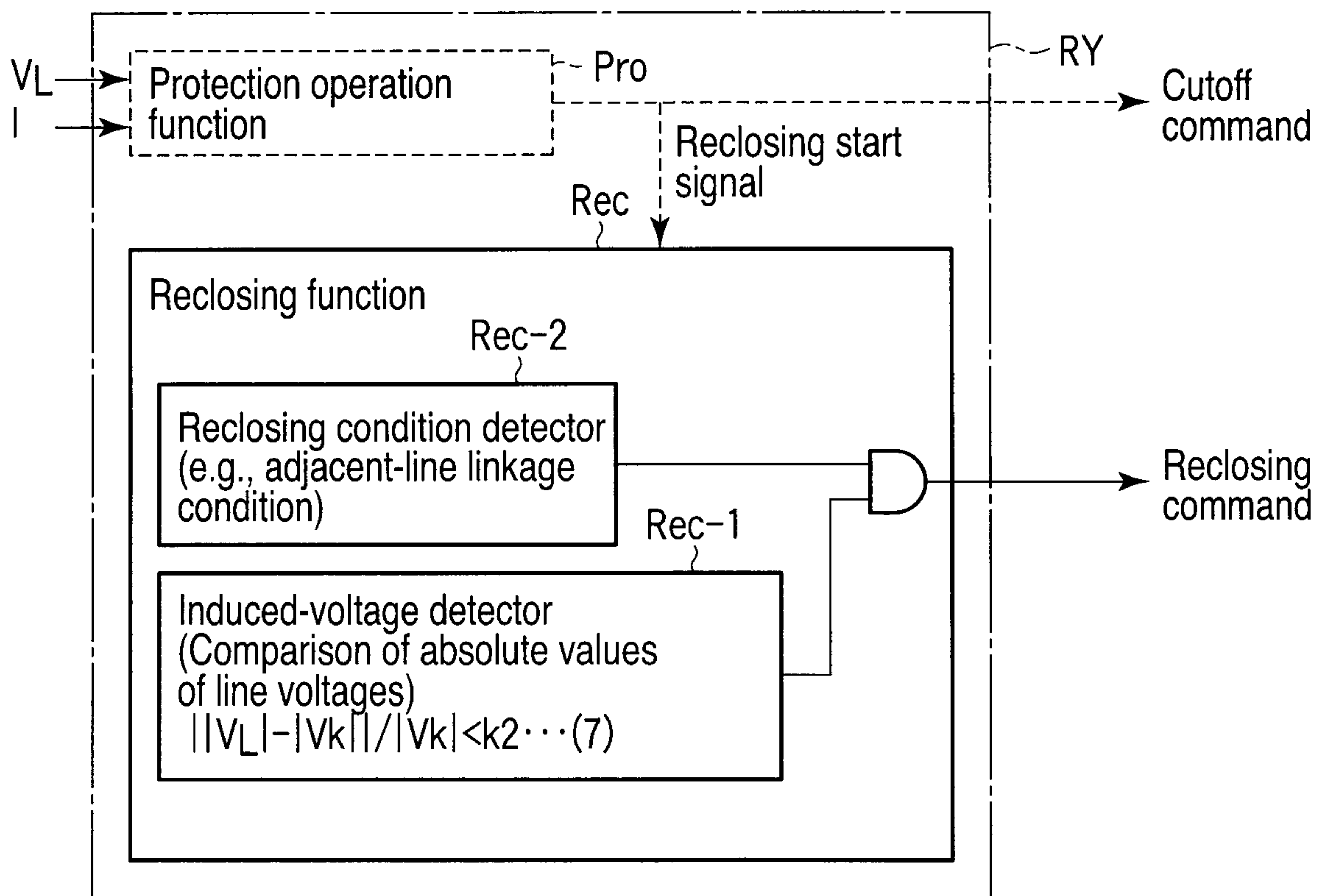

FIG. 7

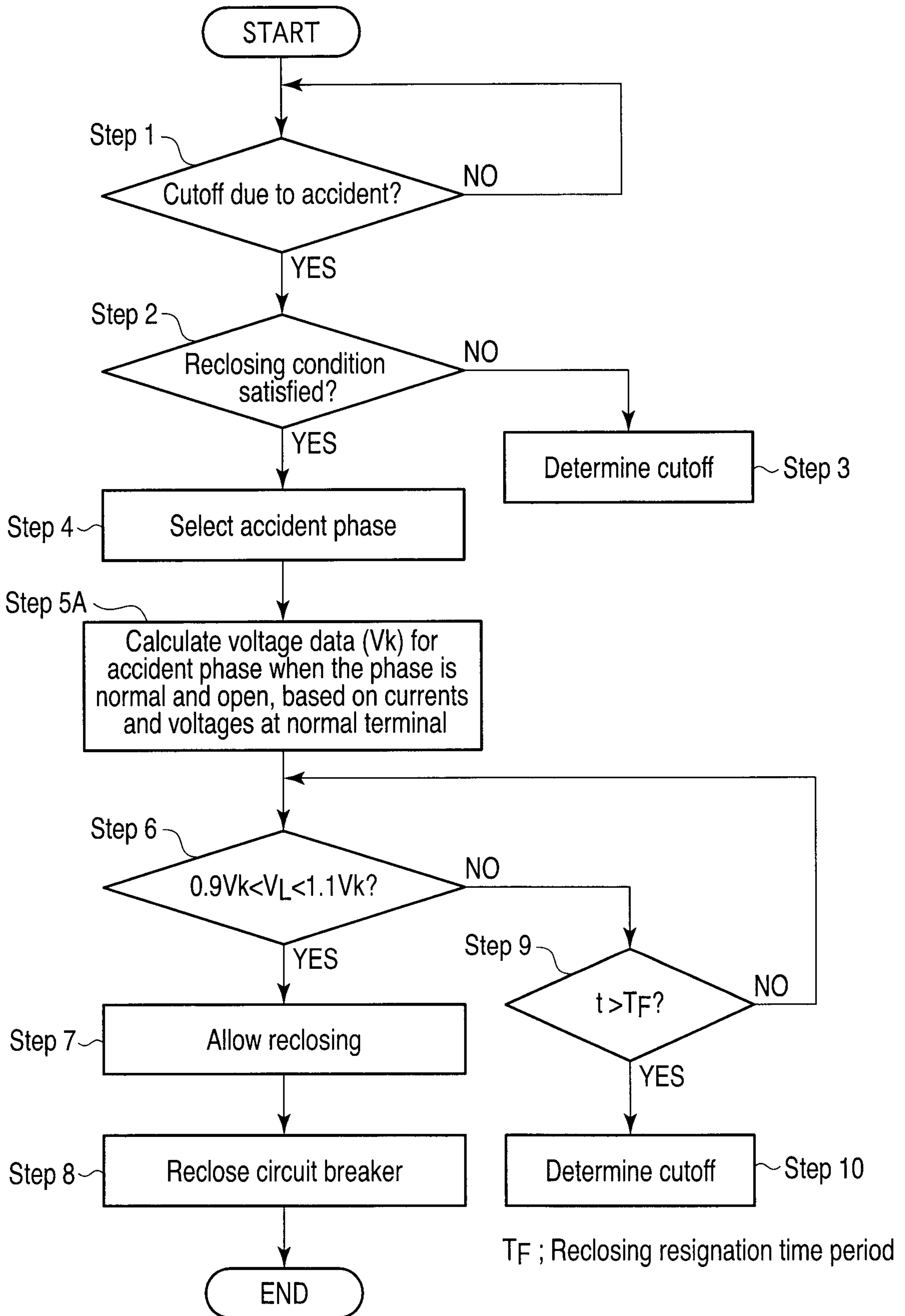

FIG. 8

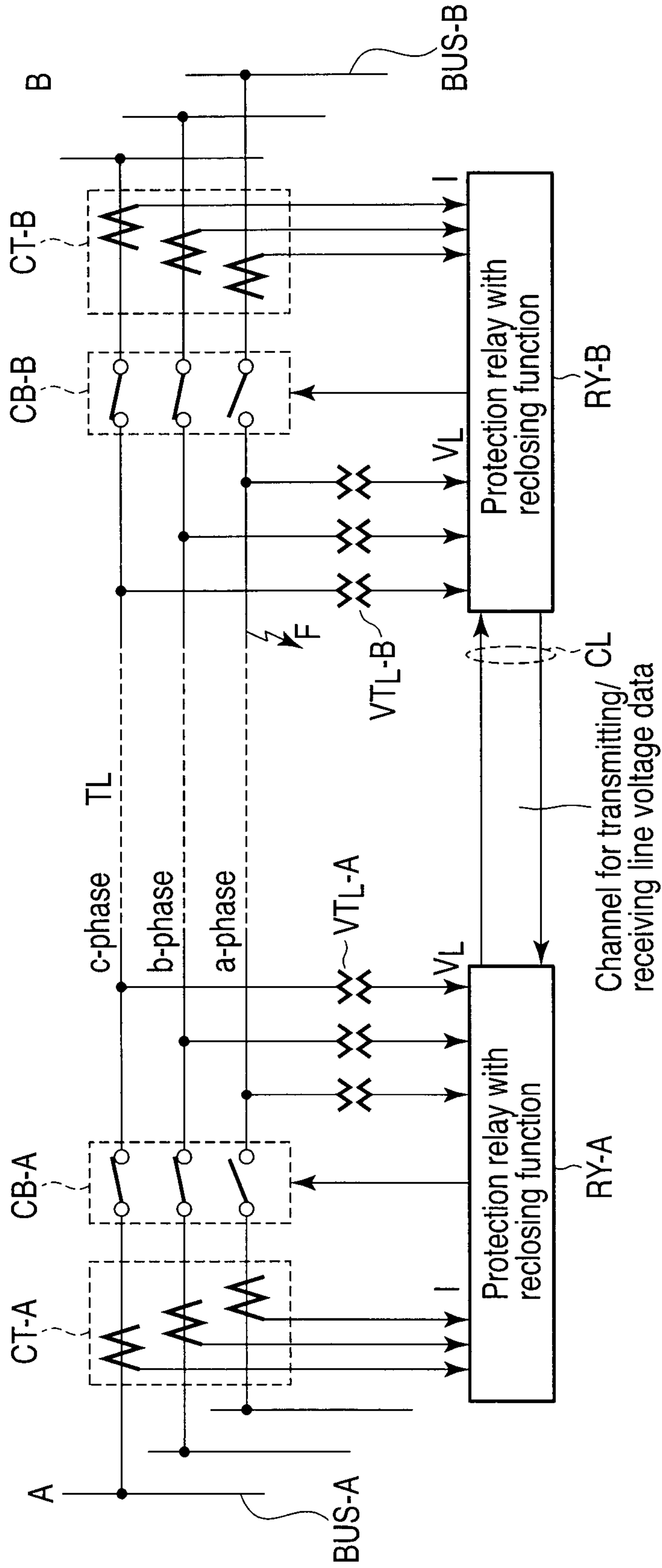

FIG. 9

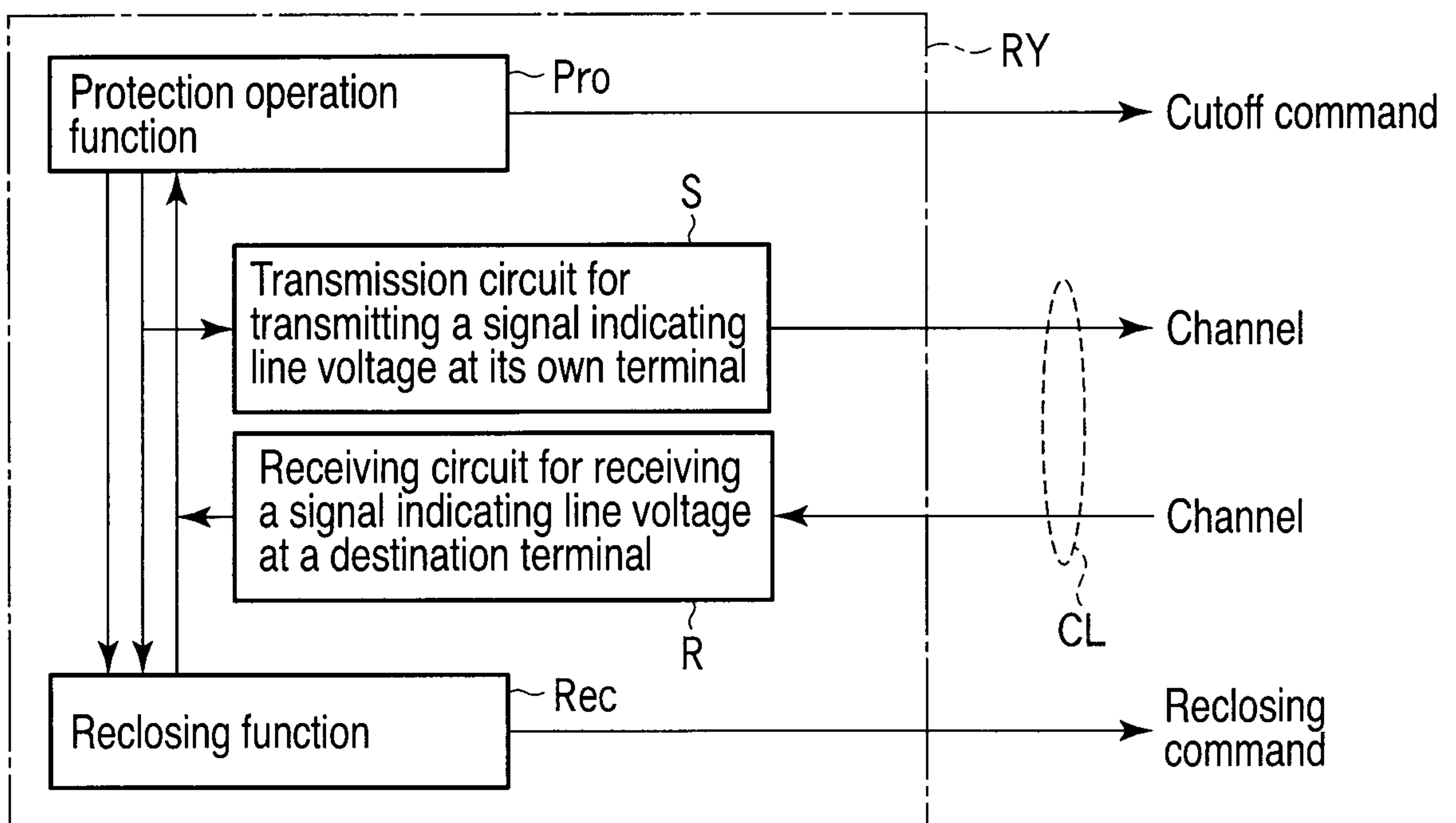

FIG. 10

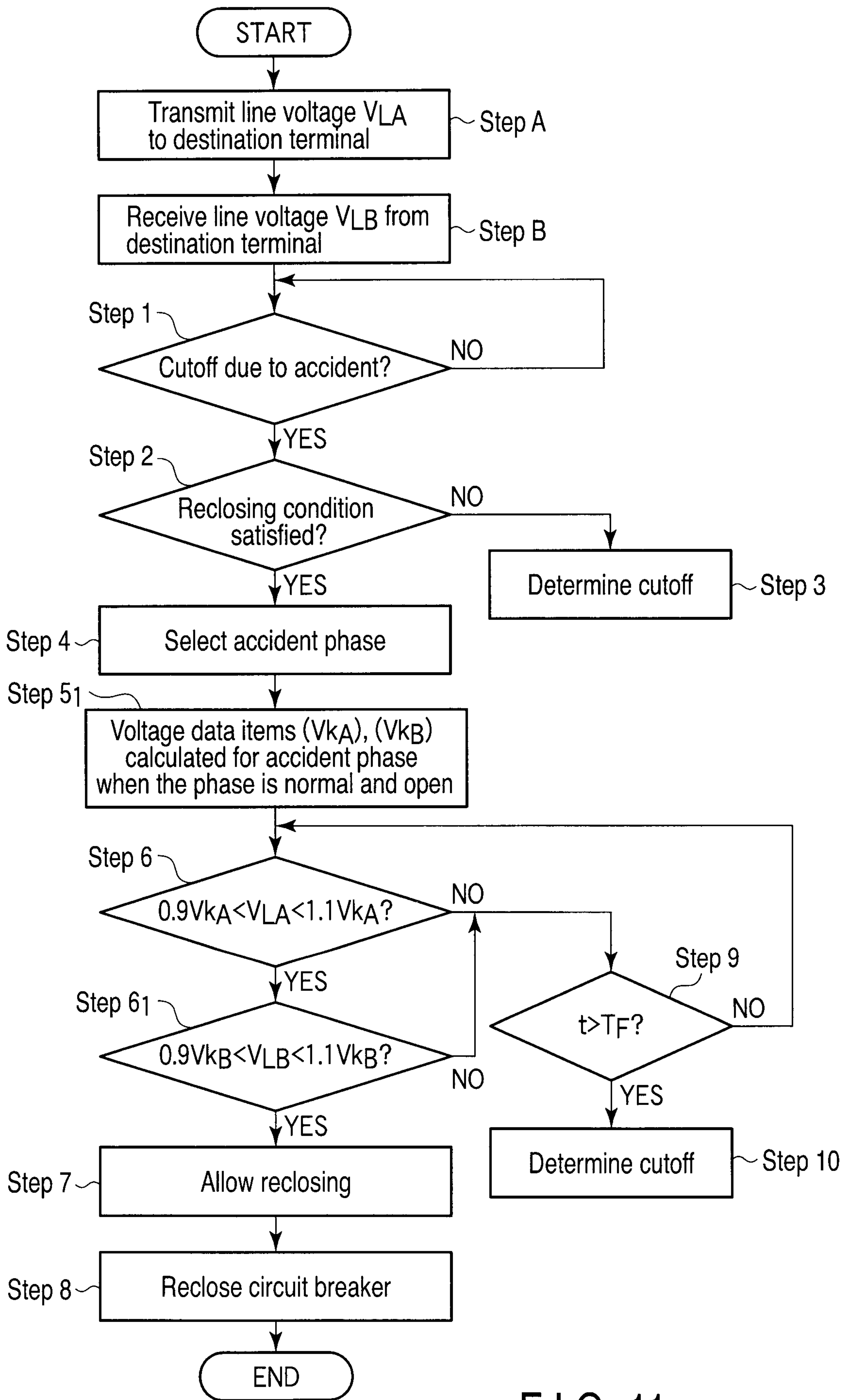

FIG. 11

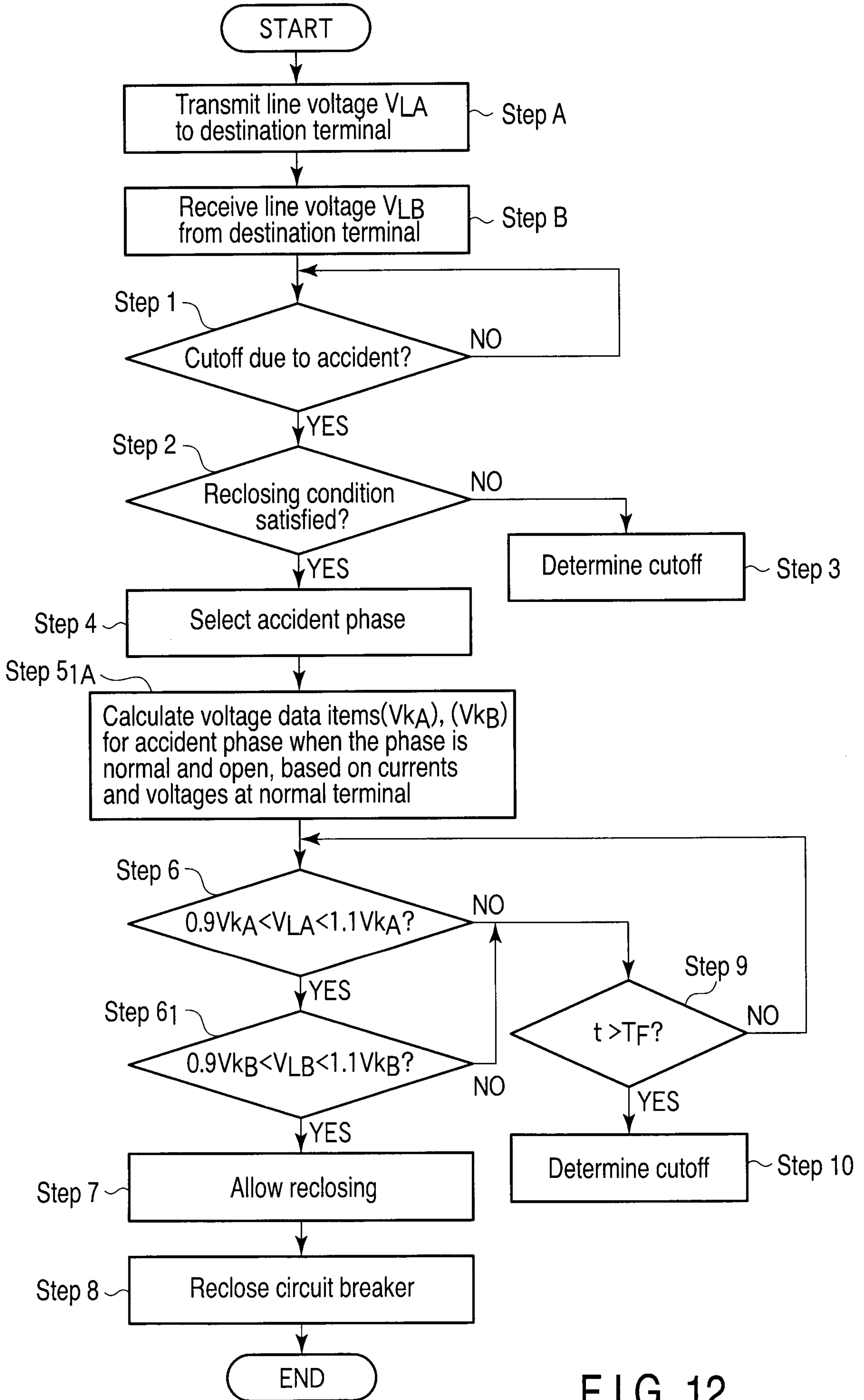

FIG. 12

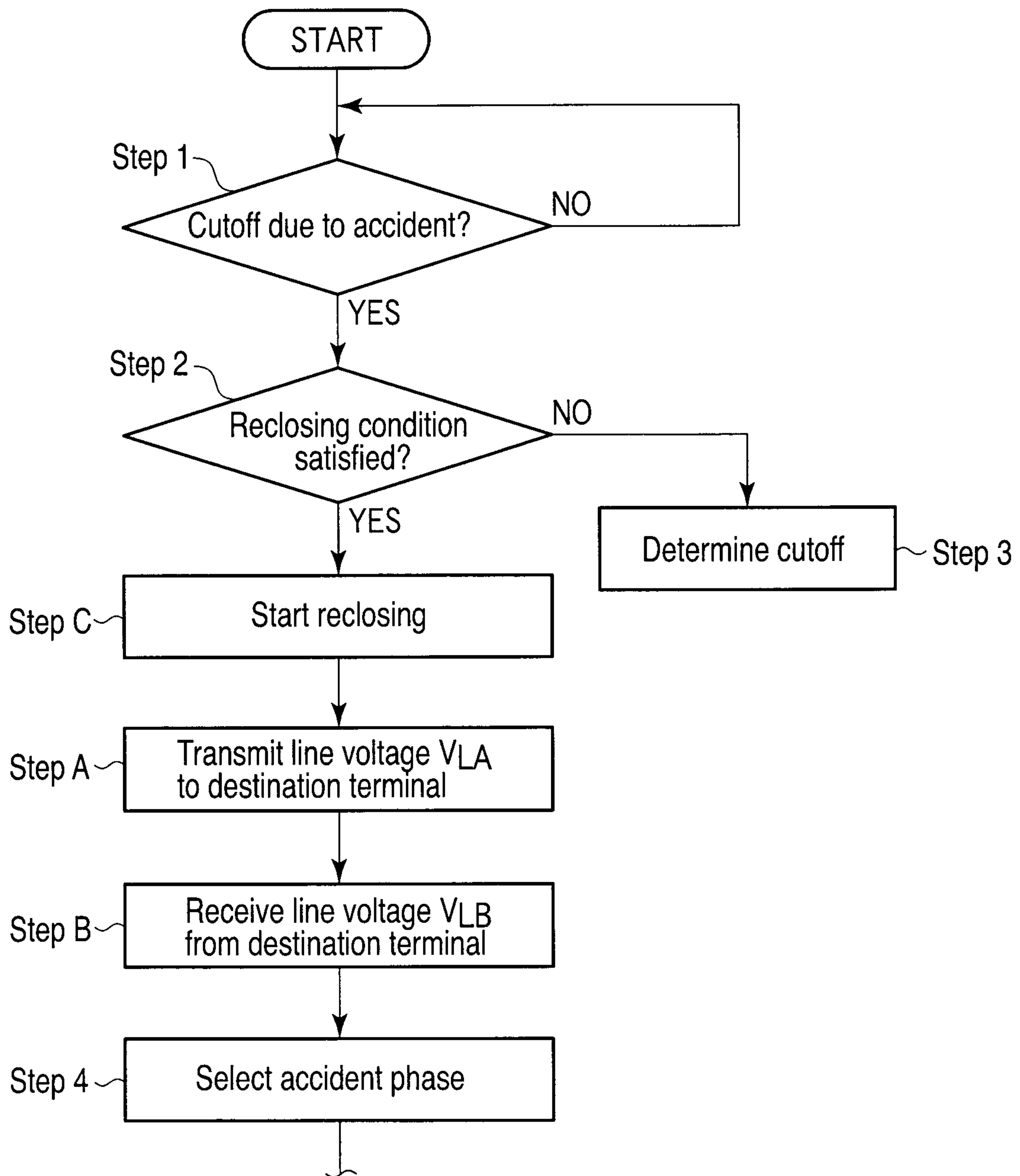

FIG. 13

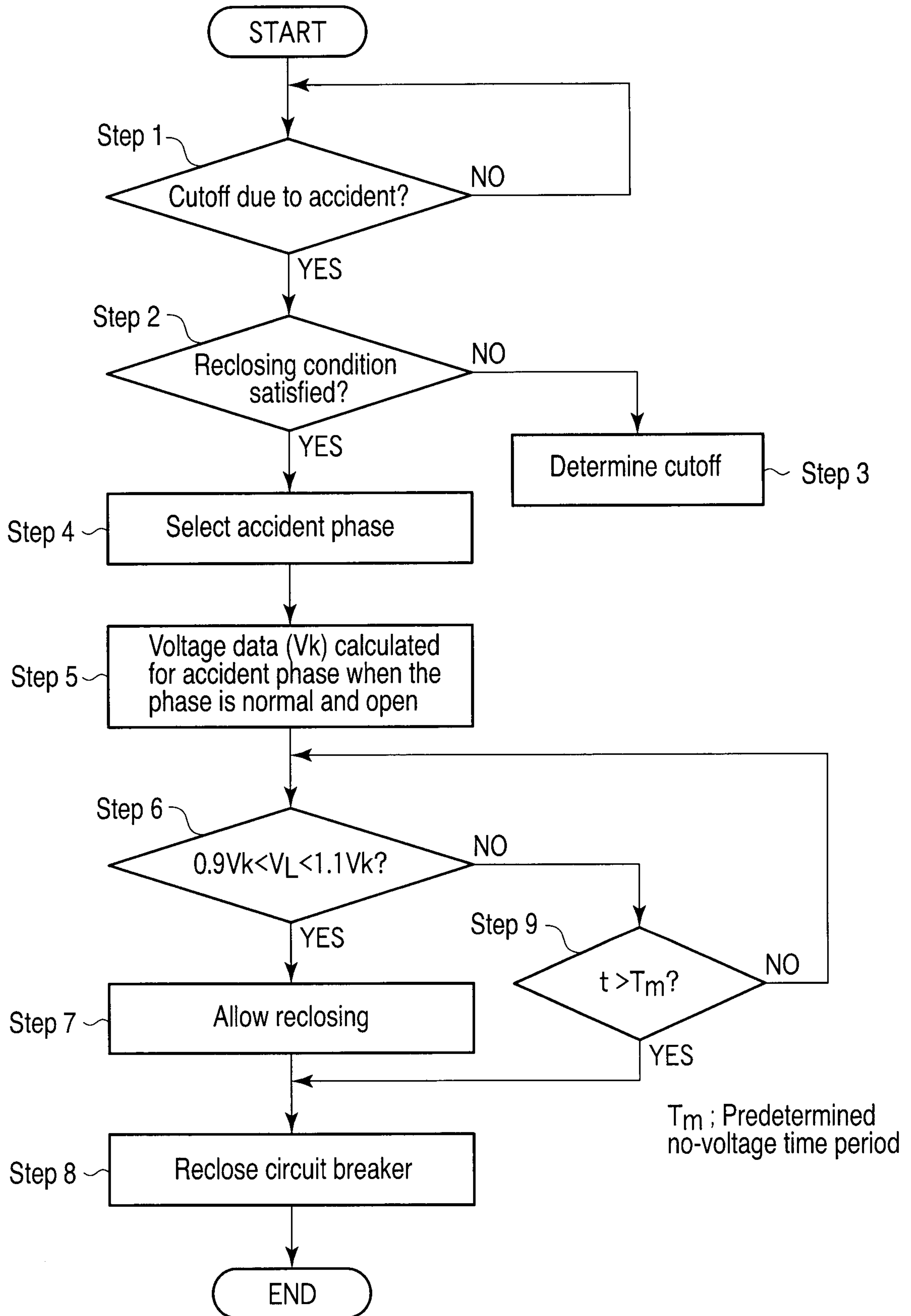

FIG. 14

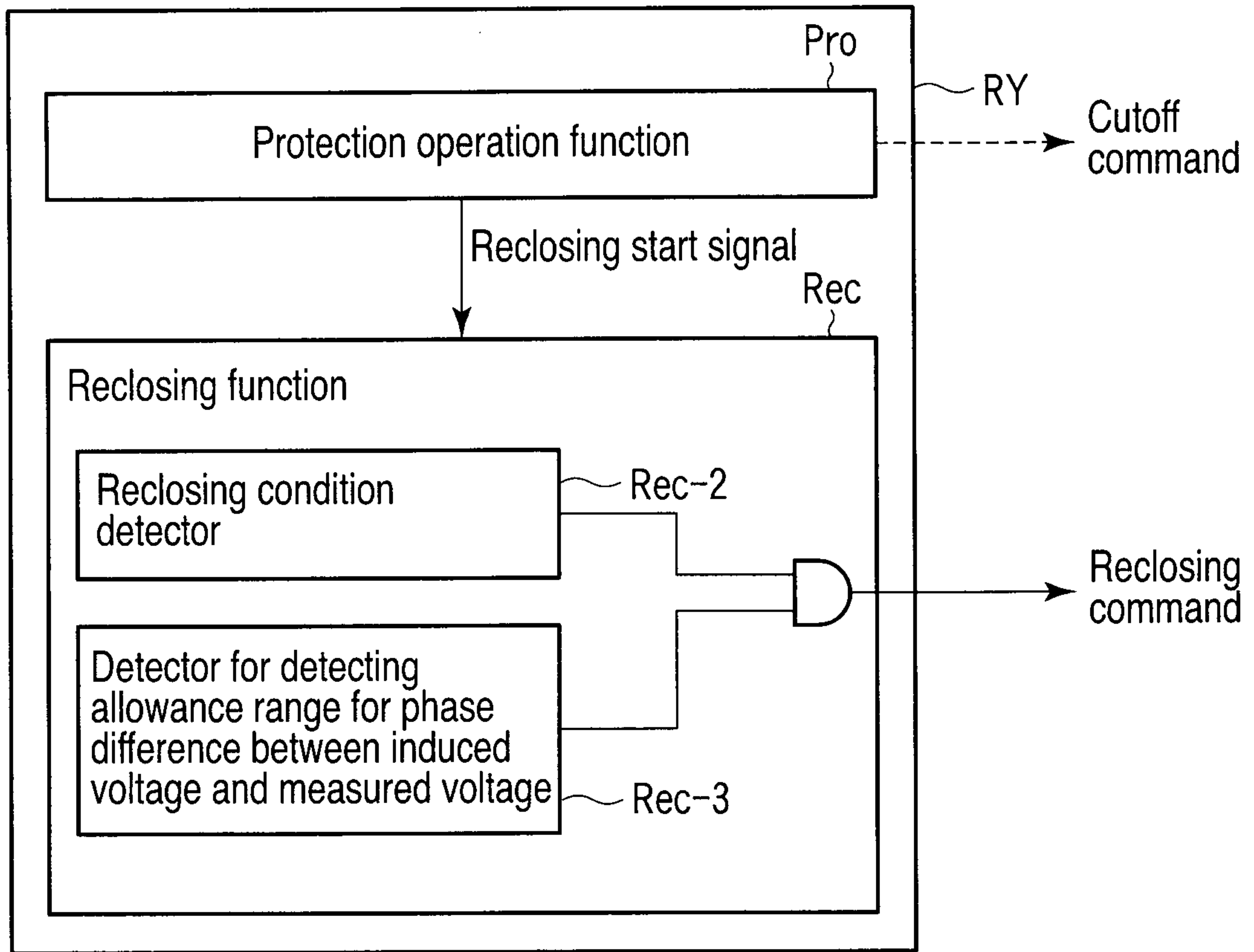

FIG. 15

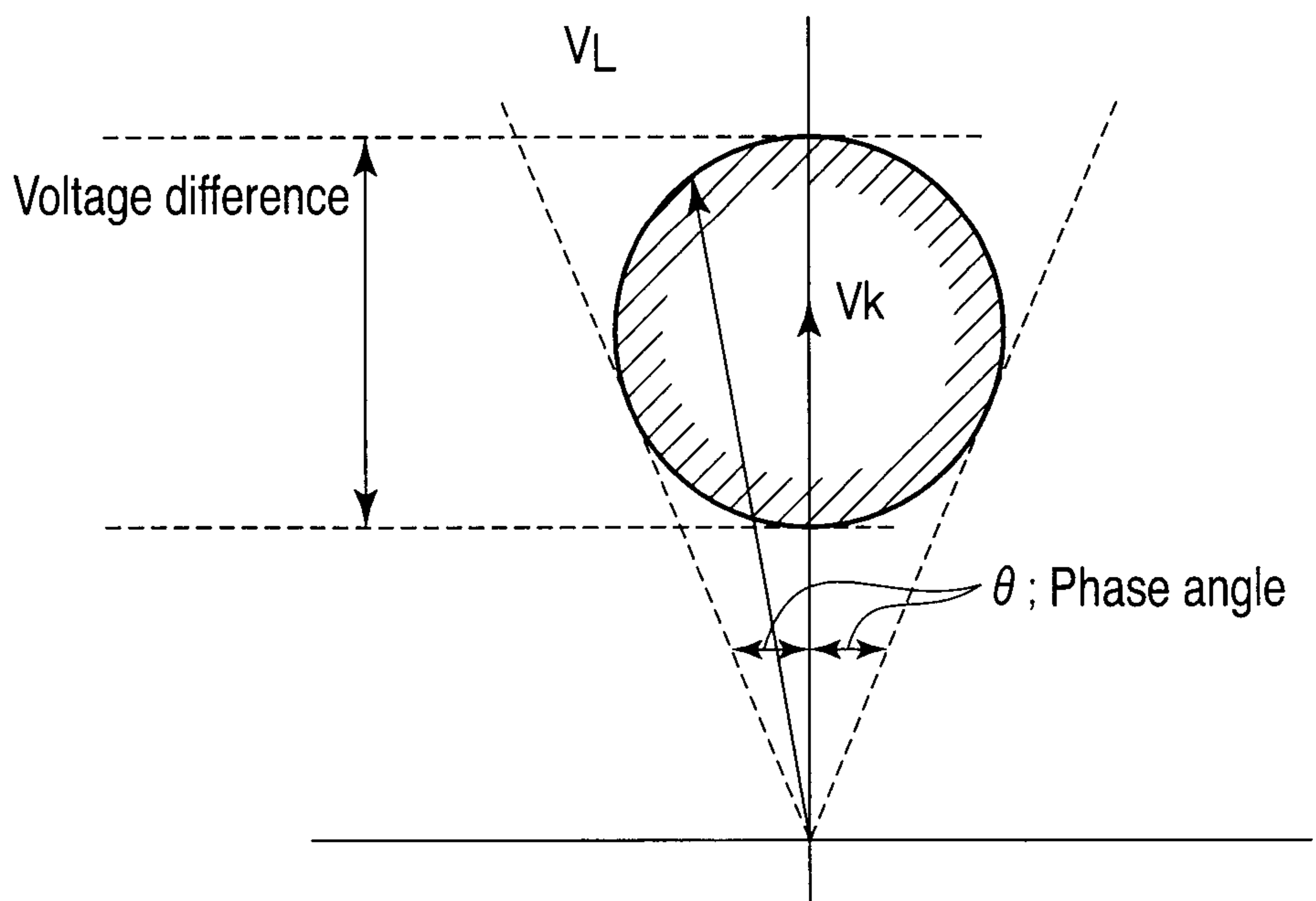

FIG. 16

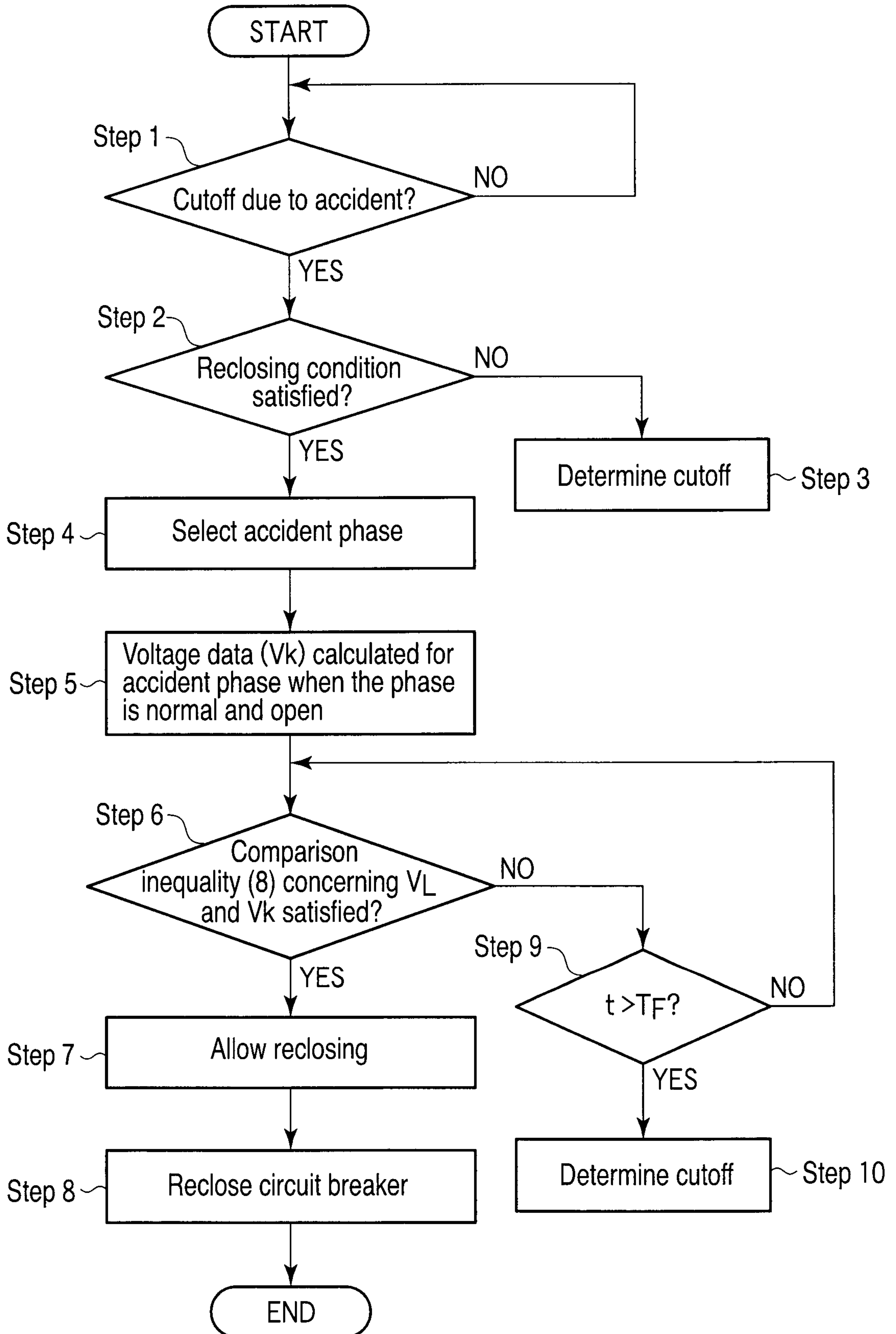

FIG. 17

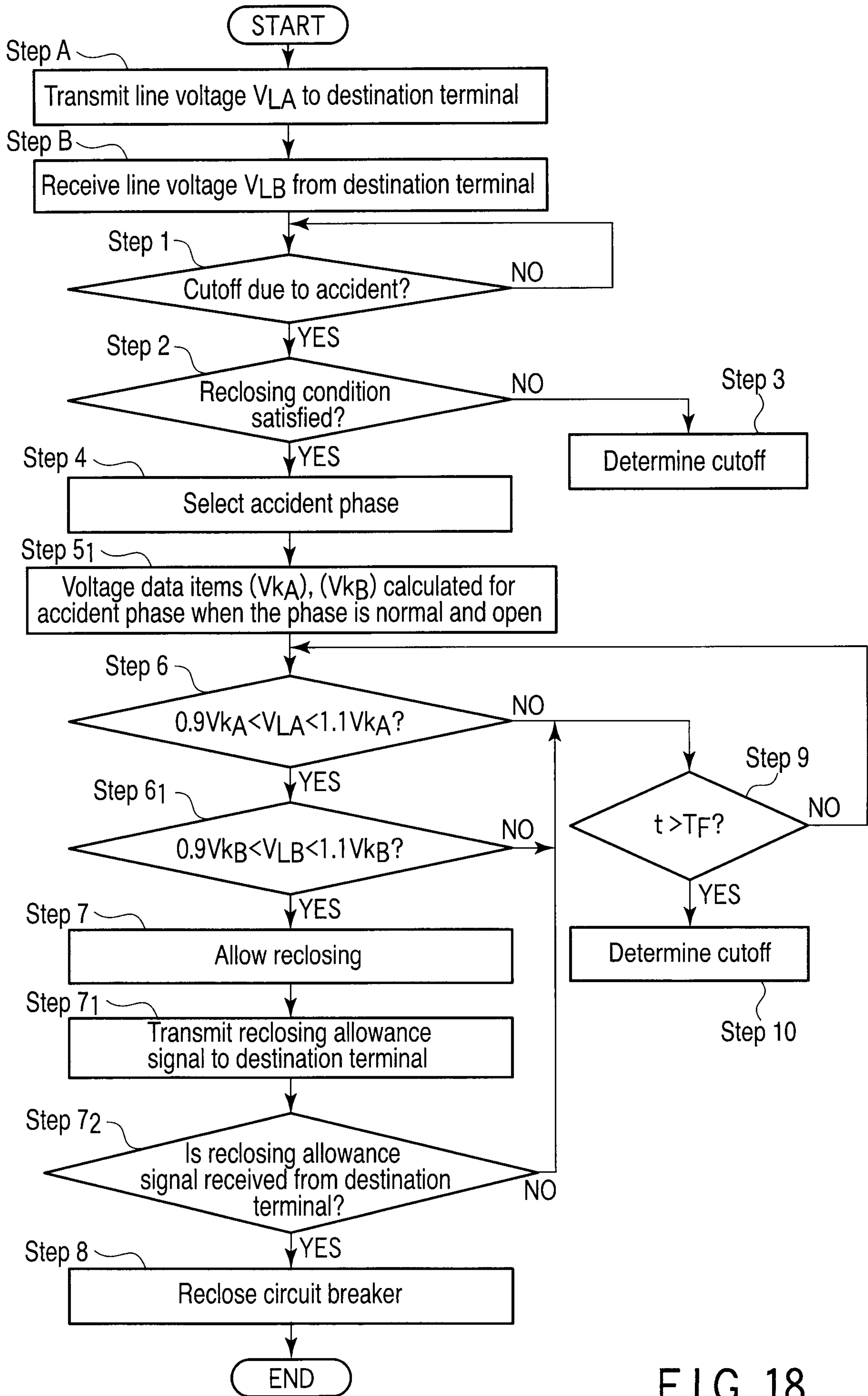

FIG. 18

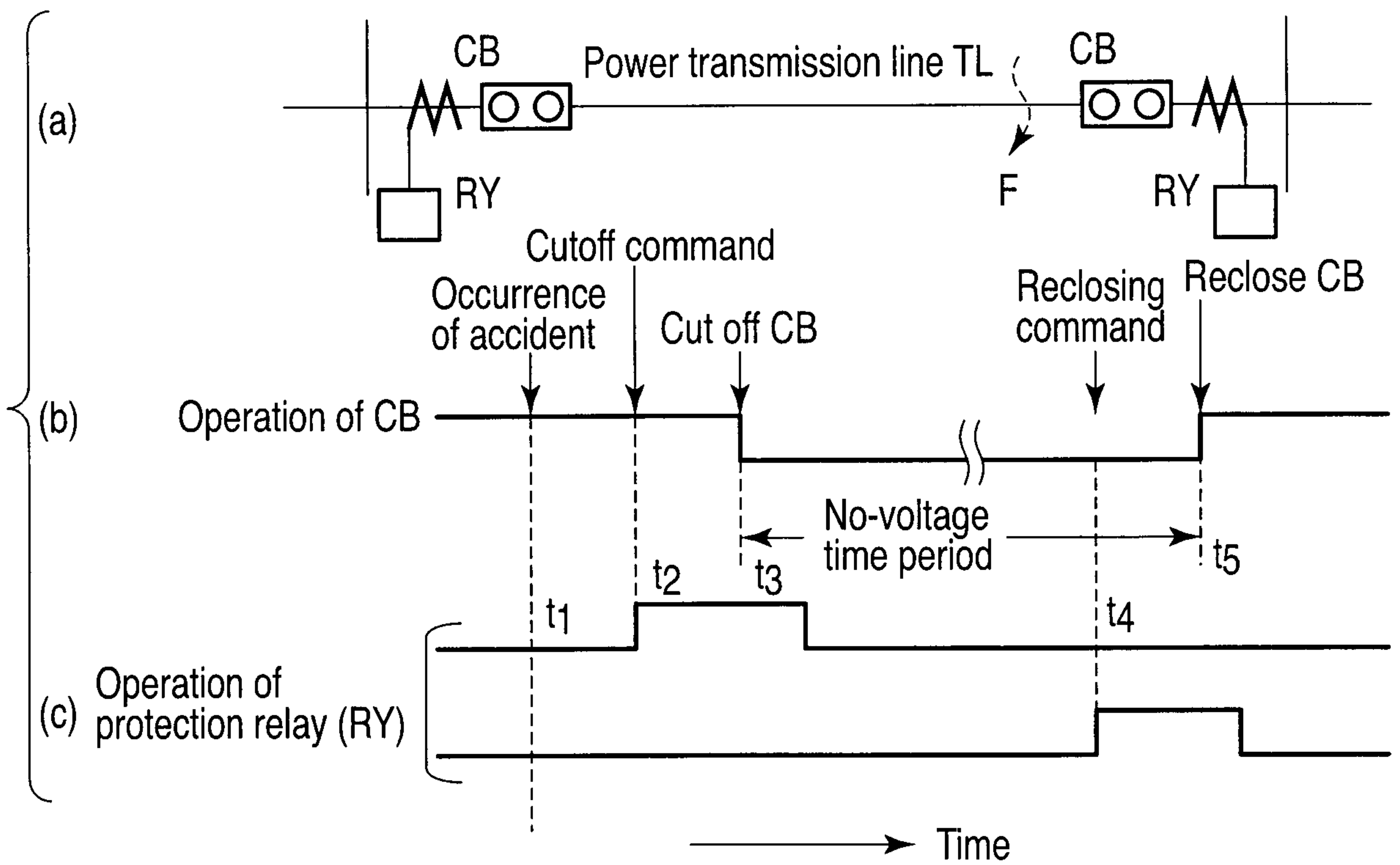

FIG. 19

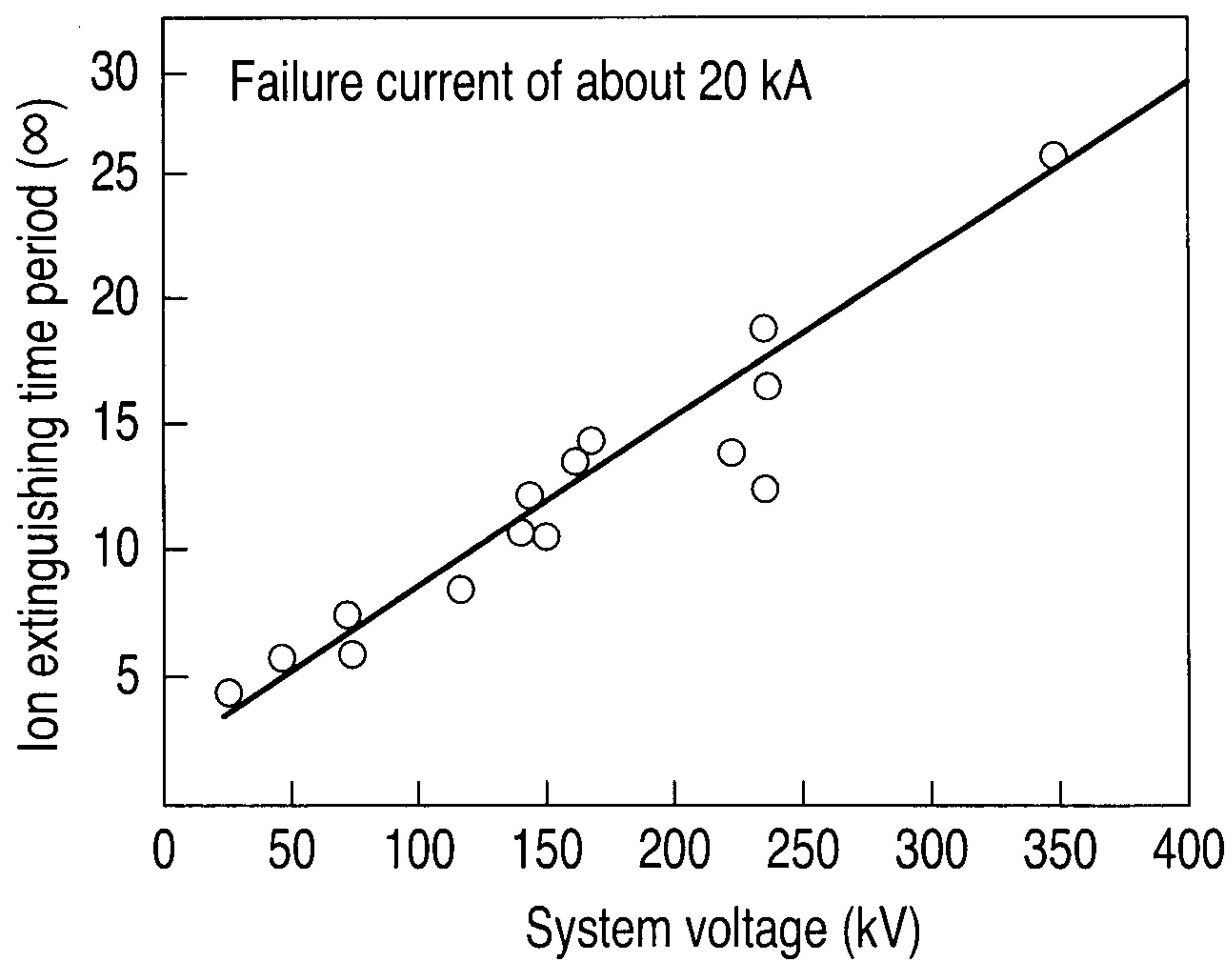
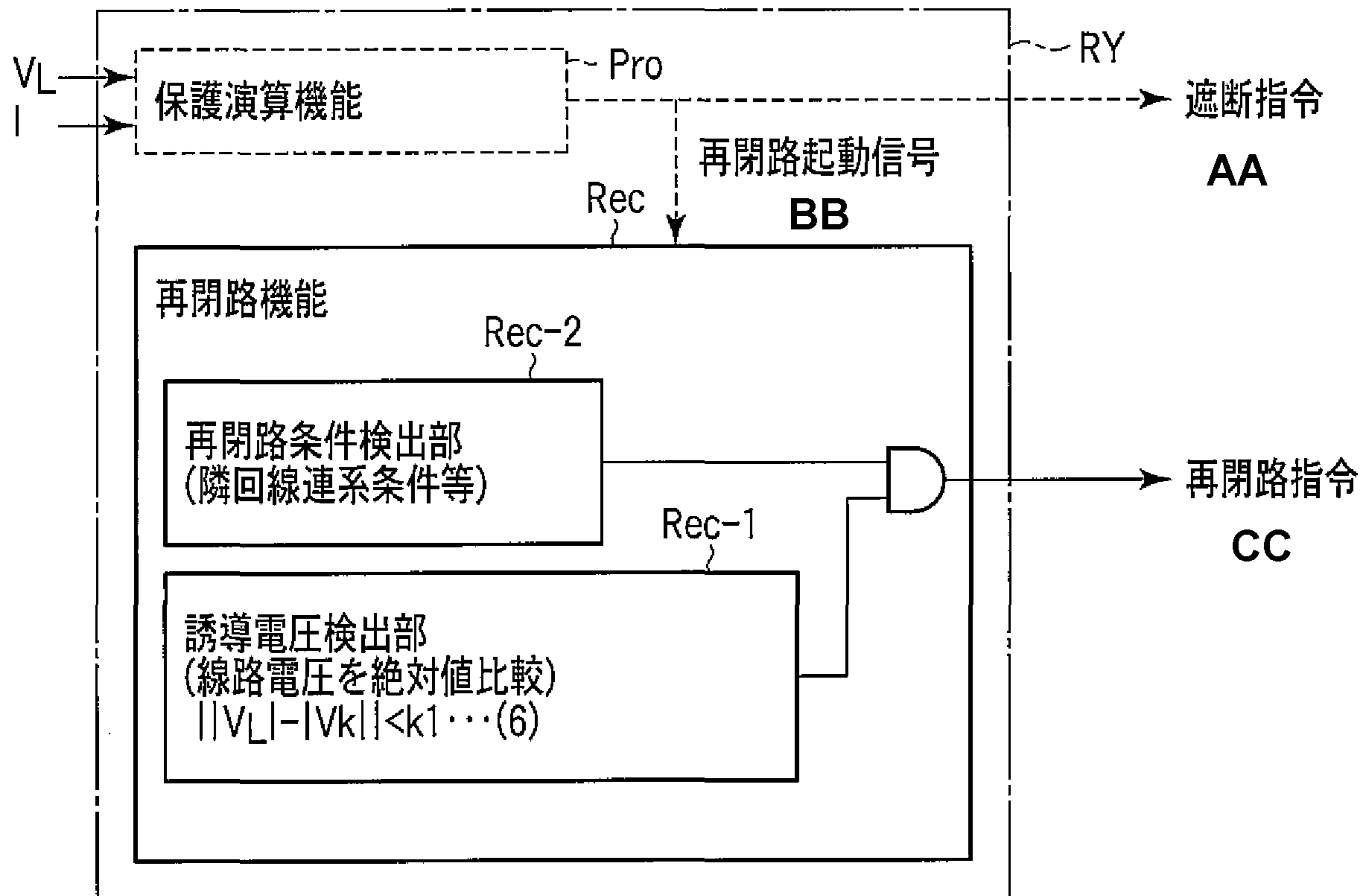

FIG. 20

[図4]



- AA Interrupt command
- BB Reclose startup signal
- CC Reclose command
- Pro Protection calculation function
- Rec Reclose function
- Rec-1 Induction voltage detection unit (comparison of absolute values of line voltages)
- Rec-2 Reclose condition detection unit (interconnection condition of adjacent lines, etc.)