

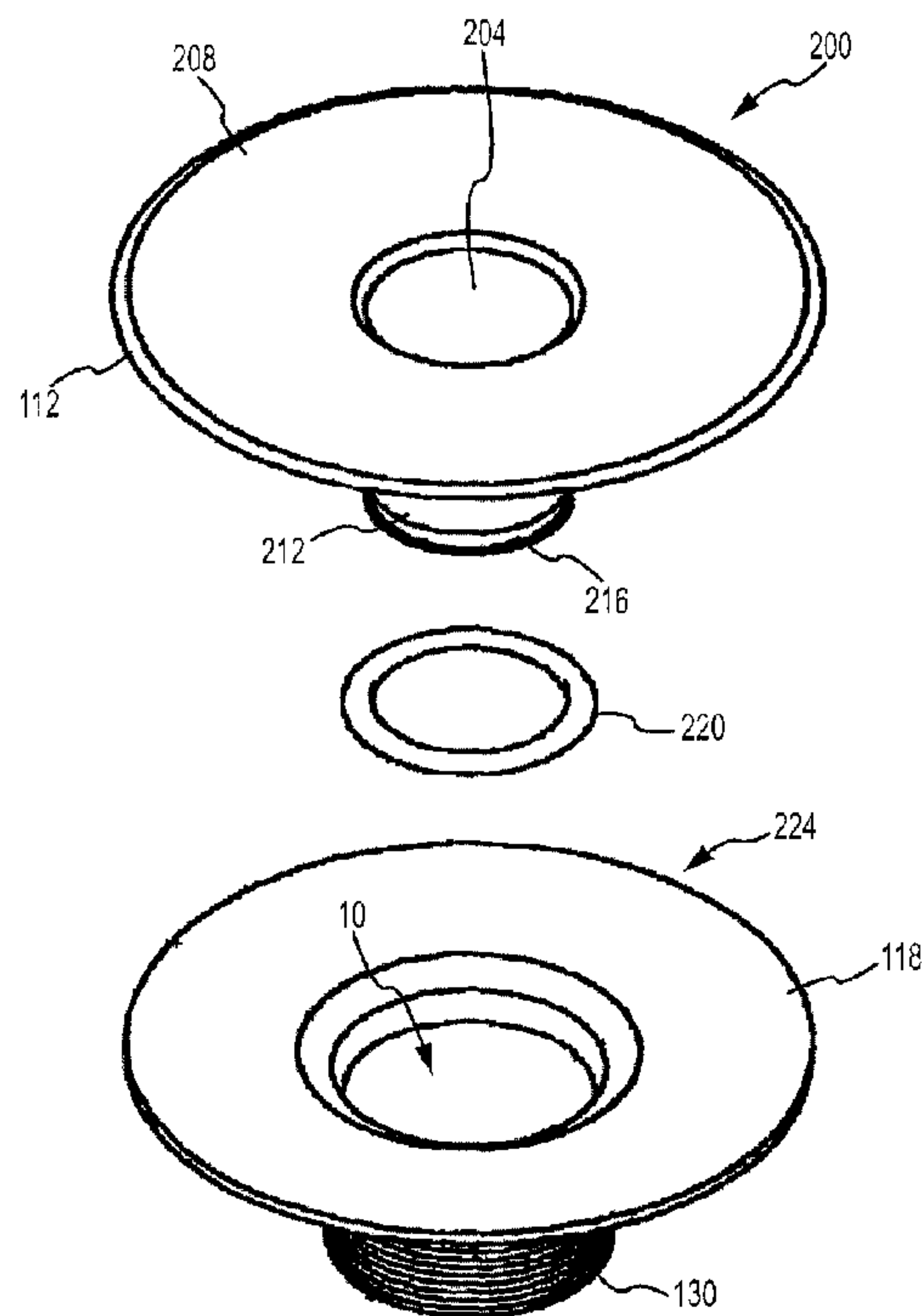

(22) Date de dépôt/Filing Date: 2008/10/30  
 (41) Mise à la disp. pub./Open to Public Insp.: 2009/04/30  
 (45) Date de délivrance/Issue Date: 2016/02/09  
 (62) Demande originale/Original Application: 2 642 379  
 (30) Priorité/Priority: 2007/10/31 (US11/931,681)

(51) Cl.Int./Int.Cl. *E03C 1/20* (2006.01),  
*E03C 1/24* (2006.01), *F16L 5/06* (2006.01),  
*F16L 55/115* (2006.01)  
 (72) Inventeur/Inventor:  
 BALL, WILLIAM T., US  
 (73) Propriétaire/Owner:  
 WCM INDUSTRIES, INC., US  
 (74) Agent: RICHES, MCKENZIE & HERBERT LLP

(54) Titre : METHODE ET EQUIPEMENT ASSOCIE PERMETTANT D'INSTALLER ET DE METTRE A L'EPREUVE UNE  
 INSTALLATION DE PLOMBERIE  
 (54) Title: METHOD AND ASSOCIATED APPARATUS FOR ASSEMBLING AND TESTING A PLUMBING SYSTEM



(57) **Abrégé/Abstract:**

A system is provided for enhancing the interconnectability of a bathtub to a plumbing system. More specifically, provided is a flexible conduit and an overflow assembly that allows for a portion of the overflow assembly to be easily located with the wall of a bathtub. The flexible conduit provided allows for adjustability of the conduit to the openings of the bathtub. In addition, provided are methods and apparatus that facilitate testing of a plumbing assembly. Finally, an apparatus and methods are provided that protect portions of the finished bathtub assembly to decrease in the need for replacing said hardware. It is envisioned that aspects and inventions disclosed herein can be used in conjunction to facilitate the interconnection and protection of hardware associated with a bathtub.

**ABSTRACT**

A system is provided for enhancing the interconnectability of a bathtub to a plumbing system. More specifically, provided is a flexible conduit and an overflow assembly that allows for a portion of the overflow assembly to be easily located with the wall of a bathtub. The flexible conduit provided allows for adjustability of the conduit to the openings of the bathtub. In addition, provided are methods and apparatus that facilitate testing of a plumbing assembly. Finally, an apparatus and methods are provided that protect portions of the finished bathtub assembly to decrease in the need for replacing said hardware. It is envisioned that aspects and inventions disclosed herein can be used in conjunction to facilitate the interconnection and protection of hardware associated with a bathtub.

## **FIELD OF THE INVENTION**

Embodiments of the present invention are generally related to components of a plumbing system that is used in conjunction with a bathtub, shower stall, since, etc. More specifically, embodiments of the present invention relate to a kit that includes devices that facilitate interconnection of the plumbing system to the bathtub, that allows for testing of the interconnection, and protects finished hardware associated with the bathtub.

## **BACKGROUND OF THE INVENTION**

During new building construction or renovation of an existing building structure, plumbers often must connect or reconnect bathroom fixtures to the plumbing system. Often plumbers find that interconnecting common bathroom fixtures, such as a bathtub, is difficult and time consuming. "Bathtubs" as referred to herein include a tub with a drain port and an overflow port such that if the drain port is plugged, water will flow into the overflow port and drain through the plumbing system and not out of the tub. Generally, the bathtub is interconnected to the plumbing system of a structure by a main drain pipe which associated to the drain port of the bathtub via a horizontal segment and which is associated with the overflow port of the bathtub via a vertical segment. These two drain segments merge at a tee connector that is also interconnected to the main drain pipe that feeds into a sewer line. During construction, the often heavy bathtub must be aligned

properly to interconnect with the drain pipe segment (horizontal) and the overflow pipe segment (vertical) of the drain pipe. Often the drain pipe segments are near a wall, awkwardly oriented, etc. and are thus difficult to associate with the bathtub.

Once the drain pipe segments are aligned with the bathtub, the drain pipes must usually be blocked for testing. In the past, a plug, bladder or cap has been employed to facilitate testing. Plugs and/or caps are easily misplaced, and are often difficult to install, thereby increasing the time and difficulty of testing a plumbing system.

Another drawback of bathtub assemblies of the prior art is that the finishing hardware generally associated with a drain of a bathtub often becomes damaged during construction. Traditionally, finishing hardware is interconnected to the bathtub drain port during construction since a rigid interconnection between the drain pipe and the bathtub is required. Thereafter, workers may damage the often expensive chrome or brass hardware by marring, scratching, or even urinating on the same. Thereafter the plumbing contractor must replace the finished hardware and retest the integrity of the new connection, which adds expense.

Thus it is a long felt need in plumbing to provide a system that facilitates the interconnection of a bathtub to a plumbing system, enhances the testing of the system and protects expensive hardware after the assembly is complete.

20

### **SUMMARY OF THE INVENTION**

Traditionally, an overflow system of a bathtub includes an overflow port that is interconnected to a vertical drain pipe via an elbow.

It is one aspect of the present invention to facilitate this interconnection by providing an elbow with a flange protruding therefrom. More specifically, embodiments of the present invention employ a flange that is spaced from an end of the elbow that will be associated with the bathtub. The end, thus, defines a shoulder that is adapted to receive a cylindrical adapter having an obstructed end that prevents the flow of fluid through the cylindrical fitting and elbow. In one embodiment, the cylindrical fitting includes exterior threads that receive a nut.

In operation, one end of the elbow is interconnected to the drain pipe and the other end, which is located adjacent to the flange, is placed within the perimeter of the overflow port such that the flange abuts an outer surface of the bathtub. The cylindrical fitting is then interconnected to the elbow which locates the other, closed end of the cylindrical fitting within the bathtub. The nut is used to sandwich the bathtub between the nut and the flange, thereby providing a generally rigid connection. Some embodiments of the present invention also employ a washer between the tub and the nut. The nut may also provide the ability to interconnect a decorative cap.

It is a related aspect of the present invention to selectively block fluid flow through the overflow assembly. More specifically, the closed portion of the cylindrical fitting acts as a plug to aid in testing of the plumbing system. After testing is complete the closed portion may be cut, or otherwise removed, to allow fluid flow through the overflow assembly. If additional testing is required traditional methods of plugging the overflow assembly may be employed, which will be described in further detail below.

It is another aspect of the invention to provide a method of installing a drain assembly that can be accomplished by a single individual. A related aspect of the invention is to provide a method of installing a bathtub drain assembly that allows for ease in field testing for leaks. Yet another aspect of embodiments of the present invention is to provide a method of installing the drain assembly that eliminates the need for the removal of a strainer body often associated with drain assemblies. In accordance with these and other aspects, one method includes inserting an L-shaped drain pipe having a threaded upper end and an annular flange covered by a membrane, through a drain port of the bathtub, such that the annular flange rests on a bottom surface of the bathtub. Next, a lock washer is threadingly engaged to the inner end of the drain pipe to the threaded portion. The other end of the L-shaped drain pipe is then connected to the drain system of the building. The assembly can then be tested for leaks. Once it is determined that no leaks are present, the membrane is removed from the flange on the upper end of the drain pipe. Finally, a finished cover is installed on the annular flange.

It is yet another aspect of the present invention to provide a bathtub drain pipe assembly that facilitates integration of the various drain pipes mentioned thus far to the bathtub. Embodiments of the present invention thus include a flexible hollow tube instead of rigid drain pipes that simplifies the installation of the bathtub to the plumbing system. The flexible tube of embodiments of the present invention has the added benefit of being easily modifiable and possesses a smooth inner surface to prevent the often unsanitary trapping of fluid with the flexible hollow tube.

It is still yet another aspect of the present invention to provide a protective cover that interconnects to the installed drain assembly. More specifically, a flange of the protective drain cover is superimposed over the flange of a waste water strainer located in a bathtub, sink or the like. A lip located about the outer perimeter of the flange of the  
5 cover fits over the outer periphery of the flange of the waste water strainer and centers the cover on the strainer. A cylindrical wall, which extends from the flange of the cover, is positioned downwardly through a cylindrical wall of the waste water strainer. The two cylindrical walls are spaced from each other by one or more seals that are positioned in grooves.

10 It is an aspect of the embodiment of the present invention to combine some or all of the above-described aspects to provide a system that facilitates interconnection of the bathtub to the plumbing system of a structure. More specifically, it is contemplated to use aspects described above, provided below, or apparent to one skilled in the art in conjunction to alleviate all of the difficulties noted above that are associated with  
15 interconnecting a bathtub to a plumbing system of a structure. For example, one skilled in the art will appreciate the overflow assembly can be easily integrated with the flexible pipes described above to expand the interconnection options available to a plumber. In addition, the protective drain cover may also be used. It is contemplated that the above described aspects of the present invention will provide a complete kit wherein all of the  
20 necessary components will be included to aid the plumber in interconnecting a bathtub to the plumbing of a structure, facilitate testing of the same and protecting fragile and

expensive components thereof, which will increase efficiency and decreasing costs of the operation.

In another aspect the present invention resides in a plumbing system for interconnection with a bathtub that has an overflow port and a drain port, comprising: an overflow assembly for interconnection with the overflow port that includes: an overflow pipe having a flange and a sleeve that extends outwardly from said flange, said sleeve having threads on an outer surface thereof; and a nut threadably mounted on said sleeve with the bathtub therebetween, wherein said nut exerts pressure on said flange, said nut having an outer periphery with a series of radially extending lugs that frictionally detachably engage an inner surface of a flange of a cap that fits over said nut, wherein said cap is selectively positioned on said nut to direct an overflow of water from the bathtub to said overflow pipe; a flexible pipe connected between said overflow assembly and said wastewater drain assembly, said flexible pipe being devoid of a valve operating mechanism; and a waste water insert for selective engagement with a strainer that is associated with a wastewater drain assembly, said insert comprising a wall with a cylindrical first portion and a cylindrical second portion with a conical portion therebetween, said cylindrical first portion having a diameter greater than a diameter of said cylindrical second portion, said wall surrounding a bore and having an upper end, and a flange on said upper end extending outwardly from said cylindrical bore; and the wall of said insert being spaced from cylindrical wall of the strainer wherein said cylindrical first portion being closer to said cylindrical wall of the strainer than said cylindrical second portion.

In a further aspect the present invention resides in a plumbing system for interconnection with a bathtub that has an overflow port and a drain port, comprising: an overflow assembly that includes: an overflow pipe with an elbow portion defining

an upper end portion, which is adapted for interconnection with the overflow port, and a lower end portion, which is adapted for interconnection with a wastewater drain assembly, said upper end portion having an outer end defining an inlet, said upper end having threads on an outer surface thereof; a lip extending radially outwardly from said outer surface of said overflow pipe between said elbow portion and said upper end portion and being spaced from said inlet; a nut element with a threaded portion that is compatible with said threads of said overflow pipe, said nut element having an outer periphery with a series of radially extending lugs that detachably engage an inner surface of a cap that fits over said nut; and a waste water insert for selective engagement with a strainer that is associated with the wastewater drain assembly.

In yet another aspect the present invention resides in a plumbing system for interconnection with a bathtub that has an overflow port and a drain port, comprising: an overflow assembly for interconnection with the overflow port, said overflow assembly comprising: an overflow pipe having a flange, said overflow pipe adapted to be associated with a threaded portion extending from said flange, said threaded portion adapted to pass through a wall of the bathtub and to be at least partially positioned within the bathtub; a means for preventing fluid flow through said overflow pipe that is associated with said threaded portion, said means for preventing fluid flow sealing an outer end of said threaded portion; a nut, having a threaded center opening, threadably mounted on said threaded portion of said overflow pipe, said nut being adapted to secure said flange to the wall of the bathtub by exerting pressure towards said flange; and said nut having an outer periphery with a series of radially extending cap retention elements which detachably engage an inner surface of a cap which fits over said nut; and a wastewater drain assembly for interconnection to the drain port.

The Summary of the Invention is neither intended nor should it be construed as being representative of the full extent and scope of the present invention. The present invention is set forth in various levels of detail in the Summary of the Invention as well as in the attached drawings and the Detailed Description of the Invention and no limitation as to the scope of the present invention is intended by either the inclusion or non-inclusion of elements, components, etc. in this Summary of the Invention. Additional aspects of the present invention will become more readily apparent from the Detail Description, particularly when taken together with the drawings.

#### **BRIEF DESCRIPTION OF THE DRAWINGS**

The accompanying drawings, which are incorporated in and constitute a part of the specification, illustrate embodiments of the invention and together with the general description of the invention given above and the detailed description of the drawings given below, serve to explain the principles of these inventions.

Fig. 1 is a partial perspective view of a bathtub;

Fig. 2 is a cross-sectional view of Fig. 1;

Fig. 3 is an exploded perspective view of an overflow assembly of one embodiment of the present invention;

Fig. 4 is a cross-sectional assembled view of the overflow assembly shown in Fig. 3;

Fig. 5 is an exploded perspective view of an alternate embodiment of an overflow assembly;

Fig. 6 is a cross-sectional, assembled view of the overflow assembly shown in Fig. 5;

5 Fig. 7 is a perspective view of a cylindrical fitting employed in overflow assemblies of some embodiments of the present invention;

Fig. 8 is an exploded view of an alternate embodiment of an overflow assembly that employs a one-piece overflow pipe and cylindrical fitting;

10 Fig. 9 is a perspective view of the one-piece overflow pipe and cylindrical fitting shown in Fig. 8;

Fig. 10 is an exploded perspective view of a drain assembly of one embodiment of the present invention;

Fig. 11 is a side elevation view of the drain assembly shown in Fig. 10 interconnected to the bathtub;

15 Fig. 12 is a side elevation view of a prior art interconnection horizontal and vertical drain pipes;

Fig. 13 is a perspective view of a flexible overflow pipe;

Fig. 14 is a side elevation view of the flexible conduit of Fig. 13 interconnected to the bathtub;

20 Fig. 15 is a side elevation of horizontal and vertical flexible conduits interconnected to the bathtub;

Fig. 16 is a partial perspective view of a bathtub showing a test cap interconnected to the overflow port;

Fig. 17 is a perspective view of a test cap of one embodiment of the present invention;

5 Fig. 18 is a cross-sectional view of the test cap of Fig. 17 interconnected to an overflow pipe;

Fig. 19 is a perspective view of an alternative embodiment of a test cap;

Fig. 20 is a cross-sectional view of the test cap of Fig. 19 shown interconnected to an overflow pipe;

10 Fig. 21 is a side elevation view of an alternative embodiment of the test cap interconnected to an overflow pipe;

Fig. 22 is a front elevation view of another embodiment of the test cap having a removable diaphragm;

Fig. 23 is a rear perspective view of the test cap shown in Fig. 22;

15 Fig. 24 is a perspective view of a protective cover and drain;

Fig. 25 is a cross-sectional view of the protective cover shown in Fig. 23; and

Fig. 26 is a cross-sectional view of an alternate embodiment of the protective cover.

To assist in the understanding of the present invention the following list of components and associated numbering found in the drawings is provided herein:

	<u>#</u>	<u>Component</u>	<u>#</u>	<u>Component</u>
5	2	Overflow assembly	106	Opening
	6	Bathtub	110	Drain assembly
	10	Drain port	112	Edge
	14	Overflow port	114	Tub floor
	18	Elbow	118	Drain pipe flange
10	22	Overflow pipe	122	Nut
	26	Tee connector	126	Cylindrical portion
	30	First end	130	Threads
	34	Second end	134	Drain pipe
	38	Flange	138	Membrane
15	42	Shoulder	140	Cover
	46	Cylindrical fitting	144	Drain closure
	50	Threads	176	Test cap
	54	Diaphragm	180	Cylindrical body
	58	Outer surface	184	Flange
20	62	Wall	188	Face
	66	Inner surface	192	Interior threads
	70	Washer	196	Inner surface

<u>#</u>	<u>Component</u>	<u>#</u>	<u>Component</u>
74	Nut	200	Protective cover
78	Lug	204	Opening
82	Threads	208	Flange
5 86	Cap	212	Tubular wall
90	Notch	216	Groove
94	Protrusions	220	Seal
98	Ring	224	Strainer
102	Cutting tool		

10

It should be understood that the drawings are not necessarily to scale. In certain instances, details which are not necessary for an understanding of the invention or which render other details difficult to perceive may have been omitted. It should be understood, of course, that the invention is not necessarily limited to the particular embodiments

15 illustrated herein.

### DETAILED DESCRIPTION

Referring now to Figs. 1-9 an overflow assembly 2 adapted for interconnection to a bathtub 6 is provided. The overflow assembly 2 is adapted to be used in conjunction  
20 with a bathtub 6 having a drain port 10 and an overflow port 14. The overflow port 14 receives an L shaped elbow 18 that leads into an overflow pipe 22 that eventually feeds into a tee-connector 26. The tee-connector 26 also receives fluid from the drain port 10

of the bathtub 6 and has an opening that connects to the sewer system of the structure.

Turning now specifically to Figs. 2-4, an overflow assembly of one embodiment of the present invention is provided. Here, the elbow 18 includes a first end 30 and a second end 34 wherein a flange 38 is spaced from the first end 30. Thus, the first end 30  
5 comprises a lip that protrudes from the flange 38. The first end 30 is adapted to receive a shoulder 42 of a cylindrical fitting 46 that also includes an outer surface with a plurality of threads 50 and may have a diaphragm 54 situated on one end thereof.

In operation, the flange 38 is adapted to abut an outer surface 58 of the bathtub 6, thereby placing the first end 30 at least partially within the thickness of the bathtub wall  
10 62 or away from an inner surface 66 of the bathtub 6 which facilitates alignment of the overflow port and the overflow assembly 2. After the elbow 18 is properly aligned and engaged within the overflow port 14 of the bathtub 6, the cylindrical fitting 46 is interconnected thereto wherein the shoulder 42 is placed in contact with the first end 30 of the elbow 18. A washer 70 is then placed around the cylindrical fitting 46 and in  
15 abutting relationship with the inner surface 66 of the bathtub 6. A nut 74 having a plurality of externally protruding lugs 78 and internal threads 82 is then screwed on to the threads 50 of the cylindrical fitting 46, thereby sandwiching the wall 62 of the bathtub 6 between the flange 38 and the washer 70. The lugs 78 of the nut 74 are adapted to receive an inner surface of a cap 86. The cap 86 also employs at least one notch 90 that allows  
20 for water to flow from the cap 86 through the elbow 18 and into the overflow pipe 22 of the plumbing system.

After the overflow system is interconnected to the bathtub, testing it is often

required. Often such testing of the overflow assembly 2 must be blocked. Thus, as  
briefly described above, the cylindrical fitting 46 may include a diaphragm 54 that  
prevents flow of liquid therethrough. After testing is complete the diaphragm 54 may be  
cut away to provide a flow path from the notch 90 of the cap 86 into the elbow 18. No  
5 additional hardware, such as a test cap, is needed to perform testing.

Referring now to Figs. 5 and 6, an alternate embodiment of an overflow assembly  
2 is provided. More specifically, the nut 74 described above includes a plurality of  
protrusions 94 aligned on a ring 98 that is positioned adjacent to the plurality of the lugs  
78. The protrusions 94 allow for enhanced interconnectability between the nut 74 and the  
10 cylindrical fitting 46 by providing a plurality of finger holds.

Referring now to Fig. 7, the cylindrical fitting 46 of the overflow assembly 2 of  
one embodiment of the present invention is provided. As mentioned above, it is often  
desirable to maintain the integrity of the overflow assembly 2 such that fluids or air are  
maintained within the plumbing assembly, i.e. plugged. After any required testing is  
15 complete, a cutting tool 102 is employed to remove the diaphragm 54 of the cylindrical  
fitting 46, thereby providing an opening 106 for fluids.

Referring now to Figs. 8 and 9, yet another variation of the above-identified  
overflow assembly is provided. Here, a one-piece unit is provided wherein the cylindrical  
fitting 46 and the elbow 18 are rigidly interconnected. In addition, one skilled in the art  
20 will appreciate that at least a portion of the overflow pipe 22 may also be rigidly  
interconnected to the elbow 18. This configuration omits at least two joints in the system,  
which reduces the likelihood of leaks between components. One skilled in the art will

also appreciate that a diaphragm may also be included in this embodiment of the present invention that is cut away to provide an opening 106 after testing is performed.

Referring now to Figs. 10 and 11, the drain assembly 110 for interconnecting the bathtub to the plumbing system of one embodiment of the present invention is shown.

5 Here, similar to the overflow assembly, the drain assembly must be rigidly interconnected to the bathtub 6. Thus embodiments of the present invention employ a drain assembly 110 wherein the tub floor 114 is sandwiched between a drain pipe flange 118 and a nut 122. In operation, the drain pipe flange 118 includes a cylindrical portion 126 extending therefrom that includes a plurality of threads 130. The drain pipe flange 118 is mated  
10 with a drain pipe 134 wherein the nut 122 is threaded on the drain pipe 134 prior to the marriage of the cylindrical portion 126 and the drain pipe 134. The nut 122 is brought up to the threads 130 and tightened such that the tub floor is sandwiched between the drain pipe flange 118 and the nut 122 to secure the drain assembly to the drain port 10 of the bathtub 6. To test the system a membrane 138 may be employed to block flow to the  
15 drain pipe 134. After testing is completed, a cover 140 and drain closure 144, which are common in the art, may be incorporated.

Referring now to Figs. 12-15, a method of facilitating interconnection of the overflow pipe 22 and the drain pipe 134 is provided. Fig. 12 shows the prior art method of interconnecting drain pipes and flow pipes to a bathtub 6 wherein the rigid overflow  
20 pipe 22 is interconnected to the elbow 18 of the overflow assembly 2 and a rigid drain pipe 134 is horizontally interconnected from a connector associated with the drain port 10. These two rigid pipes merge at a tee-connector 26 and into the main drain pipe of the

plumbing system. As one skilled in the art will appreciate, interconnection of these rigid pipes is often difficult, especially when they are misaligned due to engineering errors or errors in interconnecting of the individual pipes to the tee-connectors 26, for example. Often, the interconnection of the bathtub to the overflow pipe 22 and drain pipe 134 will  
5 cause frustration, delays and increased costs.

Referring now to Figs. 13 and 14, this problem has been addressed by an embodiment of the present invention that provides a flexible conduit 148 that leads from the elbow 18 of the overflow assembly 2 to the tee-connector 26. It is envisioned that the flexible conduit 148 of this embodiment of the present invention be corrugated, however,  
10 be not susceptible to the drawbacks of using a corrugated tube. More specifically, as one skilled in the art will appreciate, the use of corrugated tubing, to allow for selective adjustments of tube bends is common. However, the use of a corrugated surface is not desirable and is often counter building codes since waste and fluid can gather in the corrugations provided in the inner diameter of the conduit thereby providing a breeding  
15 ground for a mold and germs. Thus the flexible conduit 148 of embodiments of the present invention employ a coating that maintains flexibility but yet eliminates at least the corrugations in the inner surface of the flexible conduit 148.

Referring now specifically to Fig. 15, the flexible conduit 148 as described above may be employed in another way. That is, Fig. 14 shows the flexible conduit 148  
20 extending from the overflow assembly 2 into the tee-connector 26 that is associated directly with the drain port 10. More often, it is desirable to provide a vertical overflow pipe 22 and a horizontal drain pipe 134. These pipes may be made of the flexible conduit

as described above and interconnected as traditionally done to the tee-connector 26 that is associated with the main drain pipe of the plumbing system. Since the flexible conduit 148 as provided is pliable, it is easily cut. Thus plumbers may use the flexible conduit 148 as they would use rigid conduit and selectively cut them to lengths to interconnect to traditionally located tee-connectors 26.

Referring now to Figs. 16-23, a test cap 176 of one embodiment of the present invention is provided. As mentioned above, it is often desirable to plug the overflow port 14 and/or drain port 10 of the bathtub to facilitate testing. As also described above, this is most preferably done with a diaphragm that omits the need for a test cap 176. However, if testing needs to be performed subsequent to removal of a diaphragm, a test cap 176 can be used.

Referring now to Figs. 17 and 18, a test cap 176 of one embodiment of the present invention is provided with a cylindrical body 180 having a flange 184 positioned thereon.

The flange 184 has a face 188 that receives a diaphragm 54 and includes internally located threads 192 that receive the threads of the cylindrical fitting 42 of the overflow assembly 2, similar to that described above. The test cap 176 of this nature can be used on overflow assemblies as described above that include a diaphragm 54 if further testing is required. After testing is completed, the diaphragm 54 of the test cap 176 of this embodiment of the present invention may be cut away to provide an opening 106 as described above.

Referring now to Figs. 19 and 20 a test cap 176 of one embodiment of the present invention is shown. Here, a traditional plug having threads is used. However, this

embodiment of the present invention also includes a diaphragm 54 positioned on one end that may be cut-away after testing is complete.

Referring now to Figs. 21-23, yet another version of the test cap 176 is provided with an inner surface 196 of malleable material that helps seal the interconnection of the test cap 176 and the overflow elbow 18. That is, by interconnecting the test cap 176 onto the external threads of the overflow elbow 18, the end of the overflow assembly 2 will deform the inner surface of the test cap 176 somewhat to create a seal. It is also envisioned that a test cap 176 of this embodiment of the present invention employs a diaphragm 54 that can be cut away if needed.

Referring now to Figs. 24-26, a protective drain cover 200 is provided. Here, the protective cover 200 having an opening 204 therethrough and a flange 208 is shown. Emanating from the flange 208 is the tubular wall 212 having a groove 216 positioned therearound. The groove 216 is adapted to receive at least one seal 220. The protective cover 200 is adapted to be associated with a strainer 224 of the drain assembly 110, thereby positioning the flange 208 of the protective cover 200 over the flange 118 of the drain assembly 110. In addition, the protective cover 200 includes an edge 112 that slightly curves downwardly to protect an edge of the strainer 224. As described above, the strainers 224 are often made of a brass or chrome which is easily damaged. Thus in operation, the tubular wall 212 of the drain cover 200 feeds into an opening of the strainer 224. The seals 220 are then disposed between the outer surface of the tubular wall 212 and the inner surface of the strainer 224. Thus the drain assembly 110 is protected during

construction. After construction is completed, the protective cover 200 is removed and the drain assembly 110 remains within the bathtub 6.

While various embodiments of the present invention have been described in detail, it is apparent that modifications and alterations of those embodiments will occur to those skilled in the art. However, it is to be expressly understood that such modifications and alterations are within the scope of the present invention, as set forth in the following claims

We Claim:

1. A plumbing system for interconnection with a bathtub that has an overflow port and a drain port, comprising:

an overflow assembly that includes: an overflow pipe with an elbow portion defining an upper end portion, which is adapted for interconnection with the overflow port, and a lower end portion, which is adapted for interconnection with a wastewater drain assembly, said upper end portion having an outer end defining an inlet, said upper end having threads on an outer surface thereof;

a lip extending radially outwardly from said outer surface of said overflow pipe between said elbow portion and said upper end portion and being spaced from said inlet;

a nut element with a threaded portion that is compatible with said threads of said overflow pipe, said nut element having an outer periphery with a series of radially extending lugs that detachably engage an inner surface of a cap that fits over said nut; and

a waste water insert for selective engagement with a strainer that is associated with the wastewater drain assembly.

2. The system of claim 1 wherein said overflow assembly further comprises a means for preventing fluid flow through said overflow pipe.

3. The system of claim 2, wherein said means for preventing fluid flow is a selectively removable diaphragm.

4. The system of claim 1, further comprising a washer associated with said upper end of said overflow pipe such that said washer is adapted to be positioned between the wall of the bathtub and said nut element.

5. The system of claim 1 wherein said waste water insert has a groove that receives a resilient ring.

6. The system of claim 1, wherein said waste water insert comprises a wall with a cylindrical portion having an upper end with a flange extending outwardly from said cylindrical portion, said flange having a downwardly-extending lip associated with the outer edge thereof, said lip adapted to engage an outer edge of a flange of the wastewater strainer.

7. A plumbing system adapted for interconnection with a bathtub that has an overflow port and a drain port, comprising:

an overflow pipe with: an elbow portion defining an upper end portion, which is adapted for interconnection to the overflow port, and a lower end portion, said upper end portion having an outer end defining an inlet and having threads on an outer surface thereof;

a lip extending radially outwardly from said outer surface of the overflow pipe between said elbow portion and said upper end portion and being spaced from the inlet;

a nut element with a threaded portion that is compatible with said threads associated with said inlet for mounting said nut element to said upper end portion, said nut element having a plurality of lugs extending radially from said nut element wherein said nut element and said plurality of lugs constitute a single-piece unit;

a cap detachably interconnected to at least one of said plurality of lugs and covering said nut element;

a wastewater drain assembly adapted for interconnection to the drain port and to the lower end portion of said overflow pipe, said drain assembly including a drain pipe having an upper end with an annular flange for resting on a bottom wall of the bathtub, and a means for locking slidably received by, and threadingly engaged, to said drain pipe, wherein

tightening said means for locking against an outer surface of the bottom wall of the bathtub secures said wastewater drain assembly to the bathtub; and

a waste water insert for selective engagement with a strainer that is associated with the wastewater drain assembly.

8. The system of claim 7, wherein said waste water insert comprises a wall with a cylindrical portion having an upper end with a flange extending outwardly from said cylindrical portion, said flange having a downwardly-extending lip associated with the outer edge thereof, said lip adapted to engage an outer edge of a flange of the wastewater strainer.

9. The system of claim 7, further comprising a sealing element associated with said outer end that closes said inlet to fluid flow.

10. The system of claim 9, wherein said overflow pipe and said sealing element is a one-piece construction.

11. The system of claim 9, further including a washer that cooperates with said nut and said lip to interconnect said overflow pipe to the bathtub.

12. The system of claim 9, wherein said sealing element is a diaphragm.

13. A plumbing system for interconnection with a bathtub that has an overflow port and a drain port, comprising:

an overflow assembly for facilitating leak testing of a plumbing system that is adapted to be associated with a bathtub, comprising:

an overflow pipe including an upper and a lower end;

an elbow between said upper end and said lower end, said upper end having threads and being adapted to fit completely through an overflow port of the bathtub;

a lip extending radially outwardly from an outer surface of the overflow pipe between said elbow and said upper end that is adapted to engage an outer surface of the bathtub adjacent to the overflow port;

a nut element associated with said overflow pipe adapted to secure said overflow pipe to an end of the bathtub wherein a wall of the bathtub is positioned between said lip and said nut element, said nut element comprising threads compatible with said threads of said upper end and said nut element having a plurality of cap retention elements extending radially from said nut element; and

a cap selectively interconnected to said nut element;

a wastewater drain assembly for interconnection to the drain port; and

a waste water insert for selective engagement with a strainer that is associated with the wastewater drain assembly.

14. The system of claim 13, wherein said waste water insert comprises a wall with a cylindrical portion having an upper end with a flange extending outwardly from said cylindrical portion, said flange having a downwardly-extending lip associated with the outer edge thereof, said lip adapted to engage an outer edge of a flange of the wastewater strainer.

15. A plumbing system for interconnection with a bathtub that has an overflow port and a drain port, comprising:

an overflow assembly for adapted for interconnection to a bathtub, which has a bottom, side walls, end walls, and the overflow port in one end wall, comprising:

an overflow pipe having an elbow portion defining an upper end portion and a lower end portion, said upper end portion having an outer end defining an inlet and having threads on an outer surface thereof;

a lip extending radially outwardly from said outer surface of said overflow pipe between said elbow portion and said upper end portion and being spaced from said inlet;

a nut element with a threaded portion that is compatible with said threads of said overflow pipe for mounting said nut element to said upper end portion, said nut element having a series of radially extending cap retention elements that are spaced about a longitudinal axis defined by said nut element, there being gaps between each of said radially extending cap retention elements; and

a cap retained in a position of attachment to said radially extending cap retention elements, said radially extending cap retention elements being received within said cap;

a wastewater drain assembly for interconnection to the drain port; and

a waste water insert for selective engagement with a strainer that is associated with the wastewater drain assembly.

16. The system of claim 13, wherein said waste water insert comprises a wall with a cylindrical portion having an upper end with a flange extending outwardly from said cylindrical portion, said flange having a downwardly-extending lip associated with the outer edge thereof, said lip adapted to engage an outer edge of a flange of the wastewater strainer.

17. The assembly of claim 15, wherein said cap covers substantially all of said nut element.

18. The assembly of claim 15, wherein said cap defines a fluid passing passage.

19. The assembly of claim 15, wherein said cap is in spaced relation to said nut element and is in sealing engagement with said inlet.

20. The assembly of claim 15, wherein said cap is adjustably retained to said nut element by the radially extending lugs that engage an inner surface of the cap.

21. A plumbing system for interconnection with a bathtub that has an overflow port and a drain port, the plumbing system also associated with a waste water strainer, said strainer having a cylindrical wall with a bottom edge surrounding a cylindrical opening extending through the bottom of the bathtub, and a flange extending outwardly from a level above and adjacent said cylindrical opening and positioned on the bottom of the bathtub, comprising:

an overflow assembly for adapted for interconnection to a bathtub, which has a bottom, side walls, end walls, and the overflow port in one end wall, comprising:

an overflow pipe having an elbow portion defining an upper end portion and a lower end portion, said upper end portion having an outer end defining an inlet and having threads on an outer surface thereof;

a lip extending radially outwardly from said outer surface of said overflow pipe between said elbow portion and said upper end portion and being spaced from said inlet;

a nut element with a threaded portion that is compatible with said threads of said overflow pipe for mounting said nut element to said upper end portion, said nut element having a series of radially extending cap retention elements that are spaced about a longitudinal axis defined by said nut element, there being gaps between each of said radially extending cap retention elements; and a cap retained in a position of attachment to said radially extending cap retention elements, said radially extending cap retention elements being received within said cap; and

a waste water insert adapted for insertion within the wastewater strainer and comprising a wall with a cylindrical portion having an upper end with a flange extending outwardly from said cylindrical portion, said flange having a downwardly-extending lip

associated with the outer edge thereof, said lip adapted to engage an outer edge of the flange of the wastewater strainer

22. The combination of claim 21, further comprising a resilient member associated with the outer surface of said cylindrical wall of said insert.

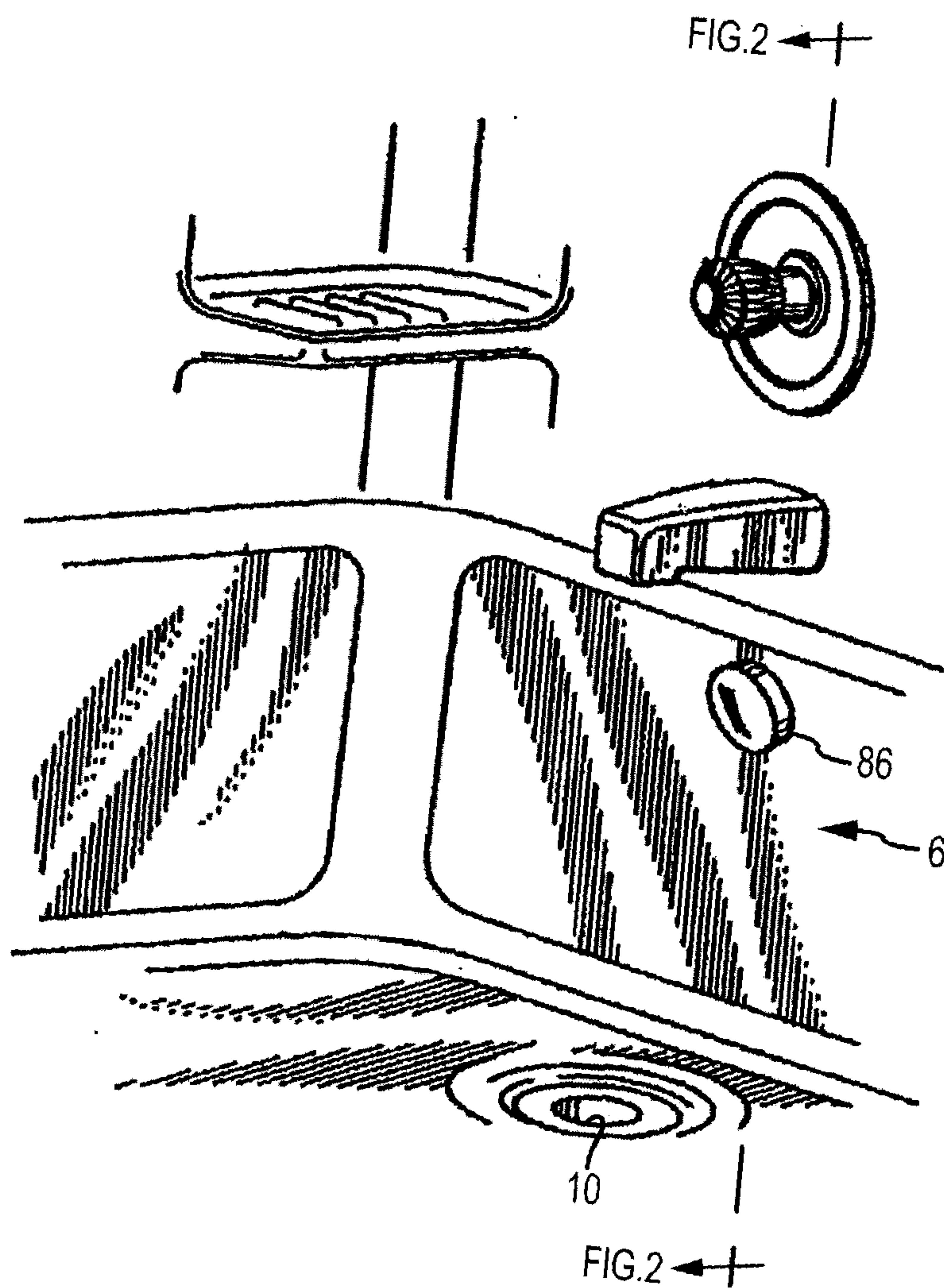

FIG. 1

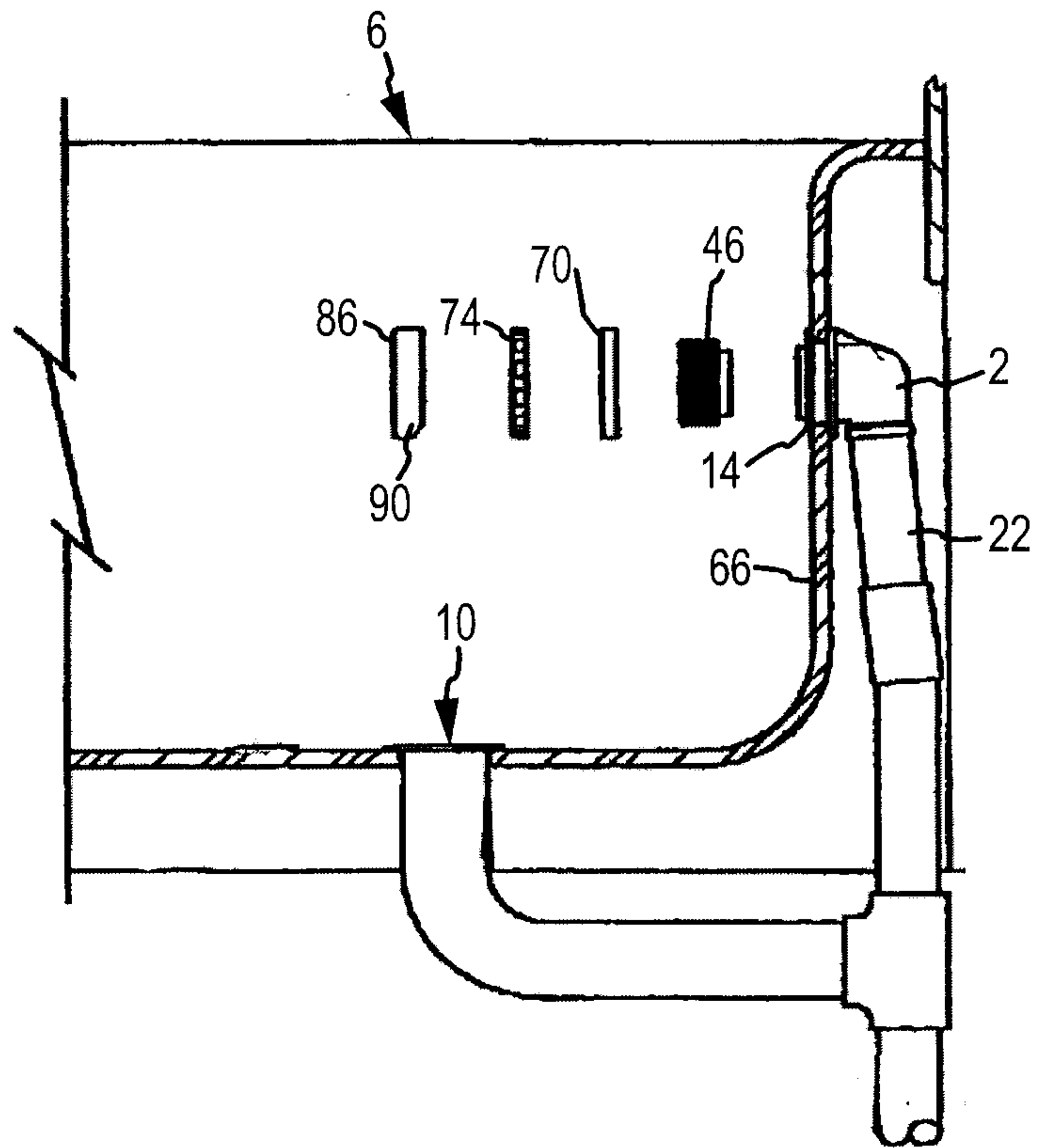

FIG.2

3/23

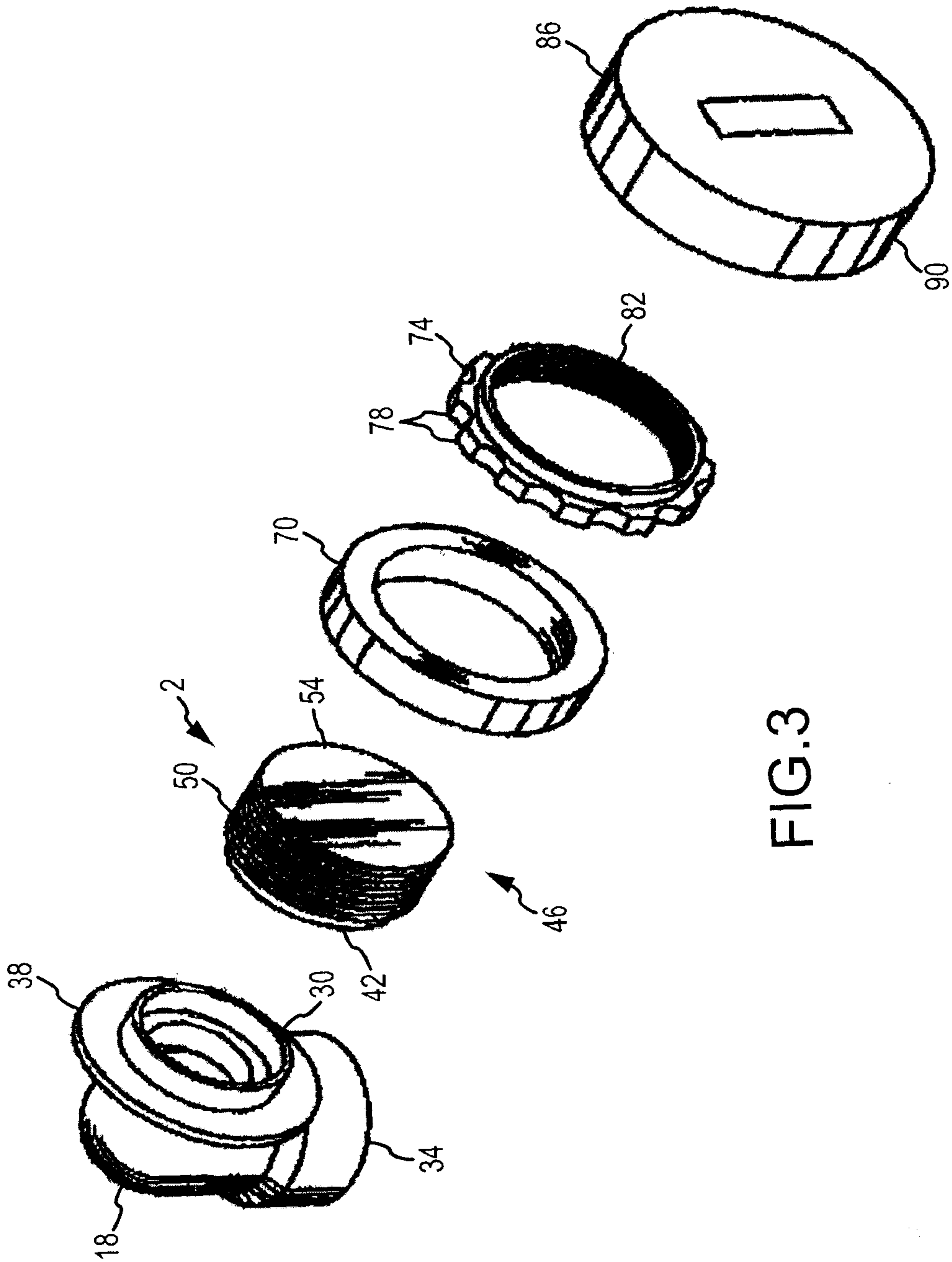
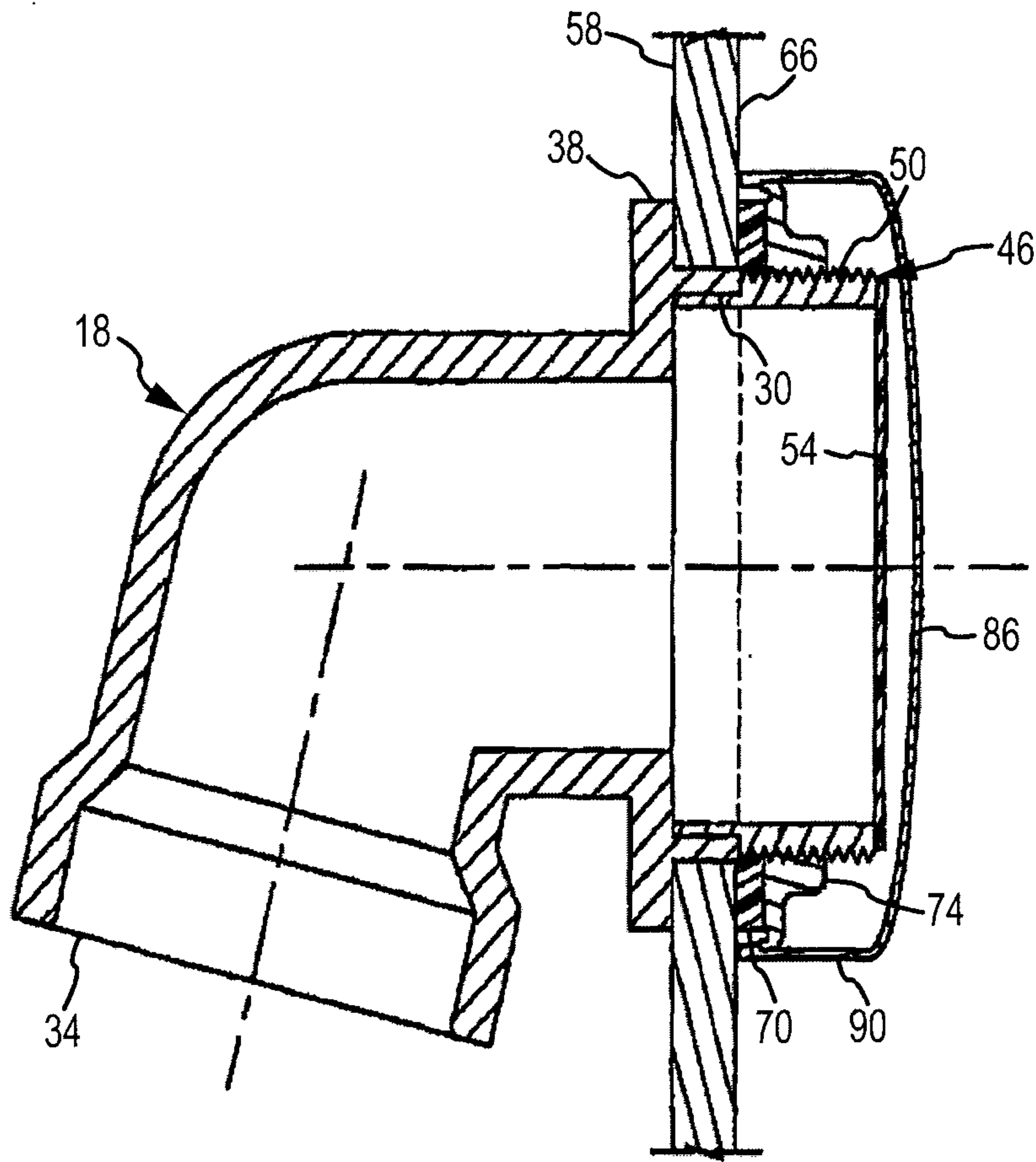

FIG.3



5/23

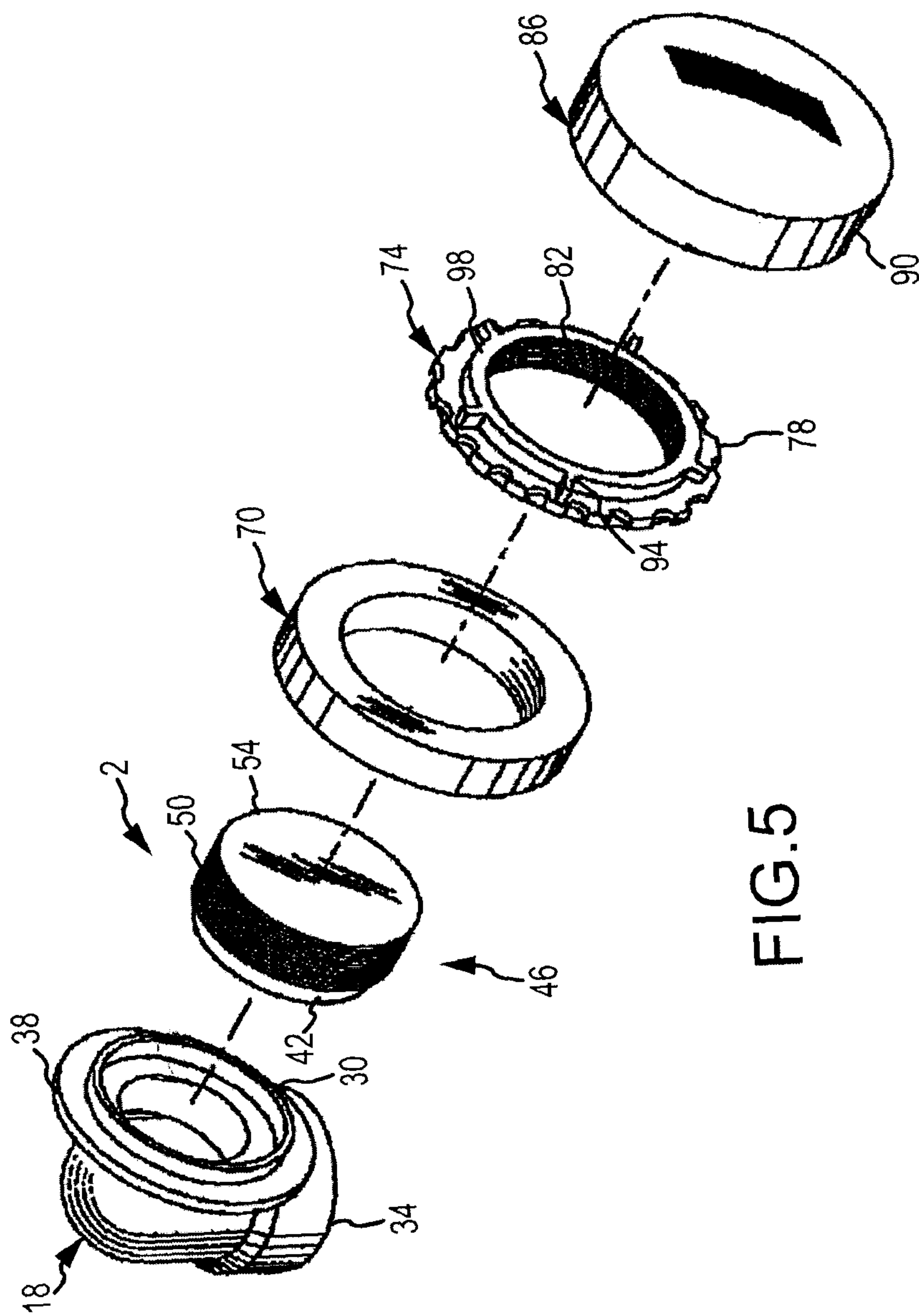

FIG.5

6/23

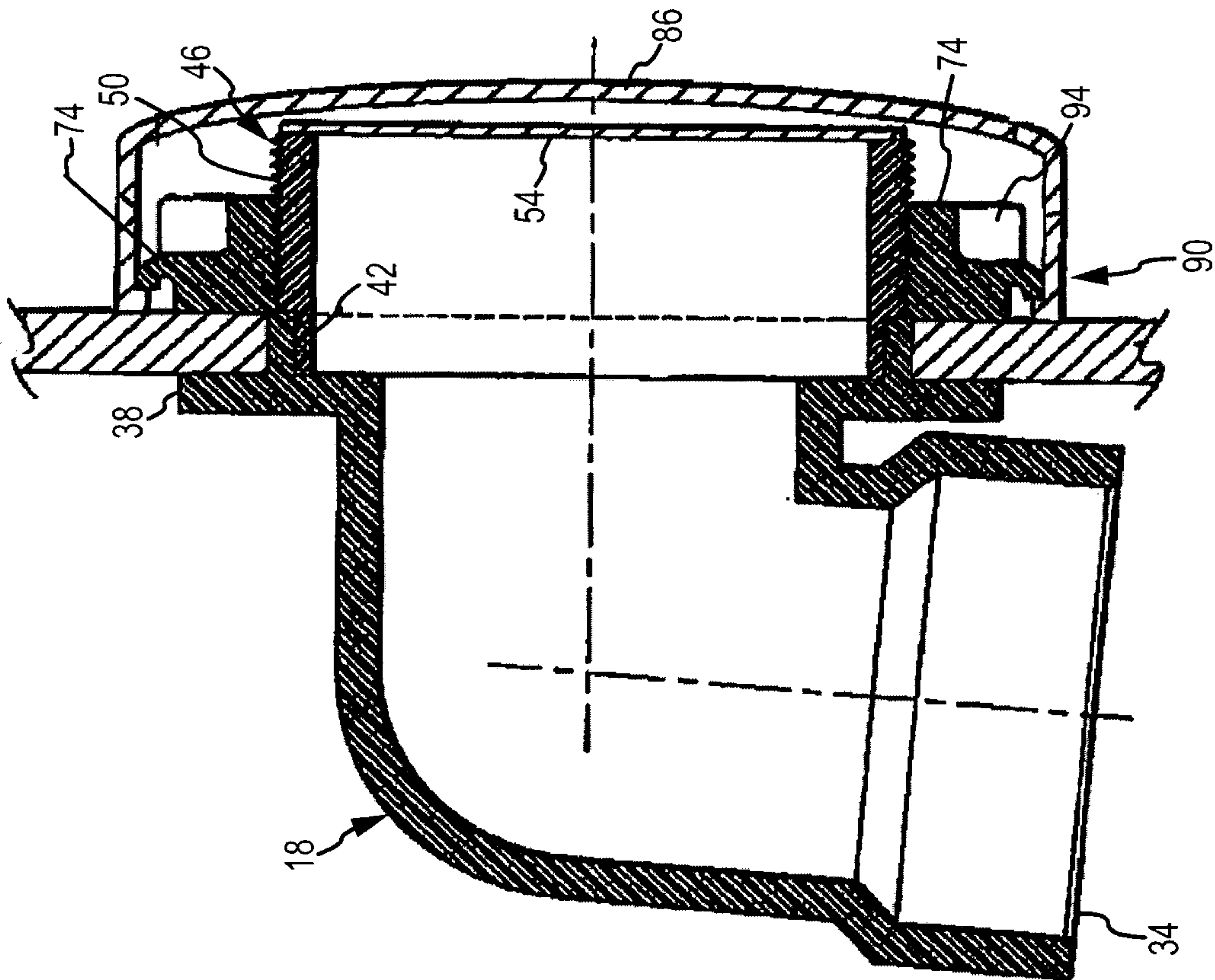

FIG. 6

7/23

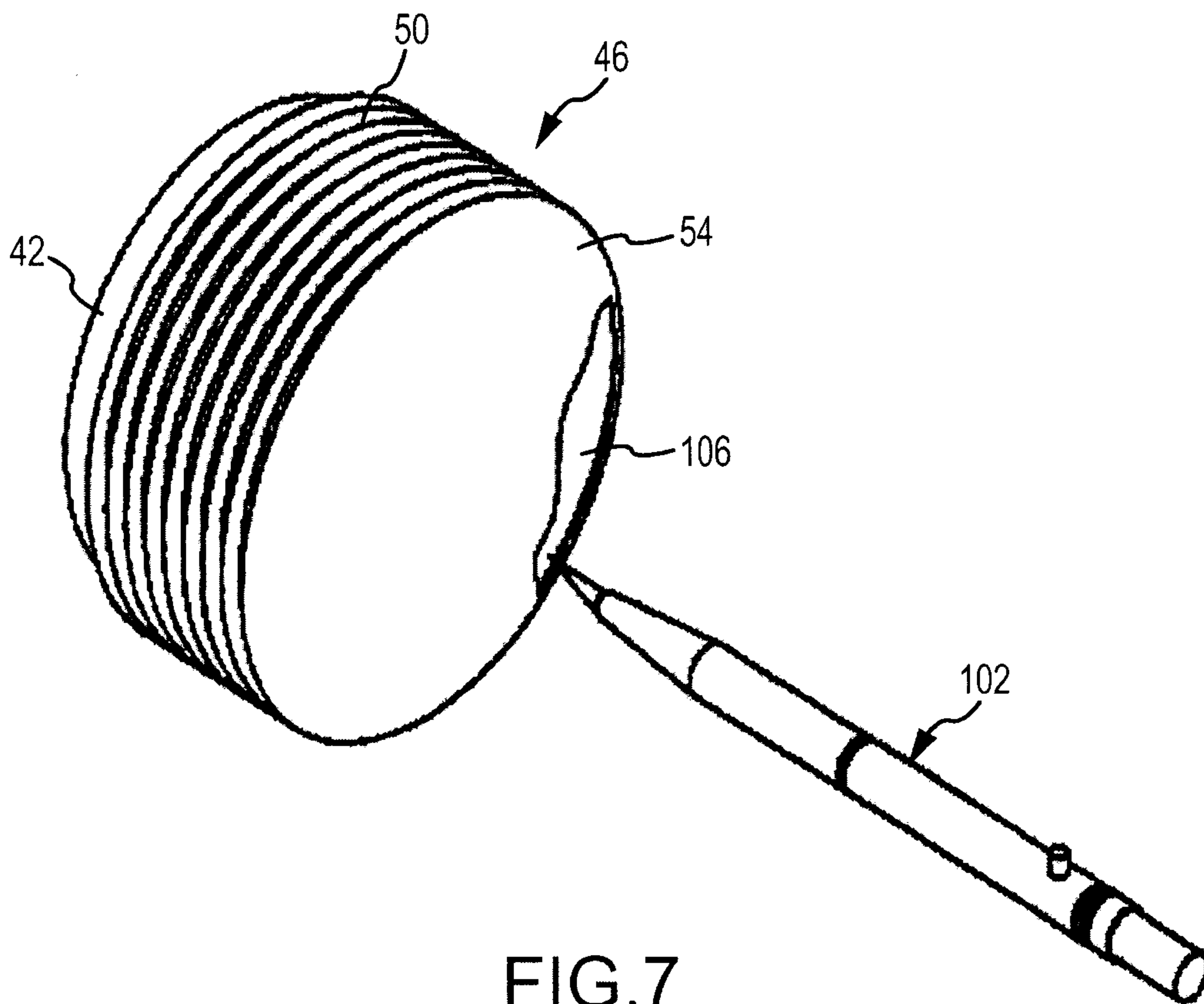

FIG.7

8/23

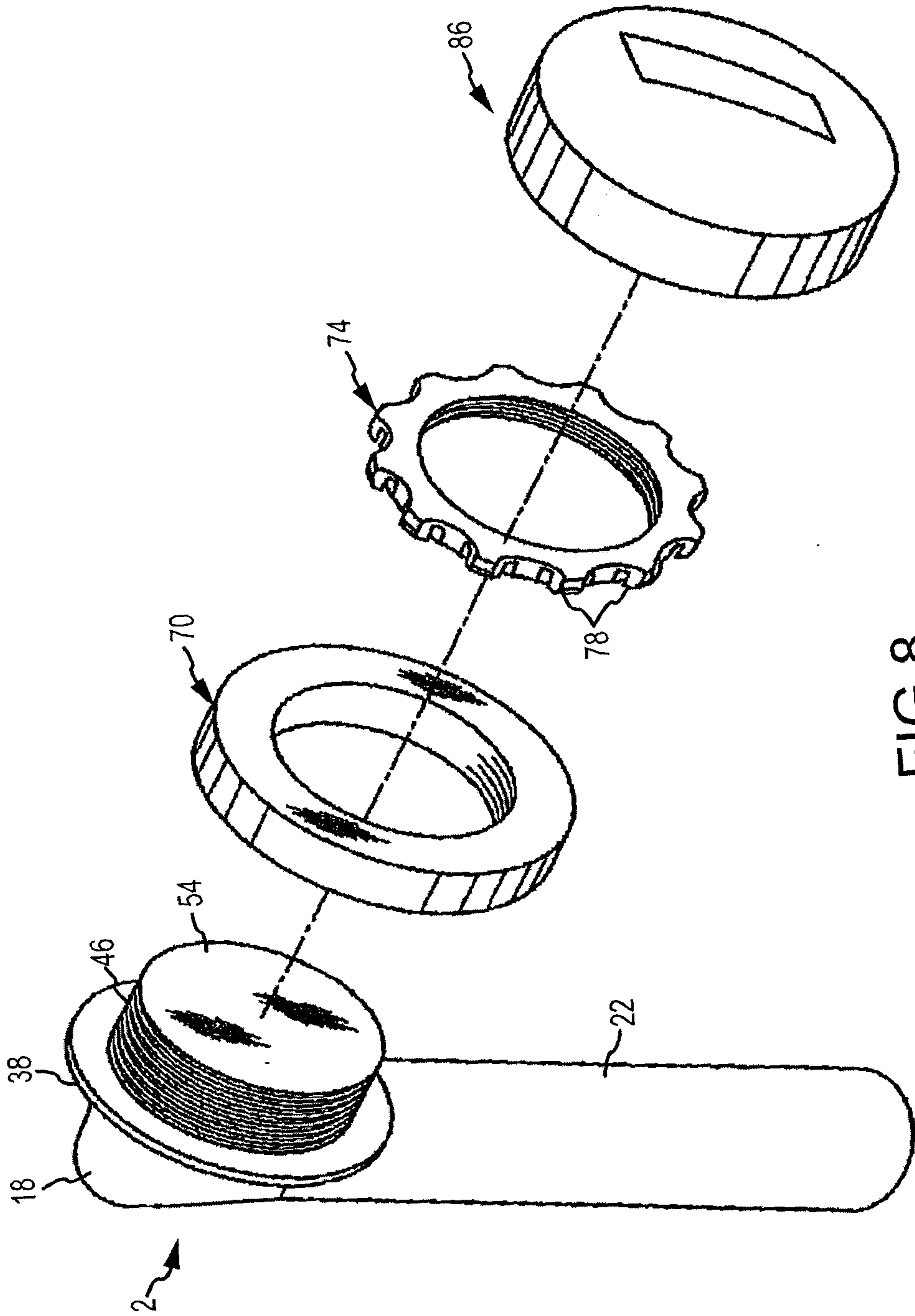

FIG.8

9/23

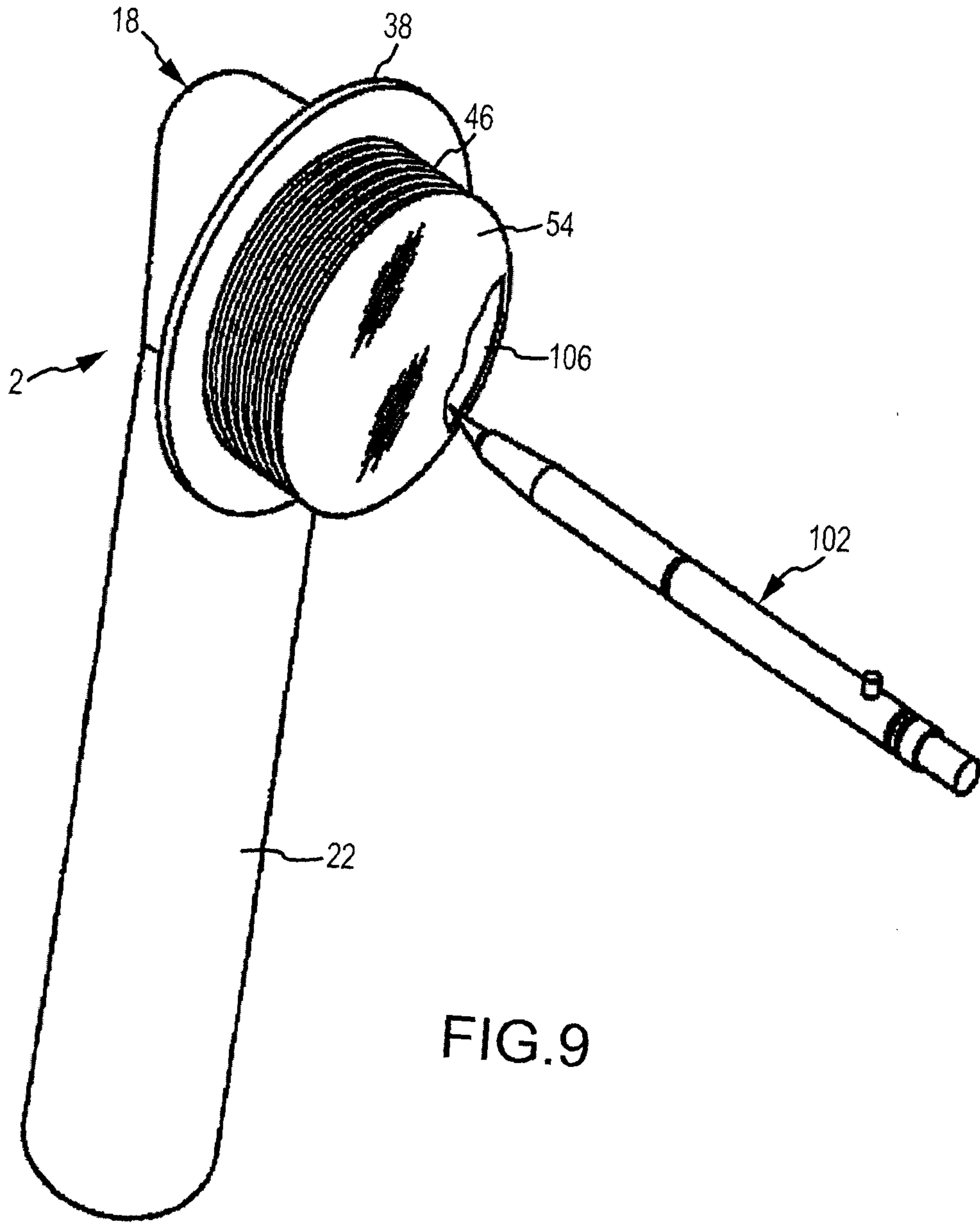

FIG. 9

10/23

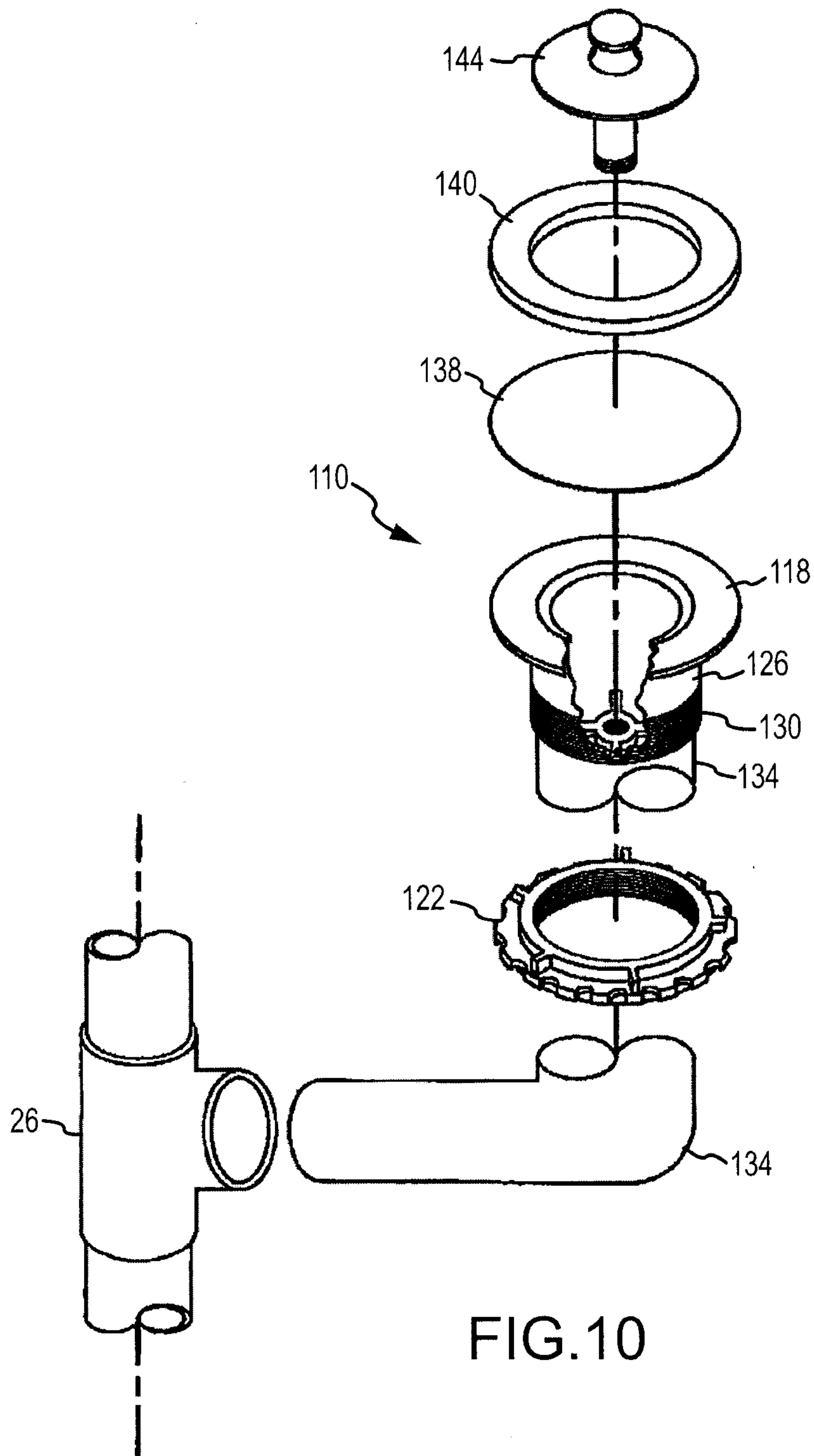

FIG.10

11/23

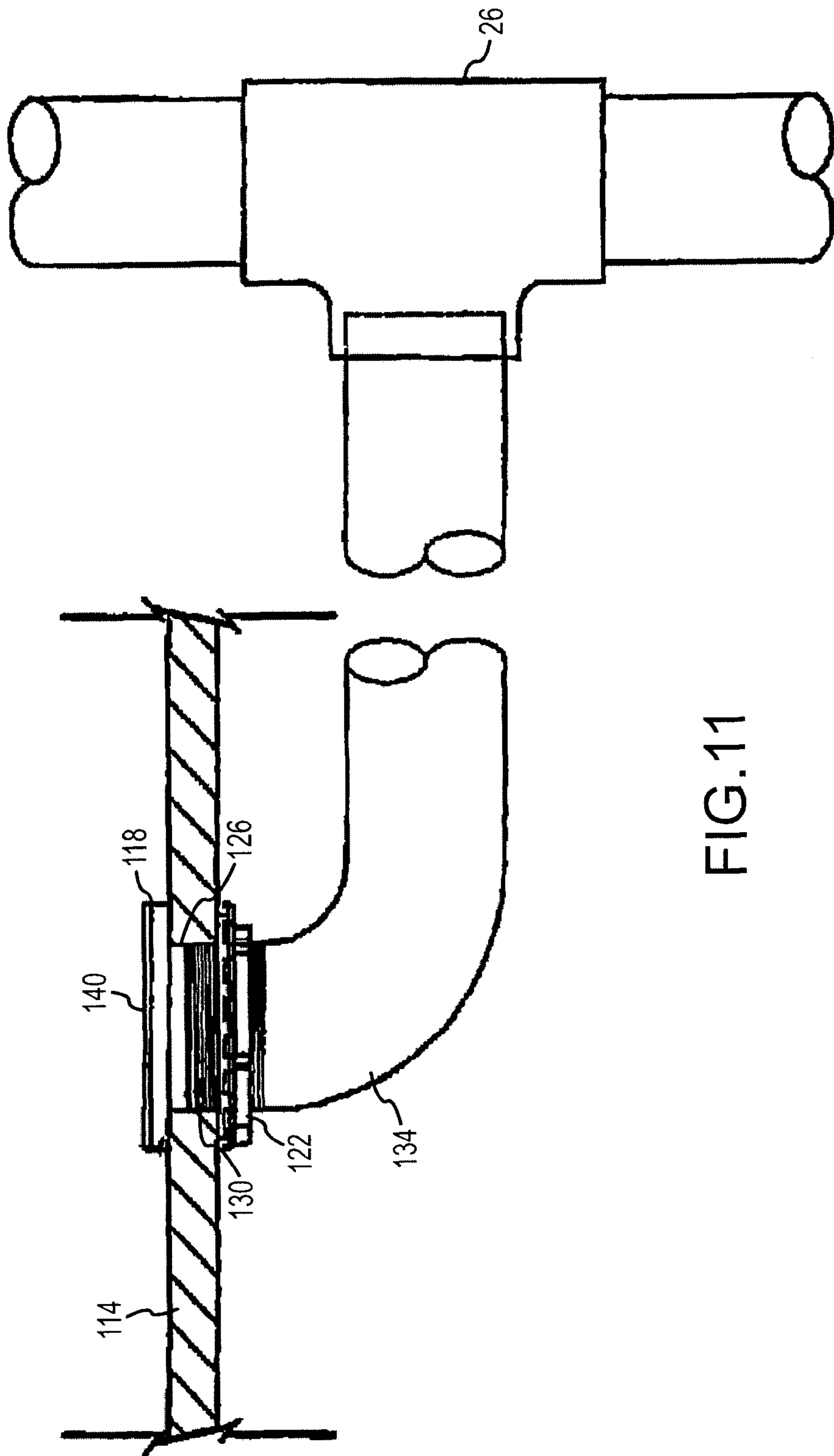

FIG.11

12/23

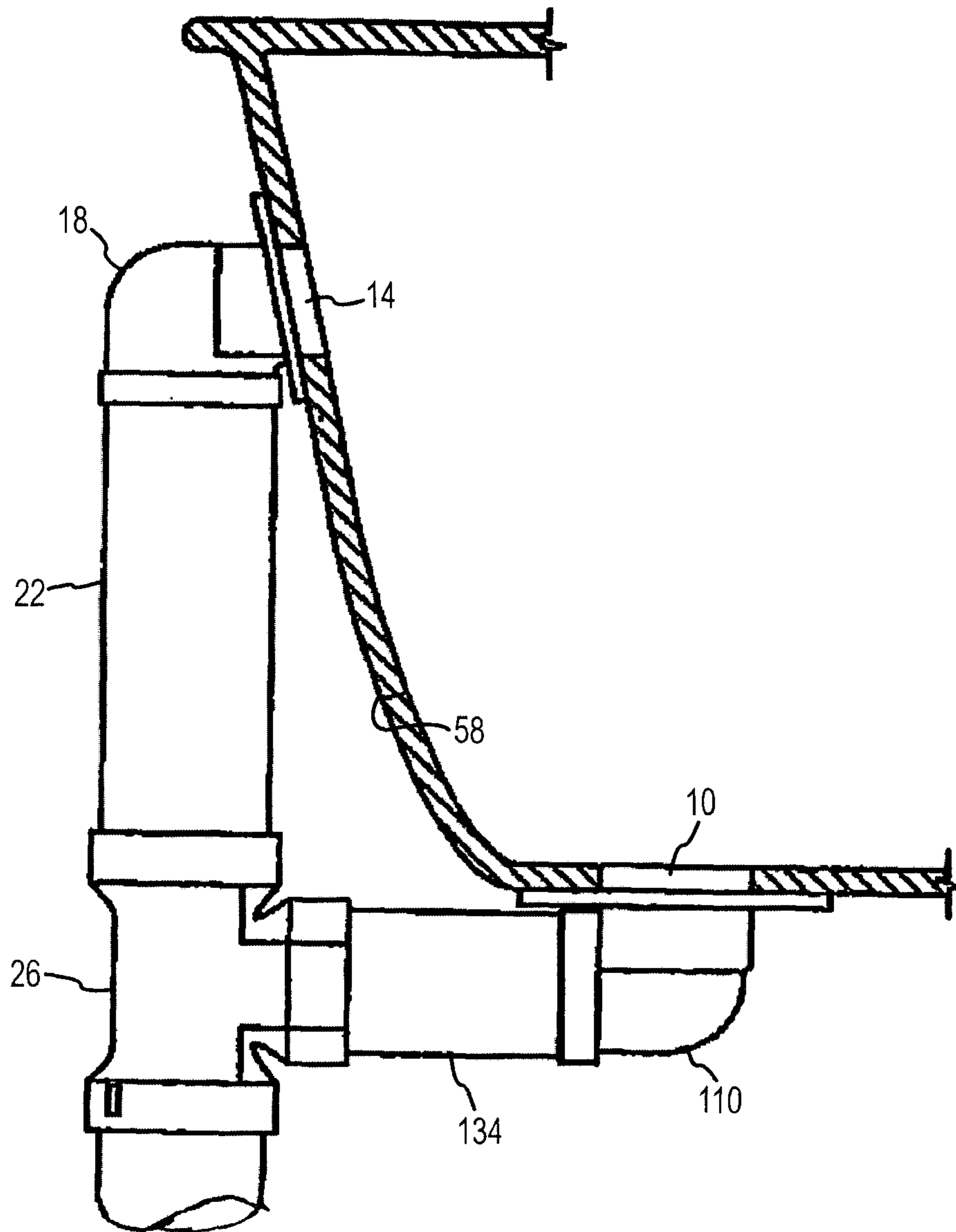

FIG.12  
(PRIOR ART)

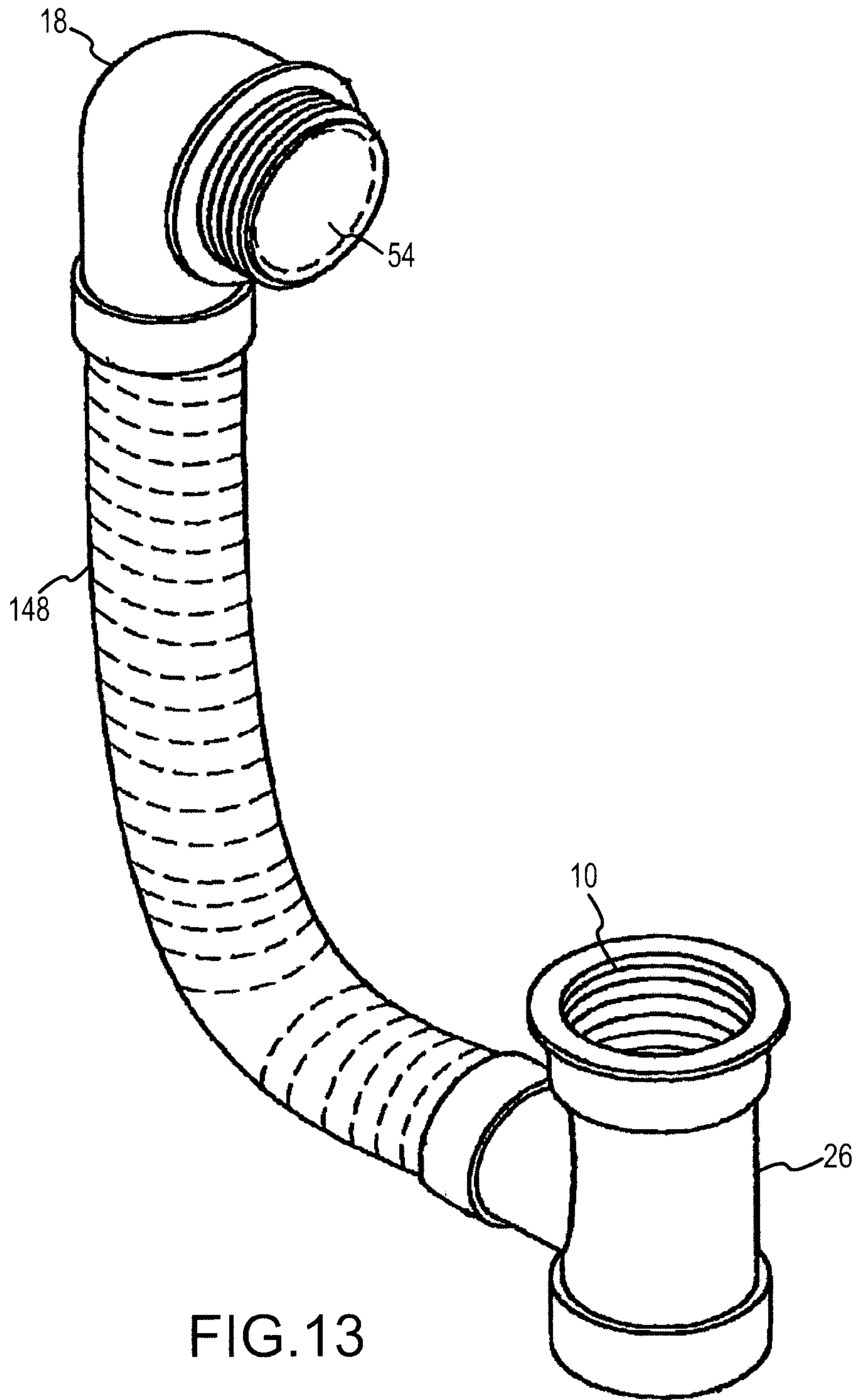

FIG. 13

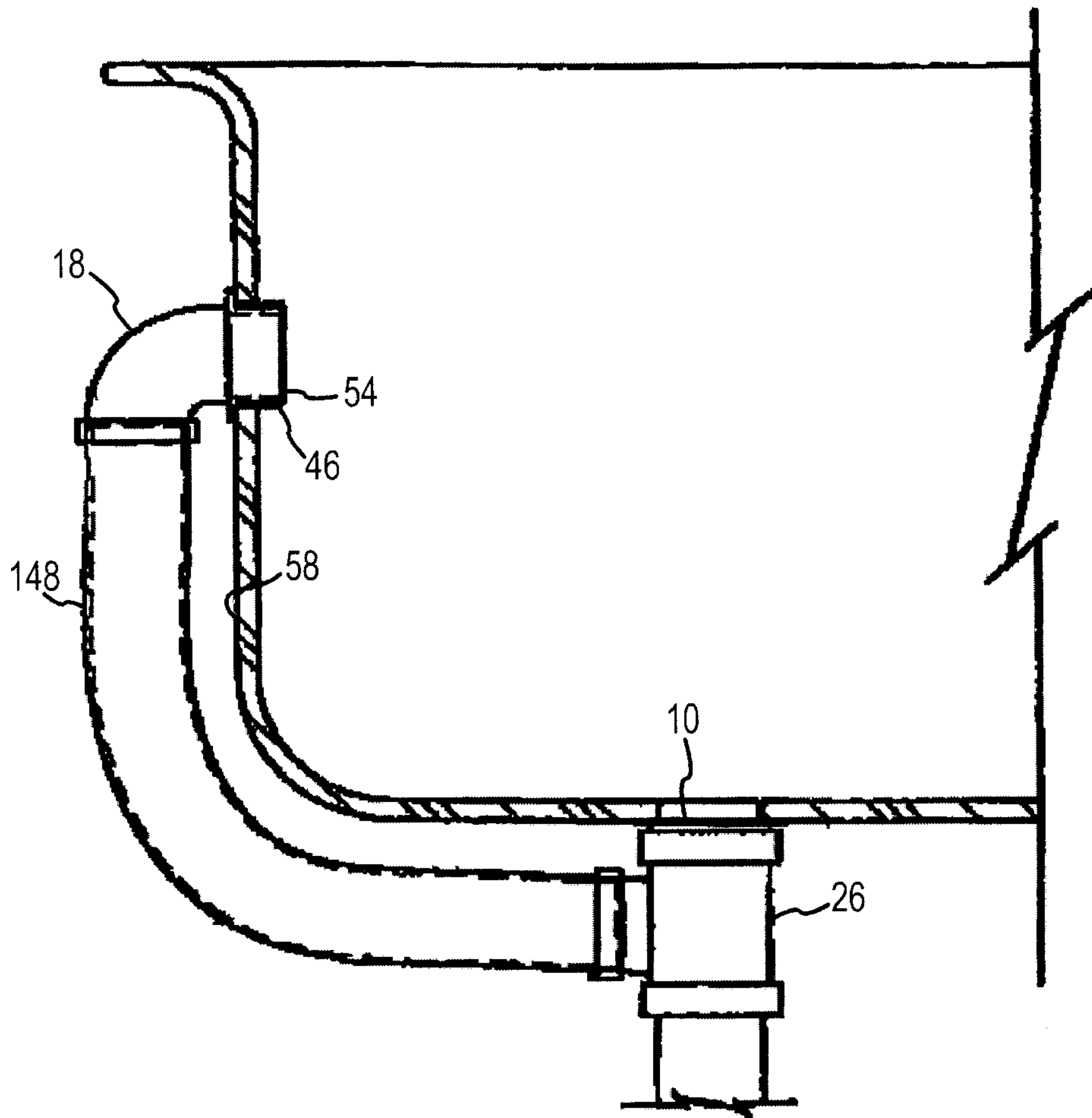

FIG.14

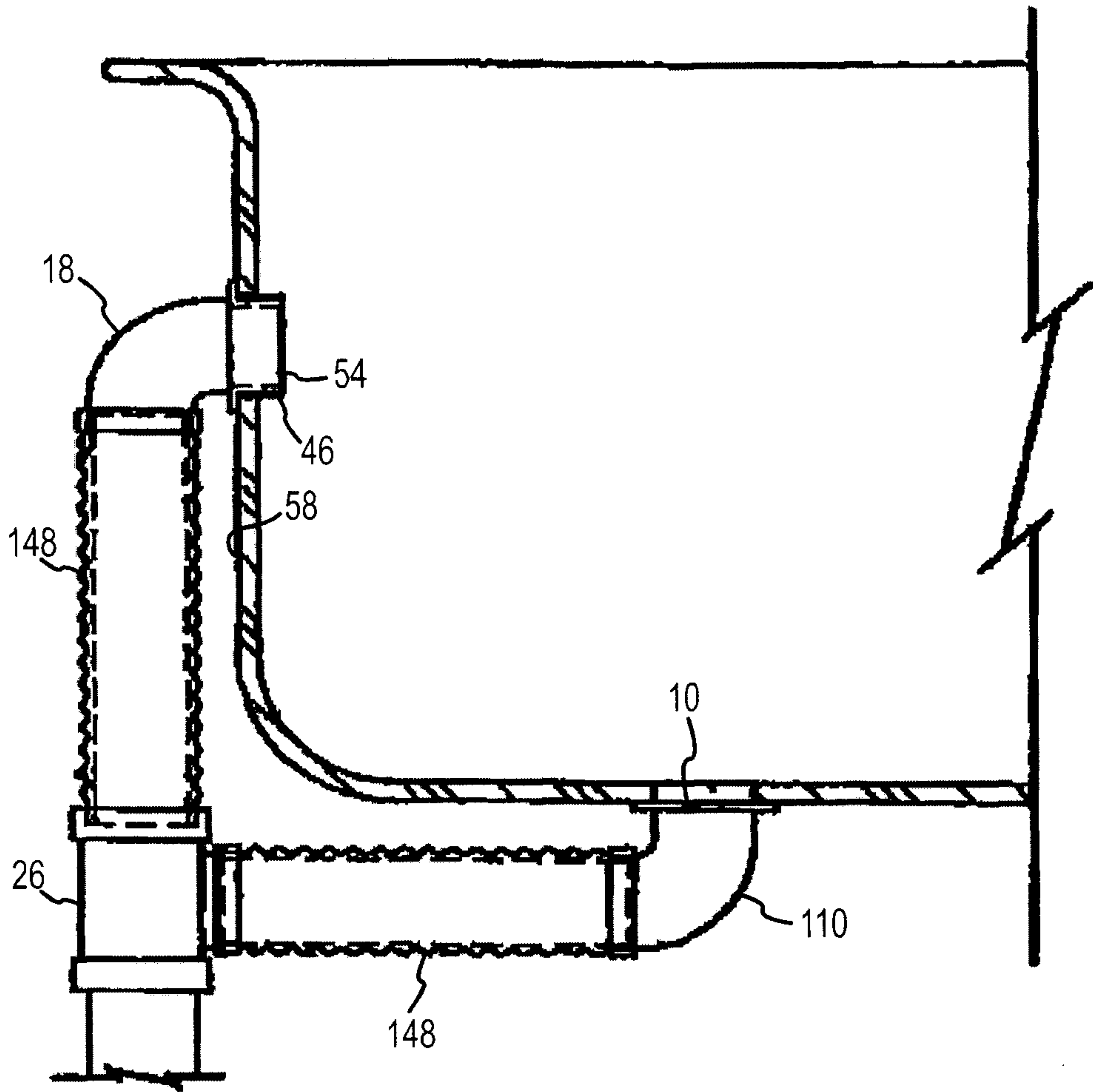

FIG.15

16/23

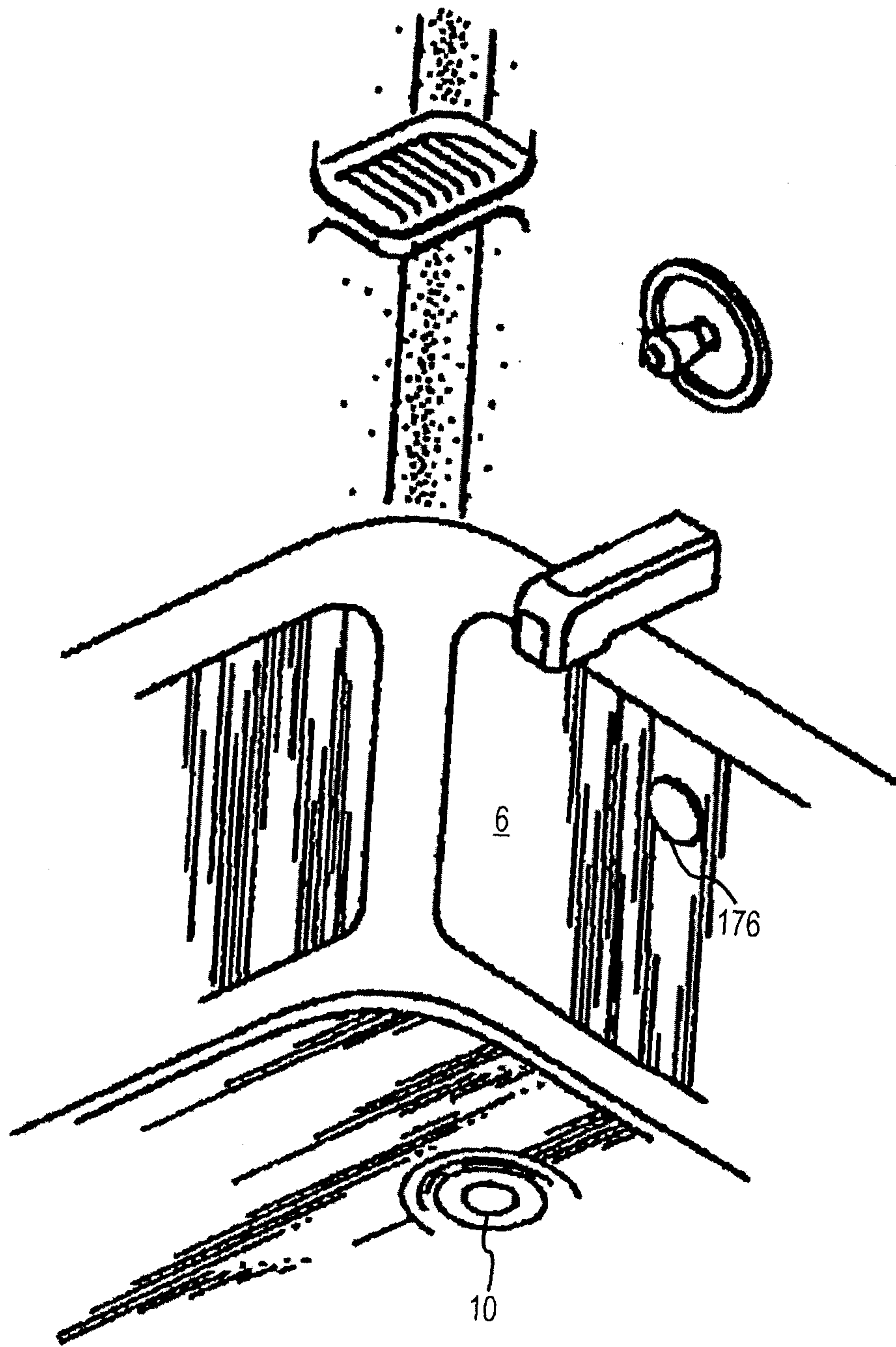
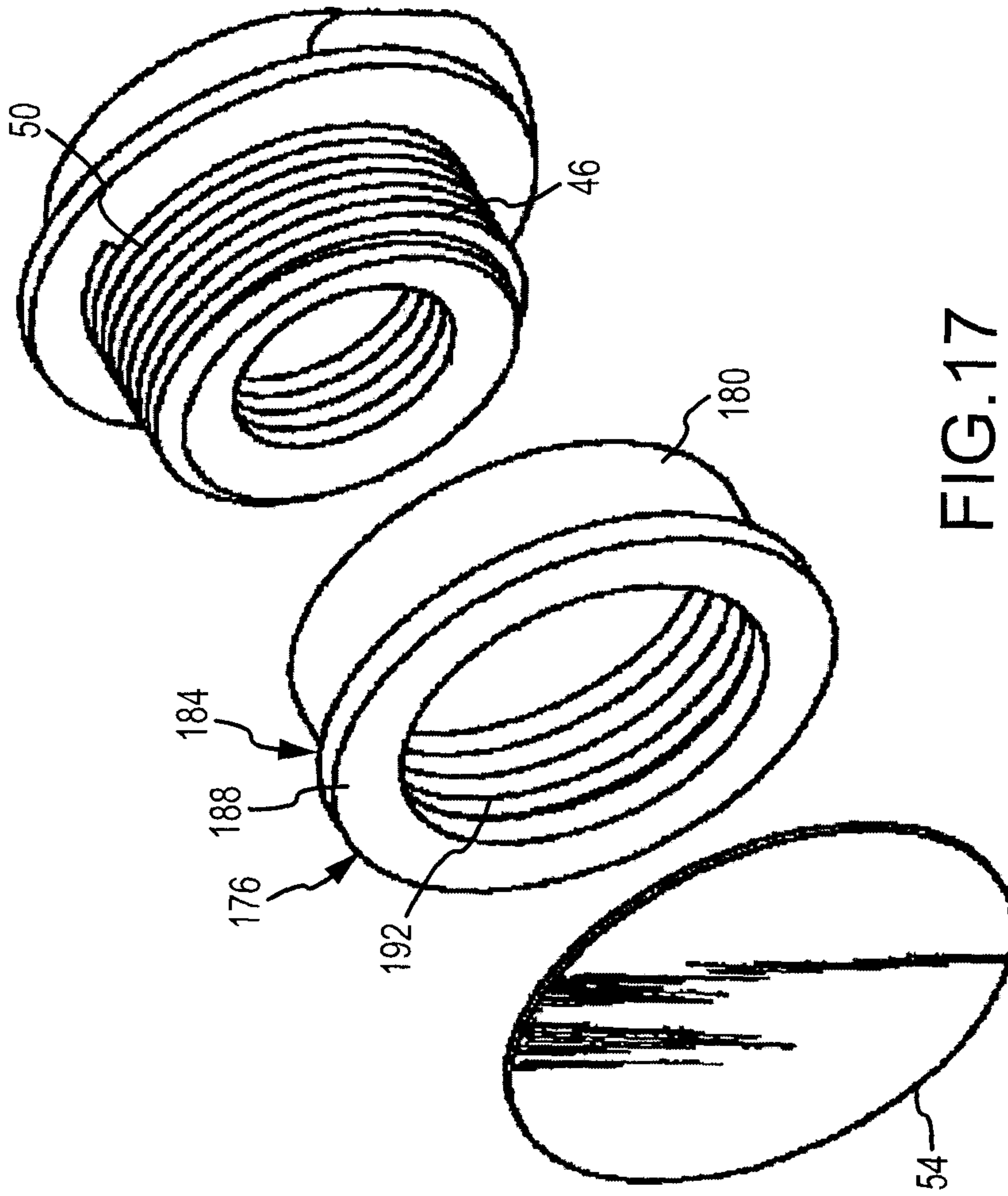

FIG.16



18/23

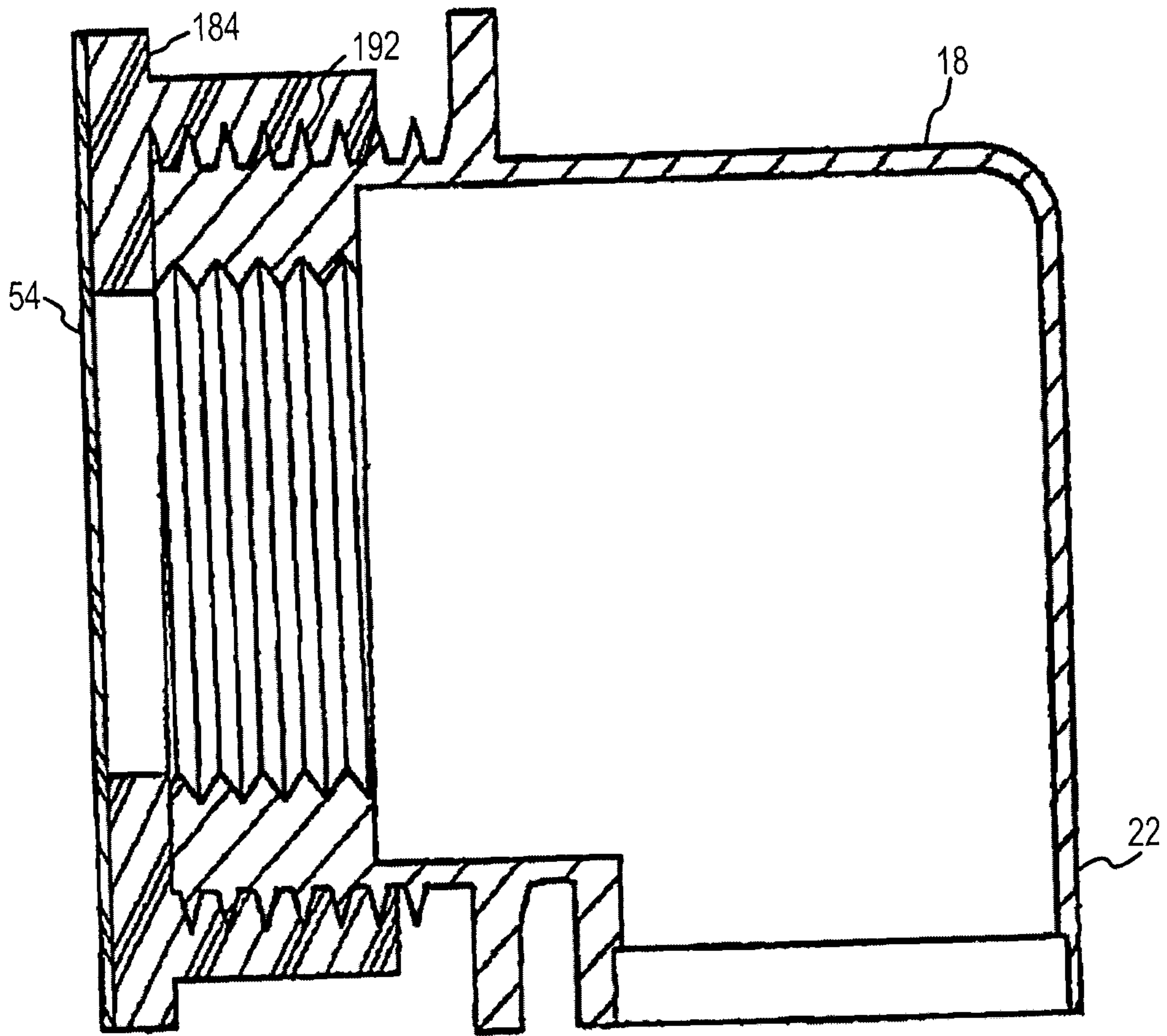

FIG.18

19/23

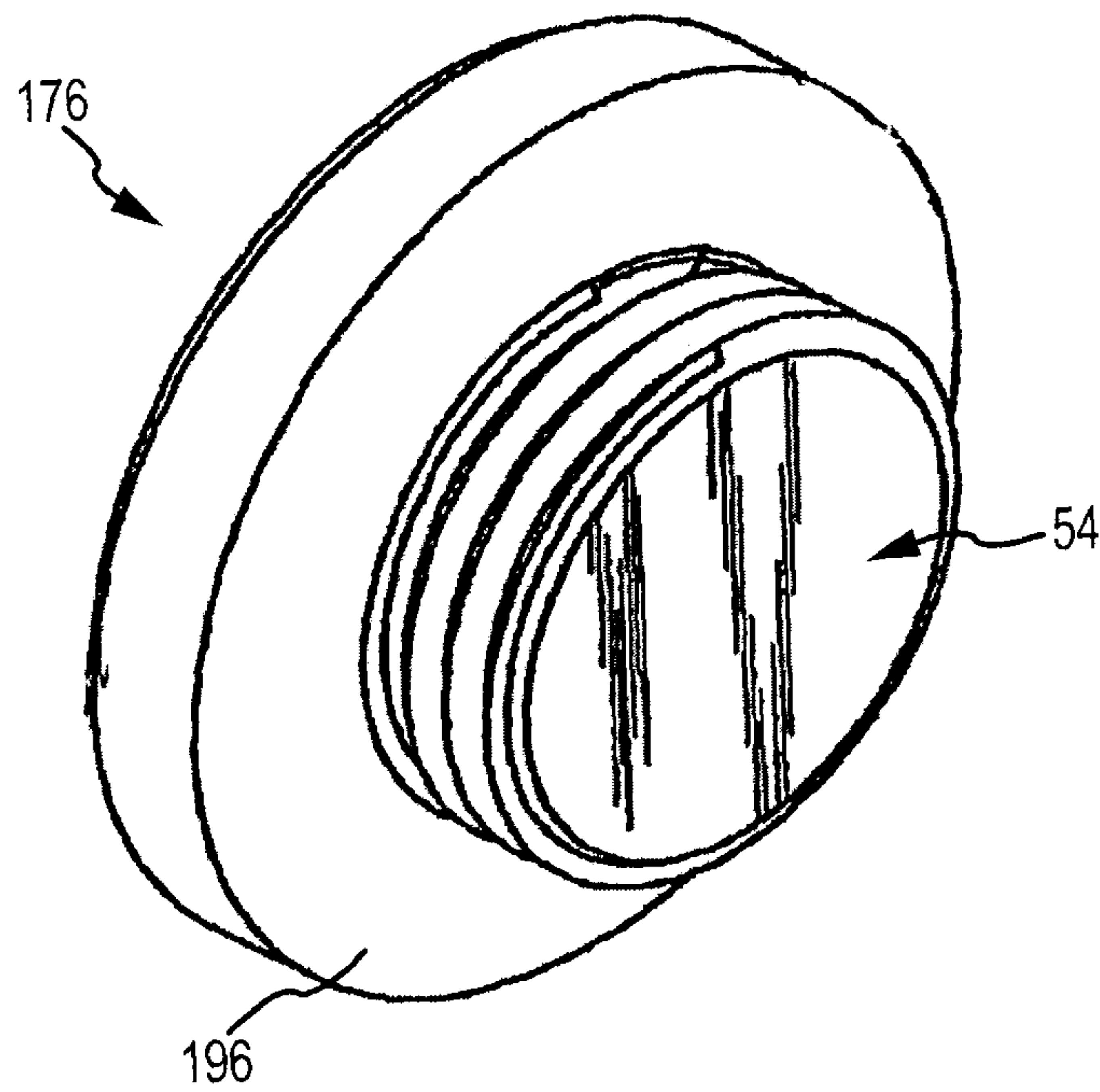

FIG. 19

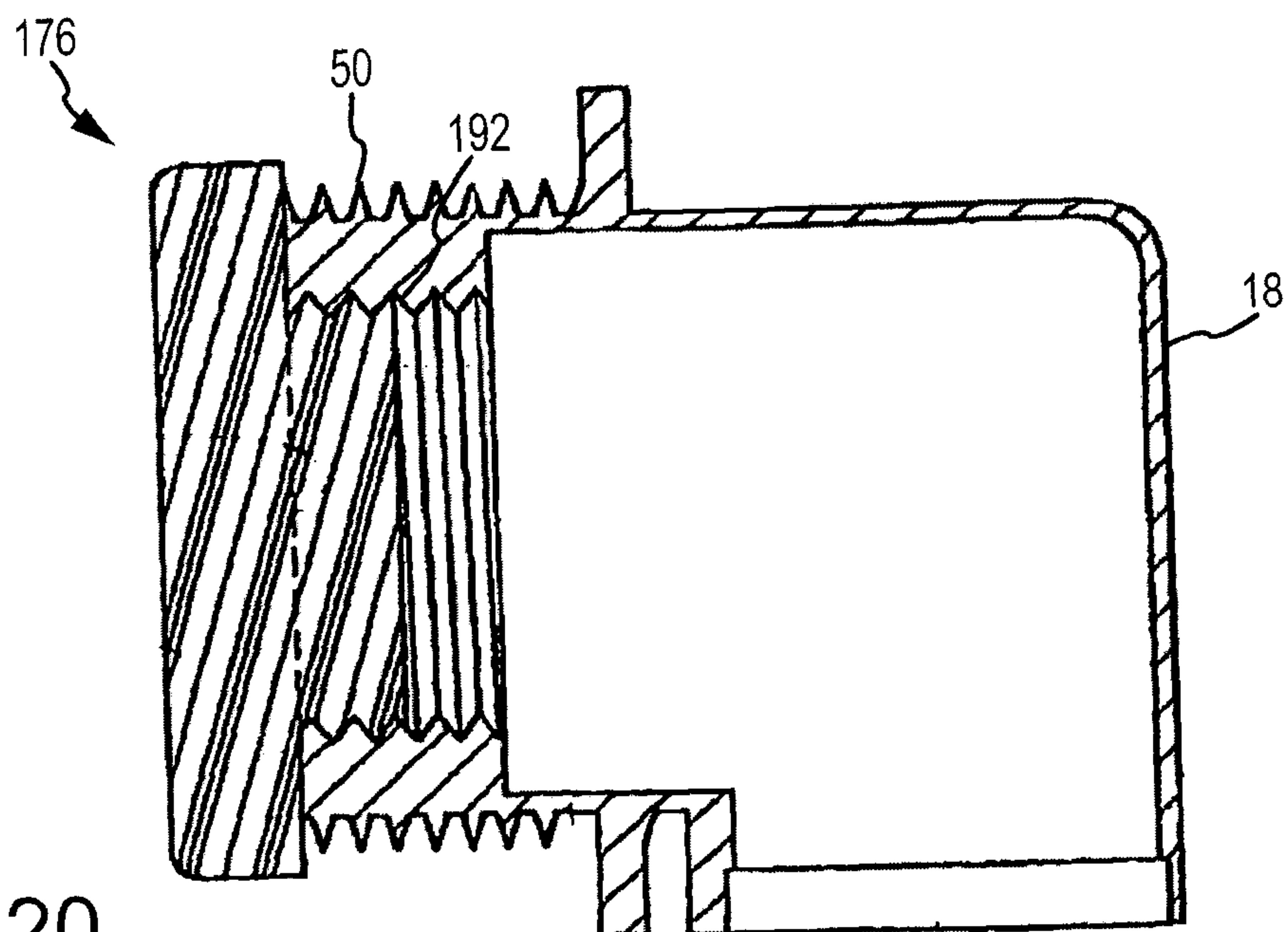

FIG. 20

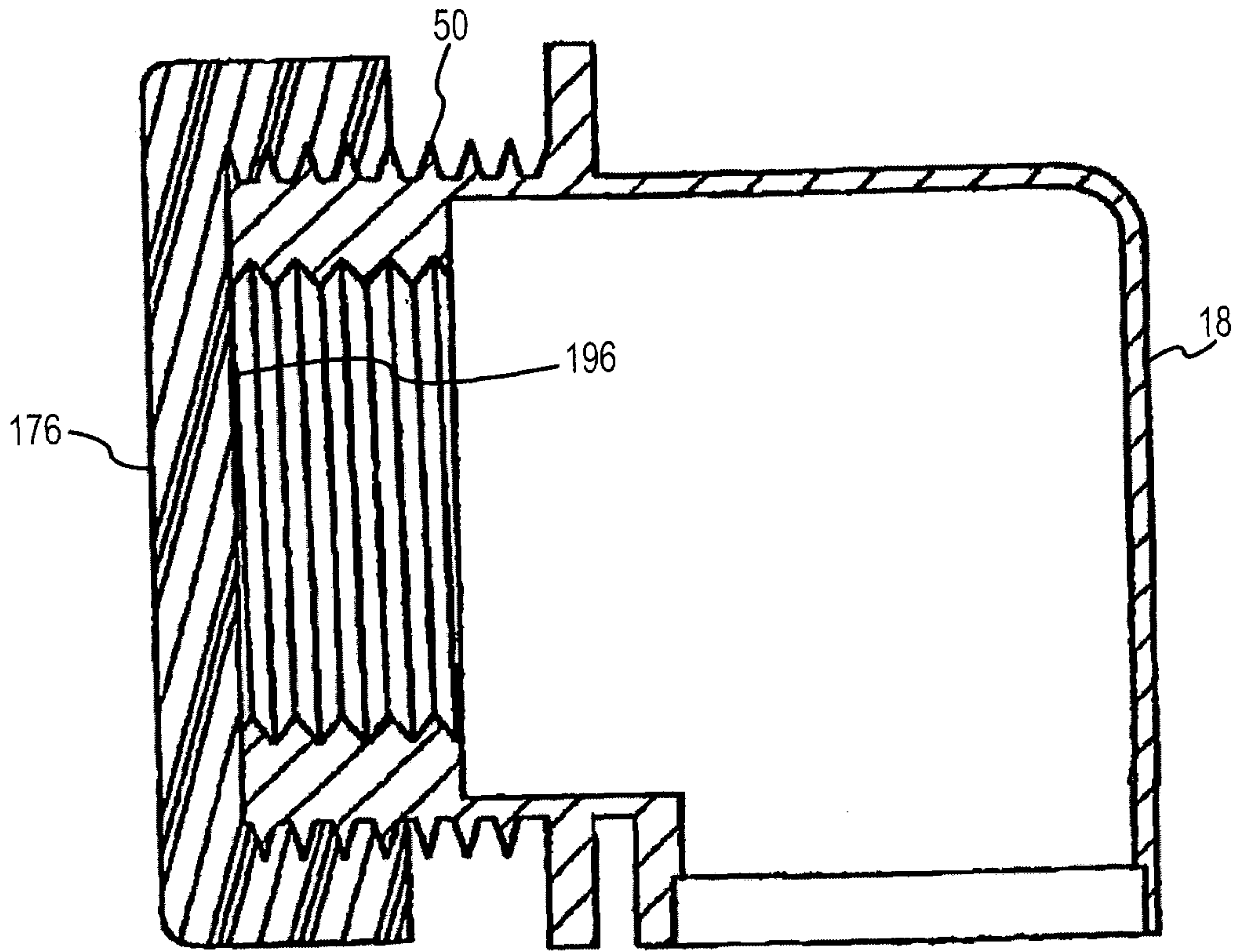

FIG.21

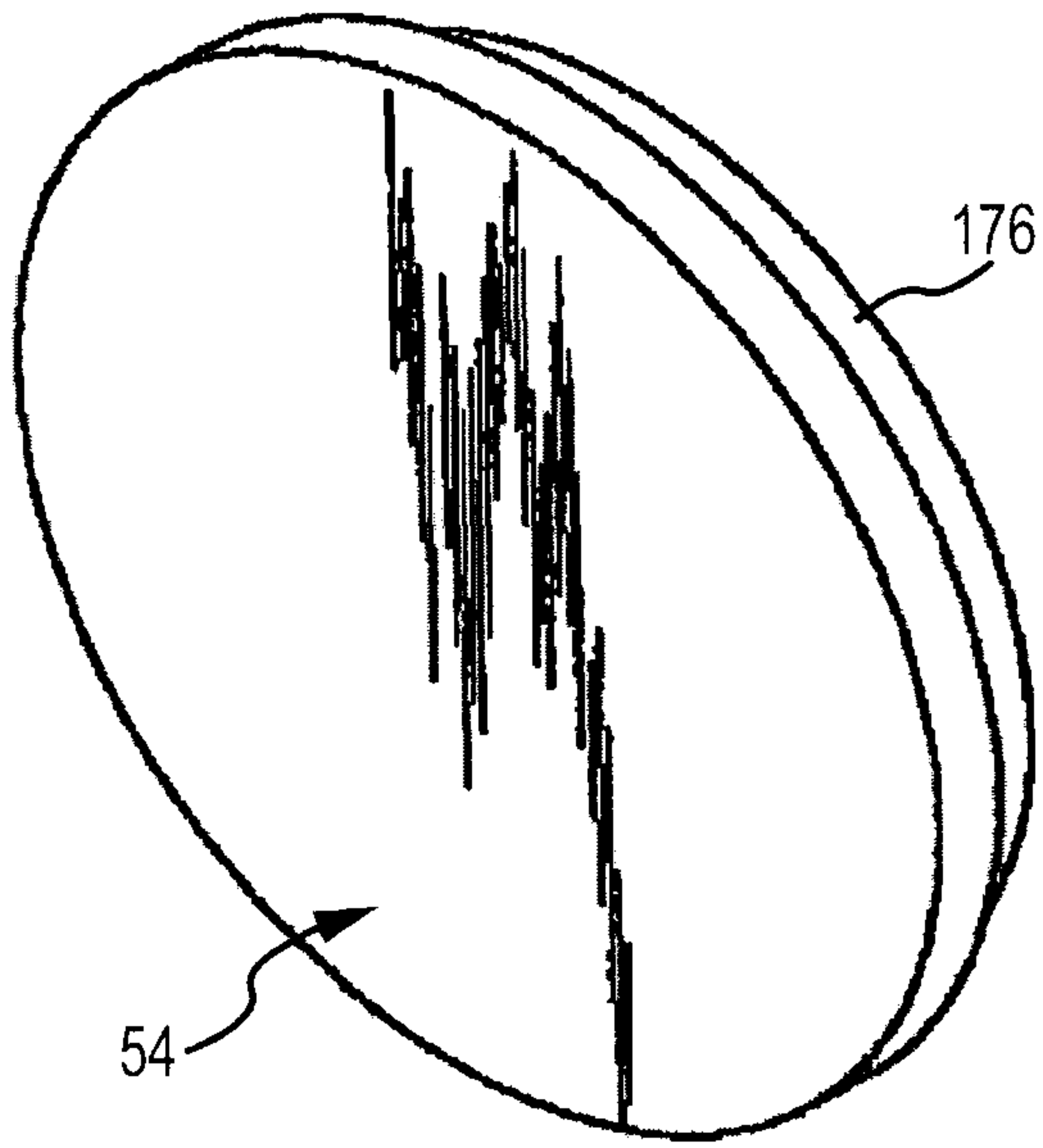

FIG. 22

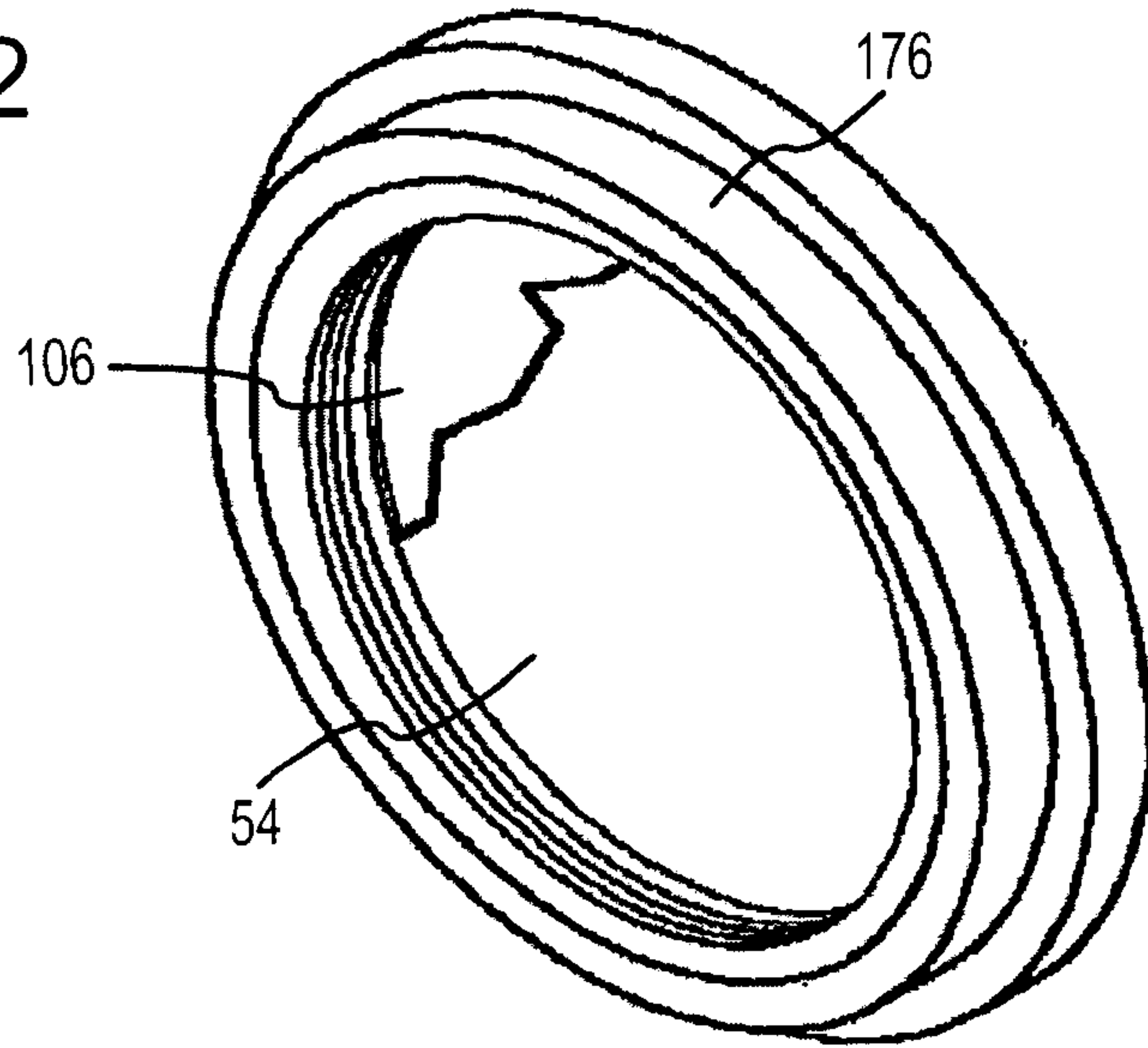

FIG. 23

22/23

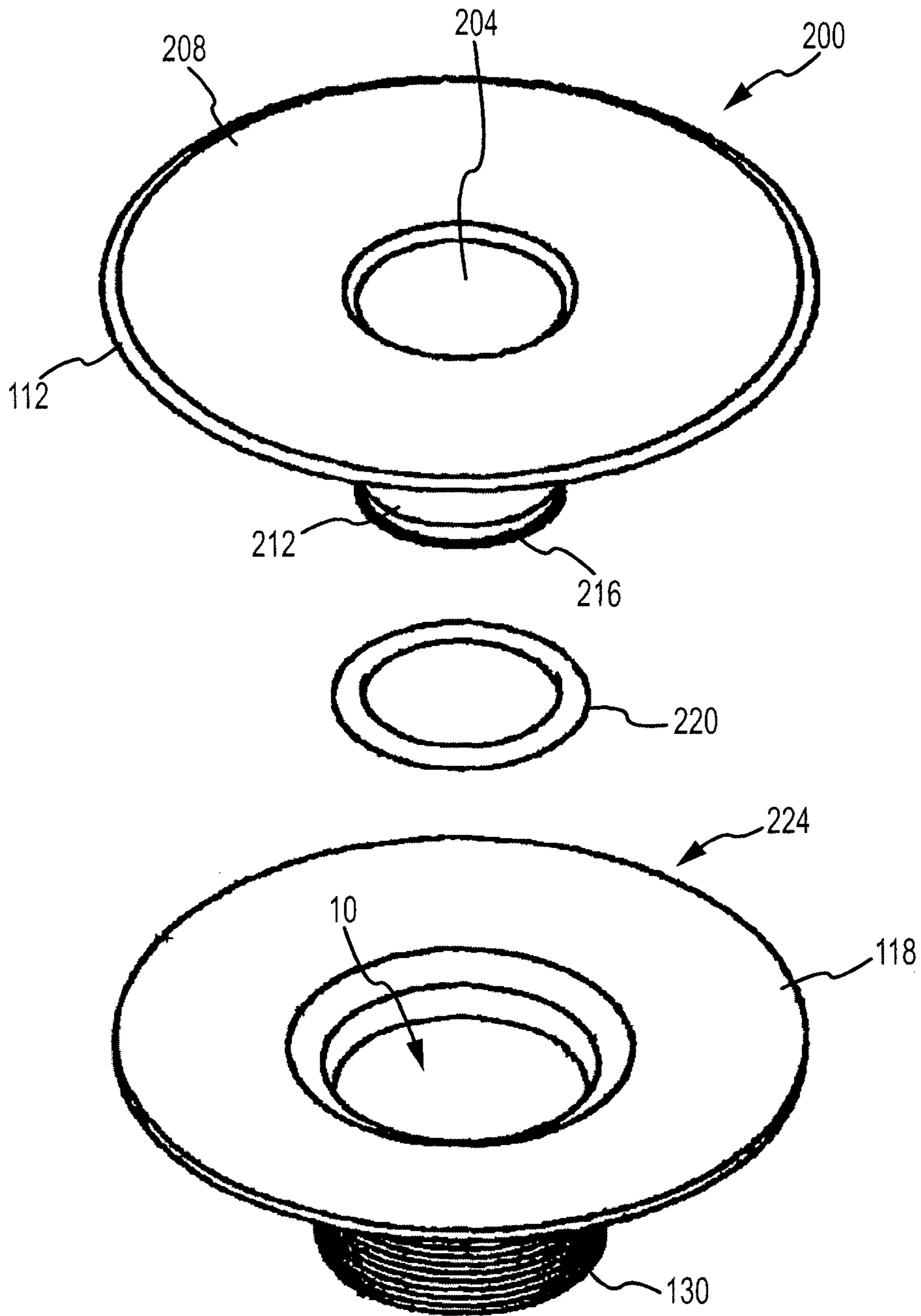

FIG.24

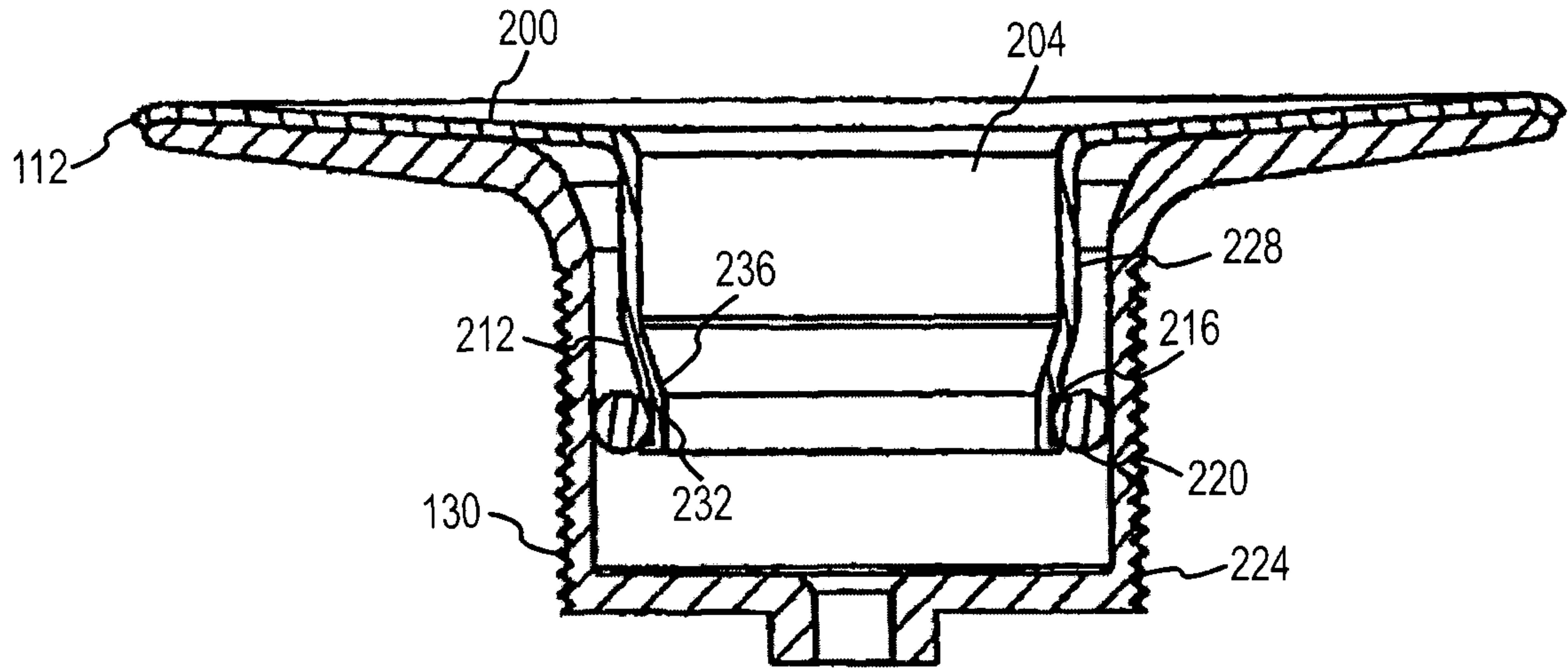

FIG. 25

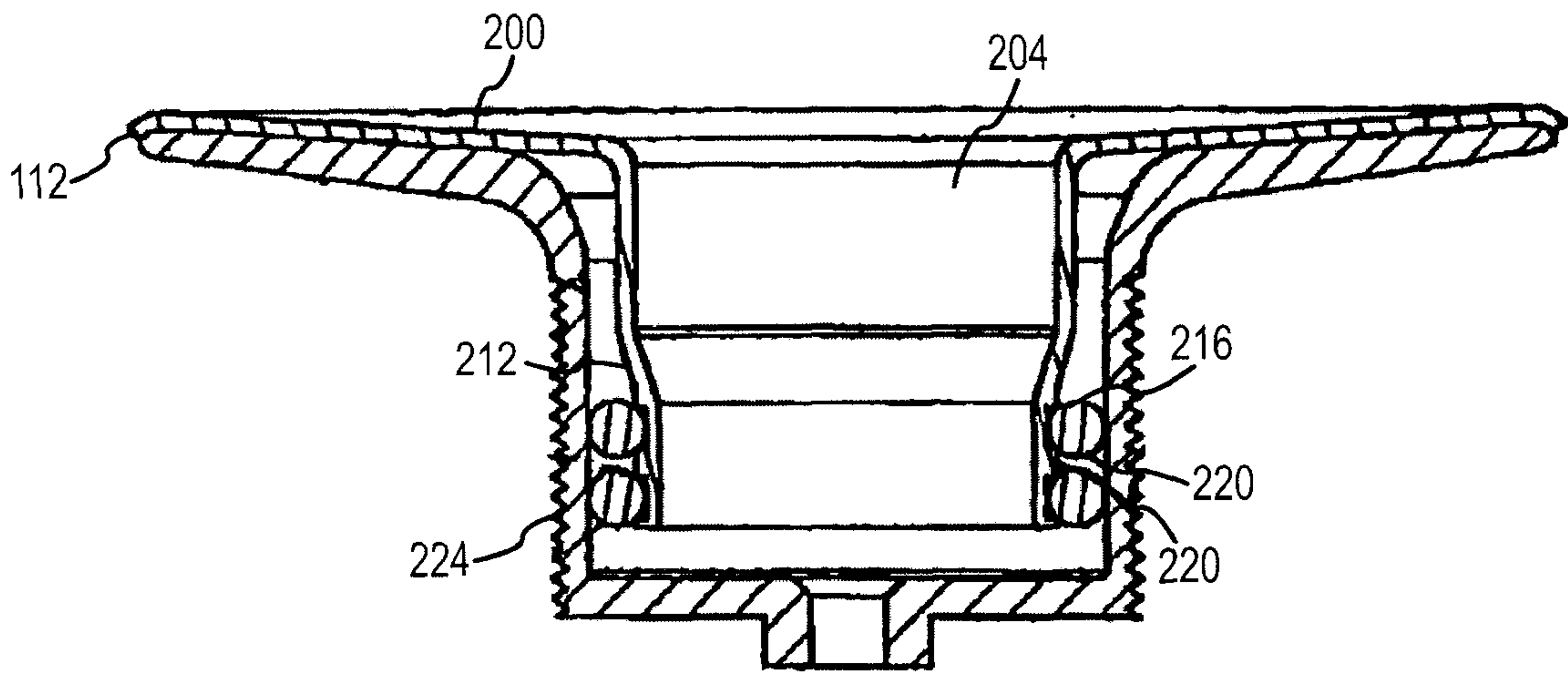

FIG. 26

