



US 20230245961A1

(19) **United States**

(12) **Patent Application Publication**  
**TANIKAWA et al.**

(10) **Pub. No.: US 2023/0245961 A1**

(43) **Pub. Date: Aug. 3, 2023**

(54) **SEMICONDUCTOR MODULE**

**Publication Classification**

(71) Applicant: **ROHM CO., LTD.**, Kyoto-shi, Kyoto (JP)

(51) **Int. Cl.**  
**H01L 23/495** (2006.01)  
**H01L 23/00** (2006.01)  
**H01L 23/31** (2006.01)

(72) Inventors: **Kohei TANIKAWA**, Kyoto-shi, Kyoto (JP); **Kenji HAYASHI**, Kyoto-shi, Kyoto (JP); **Ryosuke FUKUDA**, Kyoto-shi, Kyoto (JP)

(52) **U.S. Cl.**  
CPC ..... **H01L 23/49575** (2013.01); **H01L 24/18** (2013.01); **H01L 24/48** (2013.01); **H01L 23/3121** (2013.01); **H01L 2224/48247** (2013.01); **H01L 2924/182** (2013.01)

(21) Appl. No.: **18/011,798**

(57) **ABSTRACT**

(22) PCT Filed: **Sep. 14, 2021**

A semiconductor module includes a conductive substrate, a semiconductor element, a control terminal, and a sealing resin. The conductive substrate has an obverse surface and a reverse surface that are spaced apart from each other in a thickness direction. The semiconductor element is electrically bonded to the obverse surface and has a switching function. The control terminal is configured to control the semiconductor element. The sealing resin has a resin obverse surface and a resin reverse surface, and covers the conductive substrate, the semiconductor element, and a part of the control terminal. The control terminal protrudes from the resin obverse surface, and extends along the thickness direction.

(86) PCT No.: **PCT/JP2021/033676**

§ 371 (c)(1),

(2) Date: **Dec. 20, 2022**

(30) **Foreign Application Priority Data**

Oct. 14, 2020 (JP) ..... 2020-173335

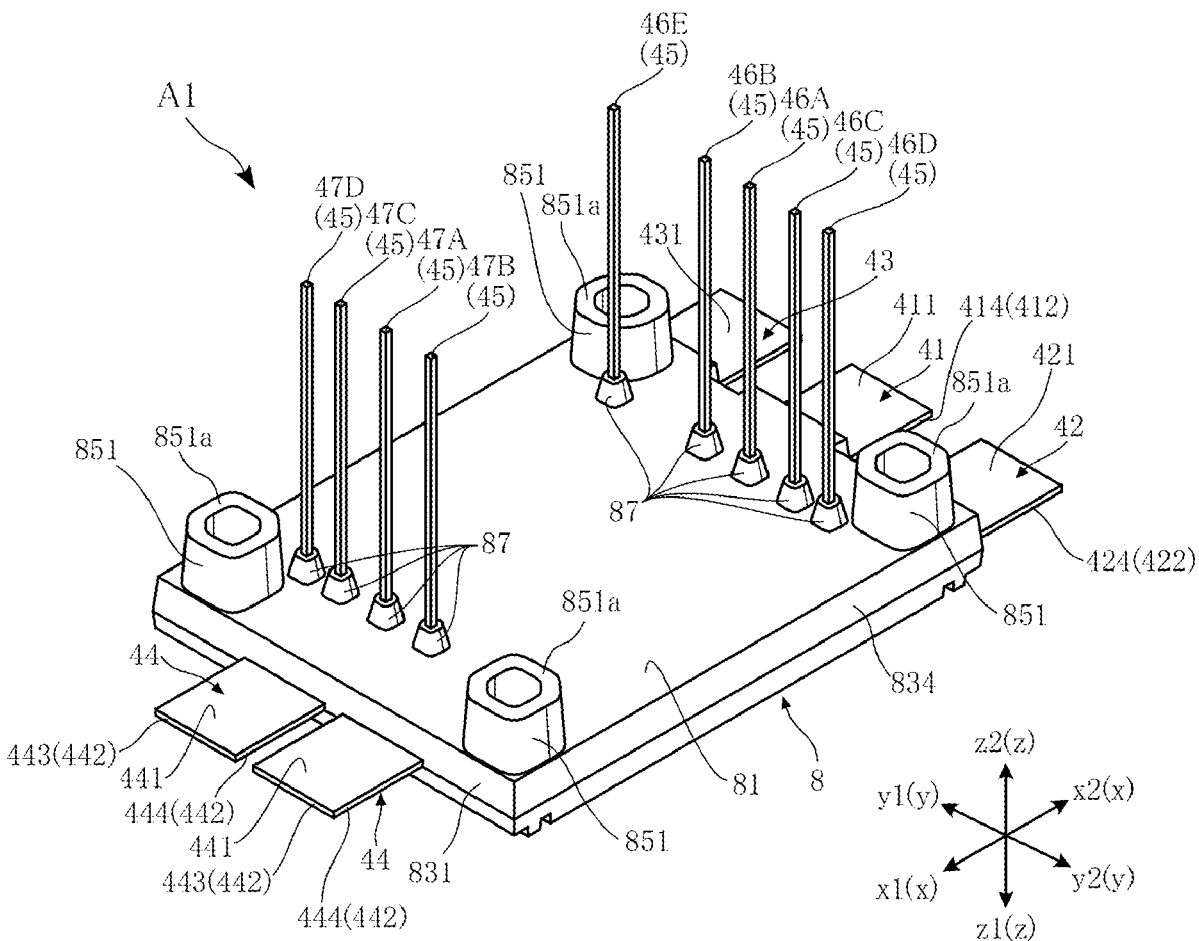

FIG. 1

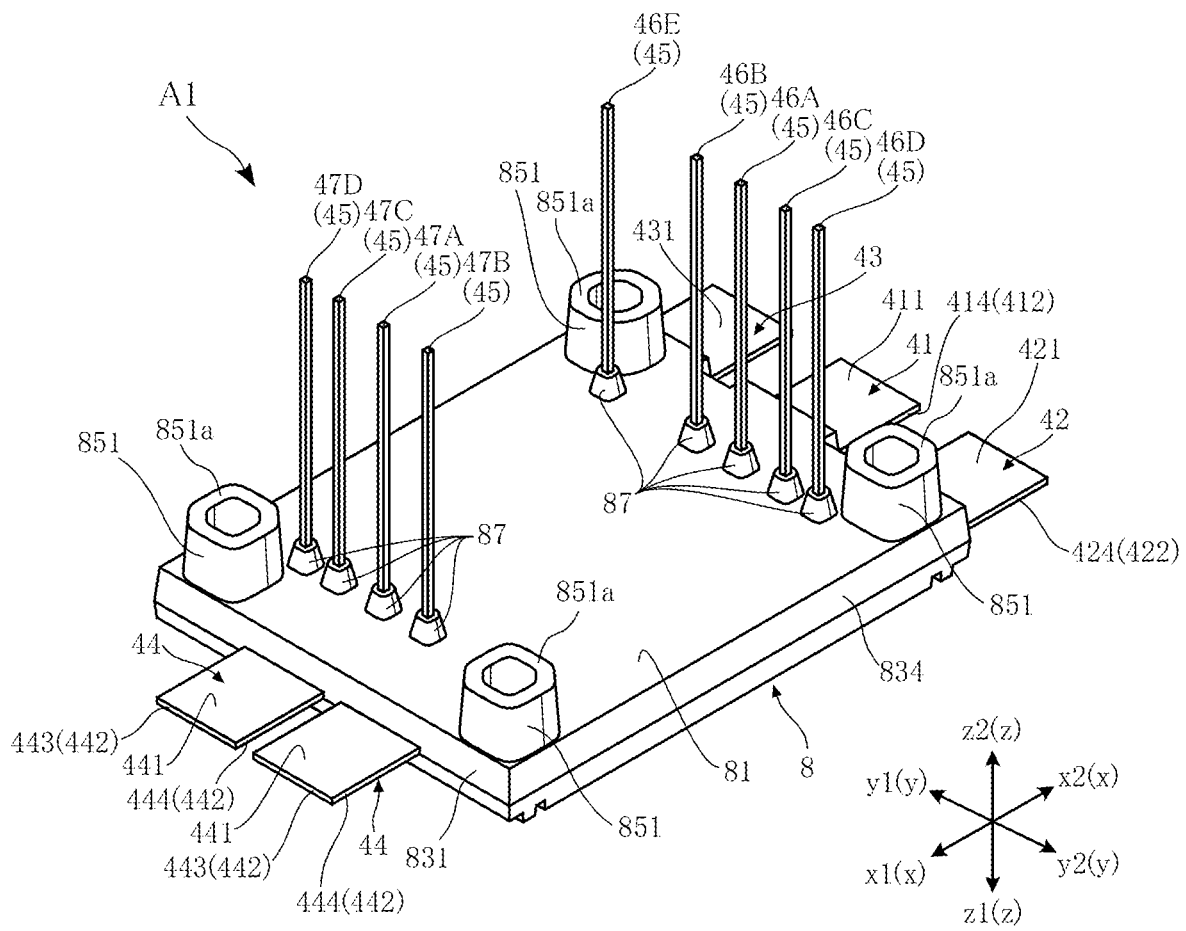

FIG.2

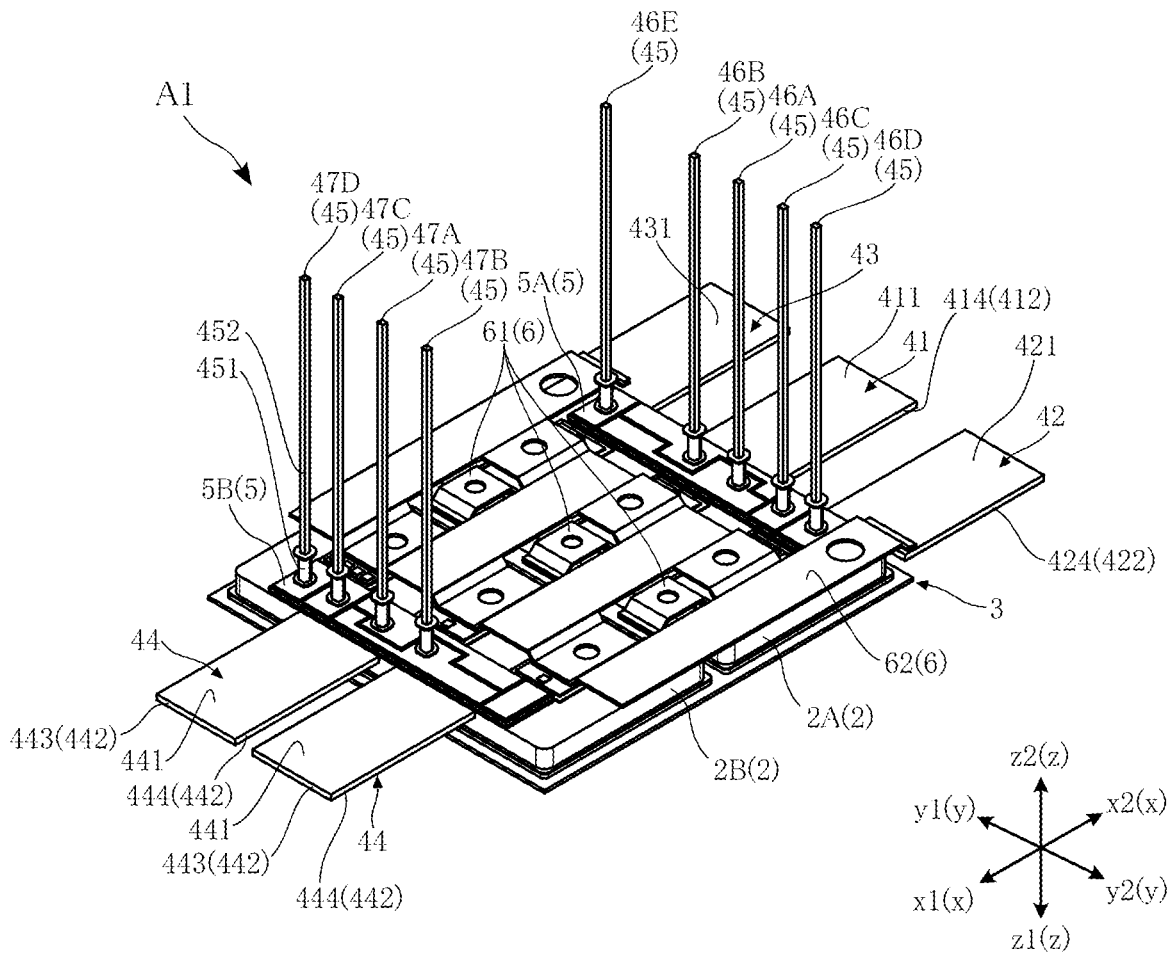
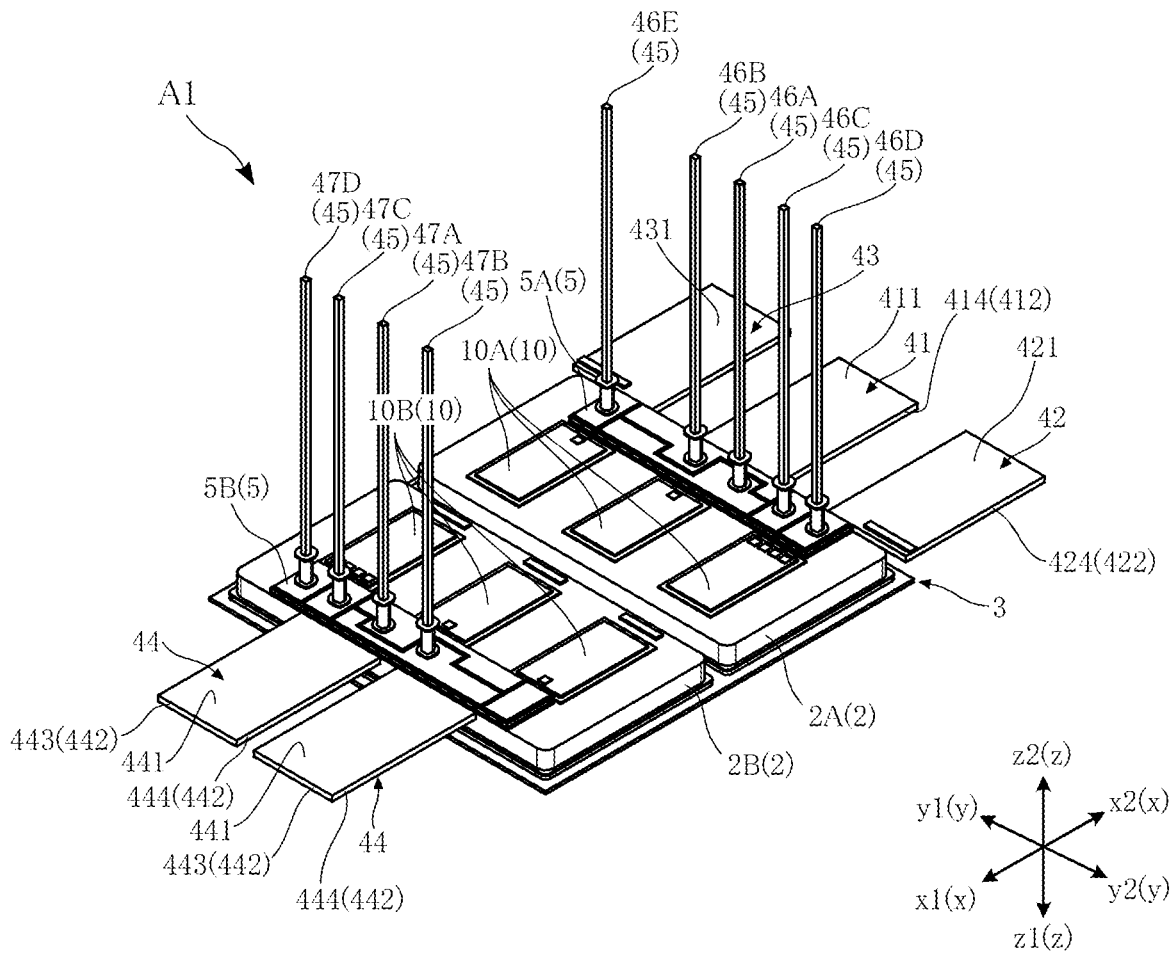
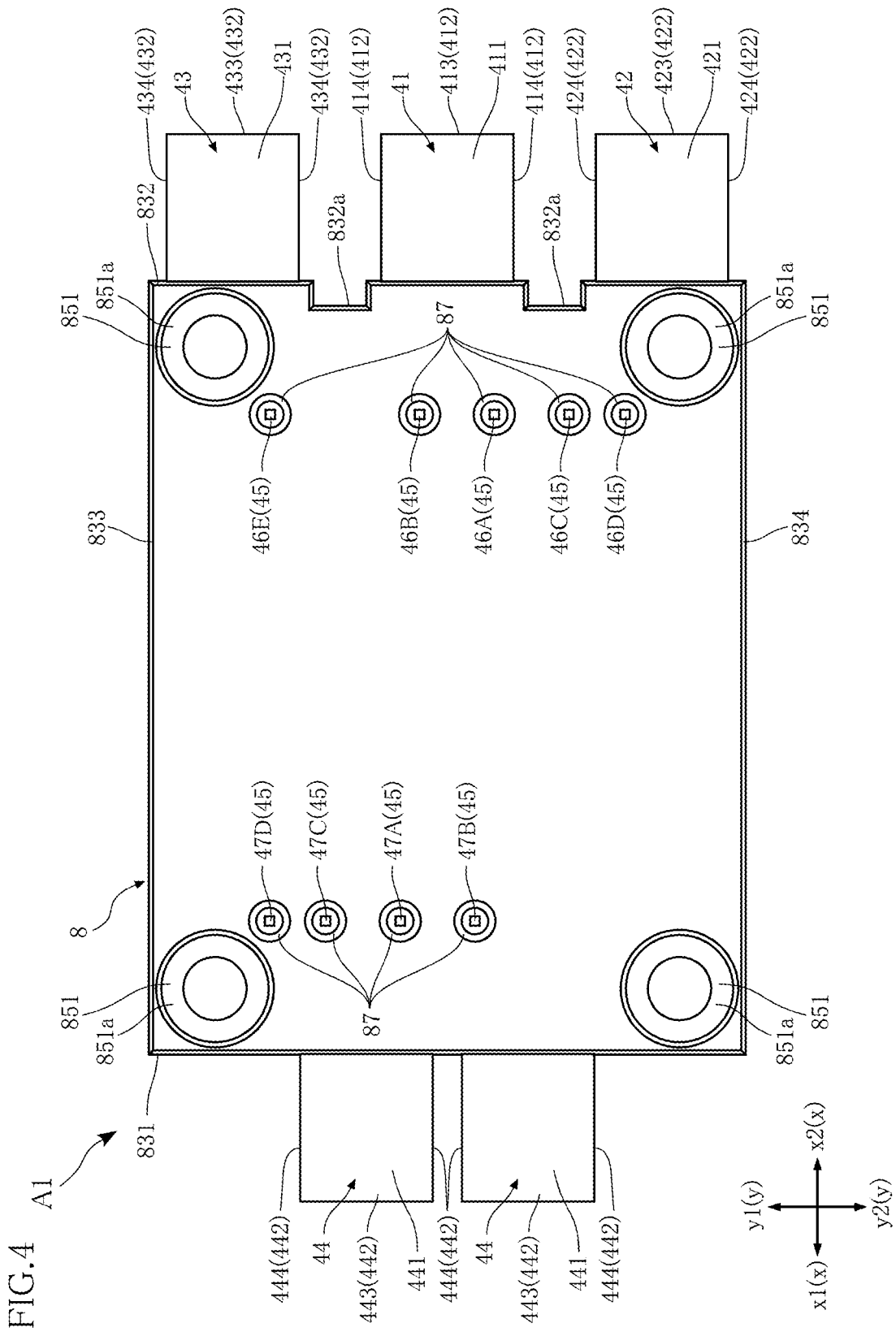
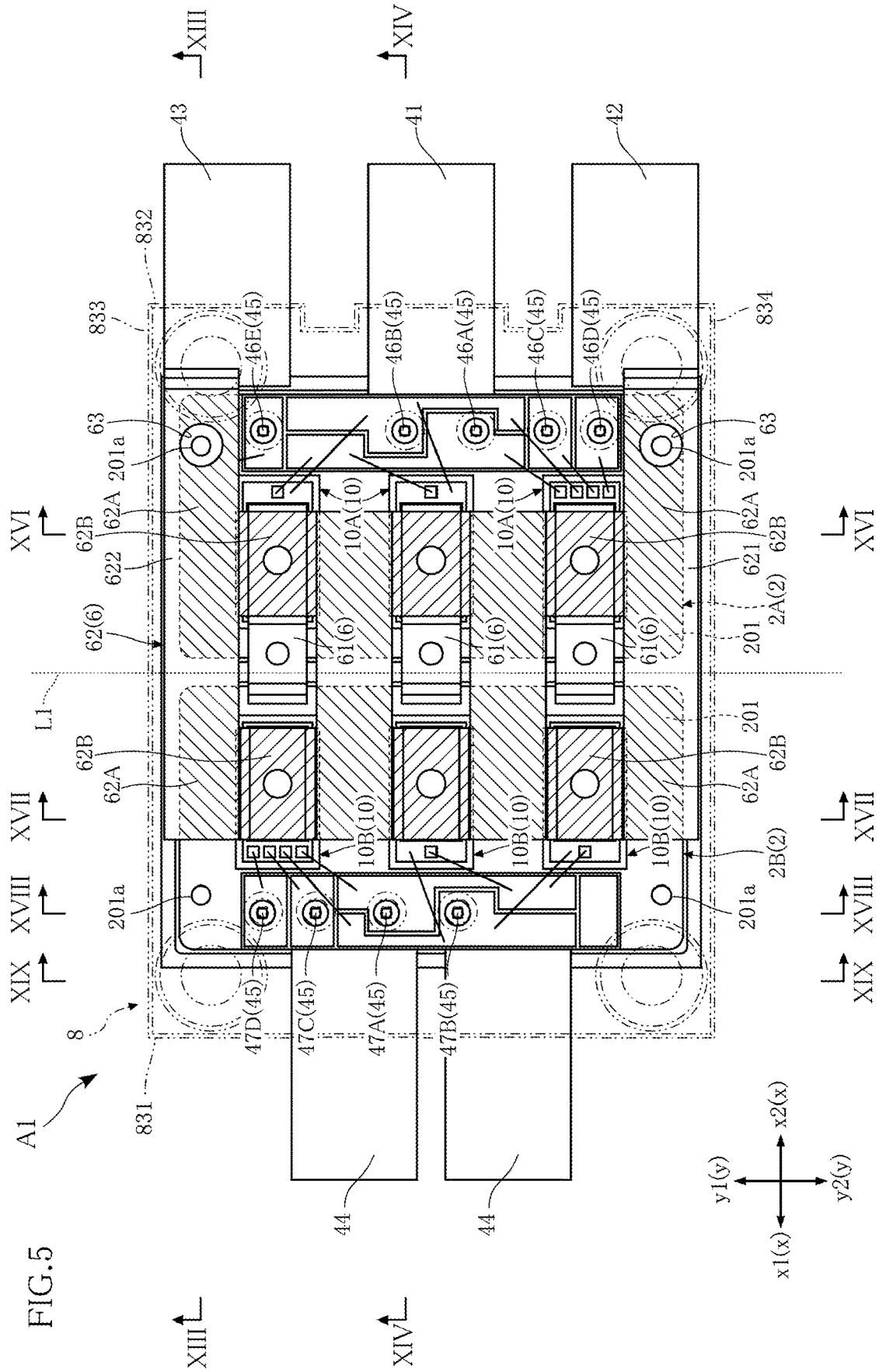

FIG. 3







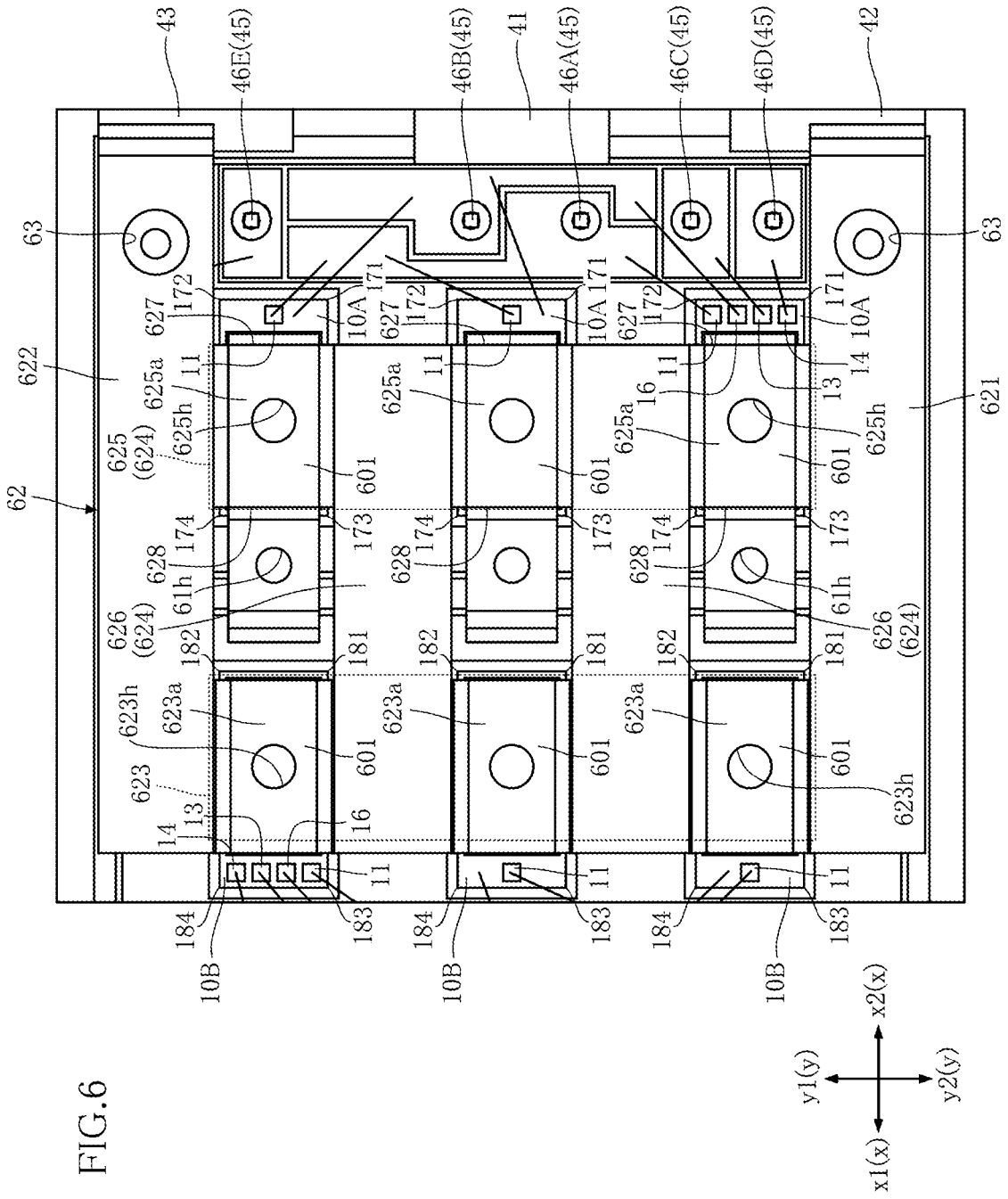

FIG. 7

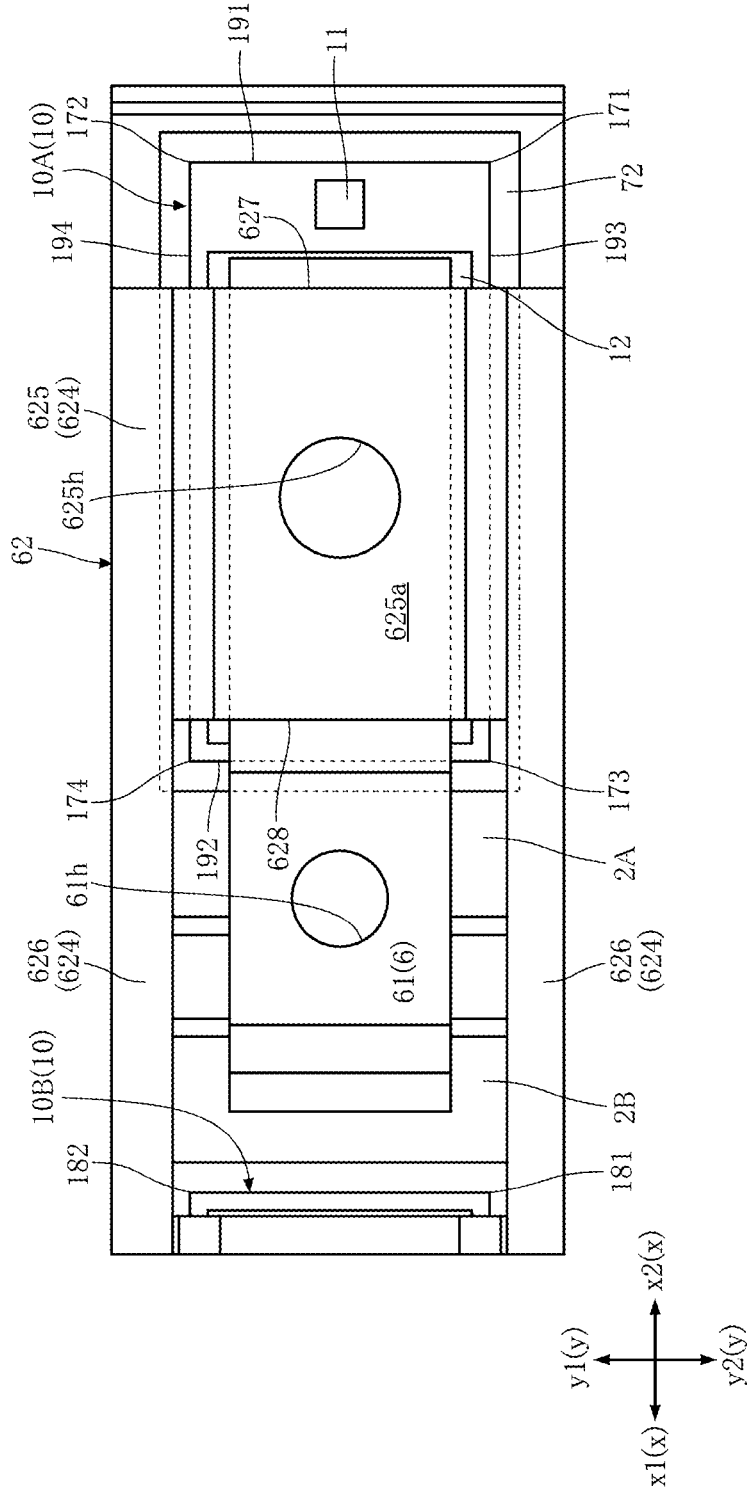
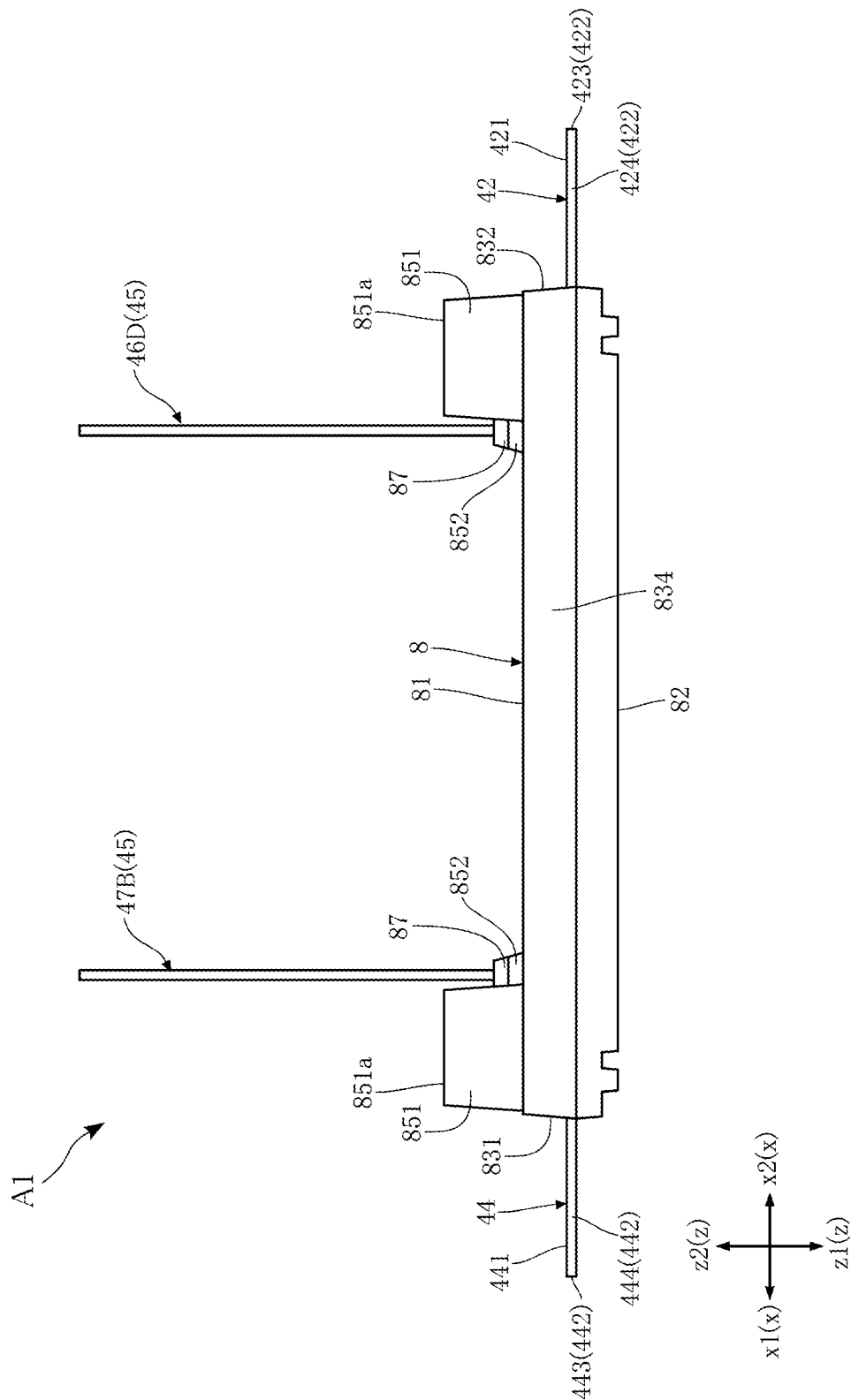



FIG. 9



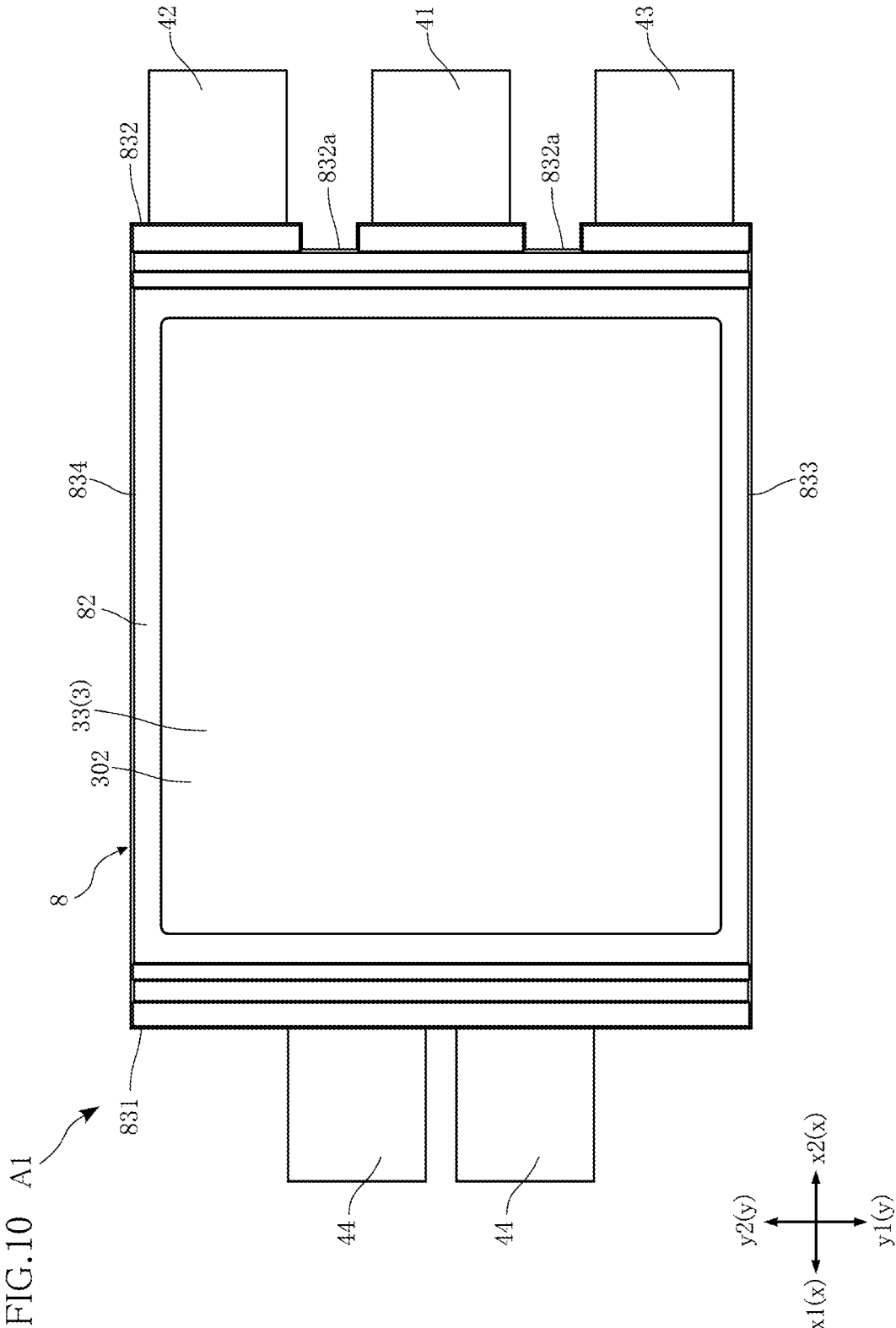

FIG. 11

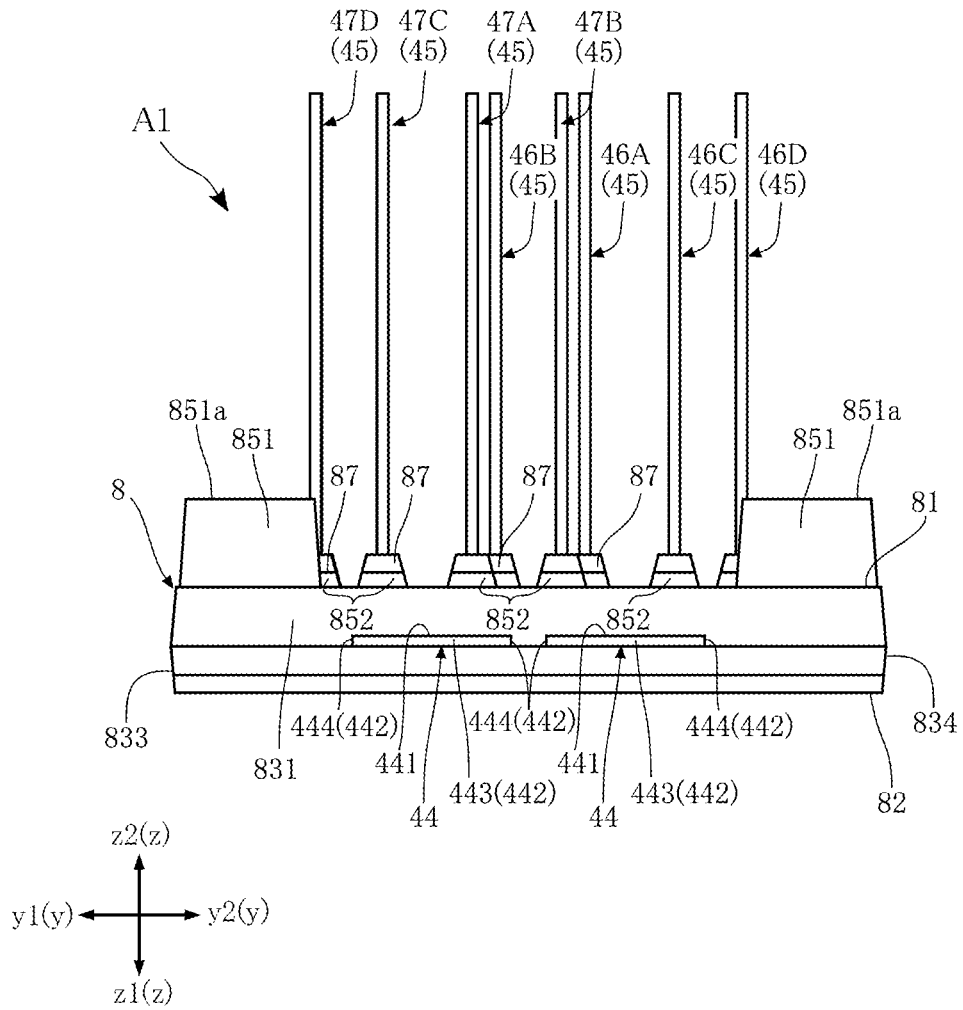

FIG. 12

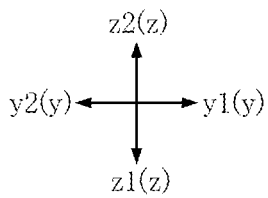
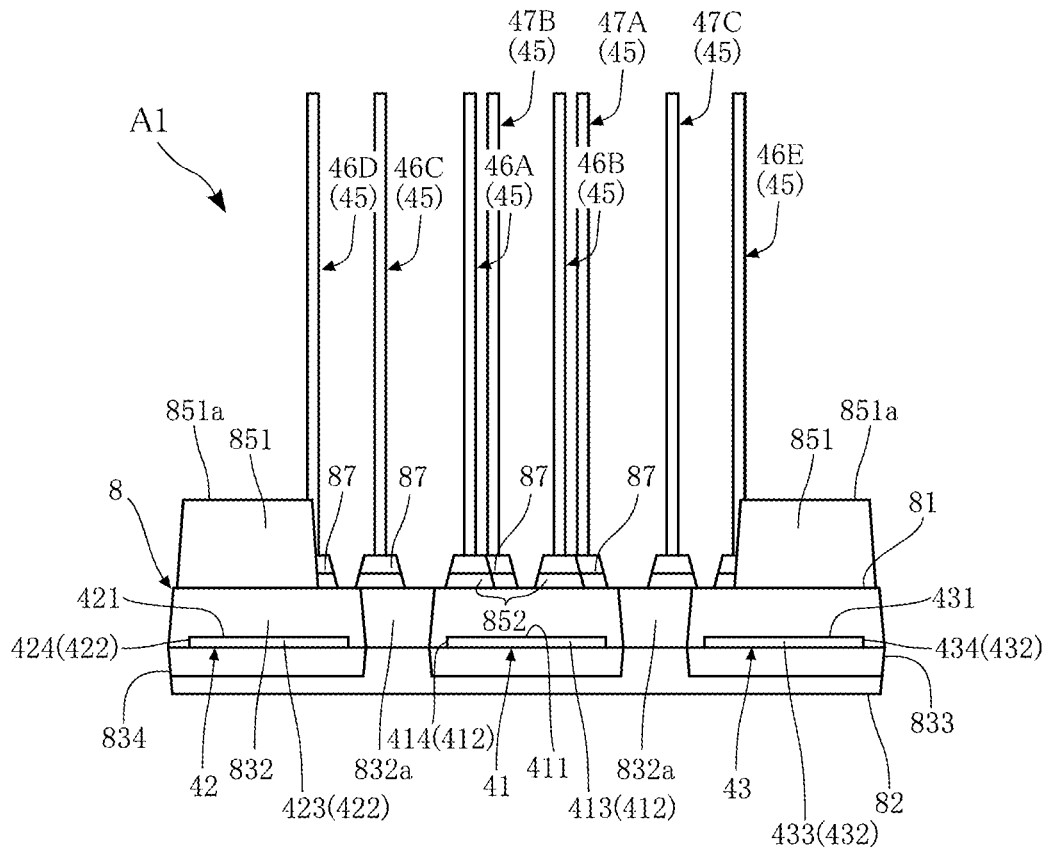

FIG.13

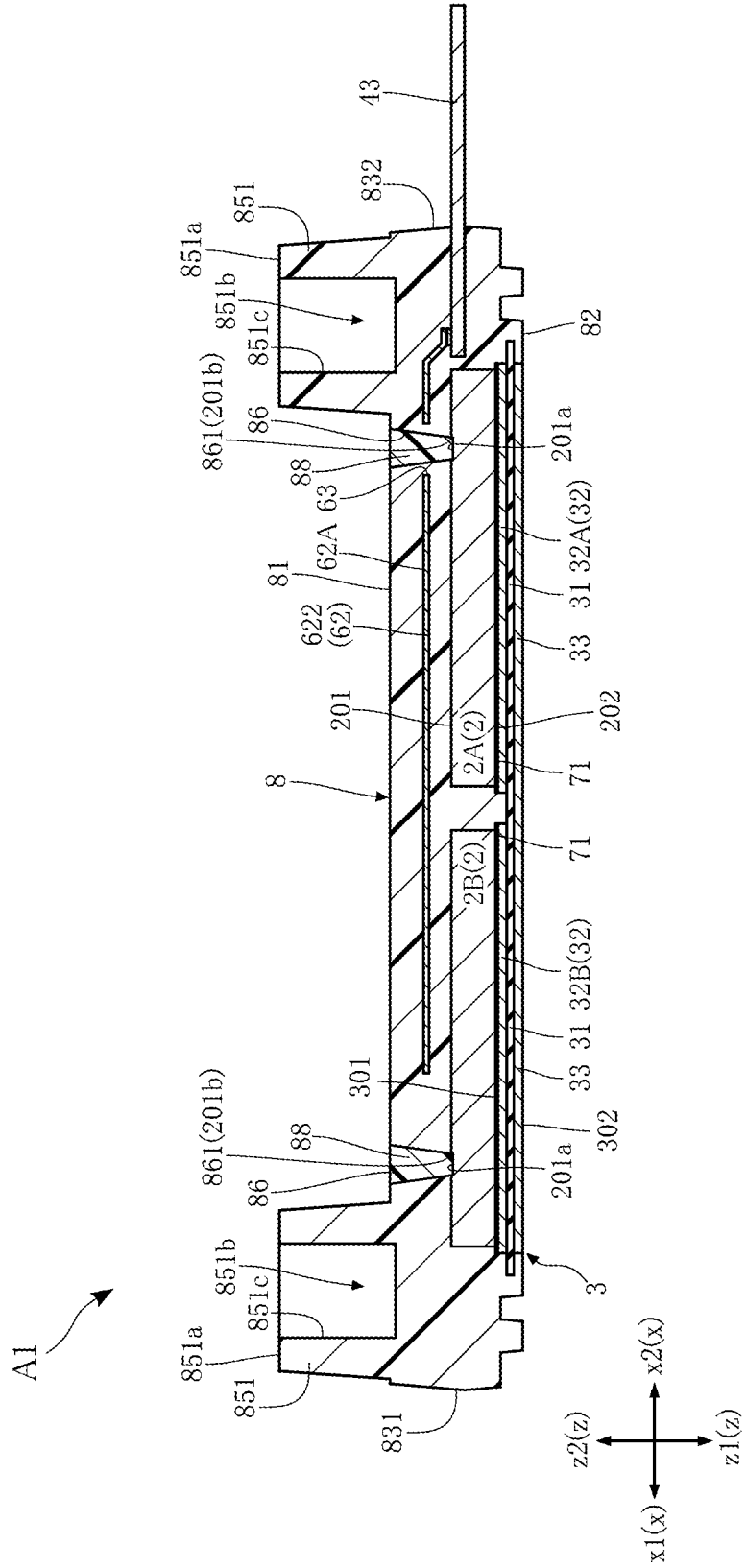

FIG. 14

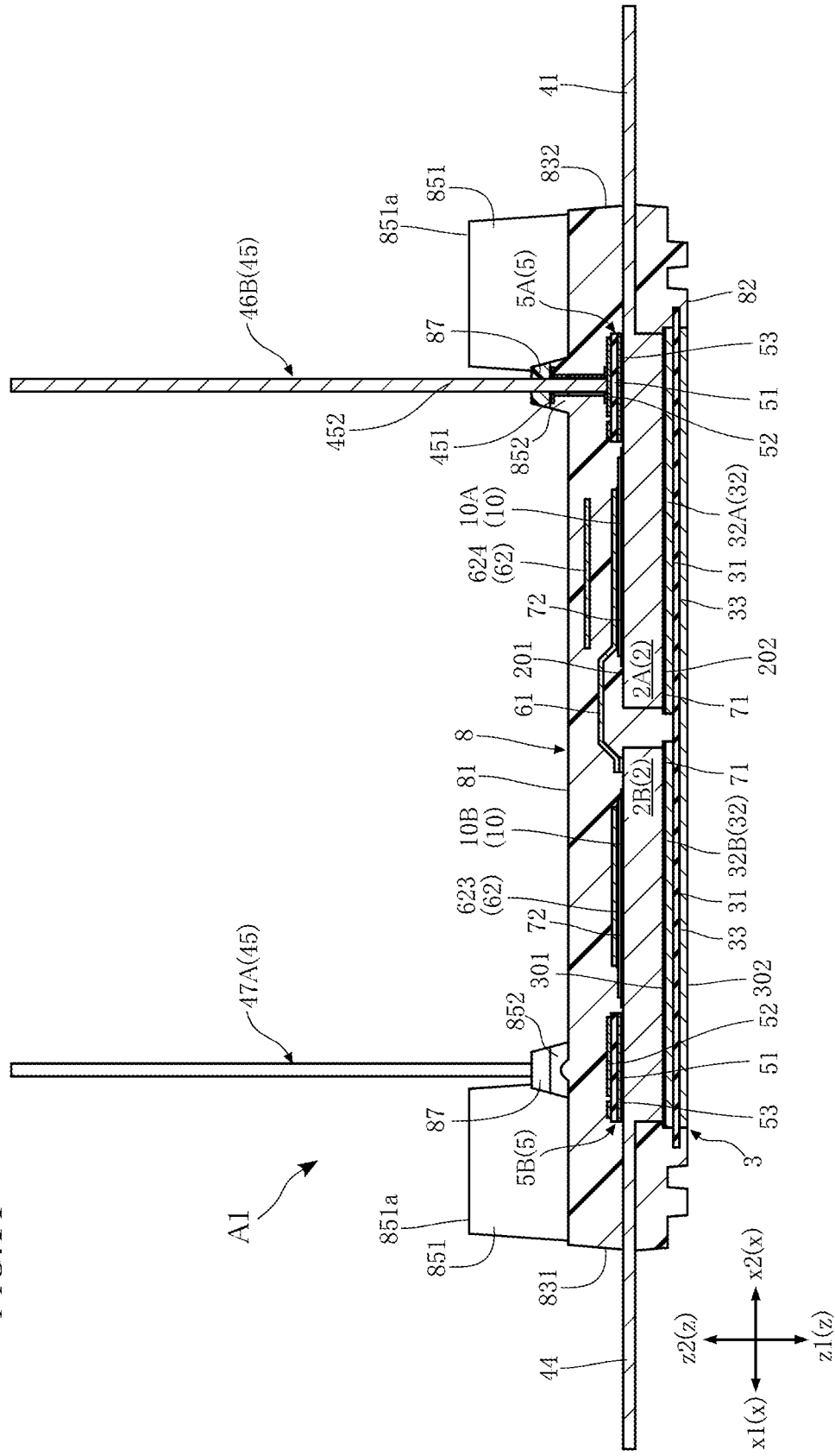

FIG. 15

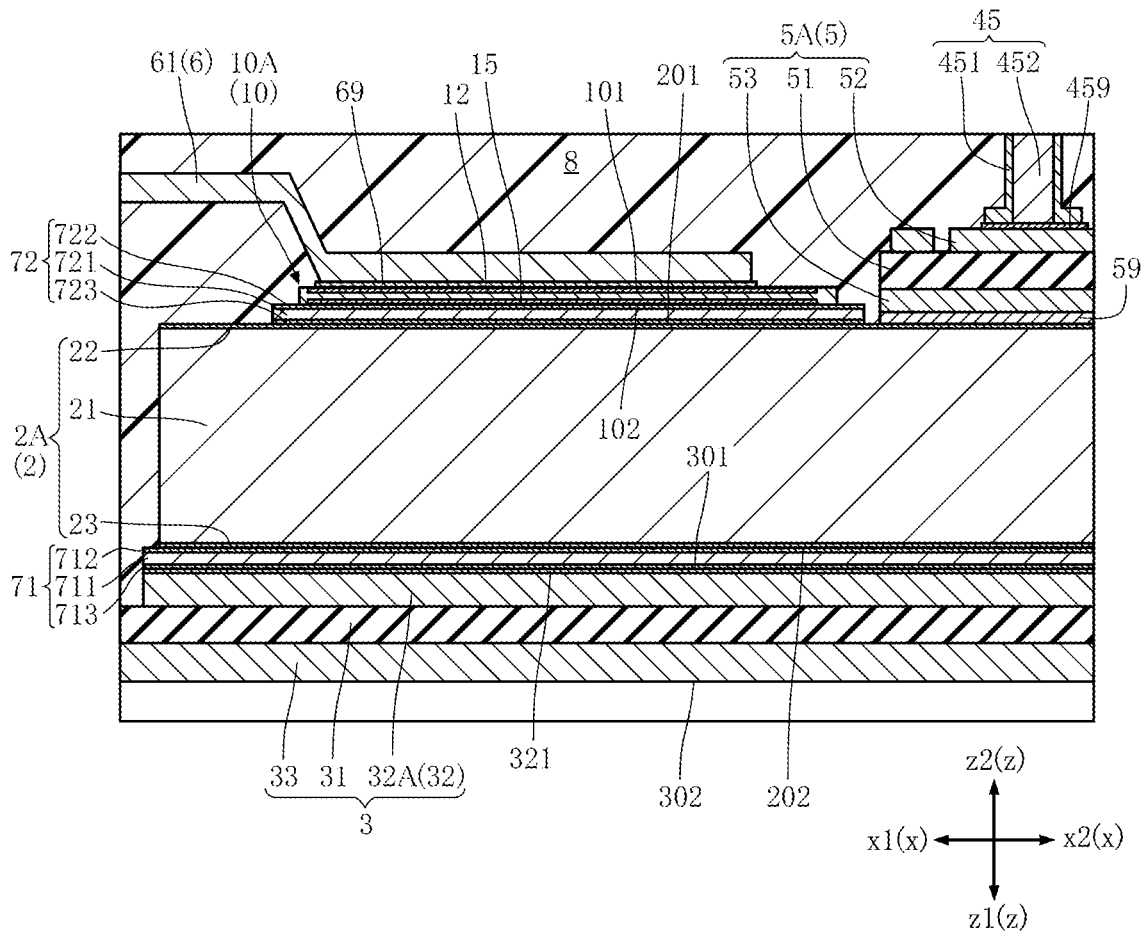

FIG.16

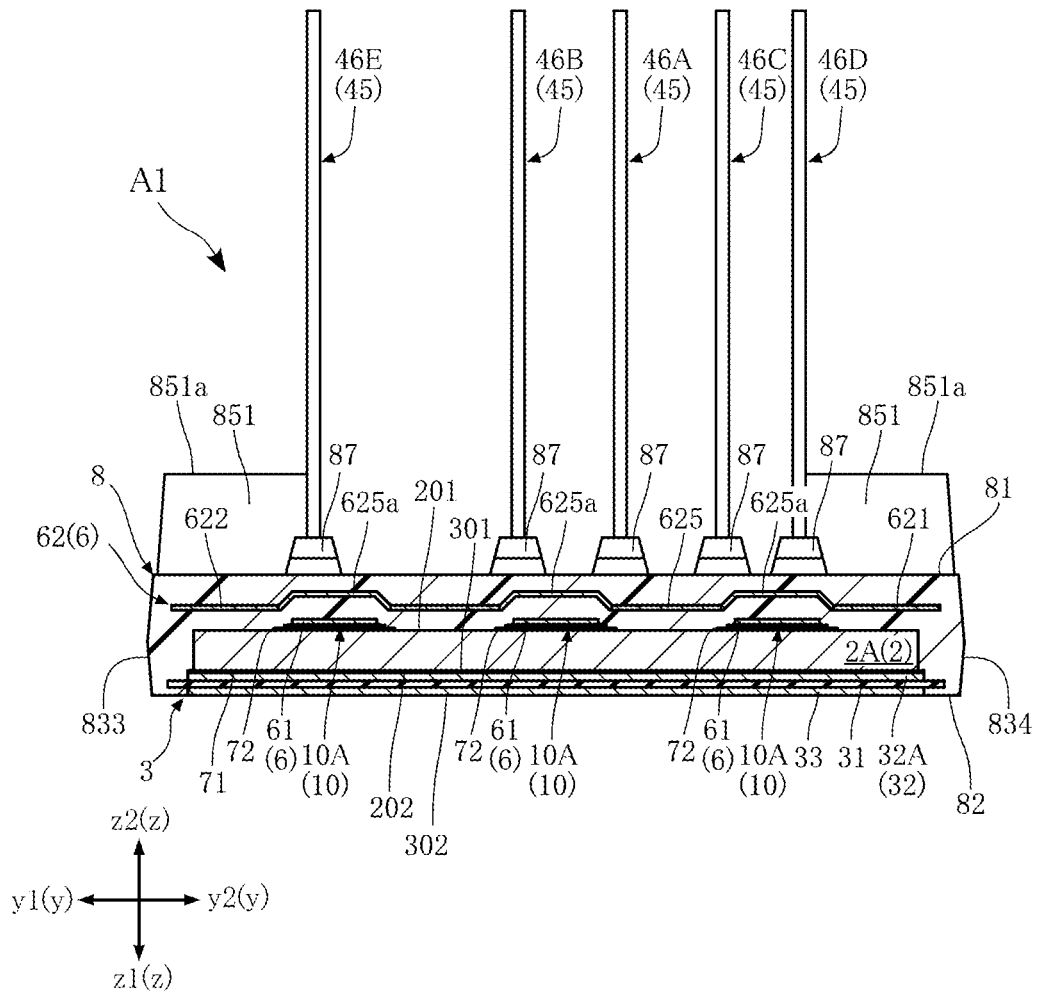

FIG. 17

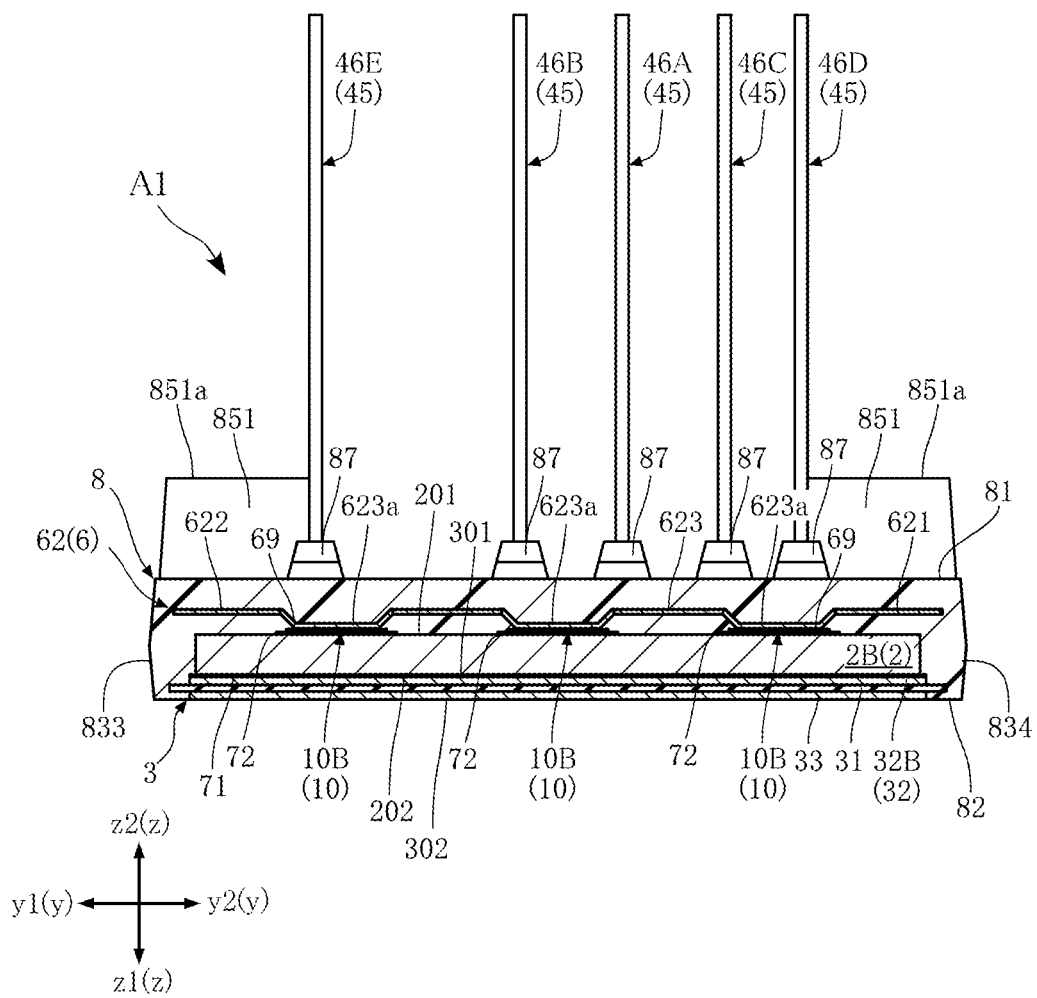

FIG.18

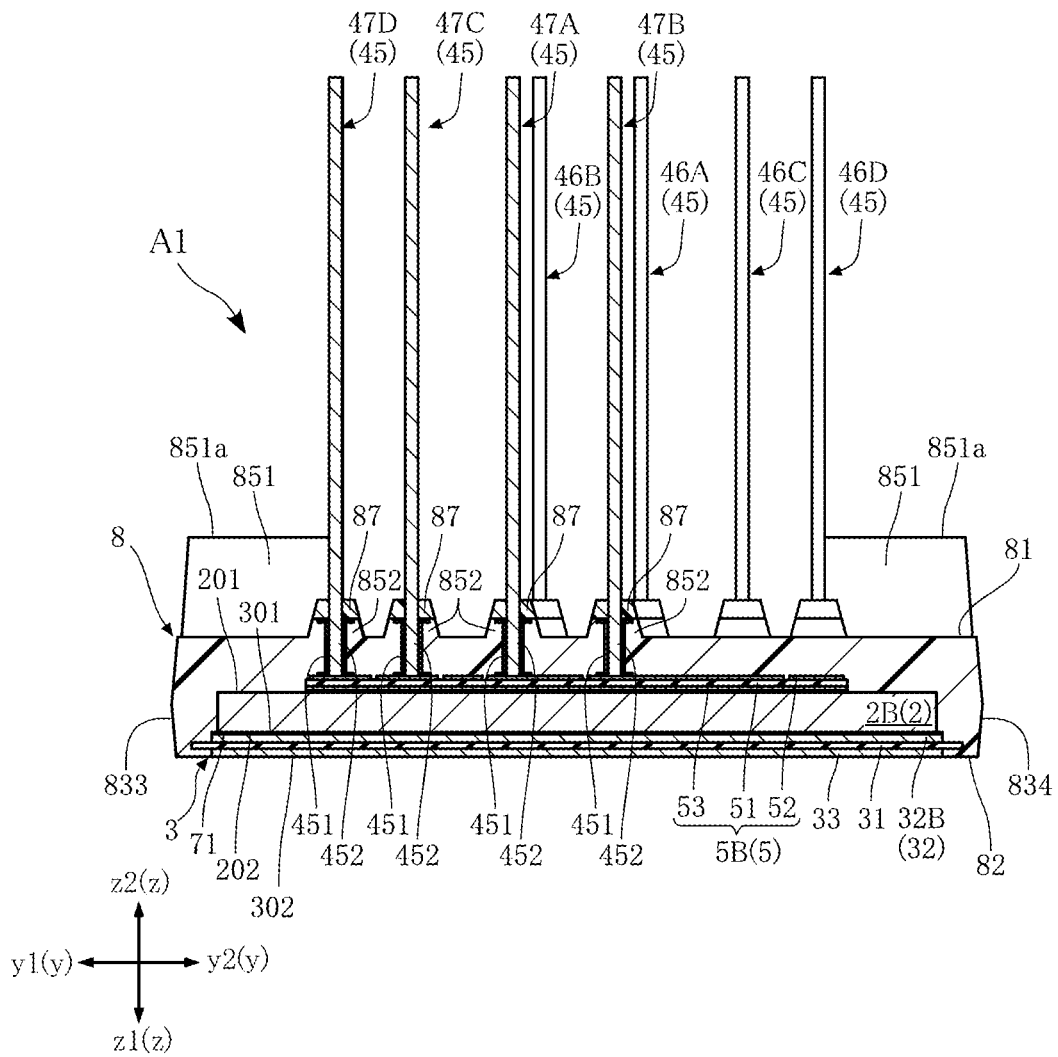

FIG. 19

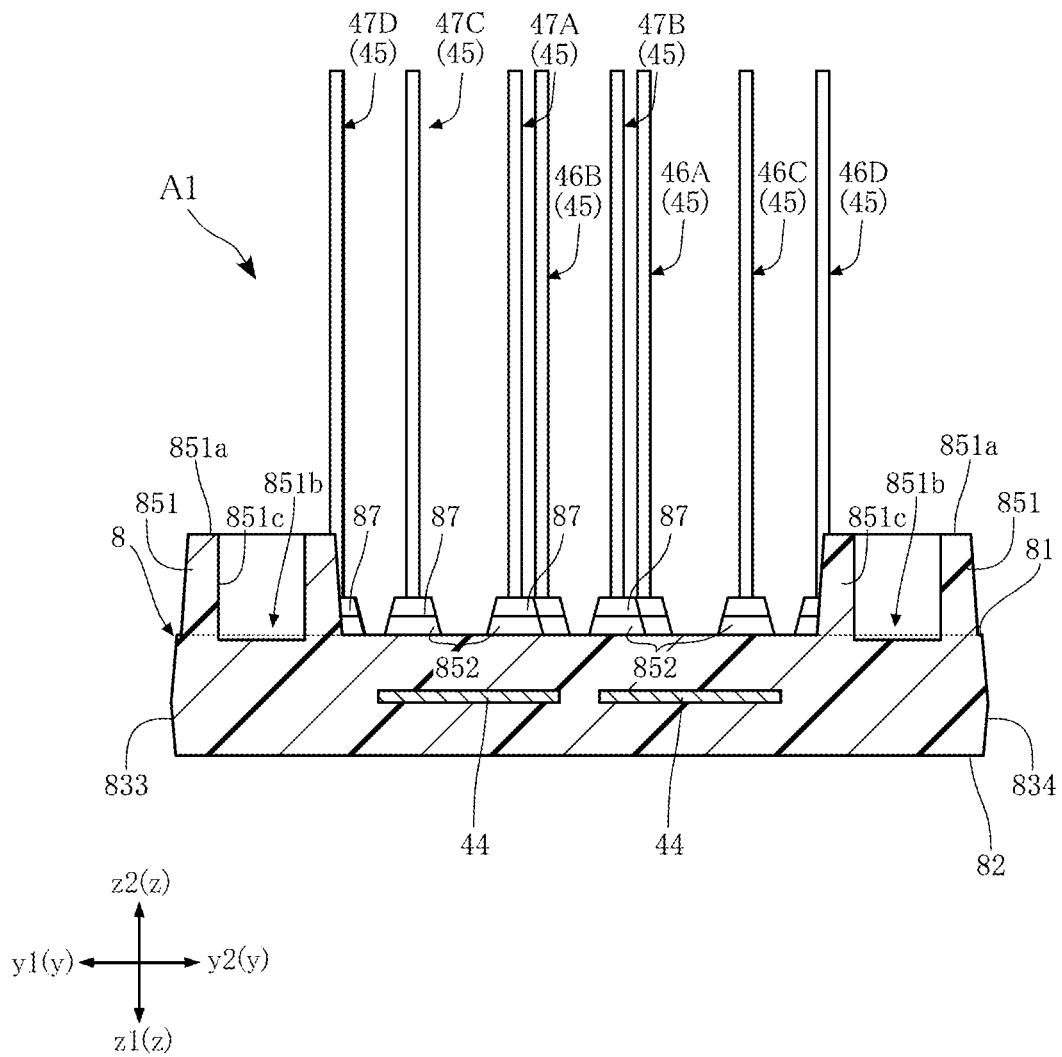
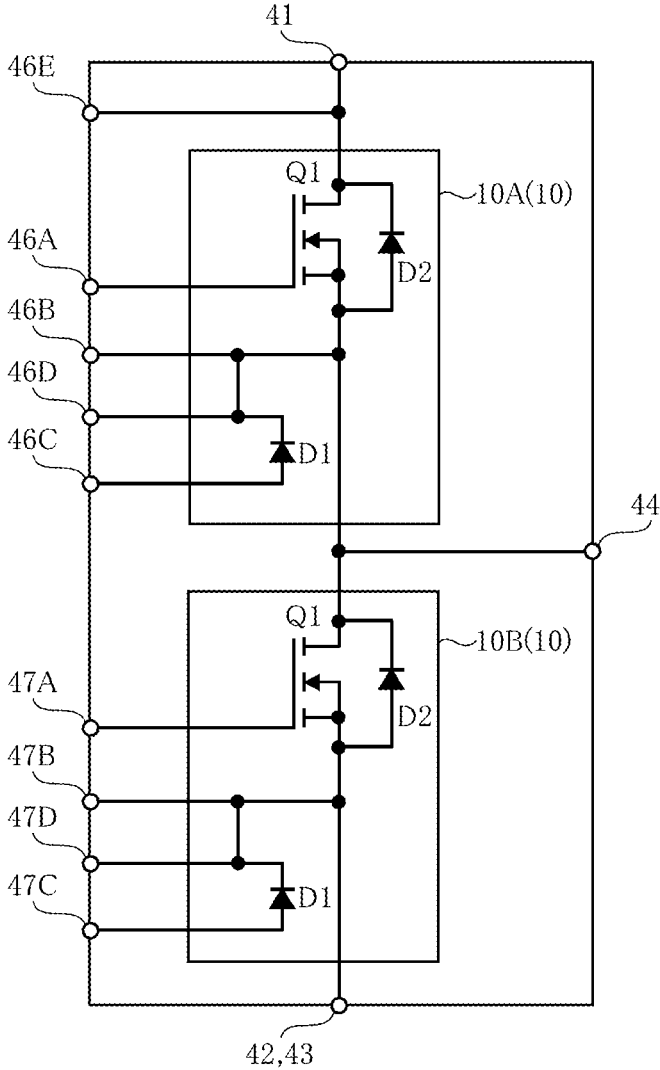

FIG. 20



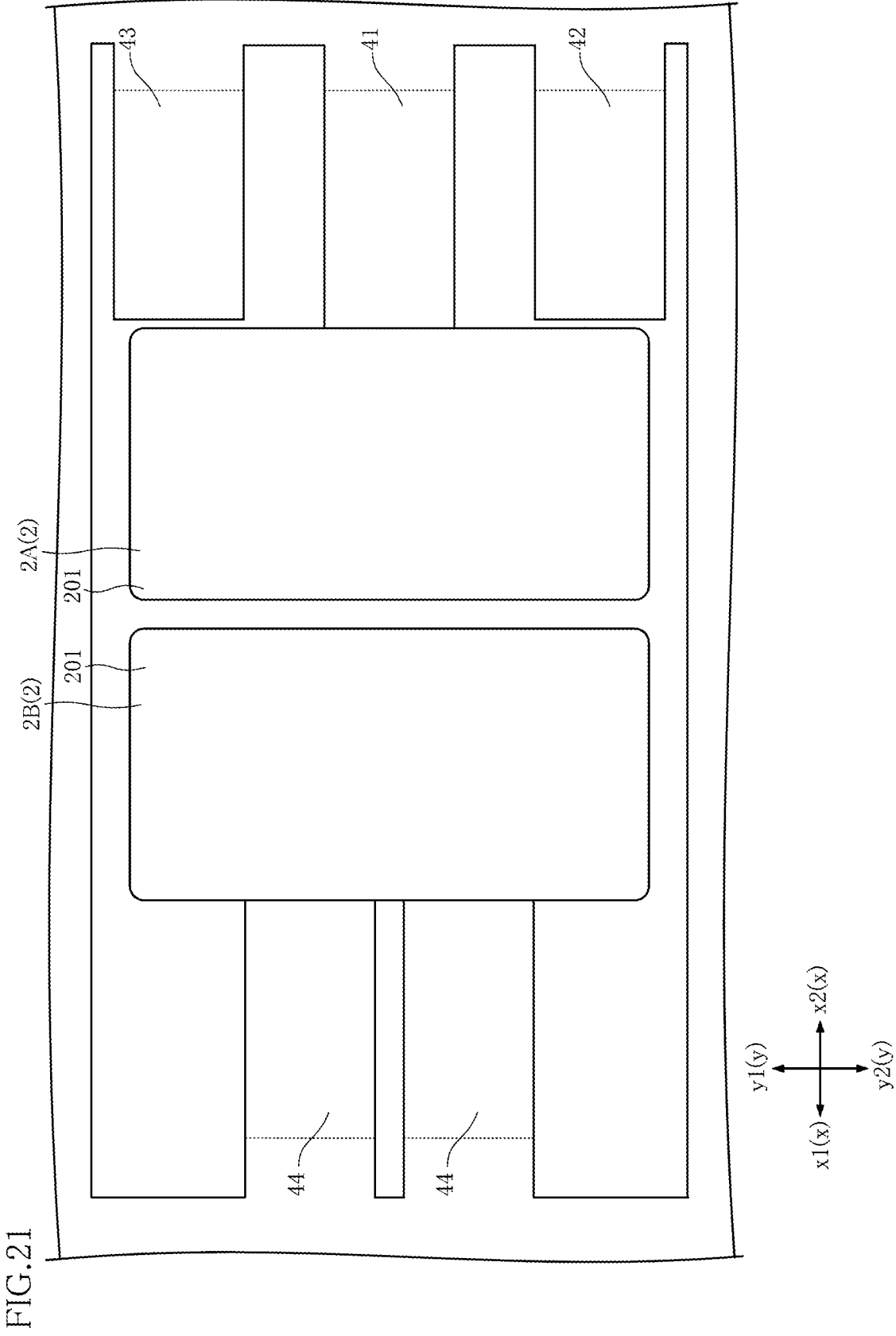



FIG. 23

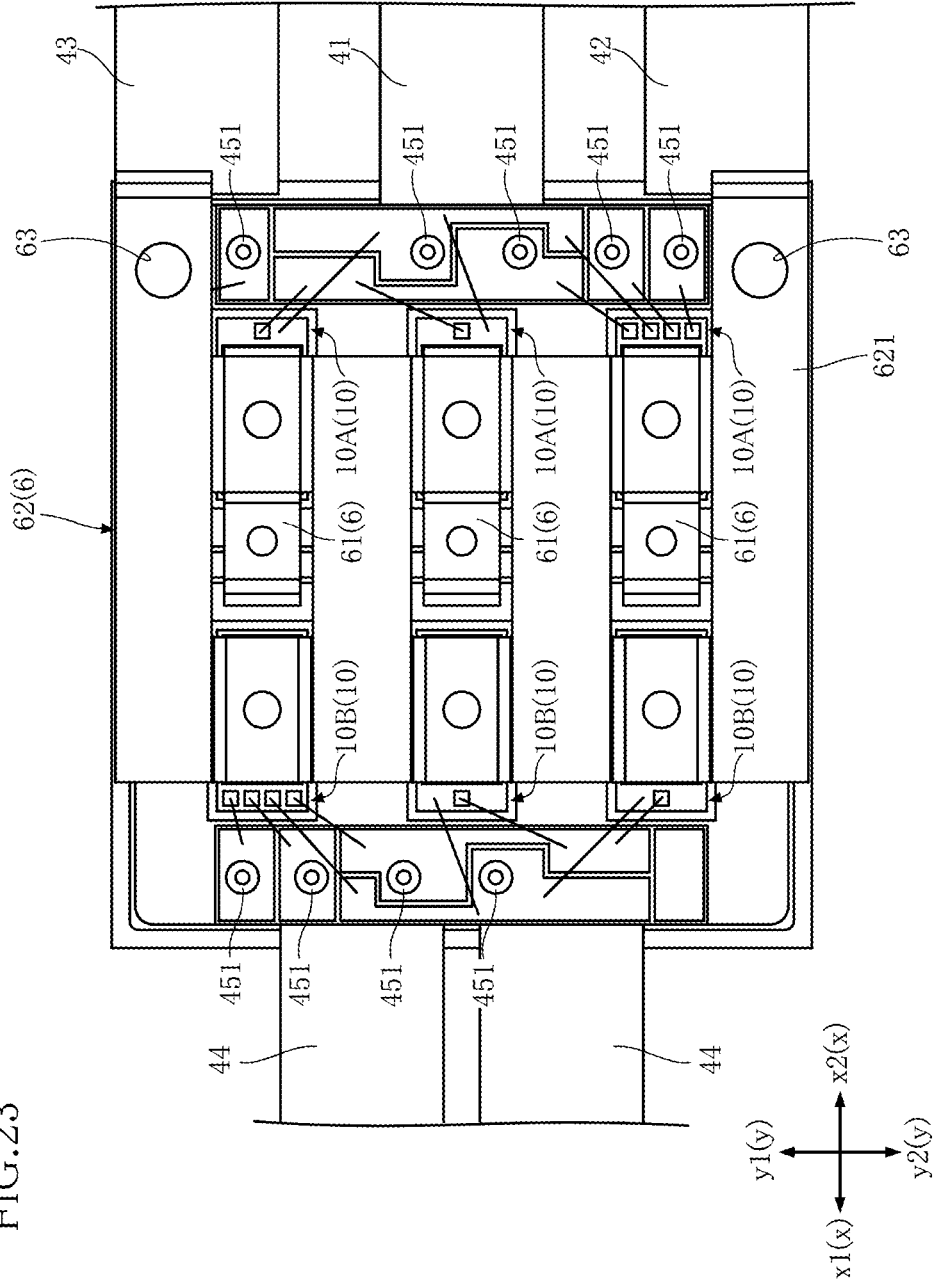

FIG. 24

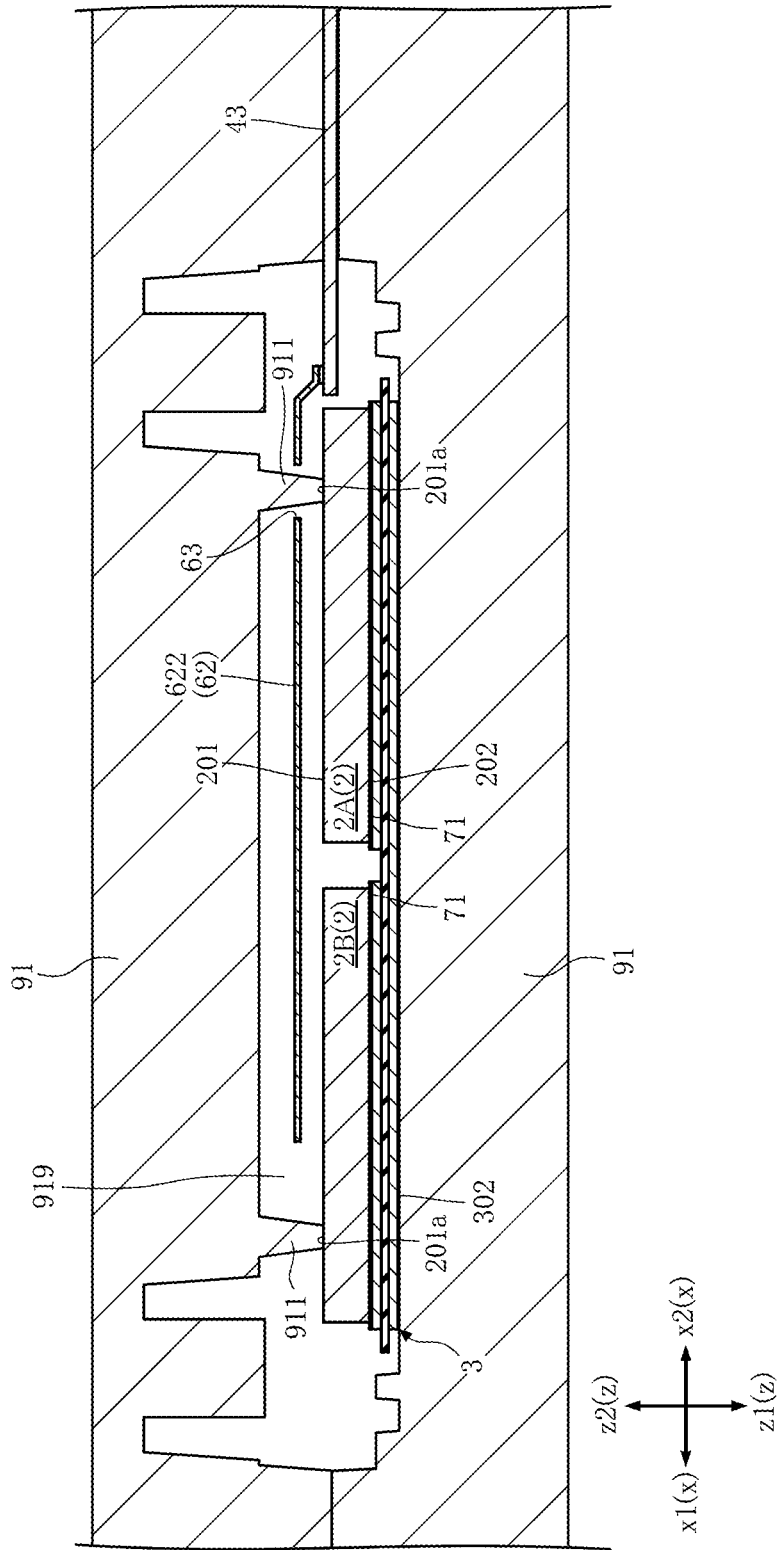

FIG.25

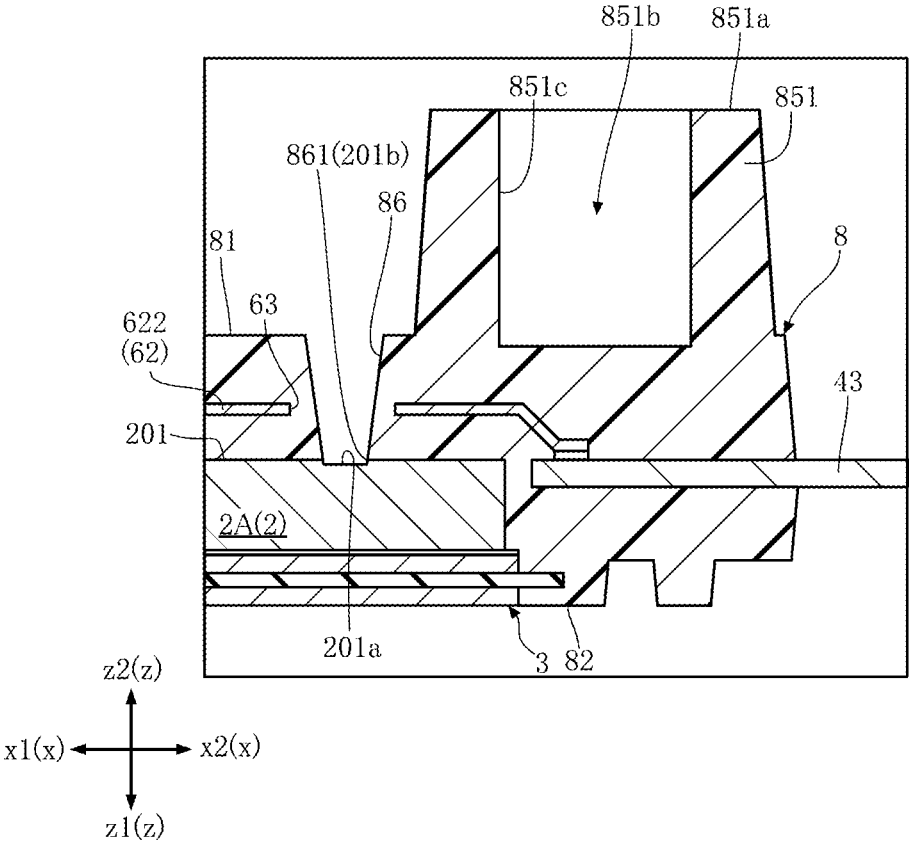

FIG.26

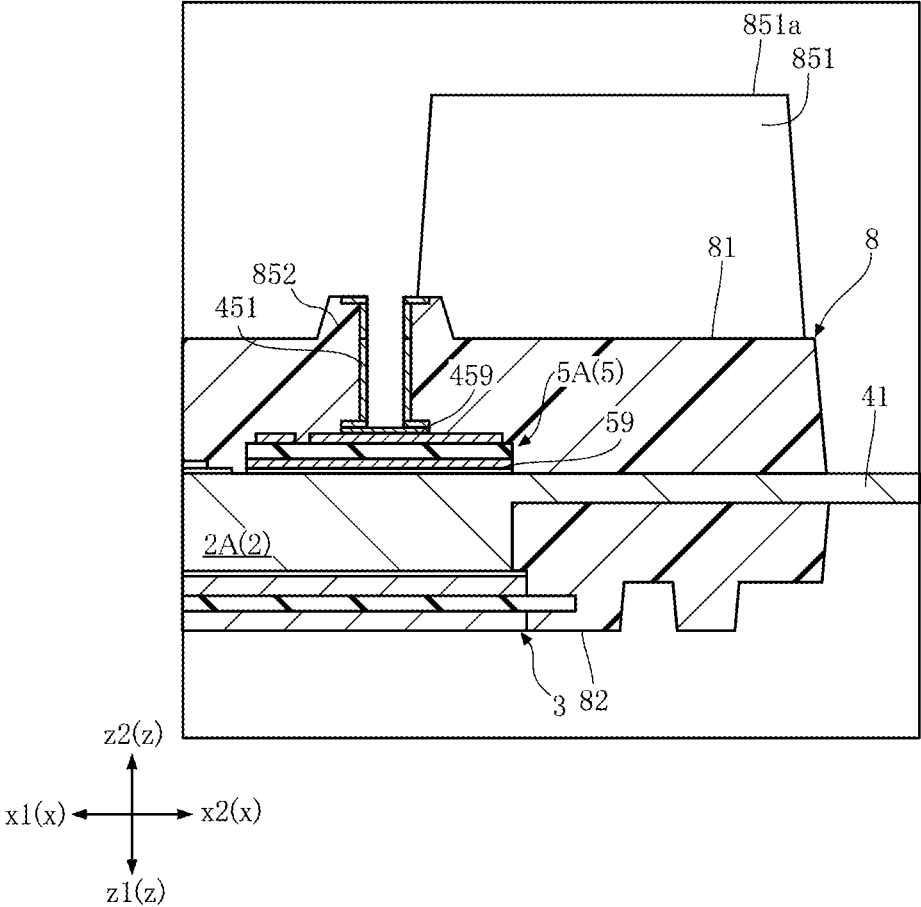

FIG.27

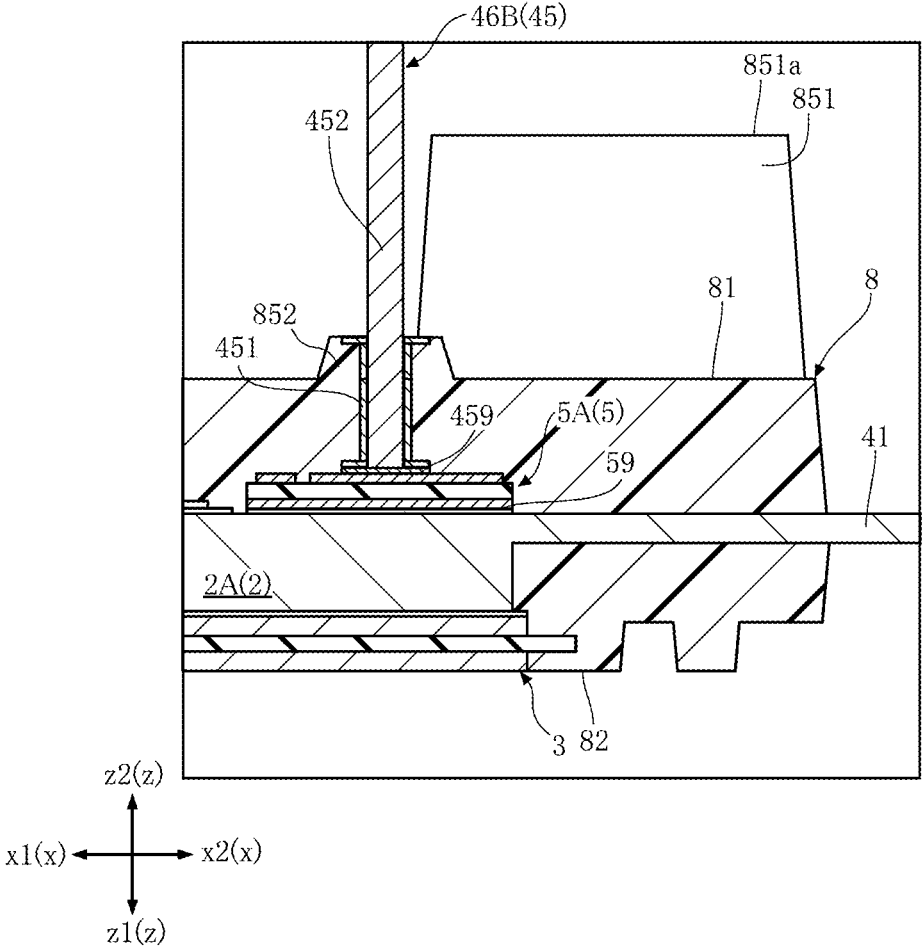

FIG.28

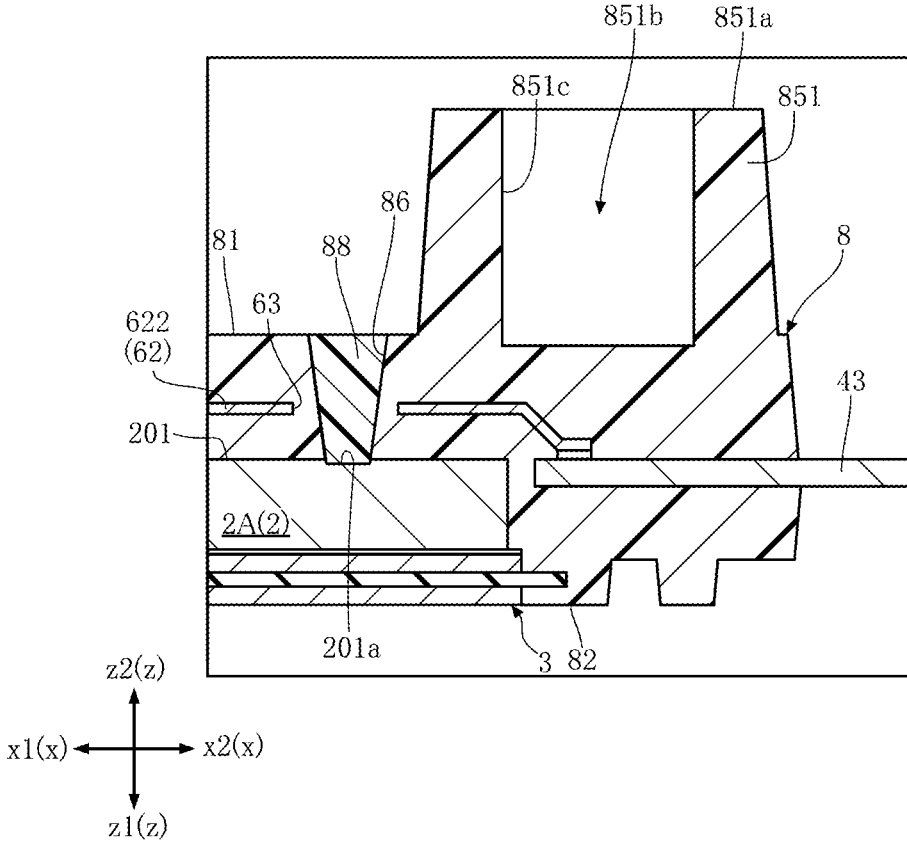

FIG.29

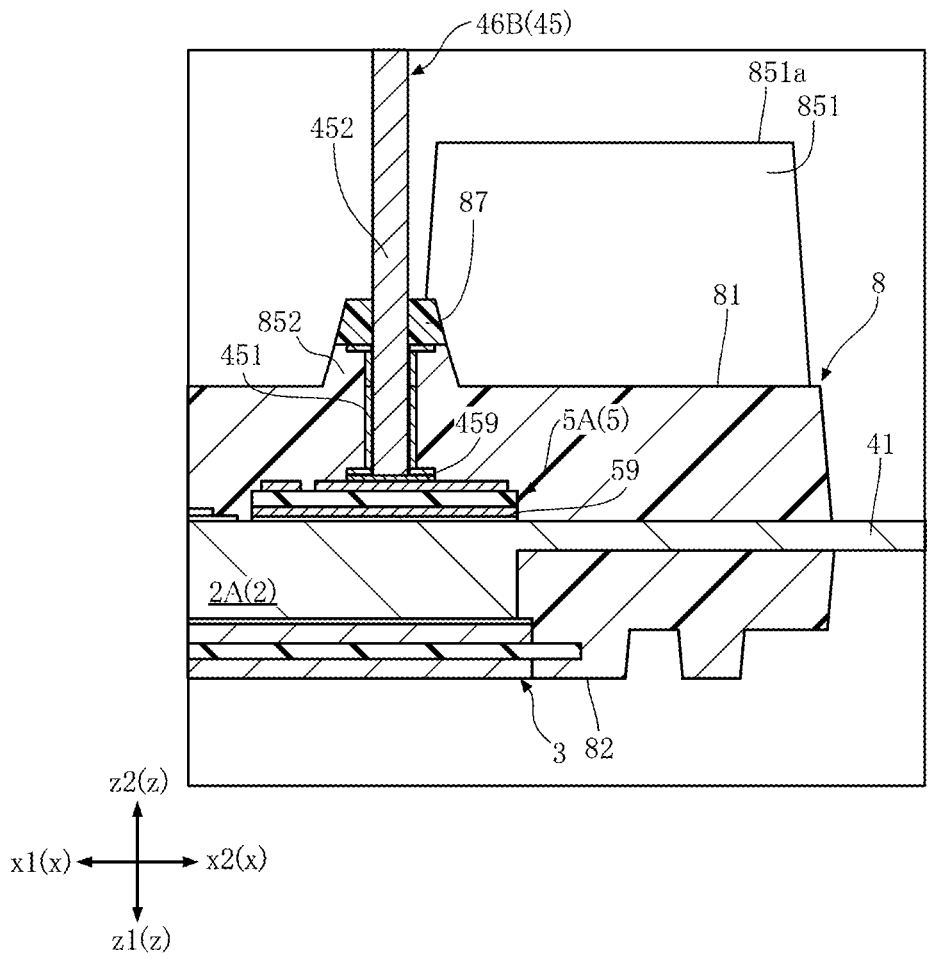

FIG. 30

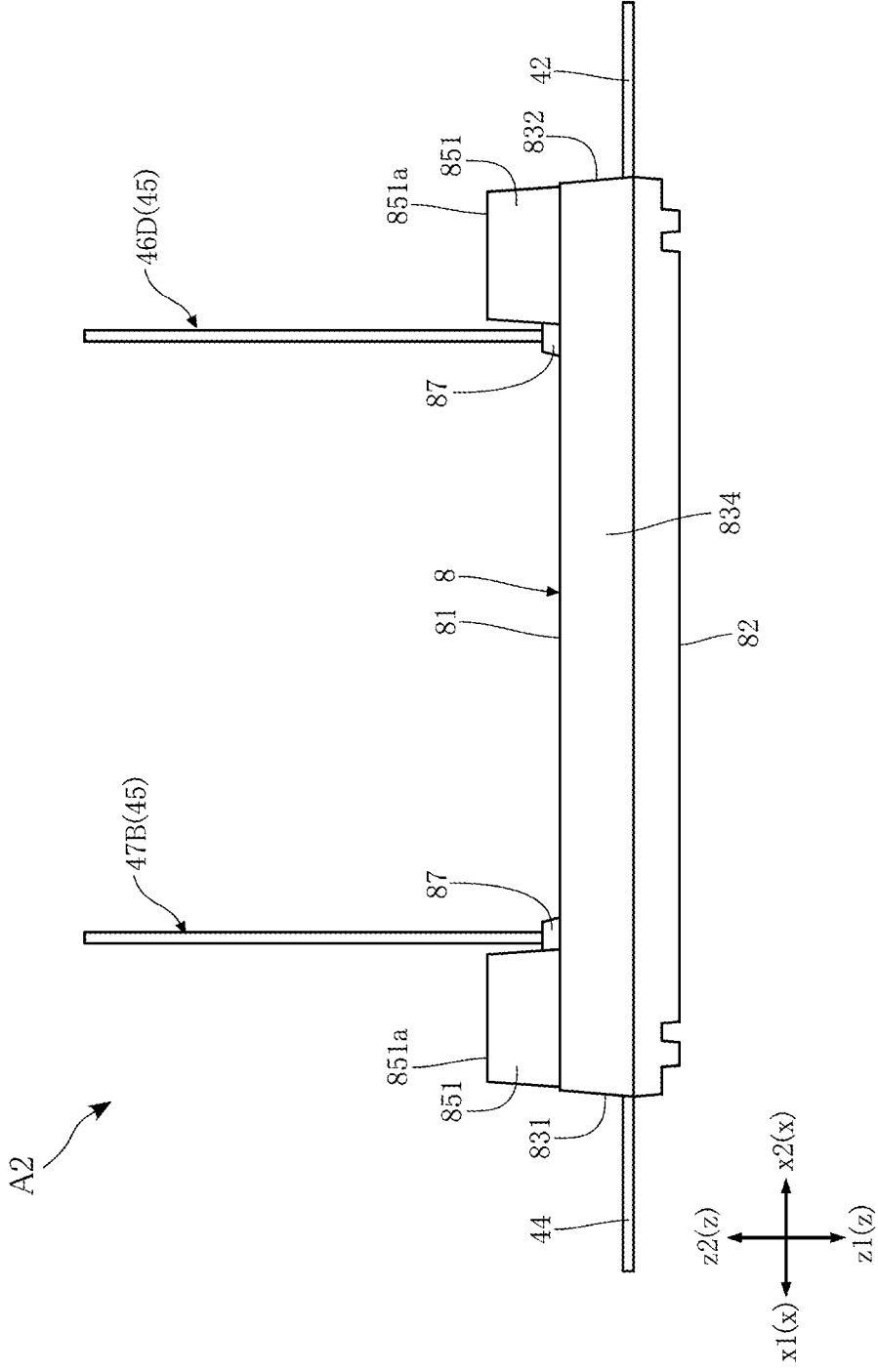

FIG.31

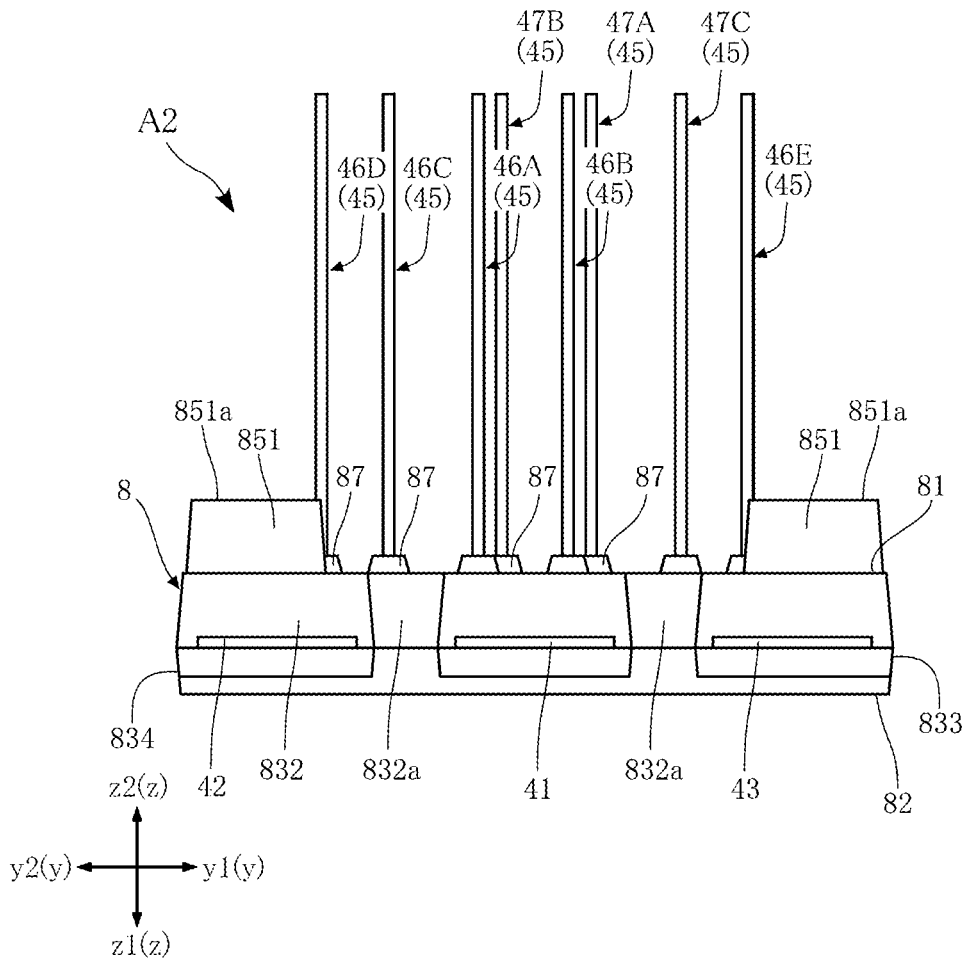

FIG.32

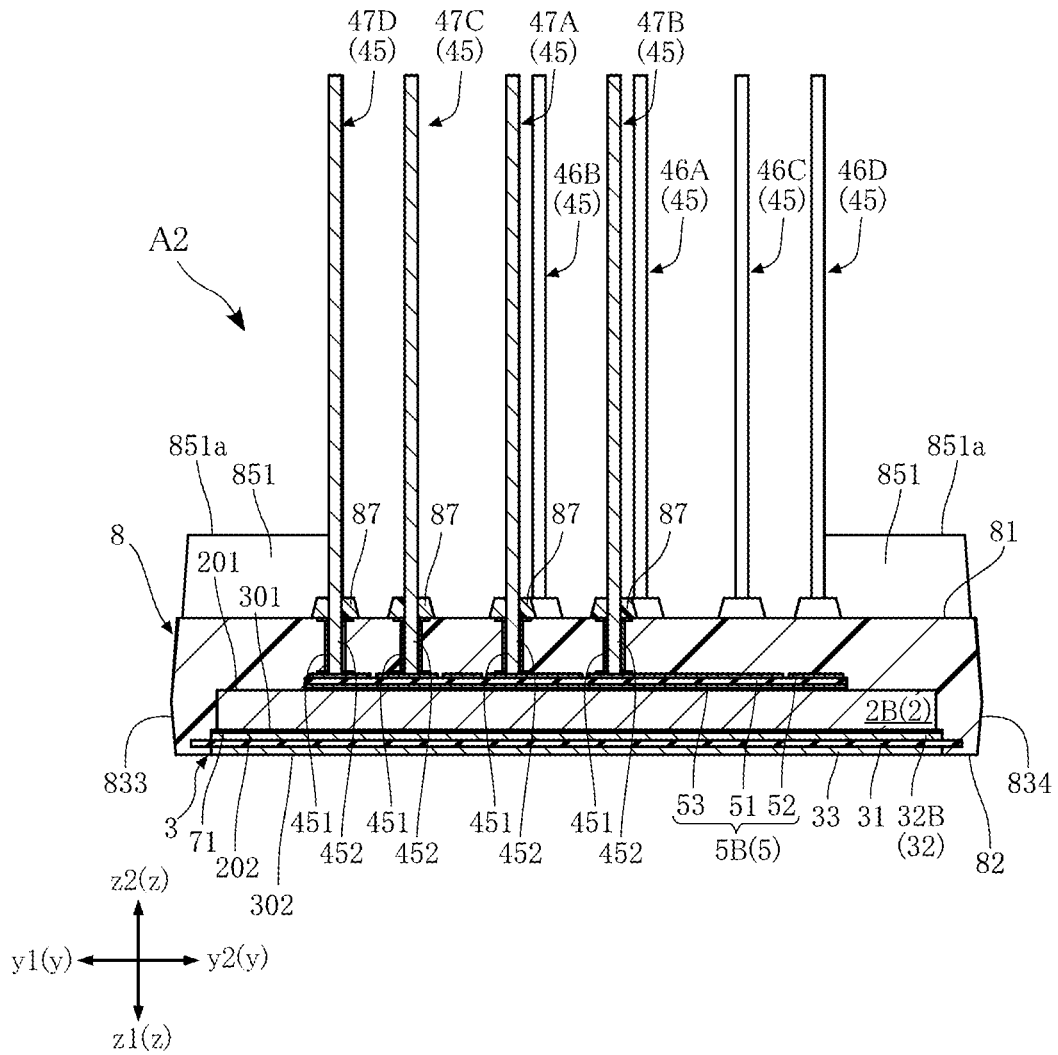

FIG. 33

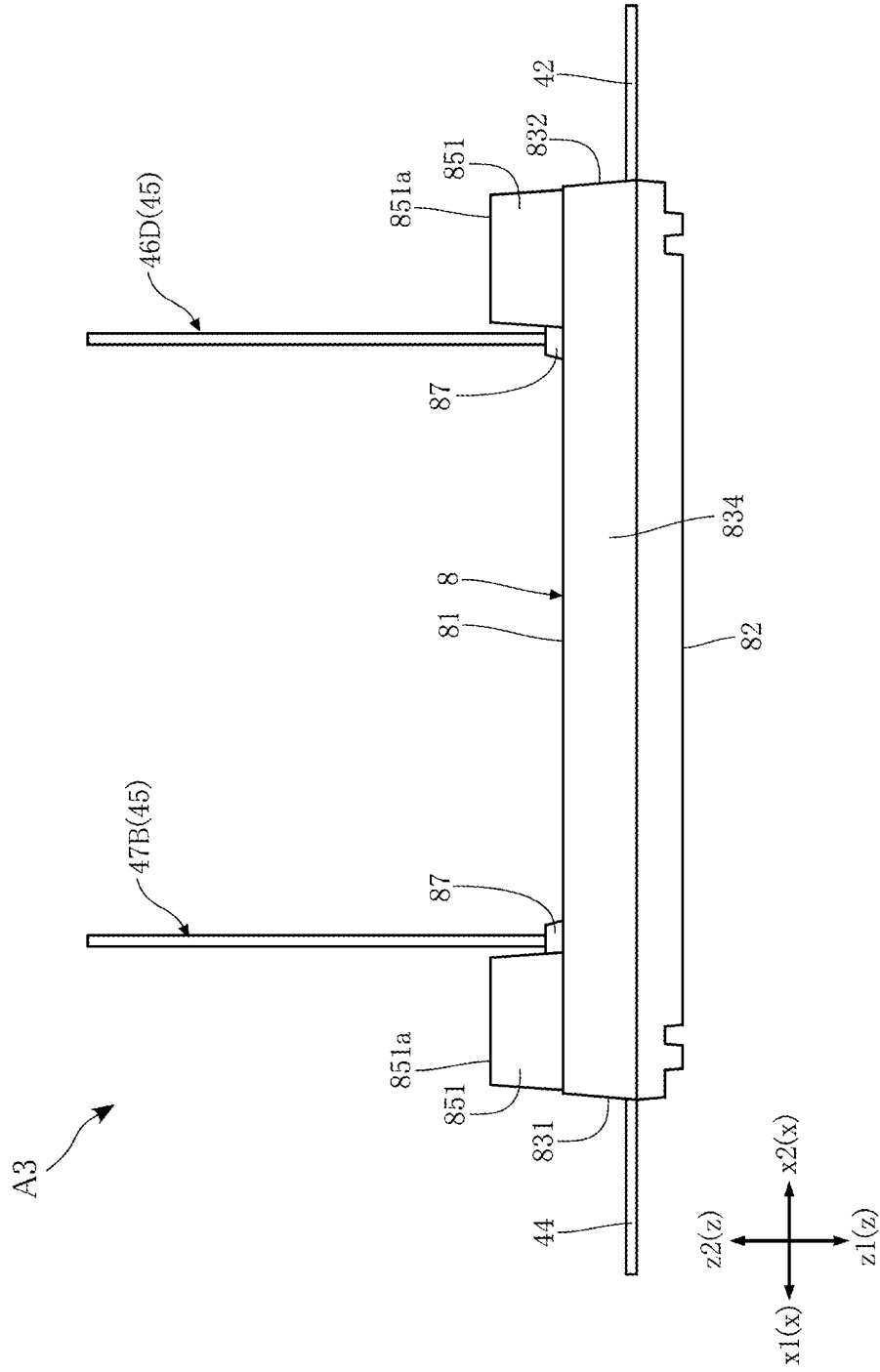

FIG.34

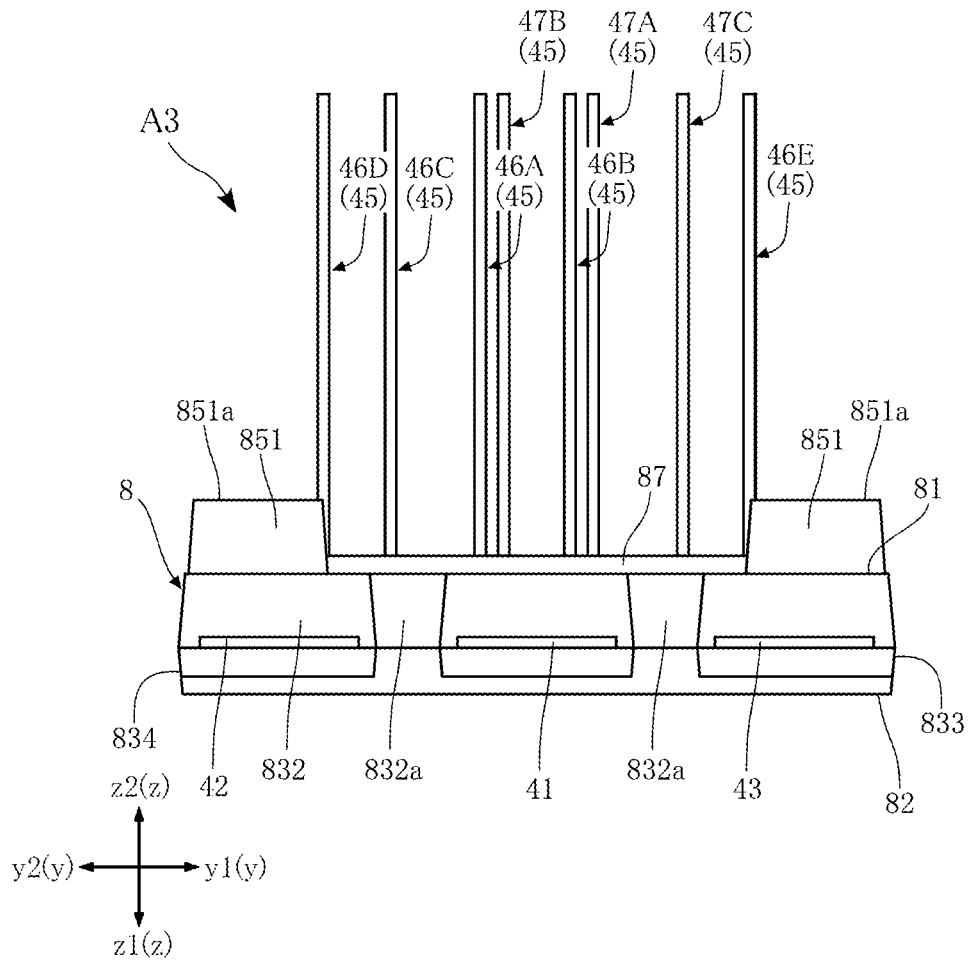

FIG.35

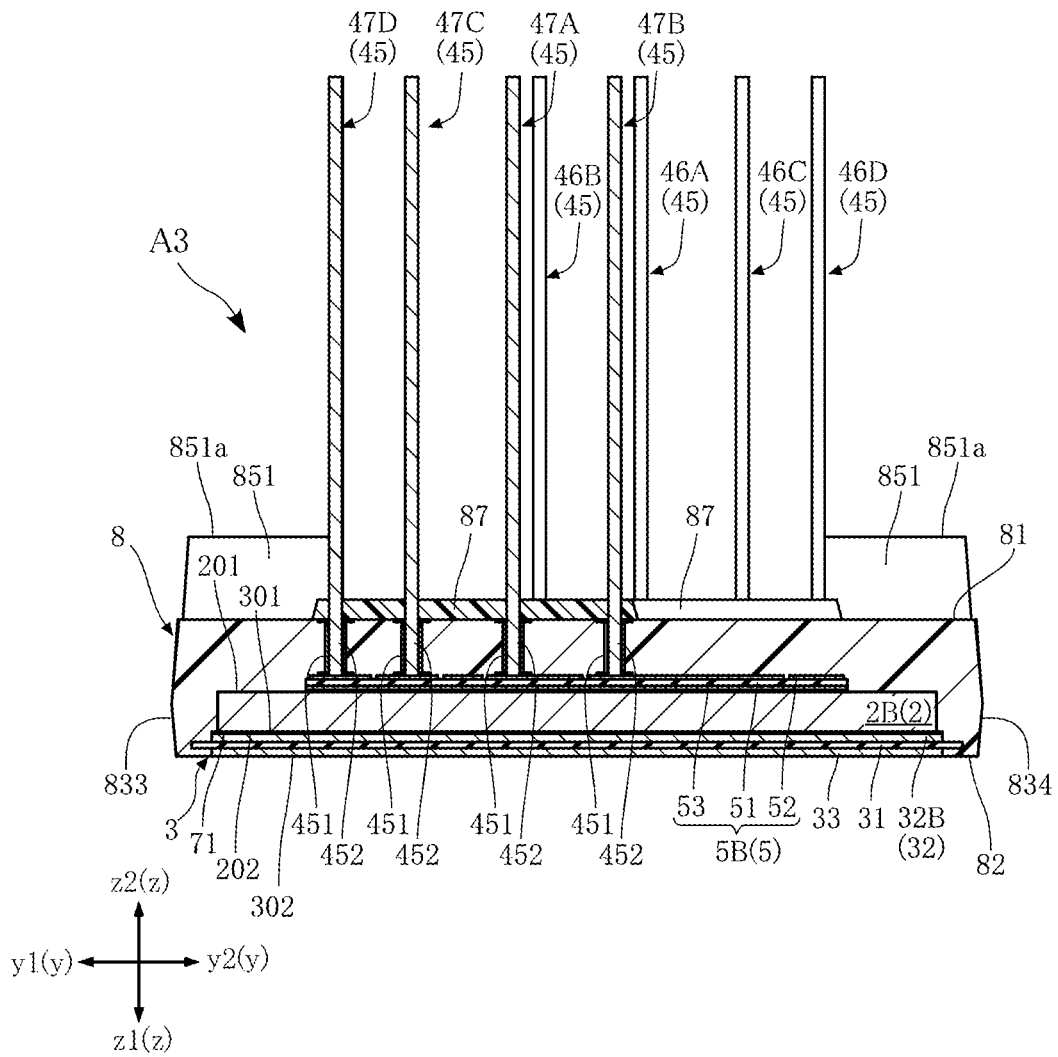

FIG. 36

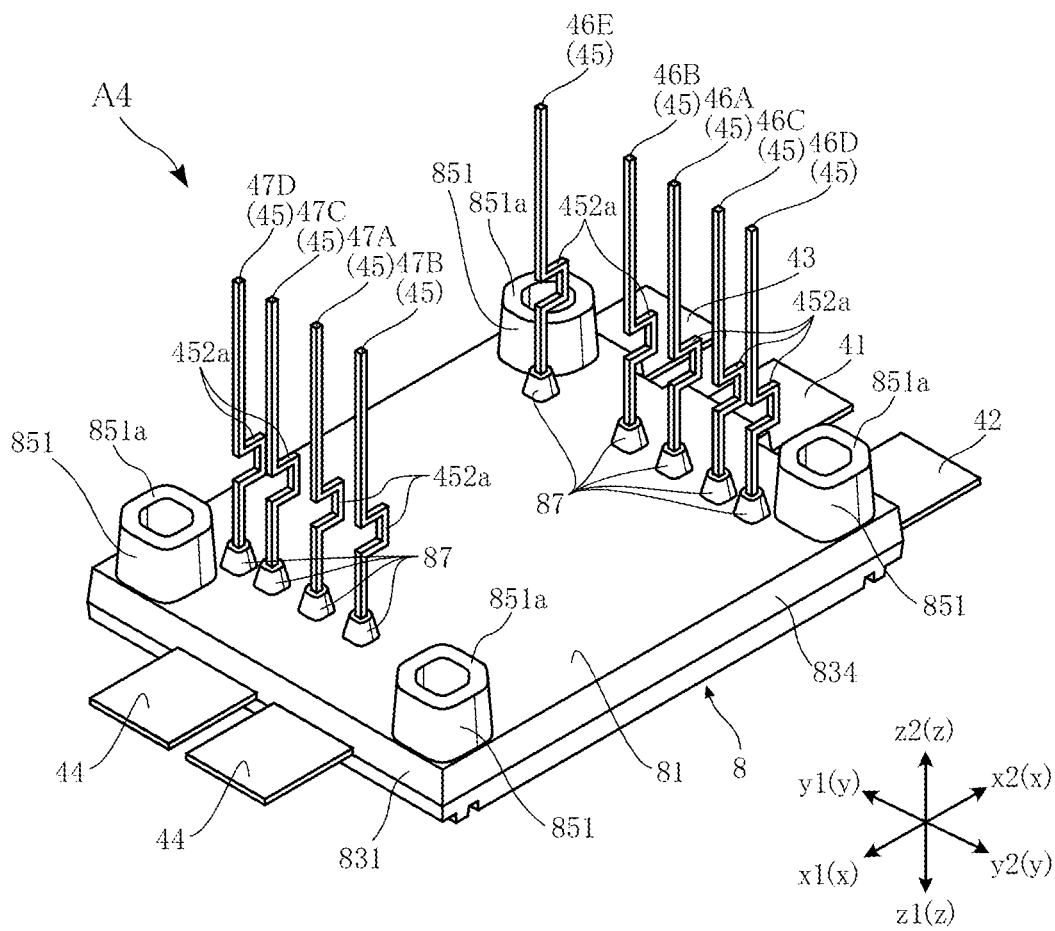
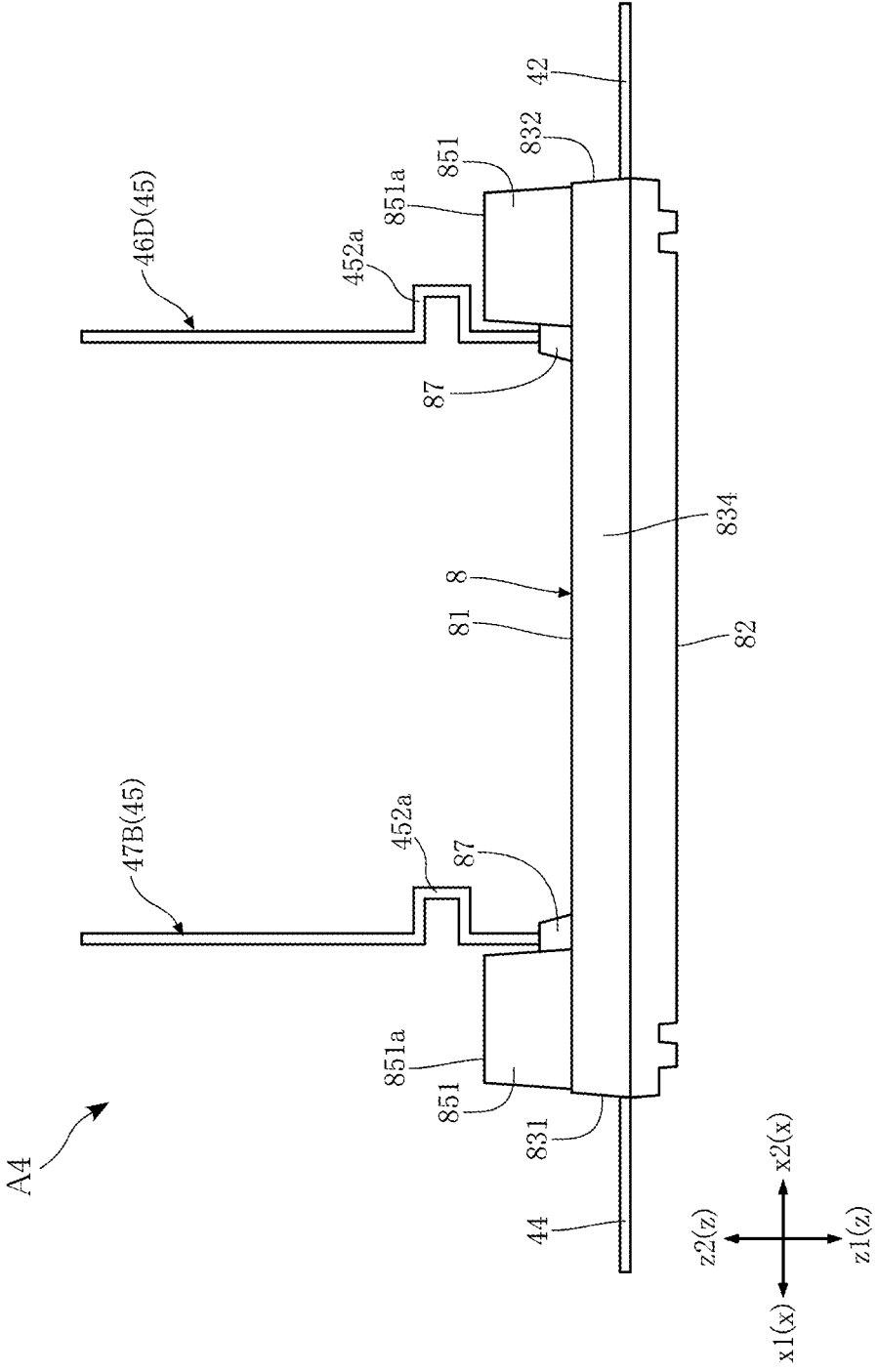
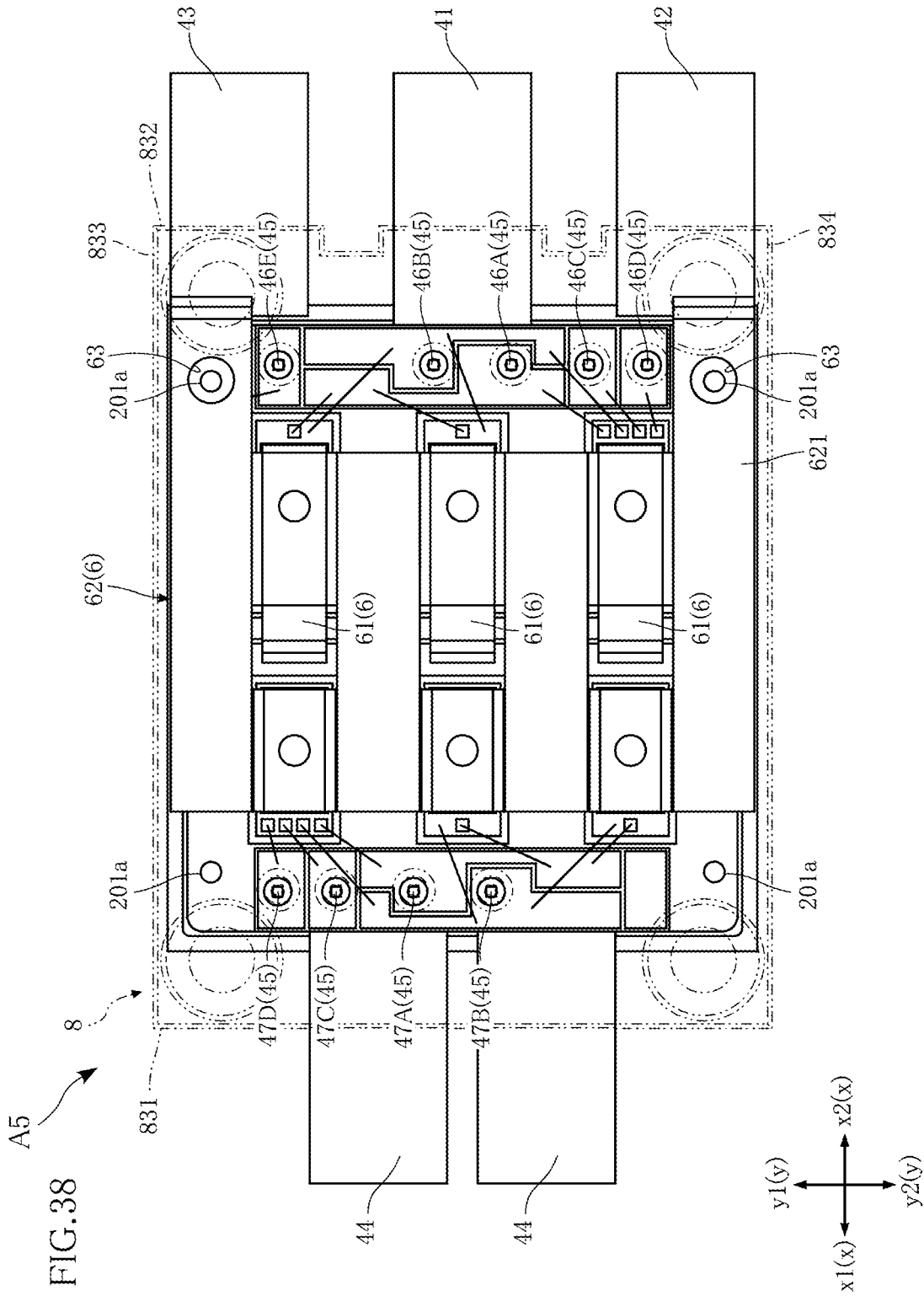

FIG. 37





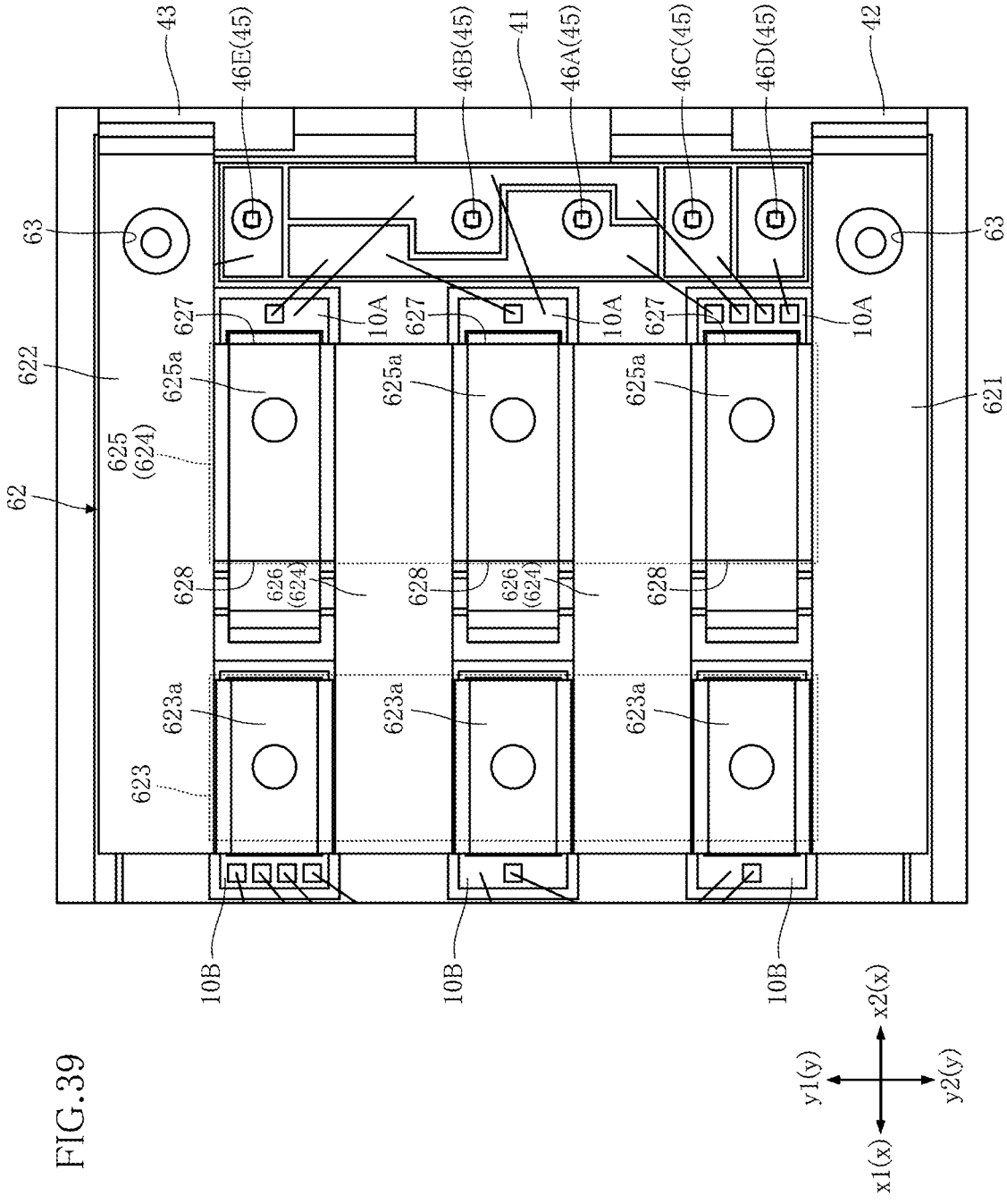
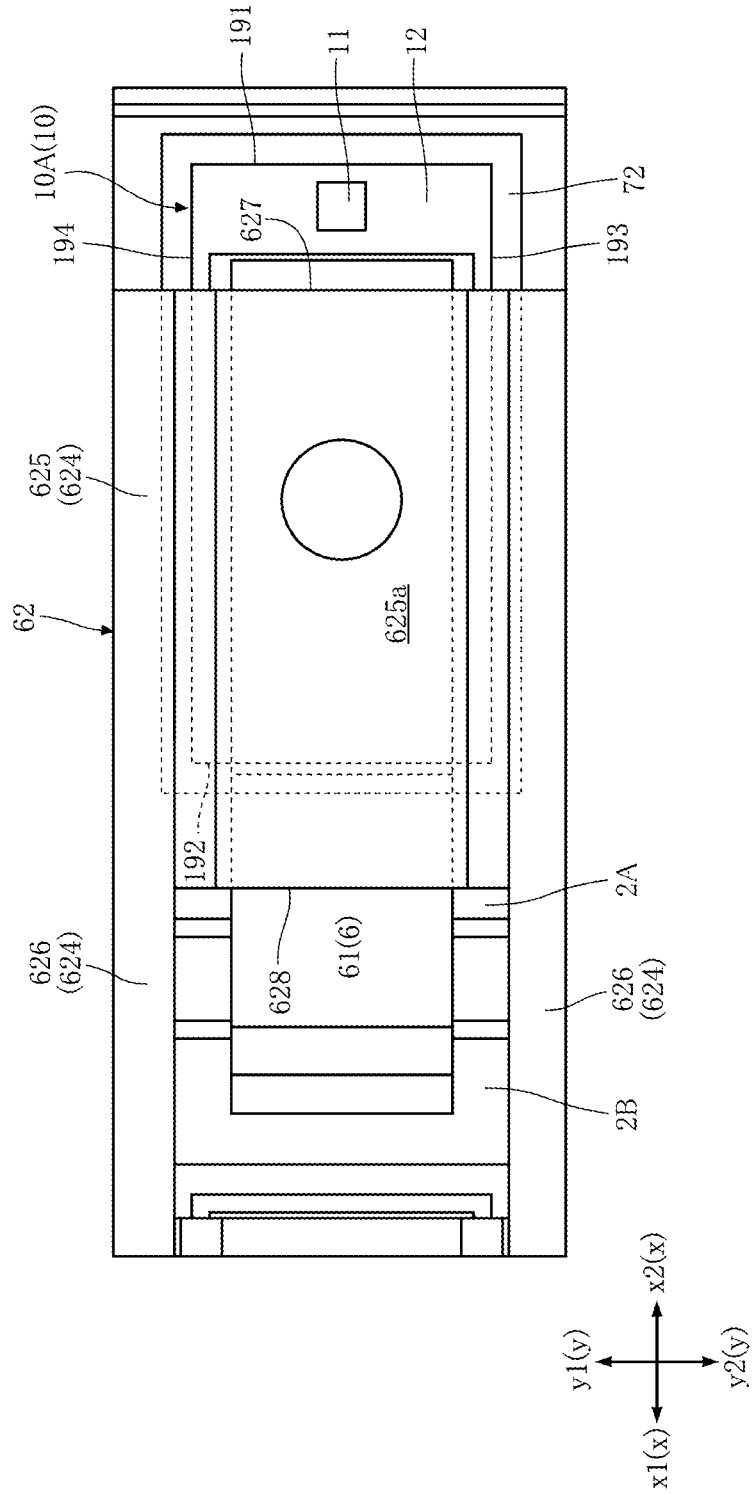

FIG. 40



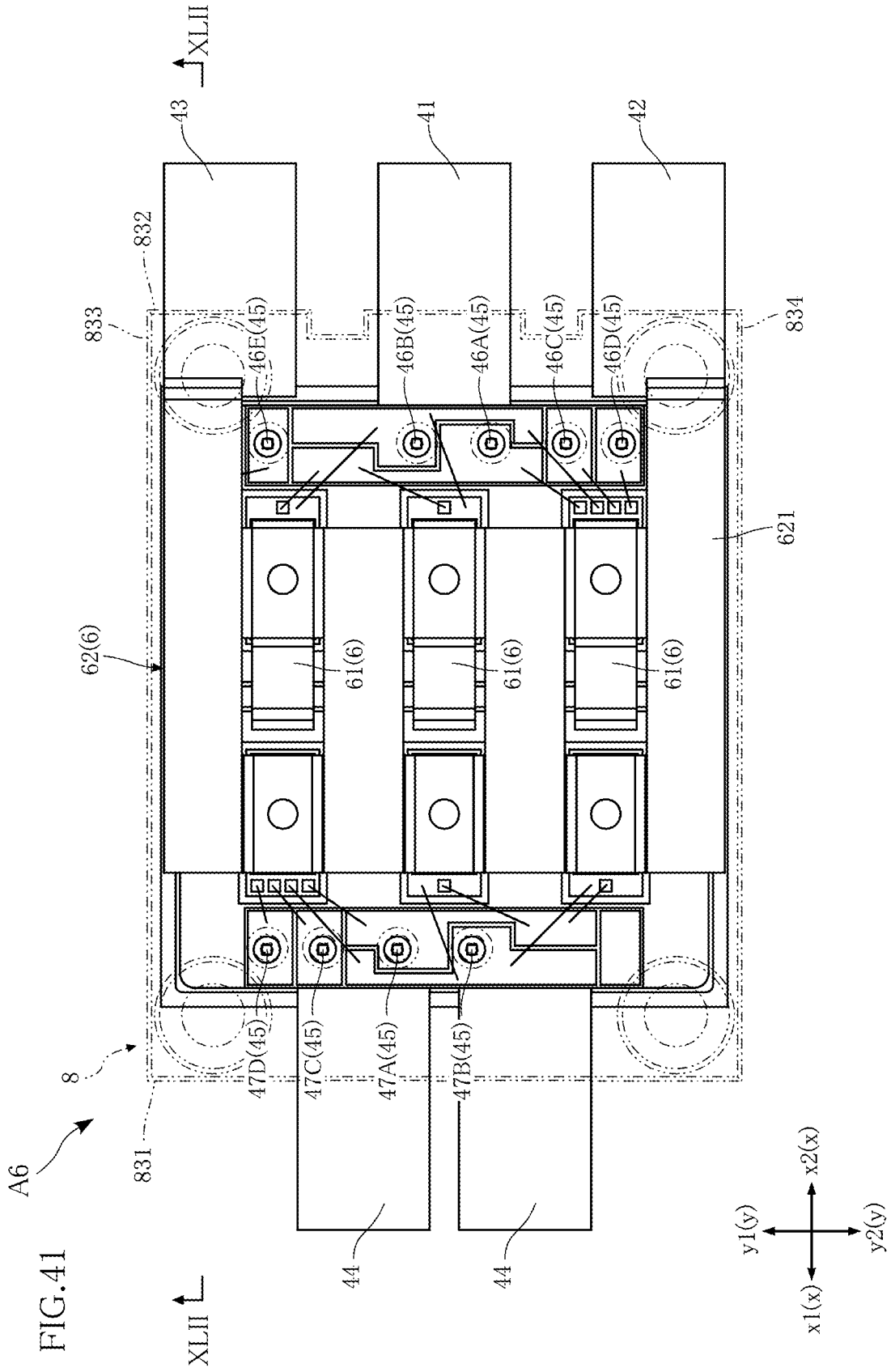
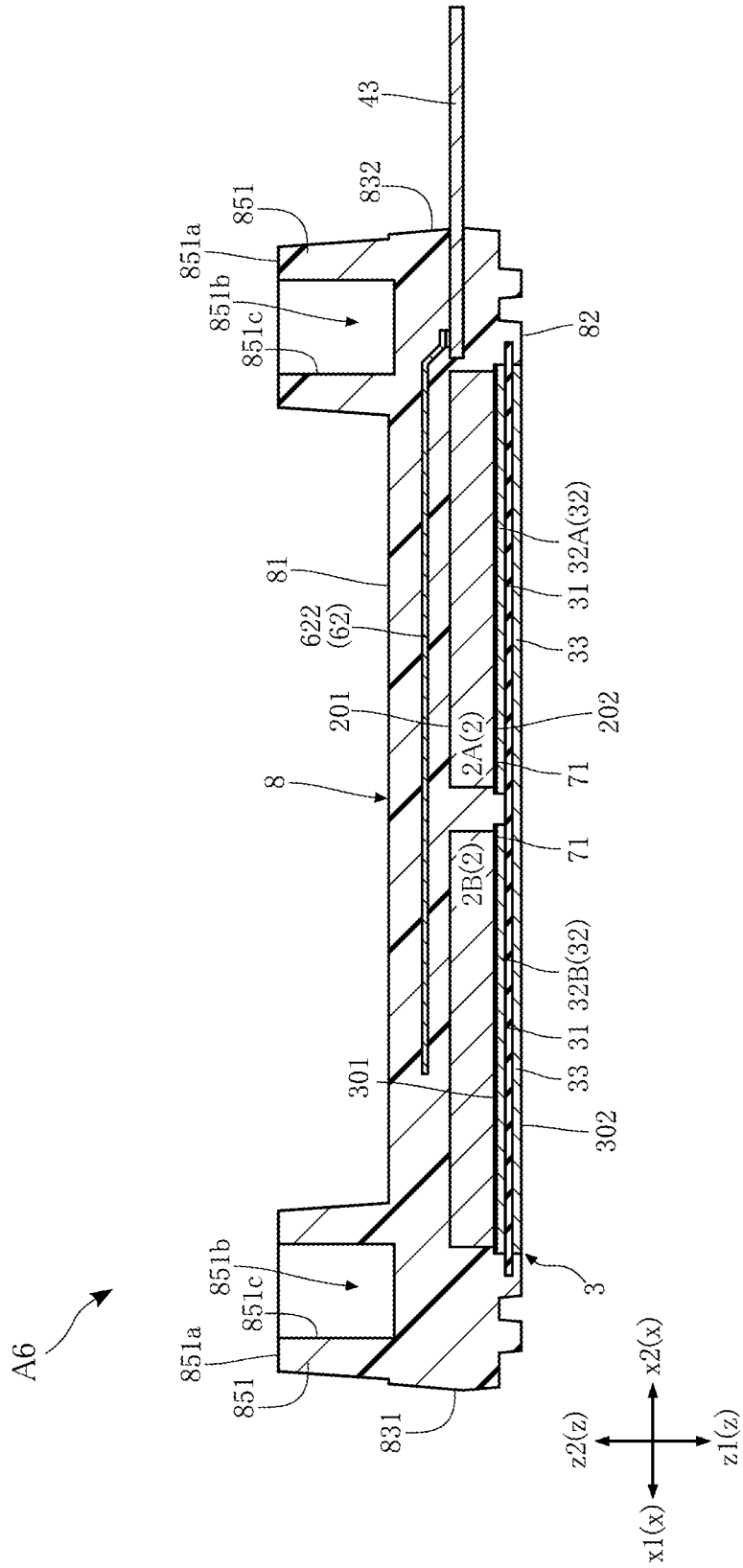

FIG. 42



## SEMICONDUCTOR MODULE

### TECHNICAL FIELD

**[0001]** The present disclosure relates to a semiconductor module.

### BACKGROUND ART

**[0002]** Conventionally, semiconductor modules including power switching elements, such as metal oxide semiconductor field effect transistors (MOSFETs) or insulated gate bipolar transistors (IGBTs), have been known. The semiconductor modules are used in various electronic devices, such as industrial devices, home appliances, information terminals, and automobile devices. Patent Document 1 discloses a conventional semiconductor module (power module). The semiconductor module described in Patent Document 1 includes a semiconductor element and a supporting substrate (ceramic substrate). The semiconductor element is an IGBT made of silicon (Si), for example. The supporting substrate supports the semiconductor element. The supporting substrate includes an insulating base member and conductor layers stacked on the respective surfaces of the base member. The base member is made of ceramic, for example. Each of the conductor layers is made of copper (Cu), for example, and the semiconductor element is bonded to one of the conductor layers.

### PRIOR ART DOCUMENT

#### Patent Document

**[0003]** Patent Document 1: JP-A-2015-220382

### SUMMARY OF THE INVENTION

#### Problem to be Solved by the Invention

**[0004]** In recent years, there has been a demand for energy-saving, sophisticated, and smaller electronic devices. In order to meet the demand, it is necessary to improve the performance and reduce size of semiconductor modules mounted on the electronic devices.

**[0005]** The present disclosure has been conceived in view of the foregoing circumstances, and an object thereof is to provide a semiconductor device having a module configuration preferable for improving performance and size reduction.

#### Means to Solve the Problem

**[0006]** A semiconductor module of the present disclosure includes: a conductive substrate having an obverse surface facing in one sense of a thickness direction, and a reverse surface facing away from the obverse surface in the thickness direction; a semiconductor element electrically bonded to the obverse surface and having a switching function; a control terminal for controlling the semiconductor element; and a sealing resin having a resin obverse surface facing the same side as the obverse surface, and a resin reverse surface facing an opposite side from the resin obverse surface, the sealing resin covering the conductive substrate, the semiconductor element, and a part of the control terminal. The control terminal protrudes from the resin obverse surface, and extends along the thickness direction.

### Advantages of the Invention

**[0007]** According to the configuration as described above, it is possible to provide a semiconductor module configuration preferable for improving performance and size reduction.

### BRIEF DESCRIPTION OF THE DRAWINGS

**[0008]** FIG. 1 is a perspective view illustrating a semiconductor module according to a first embodiment.

**[0009]** FIG. 2 is a perspective view corresponding to FIG. 1 but omitting a sealing resin, a resin member, and a resin-filling portion.

**[0010]** FIG. 3 is a perspective view corresponding to FIG. 2 but omitting a conducting member.

**[0011]** FIG. 4 is a plan view illustrating the semiconductor module according to the first embodiment.

**[0012]** FIG. 5 is a plan view corresponding to FIG. 4 but showing the sealing resin, the resin member, and the resin-filling portion with imaginary lines.

**[0013]** FIG. 6 is a partially enlarged view showing a part of FIG. 5 but omitting the imaginary lines of the sealing resin, the resin member, and the resin-filling portion.

**[0014]** FIG. 7 is a partially enlarged view showing a part of FIG. 6.

**[0015]** FIG. 8 is a plan view corresponding to FIG. 5 but showing a part of the conducting member with an imaginary line.

**[0016]** FIG. 9 is a front view illustrating the semiconductor module according to the first embodiment.

**[0017]** FIG. 10 is a bottom view illustrating the semiconductor module according to the first embodiment.

**[0018]** FIG. 11 is a left side view illustrating the semiconductor module according to the first embodiment.

**[0019]** FIG. 12 is a right side view illustrating the semiconductor module according to the first embodiment.

**[0020]** FIG. 13 is a cross-sectional view taken along line XIII-XIII of FIG. 5.

**[0021]** FIG. 14 is a cross-sectional view taken along line XIV-XIV of FIG. 5.

**[0022]** FIG. 15 is a partially enlarged view showing a part of FIG. 14.

**[0023]** FIG. 16 is a cross-sectional view taken along line XVI-XVI of FIG. 5.

**[0024]** FIG. 17 is a cross-sectional view taken along line XVII-XVII of FIG. 5.

**[0025]** FIG. 18 is a cross-sectional view taken along line XVIII-XVIII of FIG. 5.

**[0026]** FIG. 19 is a cross-sectional view taken along line XIX-XIX of FIG. 5.

**[0027]** FIG. 20 shows an example of the circuit configuration of the semiconductor module according to the first embodiment.

**[0028]** FIG. 21 is a plan view illustrating a step of a method for manufacturing the semiconductor module according to the first embodiment.

**[0029]** FIG. 22 is a schematic cross-sectional view illustrating a step of the method for manufacturing the semiconductor module according to the first embodiment.

**[0030]** FIG. 23 is a plan view illustrating a step of the method for manufacturing the semiconductor module according to the first embodiment.

[0031] FIG. 24 is a cut end view illustrating a step of the manufacturing method according to the first embodiment, and corresponds to the cross-sectional view of FIG. 13.

[0032] FIG. 25 is a partially enlarged cross-sectional view illustrating a step of the method for manufacturing the semiconductor module according to the first embodiment, and corresponds to an enlarged view of a part of the cross-section in FIG. 13.

[0033] FIG. 26 is a partially enlarged cross-sectional view illustrating a step of the method for manufacturing the semiconductor module according to the first embodiment, and corresponds to an enlarged view of a part of the cross-section in FIG. 14.

[0034] FIG. 27 is a partially enlarged cross-sectional view illustrating a step of the method for manufacturing the semiconductor module according to the first embodiment, and corresponds to an enlarged view of a part of the cross-section in FIG. 14.

[0035] FIG. 28 is a partially enlarged cross-sectional view illustrating a step of the method for manufacturing the semiconductor module according to the first embodiment, and corresponds to an enlarged view of a part of the cross-section in FIG. 13.

[0036] FIG. 29 is a partially enlarged cross-sectional view illustrating a step of the method for manufacturing the semiconductor module according to the first embodiment, and corresponds to an enlarged view of a part of the cross-section in FIG. 14.

[0037] FIG. 30 is a front view illustrating a semiconductor module according to a second embodiment.

[0038] FIG. 31 is a right side view illustrating the semiconductor module according to the second embodiment.

[0039] FIG. 32 is a cross-sectional view similar to FIG. 18, and illustrates the semiconductor module according to the second embodiment.

[0040] FIG. 33 is a front view illustrating a semiconductor module according to a third embodiment.

[0041] FIG. 34 is a right side view illustrating the semiconductor module according to the third embodiment.

[0042] FIG. 35 is a cross-sectional view similar to FIG. 18, and illustrates the semiconductor module according to the third embodiment.

[0043] FIG. 36 is a perspective view illustrating a semiconductor module according to a fourth embodiment.

[0044] FIG. 37 is a right side view illustrating the semiconductor module according to the fourth embodiment.

[0045] FIG. 38 is a plan view similar to FIG. 5, and illustrates a semiconductor module according to a fifth embodiment.

[0046] FIG. 39 is a partially enlarged view showing a part of FIG. 38 but omitting the imaginary lines of the sealing resin, the resin member, and the resin-filling portion.

[0047] FIG. 40 is a partially enlarged view showing a part of FIG. 39.

[0048] FIG. 41 is a plan view similar to FIG. 5, and illustrates a semiconductor module according to a sixth embodiment.

[0049] FIG. 42 is a cross-sectional view taken along line XLII-XLII of FIG. 41.

#### MODE FOR CARRYING OUT THE INVENTION

[0050] The following describes preferred embodiments of a semiconductor module according to the present disclosure with reference to the drawings. In the following, the same or

similar elements are provided with the same reference signs, and redundant descriptions are omitted.

[0051] FIGS. 1 to 20 illustrate a semiconductor module A1 according to a first embodiment. The semiconductor module A1 includes a plurality of semiconductor elements 10, a conductive substrate 2, a supporting substrate 3, a plurality of input terminals 41 to 43, a plurality of output terminals 44, a plurality of control terminals 45, a control terminal support 5, a conducting member 6, a first conductive bonding member 71, a second conductive bonding member 72, a plurality of wires 731 to 735, a sealing resin 8, resin members 87, and resin-filling portions 88.

[0052] FIG. 1 is a perspective view illustrating the semiconductor module A1. FIG. 2 is a perspective view corresponding to FIG. 1 but omitting the sealing resin 8, the resin members 87, and the resin-filling portions 88. FIG. 3 is a perspective view corresponding to FIG. 2 but omitting the conducting member 6. FIG. 4 is a plan view illustrating the semiconductor module A1. FIG. 5 is a plan view corresponding to FIG. 4 but showing the sealing resin 8, the resin members 87, and the resin-filling portions 88 with imaginary lines. FIG. 6 is a partially enlarged view showing a part of FIG. 5. In FIG. 6, the imaginary lines of the sealing resin 8, the resin members 87, and the resin-filling portions 88 are omitted. FIG. 7 is a partially enlarged view showing a part of FIG. 6. FIG. 8 is a plan view corresponding to FIG. 5 but showing a part of the conducting member 6 (a second conducting member 62 described below) with an imaginary line. FIG. 9 is a front view illustrating the semiconductor module A1. FIG. 10 is a bottom view illustrating the semiconductor module A1. FIG. 11 is a left side view illustrating the semiconductor module A1. FIG. 12 is a right side view illustrating the semiconductor module A1. FIG. 13 is a cross-sectional view taken along line XIII-XIII of FIG. 5. FIG. 14 is a cross-sectional view taken along line XIV-XIV of FIG. 5. FIG. 15 is a partially enlarged view showing a part of FIG. 14. FIG. 16 is a cross-sectional view taken along line XVI-XVI of FIG. 5. FIG. 17 is a cross-sectional view taken along line XVII-XVII of FIG. 5. FIG. 18 is a cross-sectional view taken along line XVIII-XVIII of FIG. 5. FIG. 19 is a cross-sectional view taken along line XIX-XIX of FIG. 5. In FIGS. 2, 3, 7, 14, and 18, the wires 731 to 735 are omitted. FIG. 20 shows an example of the circuit configuration of the semiconductor module A1. In the circuit diagram of FIG. 20, only one of a plurality of first semiconductor elements 10A (described below) and only one of a plurality of second semiconductor elements 10B (described below) are illustrated, and the rest of the first semiconductor elements 10A and the second semiconductor elements 10B are omitted.

[0053] For convenience, reference is made to three mutually perpendicular directions, i.e., x direction, y direction, and z direction. For example, the z direction corresponds to the thickness direction of the semiconductor module A1. The x direction corresponds to the horizontal direction in the plan view (see FIG. 4) of the semiconductor module A1. The y direction corresponds to the vertical direction in the plan view (see FIG. 4) of the semiconductor module A1. One sense of the x direction is defined as x1 direction, and the other sense as x2 direction. Similarly, one sense of the y direction is defined as y1 direction, and the other sense as y2 direction. One sense of the z direction is defined as z1 direction, and the other sense as z2 direction. In the following description, a “plan view” is a view seen in the z

direction. The z direction is an example of the “thickness direction”, the x direction is an example of a “first direction”, and the y direction is an example of a “second direction”.

**[0054]** The semiconductor elements **10** form the functional core of the semiconductor module **A1**. The semiconductor elements **10** are made of a semiconductor material that mainly contains silicon carbide (SiC), for example. The semiconductor material is not limited to SiC, and may be silicon (Si), gallium arsenide (GaAs) or gallium nitride (GaN). Each of the semiconductor elements **10** has a switching function unit **Q1** (see FIG. **20**) composed of a metal-oxide-semiconductor field-effect transistor (MOSFET), for example. The switching function unit **Q1** is not limited to a MOSFET, and may be another transistor, which is, for example, a field-effect transistor such as a metal-insulator-semiconductor FET or a bipolar transistor such as an IGBT. The semiconductor elements **10** are the same elements. The semiconductor elements **10** are n-channel MOSFETs, for example, but may be p-channel MOSFETs instead.

**[0055]** As shown in FIG. **15**, each of the semiconductor elements **10** has an element obverse surface **101** and an element reverse surface **102**. The element obverse surface **101** and the element reverse surface **102** of each semiconductor element **10** are spaced apart from each other in the z direction. The element obverse surface **101** faces in the z2 direction, and the element reverse surface **102** faces in the z1 direction.

**[0056]** The semiconductor elements **10** include a plurality of first semiconductor elements **10A** and a plurality of second semiconductor elements **10B**. In the present embodiment, the semiconductor module **A1** includes three first semiconductor elements **10A** and three second semiconductor elements **10B**. However, the number of first semiconductor elements **10A** and the number of second semiconductor elements **10B** are not limited thereto, and may be changed as appropriate according to the performance required for the semiconductor module **A1**. In the example shown in FIG. **8**, three first semiconductor elements **10A** and three second semiconductor elements **10B** are provided. The number of first semiconductor elements **10A** and the number of second semiconductor elements **10B** may each be one, two, or no less than four. The number of first semiconductor elements **10A** and the number of second semiconductor elements **10B** may be equal or different. The number of first semiconductor elements **10A** and the number of second semiconductor elements **10B** are determined according to the current capacity handled by the semiconductor module **A1**.

**[0057]** As shown in FIG. **20**, the semiconductor module **A1** may be configured as a half-bridge switching circuit. In this case, the first semiconductor elements **10A** constitute an upper arm circuit of the semiconductor module **A1**, and the second semiconductor elements **10B** constitute a lower arm circuit of the semiconductor module **A1**. In the upper arm circuit, the first semiconductor elements **10A** are connected in parallel to each other, and in the lower arm circuit, the second semiconductor elements **10B** are connected in parallel to each other. Each of the first semiconductor elements **10A** and each of the second semiconductor elements **10B** are connected in series to form a bridge layer.

**[0058]** As shown in FIGS. **8** and **16**, for example, the first semiconductor elements **10A** are mounted on the conductive substrate **2**. In the example shown in FIG. **8**, the first

semiconductor elements **10A** are aligned in the y direction and spaced apart from each other. The first semiconductor elements **10A** are electrically bonded to the conductive substrate **2** (a first conductive portion **2A** described below) via the second conductive bonding member **72**. When the first semiconductor elements **10A** are bonded to the first conductive portion **2A**, the element reverse surfaces **102** face the first conductive portion **2A**.

**[0059]** As shown in FIGS. **8** and **17**, for example, the second semiconductor elements **10B** are mounted on the conductive substrate **2**. In the example shown in FIG. **8**, the second semiconductor elements **10B** are aligned in the y direction and spaced apart from each other. The second semiconductor elements **10B** are electrically bonded to the conductive substrate **2** (a second conductive portion **2B** described below) via the second conductive bonding member **72**. When the second semiconductor elements **10B** are bonded to the second conductive portion **2B**, the element reverse surfaces **102** face the second conductive portion **2B**. As is evident from FIG. **8**, the first semiconductor elements **10A** and the second semiconductor elements **10B** overlap with each other as viewed in the x direction, but they may not necessarily overlap with each other.

**[0060]** Each of the semiconductor elements **10** (the first semiconductor elements **10A** and the second semiconductor elements **10B**) has a first obverse-surface electrode **11**, a second obverse-surface electrode **12**, and a reverse-surface electrode **15**. The configurations of the first obverse-surface electrode **11**, the second obverse-surface electrode **12**, and the reverse-surface electrode **15**, which are described below, are common to each of the semiconductor elements **10**. The first obverse-surface electrode **11** and the second obverse-surface electrode **12** are mounted on the element obverse surface **101**. The first obverse-surface electrode **11** and the second obverse-surface electrode **12** are insulated from each other by an insulating film (not illustrated). The reverse-surface electrode **15** is provided on the element reverse surface **102**.

**[0061]** The first obverse-surface electrode **11** is a gate electrode, for example, to which a drive signal (e.g., gate voltage) for driving the semiconductor element **10** is inputted. In the semiconductor element **10**, the second obverse-surface electrode **12** is a source electrode, for example, through which a source current flows. The reverse-surface electrode **15** is a drain electrode, for example, through which a drain current flows. The reverse-surface electrode **15** almost entirely covers the element reverse surface **102**. The reverse-surface electrode **15** may be formed by Ag plating.

**[0062]** Each of the semiconductor elements **10** switches between a connected state and a disconnected state according to a drive signal (gate voltage), which is input to the first obverse-surface electrode **11** (gate electrode) via the switching function unit **Q1**. The operation of switching between the connected state and the disconnected state is referred to as a switching operation. In the connected state, a current flows from the reverse-surface electrode **15** (drain electrode) to the second obverse-surface electrode **12** (source electrode). In the disconnected state, the current does not flow. In other words, each of the semiconductor elements **10** performs a switching operation through the switching function unit **Q1**. The semiconductor module **A1** converts a first power supply voltage (DC voltage) inputted between the input terminal **41** and the two input terminals **42**, **43** to a second power supply voltage (AC voltage) by the switching

function units Q1 of the semiconductor elements 10, for example, and outputs the second power supply voltage from the output terminals 44. The input terminals 41 to 43 and the output terminals 44 are power supply terminals that handle power supply voltage. The input terminals 41 to 43 are first power supply terminals that receive the first source voltage. The output terminals 44 are second power supply terminals that output the second source voltage.

[0063] Some (two in the example shown in FIG. 8) of the semiconductor elements 10 each have a diode function unit D1 (see FIG. 20) in addition to the switching function unit Q1. In the semiconductor module A1, one of the first semiconductor elements 10A (i.e., the first semiconductor element 10A offset furthest in the y2 direction in FIG. 8) and one of the second semiconductor elements 10B (i.e., the second semiconductor element 10B offset furthest in the y1 direction in FIG. 8) each include a diode function unit D1 in addition to the switching function unit Q1. The function and role of the diode function unit D1 is not particularly limited but one example of the diode function unit D1 is a temperature detection diode. Note that the diode D2 in FIG. 20 is, for example, a parasitic diode component of the switching function unit Q1.

[0064] As shown in FIG. 8, each of the semiconductor elements 10 having the diode function units D1 has a third obverse-surface electrode 13, a fourth obverse-surface electrode 14, and a fifth obverse-surface electrode 16, in addition to the first obverse-surface electrode 11, the second obverse-surface electrode 12, and the reverse-surface electrode 15. The configurations of the third obverse-surface electrode 13, the fourth obverse-surface electrode 14, and the fifth obverse-surface electrode 16, which are described below, are common to each of the semiconductor elements 10 having the diode function units D1. The third obverse-surface electrode 13, the fourth obverse-surface electrode 14, and the fifth obverse-surface electrode 16 are formed on the element obverse surface 101. In each of the semiconductor elements 10 having the diode function units D1, the third obverse-surface electrode 13 and the fourth obverse-surface electrode 14 are electrically connected to the diode function unit D1. The fifth obverse-surface electrode 16 is a source sense electrode, for example, through which a source current in the switching function unit Q1 flows.

[0065] As shown in FIG. 7, each of the first semiconductor elements 10A has a first side 191, a second side 192, a third side 193, and a fourth side 194 in plan view. FIG. 7 illustrates the first semiconductor element 10A arranged in the middle in the y direction among the first semiconductor elements 10A aligned in the y direction, but each of the other first semiconductor elements 10A also similarly has a first side 191, a second side 192, a third side 193, and a fourth side 194. The first side 191 and the second side 192 extend in the y direction. The first side 191 is an edge located in the x2 direction in plan view, and the second side 192 is an edge located in the x1 direction in plan view. The third side 193 and the fourth side 194 extend in the x direction. The third side 193 is an edge located in the y2 direction in plan view, and the fourth side 194 is an edge located in the y1 direction in plan view. Since each of the first semiconductor elements 10A has a rectangular shape in plan view, the four corners formed by the first side 191, the second side 192, the third side 193, and the fourth side 194 are generally right-angled in plan view. As shown in FIG. 7, the four corners do not overlap with the conducting member 6 (first conducting

members 61 and a second conducting member 62 described below) in plan view. The third side 193 and the fourth side 194 are longer than the first side 191 and the second side 192.

[0066] The conductive substrate 2 is also referred to as a lead frame. The conductive substrate 2 supports the semiconductor elements 10. The conductive substrate 2 is bonded to the supporting substrate 3 via the first conductive bonding member 71. The conductive substrate 2 has a rectangular shape in plan view, for example. The conductive substrate 2, together with the conducting member 6, forms the path of a main circuit current switched by the semiconductor elements 10.

[0067] The conductive substrate 2 includes a first conductive portion 2A and a second conductive portion 2B. The first conductive portion 2A and the second conductive portion 2B are plate-like members made of metal. The metal is copper (Cu) or a Cu alloy, for example. The first conductive portion 2A and the second conductive portion 2B form a conductive path to the semiconductor elements 10, together with the input terminals 41 to 43 and the output terminals 44. As shown in FIGS. 13 to 18, the first conductive portion 2A and the second conductive portion 2B are bonded to the supporting substrate 3 via the first conductive bonding member 71. The first semiconductor elements 10A are bonded to the first conductive portion 2A via the second conductive bonding member 72. The second semiconductor elements 10B are bonded to the second conductive portion 2B via the second conductive bonding member 72. As shown in FIGS. 3, 8, 13, and 14, the first conductive portion 2A and the second conductive portion 2B are spaced apart from each other in the x direction. In the example shown in these figures, the first conductive portion 2A is offset in the x2 direction relative to the second conductive portion 2B. The first conductive portion 2A and the second conductive portion 2B each have a rectangular shape in plan view, for example. The first conductive portion 2A and the second conductive portion 2B overlap with each other as viewed in the x direction. The first conductive portion 2A and the second conductive portion 2B may each have a dimension of 15 mm to 25 mm (preferably about 20 mm) in the x direction, a dimension of 30 mm to 40 mm (preferably about 35 mm) in the y direction, and a dimension of 1.5 mm to 3.0 mm (preferably about 2.0 mm) in the z direction.

[0068] The conductive substrate 2 has an obverse surface 201 and a reverse surface 202. As shown in FIGS. 13, 14, and 16 to 18, the obverse surface 201 and the reverse surface 202 are spaced apart from each other in the z direction. The obverse surface 201 faces in the z2 direction, and the reverse surface 202 faces in the z1 direction. The obverse surface 201 is a combination of the upper surface of the first conductive portion 2A and the upper surface of the second conductive portion 2B. The reverse surface 202 is a combination of the lower surface of the first conductive portion 2A and the lower surface of the second conductive portion 2B. The reverse surface 202 faces the supporting substrate 3 and is bonded to the supporting substrate 3. As shown in FIGS. 5, 8, and 13, the obverse surface 201 is formed with a plurality of recessed portions 201a. The recessed portions 201a are recessed from the obverse surface 201 in the z direction. The degree of recession (depth) of each recessed portion 201a is greater than 0  $\mu\text{m}$  and less than or equal to 100  $\mu\text{m}$ , for example. The recessed portions 201a are formed during molding described below, for example. The recessed

portions **201a** include those formed in the obverse surface **201** of the first conductive portion **2A**, and those formed in the obverse surface **201** of the second conductive portion **2B**. Two recessed portions **201a** formed in the obverse surface **201** of the first conductive portion **2A** are spaced apart from each other in the y direction and overlap with each other as viewed in the y direction. Two recessed portions **201a** formed in the obverse surface **201** of the second conductive portion **2B** are spaced apart from each other in the y direction and overlap with each other as viewed in the y direction.

[0069] The conductive substrate **2** (each of the first conductive portion **2A** and the second conductive portion **2B**) includes a base member **21**, an obverse-surface bonding layer **22**, and a reverse-surface bonding layer **23** that are stacked on each other. The base member **21** is a plate-like member made of metal. The metal is Cu or a Cu alloy. The obverse-surface bonding layer **22** is formed on the upper surface of the base member **21**. The obverse-surface bonding layer **22** is the surface layer of the conductive substrate **2** in the z2 direction. The upper surface of the obverse-surface bonding layer **22** corresponds to the obverse surface **201** of the conductive substrate **2**. The obverse-surface bonding layer **22** is a Ag plating layer, for example. The reverse-surface bonding layer **23** is formed on the lower surface of the base member **21**. The reverse-surface bonding layer **23** is the surface layer of the conductive substrate **2** in the z1 direction. The lower surface of the reverse-surface bonding layer **23** corresponds to the reverse surface **202** of the conductive substrate **2**. The reverse-surface bonding layer **23** is a Ag plating layer, for example, as is the obverse-surface bonding layer **22**.

[0070] The supporting substrate **3** supports the conductive substrate **2**. The supporting substrate **3** is a direct bonded copper (DBC) substrate, for example. The supporting substrate **3** includes an insulating layer **31**, a first metal layer **32**, a first bonding layer **321**, and a second metal layer **33**.

[0071] The insulating layer **31** is made of a ceramic with excellent thermal conductivity, for example. The ceramic may be aluminum nitride (AlN). The insulating layer **31** is not limited to a ceramic, and may be an insulating resin sheet, for example. The insulating layer **31** has a rectangular shape in plan view, for example.

[0072] The first metal layer **32** is formed on the upper surface (surface facing in the z2 direction) of the insulating layer **31**. The material of the first metal layer **32** contains Cu, for example. The material may contain Al instead of Cu. The first metal layer **32** includes a first portion **32A** and a second portion **32B**. The first portion **32A** and the second portion **32B** are spaced apart from each other in the x direction. The first portion **32A** is offset in the x2 direction relative to the second portion **32B**. The first portion **32A** is bonded to the first conductive portion **2A** and supports the first conductive portion **2A**. The second portion **32B** is bonded to the second conductive portion **2B** and supports the second conductive portion **2B**. The first portion **32A** and the second portion **32B** each have a rectangular shape in plan view, for example.

[0073] The first bonding layer **321** is formed on the upper surface of the first metal layer **32** (each of the first portion **32A** and the second portion **32B**). The first bonding layer **321** is a Ag plating layer, for example. The first bonding layer **321** is provided to enhance the solid-phase diffusion bonding with the first conductive bonding member **71**.

[0074] The second metal layer **33** is formed on the lower surface of the insulating layer **31** (surface facing in the z1 direction). The second metal layer **33** is made of the same material as the first metal layer **32**. In the example shown in FIG. 10, the lower surface (a bottom surface **302** described below) of the second metal layer **33** is exposed from the sealing resin **8**. The lower surface may not be exposed from the sealing resin **8**, and may be covered with the sealing resin **8**. The second metal layer **33** may overlap with the first portion **32A** and the second portion **32B** in plan view.

[0075] As shown in FIGS. 13 to 18, the supporting substrate **3** has a supporting surface **301** and a bottom surface **302**. The supporting surface **301** and the bottom surface **302** are spaced apart from each other in the z direction. The supporting surface **301** faces in the z2 direction, and the bottom surface **302** faces in the z1 direction. As shown in FIG. 10, the bottom surface **302** is exposed from the sealing resin **8**. The supporting surface **301** is the upper surface of the first bonding layer **321**, i.e., a combination of the upper surface of the first portion **32A** and the upper surface of the second portion **32B**. The supporting surface **301** faces the conductive substrate **2**, and is bonded to the conductive substrate **2**. The bottom surface **302** is the lower surface of the second metal layer **33**. A heat dissipating member (e.g., heat sink) or the like, which is not illustrated in the figure, can be attached to the bottom surface **302**. The dimension of the supporting substrate **3** in the z direction (distance along the z direction from the supporting surface **301** to the bottom surface **302**) is 0.7 mm to 2.0 mm, for example.

[0076] Each of the input terminals **41** to **43** and the output terminals **44** is a plate-like metal plate. The metal plate is made of Cu or a Cu alloy, for example. In the example shown in FIGS. 1 to 5, 8, and 10, the semiconductor module **A1** includes the three input terminals **41** to **43** and the two output terminals **44**.

[0077] Power supply voltage is applied to the three input terminals **41** to **43**. In the present embodiment, the input terminal **41** is a positive electrode (P terminal), and the two input terminals **42** and **43** are negative electrodes (N terminal). Alternatively, the input terminal **41** may be a negative terminal (N terminal), and the two input terminals **42** and **43** may be positive terminals (P terminals). In this case, the wiring in the package may be appropriately changed according to the change in the polarity of each terminal. Each of the three input terminals **41** to **43** and the two output terminals **44** includes a portion covered with the sealing resin **8** and a portion exposed from a resin side surface of the sealing resin **8**.

[0078] As shown in FIG. 14, the input terminal **41** is formed integrally with the first conductive portion **2A**. Unlike this configuration, the input terminal **41** may be separated from the first conductive portion **2A** and electrically bonded to the first conductive portion **2A**. As shown in FIG. 8, for example, the input terminal **41** is offset in the x2 direction relative to the first semiconductor elements **10A** and the first conductive portion **2A** (conductive substrate **2**). The input terminal **41** is electrically connected to the first conductive portion **2A**, and is electrically connected to the reverse-surface electrodes **15** (drain electrodes) of the first semiconductor elements **10A** via the first conductive portion **2A**. The input terminal **41** is an example of a “first input terminal”.

[0079] The input terminal **41** has an input-side bonding surface **411** and input-side side surfaces **412**. The input-side

bonding surface 411 faces in the z2 direction and extends in the x2 direction. Each of the input-side side surfaces 412 is located at the periphery of the input-side bonding surface 411 as viewed in the z direction, and faces in a direction intersecting with the input-side bonding surface 411. In the present embodiment, the input-side side surfaces 412 include a tip surface 413 and a pair of lateral surfaces 414. The tip surface 413 is positioned at the end of the input terminal 41 in the x2 direction and faces in the x2 direction. The pair of lateral surfaces 414 are located at the respective ends of the input terminal 41 in the y direction, and face in the y1 direction and the y2 direction, respectively. Among the input-side side surfaces 412, at least one of the tip surface 413 and the pair of lateral surfaces 414 has an input-side machining mark. The input-side machining mark is formed by the cutting process of a lead frame as described below.

[0080] As shown in FIG. 8, the two input terminals 42 and 43 are spaced apart from the first conductive portion 2A. The two input terminals 42 and 43 are bonded to the second conducting member 62. As shown in FIG. 8, for example, the two input terminals 42 and 43 are offset in the x2 direction relative to the first semiconductor elements 10A and the first conductive portion 2A (conductive substrate 2). The two input terminals 42 and 43 are electrically connected to the second conducting member 62, and are electrically connected to the second obverse-surface electrodes 12 (source electrodes) of the second semiconductor elements 10B via the second conducting member 62. The input terminal 42 is an example of a “second input terminal”, and the input terminal 43 is an example of a “third input terminal”.

[0081] The input terminal 42 has an input-side bonding surface 421 and input-side side surfaces 422, and the input terminal 43 has an input-side bonding surface 431 and input-side side surfaces 432. The input-side bonding surfaces 421 and 431 face in the z2 direction, and extend in the x2 direction. Each of the input-side side surfaces 422 is located at the periphery of the input-side bonding surface 421 as viewed in the z direction, and faces in a direction intersecting with the input-side bonding surface 421. Each of the input-side side surfaces 432 is located at the periphery of the input-side bonding surface 431 as viewed in the z direction, and faces in a direction intersecting with the input-side bonding surface 431. In the present embodiment, the input-side side surfaces 422 include a tip surface 423 and a pair of lateral surfaces 424. The tip surface 423 is positioned at the end of the input terminal 42 in the x2 direction and faces in the x2 direction. The pair of lateral surfaces 424 are located at the respective ends of the input terminal 42 in the y direction, and face in the y1 direction and the y2 direction, respectively. Among the input-side side surfaces 422, at least one of the tip surface 423 and the pair of lateral surfaces 424 has an input-side machining mark. The input-side machining mark is formed by the cutting process of a lead frame as described below. The input-side side surfaces 432 include a tip surface 433 and a pair of lateral surfaces 434. The tip surface 433 is positioned at the end of the input terminal 43 in the x2 direction and faces in the x2 direction. The pair of lateral surfaces 434 are located at the respective ends of the input terminal 43 in the y direction, and face in the y1 direction and the y2 direction, respectively. Among the input-side side surfaces 432, at least one of the tip surface 433 and the pair of lateral surfaces 434 has an

input-side machining mark. The input-side machining mark is formed by the cutting process of a lead frame as described below.

[0082] As shown in FIGS. 1 to 5, 8, and 10, for example, the three input terminals 41 to 43 of the semiconductor module A1 protrude from the sealing resin 8 in the x2 direction. The three input terminals 41 to 43 are spaced apart from each other. The two input terminals 42 and 43 are located opposite from each other with the input terminal 41 therebetween in the y direction. The input terminal 42 is offset in the y2 direction relative to the input terminal 41, and the input terminal 43 is offset in the y1 direction relative to the input terminal 41. The three input terminals 41 to 43 overlap with each other as viewed in the y direction.

[0083] As is evident from FIGS. 8 and 14, the two output terminals 44 are integrally formed with the second conductive portion 2B. Unlike this configuration, the output terminals 44 may be separated from the second conductive portion 2B and electrically bonded to the second conductive portion 2B. As shown in FIG. 8, for example, the two output terminals 44 are offset in the x1 direction relative to the second semiconductor elements 10B and the second conductive portion 2B (conductive substrate 2). The output terminals 44 are electrically connected to the second conductive portion 2B, and are electrically connected to the reverse-surface electrodes 15 (drain electrodes) of the second semiconductor elements 10B via the second conductive portion 2B. The two output terminals 44 are examples of a “first output terminal” and a “second output terminal”.

[0084] Each of the output terminals 44 has an output-side bonding surface 441 and output-side side surfaces 442. The output-side bonding surface 441 faces in the z2 direction and extends in the x1 direction. Each of the output-side side surfaces 442 is located at the periphery of the output-side bonding surface 441 as viewed in the z direction, and faces in a direction intersecting with the output-side bonding surface 441. In the present embodiment, the output-side side surfaces 442 include a tip surface 443 and a pair of lateral surfaces 444. The tip surface 443 is positioned at the end of the output terminal 44 in the x1 direction and faces in the x1 direction. The pair of lateral surfaces 444 are located at the respective ends of the output terminal 44 in the y direction, and face in the y1 direction and the y2 direction, respectively. Among the output-side side surfaces 442, at least one of the tip surface 443 and the pair of lateral surfaces 444 has an output-side machining mark. The output-side machining mark is formed by the cutting process of a lead frame as described below. The number of output terminals 44 is not limited to two, and may be one or no less than three. When the number of output terminals 44 is one, it is desirable that the output terminal 44 be connected to the middle section of the second conductive portion 2B in the y direction.

[0085] The control terminals 45 are pin-like terminals for controlling the semiconductor elements 10. The control terminals 45 include a plurality of first control terminals 46A to 46E and a plurality of second control terminals 47A to 47D. The first control terminals 46A to 46E are used to control the first semiconductor elements 10A. The second control terminals 47A to 47D are used to control the second semiconductor elements 10B.

[0086] The first control terminals 46A to 46E are arranged at intervals in the y direction. As shown in FIGS. 8 and 14, for example, the first control terminals 46A to 46E are supported by the first conductive portion 2A via the control

terminal support **5** (a first supporting portion **5A** described below). As shown in FIGS. **5** and **8**, the first control terminals **46A** to **46E** are located between the first semiconductor elements **10A** and the three input terminals **41** to **43** in the x direction.

[0087] The first control terminal **46A** is a terminal (gate terminal) used to input a drive signal for the first semiconductor elements **10A**. The first control terminal **46A** receives the drive signal for driving the first semiconductor elements **10A** (e.g., it receives application of gate voltage).

[0088] The first control terminal **46B** is a terminal (source sense terminal) used to detect a source signal for the first semiconductor elements **10A**. Voltage (corresponding to a source current) applied to the second obverse-surface electrodes **12** (source electrodes) of the first semiconductor elements **10A** is detected from the first control terminal **46B**.

[0089] The first control terminals **46C** and **46D** are terminals that are electrically connected to the diode function unit **D1**. The first control terminal **46C** is electrically connected to the third obverse-surface electrode **13** of the first semiconductor element **10A** having the diode function unit **D1**, and the first control terminal **46D** is electrically connected to the fourth obverse-surface electrode **14** of the first semiconductor element **10A** having the diode function unit **D1**.

[0090] The first control terminal **46E** is a terminal (drain sense terminal) used to detect a drain signal for the first semiconductor elements **10A**. Voltage (corresponding to a drain current) applied to the reverse-surface electrodes **15** (drain electrodes) of the first semiconductor elements **10A** is detected from the first control terminal **46E**.

[0091] The second control terminals **47A** to **47D** are arranged at intervals in the y direction. As shown in FIGS. **5** and **18**, for example, the second control terminals **47A** to **47D** are supported by the second conductive portion **2B** via the control terminal support **5** (a second supporting portion **5B** described below). As shown in FIGS. **5** and **8**, the second control terminals **47A** to **47D** are located between the second semiconductor elements **10B** and the two output terminals **44** in the x direction.

[0092] Each of the control terminals **45** (first control terminals **46A** to **46E** and the second control terminals **47A** to **47D**) includes a holder **451** and a metal pin **452**.

[0093] The holder **451** is made of a conductive material. As shown in FIG. **15**, the holder **451** is bonded to the control terminal support **5** (a first metal layer **52** described below) via a conductive bonding member **459**. The holder **451** includes a tubular portion, an upper-end flange portion, and a lower-end flange portion. The upper-end flange portion is joined to the top of the tubular portion, and the lower-end flange portion is joined to the bottom of the tubular portion. The metal pin **452** is inserted through at least the upper-end flange portion and the tubular portion of the holder **451**. The upper surface of the upper-end flange portion is exposed from the sealing resin **8** (a second protruding portion **852** described below), and is covered with the resin member **87**.

[0094] The metal pin **452** is a rod-like member extending in the z direction. The metal pin **452** is supported by being pressed into the holder **451**. The metal pin **452** is electrically connected to the control terminal support **5** (a first metal layer **52** described below) at least via the holder **451**. As shown in the example in FIG. **15**, when the lower end (end in the z1 direction) of the metal pin **452** is in contact with the conductive bonding member **459** within the insertion hole of

the holder **451**, the metal pin **452** is electrically connected to the control terminal support **5** via the conductive bonding member **459**.

[0095] The control terminal support **5** supports the control terminals **45**. The control terminal support **5** is provided between the obverse surface **201** (conductive substrate **2**) and the control terminals **45**.

[0096] The control terminal support **5** includes a first supporting portion **5A** and a second supporting portion **5B**. The first supporting portion **5A** is arranged on the first conductive portion **2A** of the conductive substrate **2**, and supports the first control terminals **46A** to **46E** among the control terminals **45**. As shown in FIG. **15**, the first supporting portion **5A** is bonded to the first conductive portion **2A** via a bonding member **59**. The bonding member **59** may be conductive or insulative. For example, the bonding member **59** may be solder. The second supporting portion **5B** is arranged on the second conductive portion **2B** of the conductive substrate **2**, and supports the second control terminals **47A** to **47D** among the control terminals **45**. The second supporting portion **5B** is bonded to the second conductive portion **2B** via the bonding member **59**.

[0097] The control terminal support **5** (the first supporting portion **5A** and the second supporting portion **5B**) may be a DBC substrate, for example. Each of the supporting portions of the control terminal support **5** includes an insulating layer **51**, a first metal layer **52**, and a second metal layer **53** that are stacked on each other.

[0098] The insulating layer **51** is made of a ceramic, for example. The insulating layer **51** has a rectangular shape in plan view, for example.

[0099] As shown in FIG. **15**, for example, the first metal layer **52** is formed on the upper surface of the insulating layer **51**. The control terminals **45** are erected on the first metal layer **52**. The first metal layer **52** is made of Cu or a Cu alloy, for example. As shown in FIG. **8**, the first metal layer **52** includes a first portion **521**, a second portion **522**, a third portion **523**, a fourth portion **524**, and a fifth portion **525**. The first portion **521**, the second portion **522**, the third portion **523**, the fourth portion **524**, and the fifth portion **525** are spaced apart and insulated from each other.

[0100] A plurality of wires **731** are bonded to the first portion **521**, so that the first portion **521** is electrically connected to the first obverse-surface electrodes **11** (gate electrodes) of the semiconductor elements **10** via the wires **731**. As shown in FIG. **8**, the first control terminal **46A** is bonded to the first portion **521** of the first supporting portion **5A**, and the second control terminal **47A** is bonded to the first portion **521** of the second supporting portion **5B**.

[0101] A plurality of wires **732** are bonded to the second portion **522**, so that the second portion **522** is electrically connected to the second obverse-surface electrodes **12** (source electrodes) of the semiconductor elements **10** via the wires **732**. As shown in FIG. **8**, the first control terminal **46B** is bonded to the second portion **522** of the first supporting portion **5A**, and the second control terminal **47B** is bonded to the second portion **522** of the second supporting portion **5B**.

[0102] A wire **733** is bonded to the third portion **523**, so that the third portion **523** is electrically connected to the third obverse-surface electrode **13** of the semiconductor element **10** having the diode function unit **D1** via the wire **733**. As shown in FIG. **8**, the first control terminal **46C** is bonded to the third portion **523** of the first supporting portion

5A, and the second control terminal 47C is bonded to the third portion 523 of the second supporting portion 5B.

[0103] A wire 734 is bonded to the fourth portion 524, so that the fourth portion 524 is electrically connected to the fourth obverse-surface electrode 14 of the semiconductor element 10 having the diode function unit D1 via the wire 734. As shown in FIG. 8, the first control terminal 46D is bonded to the fourth portion 524 of the first supporting portion 5A, and the second control terminal 47D is bonded to the fourth portion 524 of the second supporting portion 5B.

[0104] A wire 735 is bonded to the fifth portion 525 of the first supporting portion 5A, and the fifth portion 525 is electrically connected to the first conductive portion 2A. The fifth portion 525 of the second supporting portion 5B is not electrically connected to other components. As shown in FIG. 8, the first control terminal 46E is bonded to the fifth portion 525 of the first supporting portion 5A.

[0105] As shown in FIG. 15, for example, the second metal layer 53 is formed on the lower surface of the insulating layer 51. As shown in FIG. 15, the second metal layer 53 of the first supporting portion 5A is bonded to the first conductive portion 2A via the bonding member 59. The second metal layer 53 of the second supporting portion 5B is bonded to the second conductive portion 2B via the bonding member 59.

[0106] The conducting member 6, together with the conductive substrate 2, forms the path of a main circuit current switched by the semiconductor elements 10. The conducting member 6 is separated from the obverse surface 201 (conductive substrate 2) in the z2 direction, and overlaps with the obverse surface 201 in plan view. In the present embodiment, the conducting member 6 is made of a metal plate-like member. The metal is Cu or a Cu alloy, for example. Specifically, the conducting member 6 is a metal plate-like member that is bent. Alternatively, the conducting member 6 may be formed with a metal foil member. In the present embodiment, the conducting member 6 includes a plurality of first conducting members 61 and a second conducting member 62. The main circuit current includes a first main circuit current and a second main circuit current. The first main circuit current flows through a path between the input terminal 41 and the output terminals 44. The second main circuit current flows through a path between the output terminals 44 and the input terminals 42, 43.

[0107] The first conducting members 61 are connected to the second obverse-surface electrodes 12 (source electrodes) of the first semiconductor elements 10A and the second conductive portion 2B, so that the second obverse-surface electrodes 12 of the first semiconductor elements 10A are electrically connected to the second conductive portion 2B. The first conducting members 61 and the second obverse-surface electrodes 12 (see FIG. 8) of the first semiconductor elements 10A, as well as the first conducting members 61 and the second conductive portion 2B, are bonded to each other via the conductive bonding member 69. The conductive bonding member 69 may be made of solder, a metal paste material, or a sintered metal. As shown in FIG. 8, each of the first conducting members 61 has a band shape extending along the x direction in plan view.

[0108] In the present embodiment, each of the first conducting members 61 has a rectangular portion connecting the first semiconductor element 10A and the second conductive portion 2B, and the rectangular portion is formed

with an opening 61h, as shown in FIG. 6, for example. The opening 61h may be a through-hole that penetrates through in the z direction, and is preferably formed in the center of the rectangular portion in plan view. The opening 61h is formed so that when a flowable resin material is injected to form a sealing resin, the resin material can easily flow between the upper side (in the z2 direction) and the lower side (in the z1 direction) near the first conducting member 61. In plan view, the opening 61h may have a perfectly circular shape, or may have another shape such as an oval shape or a rectangular shape. Each of the first conducting members 61 is not limited to having the configuration described above, and may not be formed with an opening 61h.

[0109] In the present embodiment, the number of first conducting members 61 is three so as to correspond to the number of first semiconductor elements 10A. Alternatively, a single first conducting member 61 common to the first semiconductor elements 10A may be used, without depending on the number of first semiconductor elements 10A.

[0110] The second conducting member 62 electrically connects the second obverse-surface electrodes 12 of the second semiconductor elements 10B to the input terminals 42 and 43. The second conducting member 62 may have a maximum dimension of 25 mm to 40 mm (preferably about 32 mm) in the x direction, and a maximum dimension of 30 mm to 45 mm (preferably about 38 mm) in the y direction. As shown in FIG. 6, the second conducting member 62 includes a first wiring portion 621, a second wiring portion 622, a third wiring portion 623, and a fourth wiring portion 624.

[0111] The first wiring portion 621 is connected to the input terminal 42. The first wiring portion 621 and the input terminal 42 are bonded with the conductive bonding member 69. The first wiring portion 621 has a band shape extending in the x direction in plan view.

[0112] The second wiring portion 622 is connected to the input terminal 43. The second wiring portion 622 and the input terminal 43 are bonded with the conductive bonding member 69. The second wiring portion 622 has a band shape extending in the x direction in plan view. The first wiring portion 621 and the second wiring portion 622 are spaced apart from each other in the y direction and arranged substantially in parallel to each other. The second wiring portion 622 is offset in the y1 direction relative to the first wiring portion 621.

[0113] The third wiring portion 623 is joined to the first wiring portion 621 and the second wiring portion 622. The third wiring portion 623 has a band shape extending in the y direction in plan view. As is evident from FIG. 6, the third wiring portion 623 overlaps with the second semiconductor elements 10B in plan view. As shown in FIG. 17, the third wiring portion 623 is connected to the second semiconductor elements 10B. The third wiring portion 623 has a plurality of recessed areas 623a. As shown in FIG. 17, the recessed areas 623a are recessed in the z1 direction relative to the other areas of the third wiring portion 623. The recessed areas 623a of the third wiring portion 623 are bonded to the second semiconductor elements 10B. The recessed areas 623a of the third wiring portion 623 and the second obverse-surface electrodes 12 (see FIG. 8) of the second semiconductor elements 10B are bonded with the conductive bonding member 69.

[0114] The fourth wiring portion **624** is joined to the first wiring portion **621** and the second wiring portion **622**. The fourth wiring portion **624** is also connected to the third wiring portion **623**. The fourth wiring portion **624** is offset in the x2 direction relative to the third wiring portion **623**. As is evident from FIG. 6, the fourth wiring portion **624** overlaps with the first semiconductor elements **10A** in plan view. The fourth wiring portion **624** includes a first band portion **625** and a plurality of second band portions **626**.

[0115] The first band portion **625** is a part of the fourth wiring portion **624** that has a band shape in plan view, and is spaced apart from the third wiring portion **623** in the x direction. The first band portion **625** is joined to the first wiring portion **621** and the second wiring portion **622**. The first band portion **625** overlaps with the first semiconductor elements **10A** in plan view. The first band portion **625** has a plurality of protruding areas **625a**. As shown in FIG. 16, the protruding areas **625a** protrude in the z2 direction relative to the other areas of the first band portion **625**. As shown in FIG. 6, the protruding areas **625a** overlap with the first semiconductor elements **10A** in plan view. Since the first band portion **625** has the protruding areas **625a**, areas for bonding the first conducting members **61** are provided on the first semiconductor elements **10A**, as shown in FIG. 16. This prevents the first band portion **625** from being in contact with the first conducting members **61**.

[0116] Each of the second band portions **626** is connected to the first band portion **625** and the third wiring portion **623**. Each of the second band portions **626** has a band shape extending in the x direction in plan view. The second band portions **626** are spaced apart from each other in the y direction and arranged substantially in parallel to each other. In plan view, one end of each band portion **626** is connected to a part of the first band portion **625**, which is located between two first semiconductor elements **10A** adjacent in the y direction, and the other end of each band portion **626** is connected to a part of the third wiring portion **623**, which is located between two second semiconductor elements **10B** adjacent in the y direction.

[0117] The first band portion **625** has a first edge **627** and a second edge **628**. As shown in FIG. 7, the first edge **627** is offset in the x1 direction relative to the first side **191** in plan view, and extends at least from the third side **193** to the fourth side **194** in the y direction. As such, two corners **171** and **172** of each first semiconductor element **10A** in the x2 direction do not overlap with the second conducting member **62** in plan view. The two corners are the corner **171** formed by the first side **191** and the third side **193**, and the corner **172** formed by the first side **191** and the fourth side **194**. Accordingly, in each of the first semiconductor elements **10A**, parts of the two sides flanking the corners **171** and **172** are visible in plan view (specifically, when viewed as shown in FIG. 7; the same applies hereinafter). As shown in FIG. 7, the second edge **628** is offset in the x2 direction relative to the second side **192** in plan view, and extends at least from the third side **193** to the fourth side **194** in the y direction. As such, two corners **173** and **174** of each first semiconductor element **10A** in the x1 direction do not overlap with the second conducting member **62** in plan view. The two corners are the corner **173** formed by the second side **192** and the third side **193**, and the corner **174** formed by the second side **192** and the fourth side **194**. Accordingly, in

each of the first semiconductor elements **10A**, parts of the two sides flanking the corners **173** and **174** are visible in plan view.

[0118] Regarding the corners **171**, **172**, **173**, and **174**, it is sufficient for each of the visible portions of the two sides flanking the corners **171**, **172**, **173**, and **174** to have a length greater than 0  $\mu\text{m}$  and no greater than 200  $\mu\text{m}$  in plan view. Furthermore, it is preferable that in plan view, the length of each of the visible portions of the two sides flanking the corners **171**, **172**, **173**, and **174** be no less than 5  $\mu\text{m}$  and no greater than 150  $\mu\text{m}$ . When the length of each of the visible portions of the two sides flanking the corners **171**, **172**, **173**, and **174** is no less than 2  $\mu\text{m}$ , it is possible to detect the corners of each of the first semiconductor elements **10A**. When the length of each of the visible portions of the two sides is no less than 5  $\mu\text{m}$ , it is possible to reliably detect the corners of each of the first semiconductor elements **10A**. When the length of each of the visible portions of the two sides is greater than 200  $\mu\text{m}$ , the bonding areas between the first conducting members **61** and the first semiconductor elements **10A** become smaller than necessary, which is not desirable. It is preferable that the upper limit of the length of each of the visible portions of the two sides be no greater than 150  $\mu\text{m}$ , because the bonding area between the first conducting members **61** and the first semiconductor elements **10A** is prevented from being too small.

[0119] As shown in FIG. 6, the conducting member **6** (first conducting members **61** and the second conducting member **62**) has first portions **601**. The first portions **601** are areas that overlap with the semiconductor elements **10** (the first semiconductor elements **10A** and the second semiconductor elements **10B**) in plan view. At the second conducting member **62**, parts of the fourth wiring portion **624** (areas overlapping with the first semiconductor elements **10A** in plan view) and parts of the third wiring portion **623** (areas overlapping with the second semiconductor elements **10B** in plan view) constitute the first portions **601**.

[0120] As shown in FIGS. 6 and 8, the obverse-surface electrodes **11**, **13**, **14**, and **16** of one of the first semiconductor elements **10A** (the first semiconductor element **10A** having the diode function unit **D1**) are aligned along the y direction at the end of the first semiconductor element **10A** in the x2 direction. In plan view, the first conducting members **61** and the second conducting member **62** do not overlap with the obverse-surface electrodes **11**, **13**, **14**, and **16** of the first semiconductor element **10A** or with the corners **171** and **172** thereof in the x2 direction. Furthermore, in plan view, the first conducting members **61** and the second conducting member **62** do not overlap with at least one of the corners **173** and **174** of the first semiconductor element **10A** in the x1 direction (opposite from the side where the obverse-surface electrodes are arranged). As such, at least three corners among the four corners **171**, **172**, **173**, and **174** of the semiconductor element **10A** are visible in plan view. This makes it possible to inspect whether the first semiconductor elements **10A** are correctly mounted by automatic visual inspection when the first semiconductor elements **10A**, the conducting members **61**, and the second conducting member **62** are mounted on the conductive substrate **2**. In plan view, the four corners **171**, **172**, **173**, and **174** of each of the first semiconductor elements **10A** may all be visible. Note that the obverse-surface electrodes **11**, **13**, **14**, and **16** of the first semiconductor element **10A** are examples of "obverse-surface electrodes on one side".

[0121] As shown in FIG. 6, each of the second semiconductor elements 10B has a rectangular shape in plan view, similarly to the first semiconductor elements 10A, and has four corners 181, 182, 183, and 184 corresponding to the four corners 171, 172, 173, and 174 of each first semiconductor element 10A. The above-described relationship in plan view between the four corners 171, 172, 173, and 174 of each first semiconductor element 10A and the first and second conducting members 61, 62 also holds for the relationship in plan view between the four corners 181, 182, 183, and 184 of each second semiconductor element 10B and the second conducting member 62.

[0122] As shown in FIG. 5, the second conducting member 62 includes first portions 62A and second portions 62B. The first portions 62A overlap with the obverse surface 201 of the conductive substrate 2 (the obverse surface 201 of either the first conductive portion 2A or the second conductive portion 2B) in plan view, and do not overlap with any of the semiconductor elements 10 in plan view. The second portions 62B overlap with the obverse surface 201 in plan view, and overlap with the semiconductor elements 10 in plan view. In FIG. 5, the first portions 62A are shown with hatching that diagonally rising to the right, and the second portions 62B are shown with hatching that diagonally falling to the right. The first portions 62A have openings 63. As shown in FIGS. 5 and 13, for example, the openings 63 are partially cut away portions in plan view. In the present embodiment, the openings 63 are provided at positions that overlap with the obverse surface 201 of the first conductive portion 2A (conductive substrate 2) in plan view, and that do not overlap with the semiconductor elements 10 in plan view. The openings 63 are through-holes that penetrate through in the z direction, for example. The openings 63 include one formed in the first wiring portion 621 and one formed in the second wiring portion 622. The openings 63 are provided in the vicinity of at least two of the four corners of the conductive substrate 2 in plan view. For example, one of the openings 63 is provided at an area of the first wiring portion 621 in the x2 direction, and the other at an area of the second wiring portion 622 in the x2 direction. Note that the planar shape of each opening 63 is not limited. For example, the openings 63 may be holes as described in the present embodiment or notches unlike the present embodiment. The openings 63 may be formed by electroforming, for example. In this case, the second conducting member 62 has openings 63 in areas not electrodeposited with a metal, instead of the openings 63 formed by removing portions of the second conducting member 62.

[0123] The second conducting member 62 is formed with openings 625h in rectangular portions that overlap with the first semiconductor elements 10A in plan view. In the present embodiment, it is preferable that the openings 625h be formed to overlap with the centers of the first semiconductor elements 10A in plan view. The openings 625h are through-holes (see FIG. 6) formed in the protruding areas 625a of the first band portion 625 (fourth wiring portion 624), for example. The openings 625h are used, when the first conducting members 61 and the first semiconductor elements 10A are bonded, to optically check the bonding state from above.

[0124] The second conducting member 62 is formed with openings 623h in rectangular portions that overlap with the second semiconductor elements 10B in plan view. In the present embodiment, it is preferable that the openings 623h

be formed to overlap with the centers of the second semiconductor elements 10B in plan view. The openings 623h are through-holes formed in the recessed areas 623a of the third wiring portion 623, for example. The openings 623h are used when the second conducting member 62 is positioned relative to the conductive substrate 2. In plan view, each of the two types of openings 623h and 625h may have a perfectly circular shape, or may have another shape such as an oval shape or a rectangular shape.

[0125] The second conducting member 62 is not limited to having the configuration described above, and may not include the fourth wiring portion 624. However, the second conducting member 62 is preferably provided with the fourth wiring portion 624 in order to reduce the inductance value due to the current flowing through the second conducting member 62.

[0126] The first conductive bonding member 71 is provided between the conductive substrate 2 and the supporting substrate 3 to electrically bond the conductive substrate 2 and the supporting substrate 3. The first conductive bonding member 71 includes a conductive bonding portion that electrically bonds the first conductive portion 2A to the first portion 32A, and a conductive bonding portion that electrically bonds the second conductive portion 2B to the second portion 32B. As shown in FIG. 15, the first conductive bonding member 71 includes a first base layer 711, a first layer 712, and a second layer 713 that are stacked on each other.

[0127] As shown in FIG. 15, it is most preferable that a side surface of the first conductive bonding member 71 and a side surface of the first metal layer 32, which is the top layer of the supporting substrate 3, be flush with each other. It is preferable that in plan view, the side surface of the first metal layer 32 is positioned slightly more inward than the side surface of the first conductive bonding member 71. That is, in plan view, bonding is performed such that the side surface of the first metal layer 32 does not extend outward from the side surface of the first conductive bonding member 71. If the side surface of the first metal layer 32 extends more outward than the side surface of the first conductive bonding member 71 in plan view, the creepage distance between the first metal layer 32 and the second metal layer 33 becomes undesirably small. In plan view, the side surface of the first metal layer 32 is positioned more outward than a side surface of the base member 21 in the conductive substrate 2.

[0128] The first base layer 711 is made of a metal, such as Al or an Al alloy. The first base layer 711 is made of a sheet material. The Young's modulus of aluminum (Al), which is the material of the first base layer 711, is 70.3 GPa.

[0129] The first layer 712 is formed on the upper surface of the first base layer 711. The first layer 712 is provided between the first base layer 711 and the conductive substrate 2 (each of the first conductive portion 2A and the second conductive portion 2B). The first layer 712 is a Ag plating layer, for example. The first layer 712 is bonded to the respective reverse-surface bonding layers 23 of the first conductive portion 2A and the second conductive portion 2B by the solid-phase diffusion of metal, for example. In other words, the first layer 712 and the reverse-surface bonding layers 23 of the first conductive portion 2A and the second conductive portion 2B are bonded by solid-phase diffusion. As a result, the first layer 712 and the reverse-surface bonding layers 23 are bonded in direct contact with each

other at the bonding interface. In the present disclosure, “A and B are bonded by solid-phase diffusion” means that as a result of solid-phase diffusion bonding, A and B are fixed to each other in direct contact at the bonding interface, where A and B constitute a solid-phase diffusion layer. When solid-phase diffusion bonding is performed under an ideal condition, the bonding interface may not exist clearly due to the diffusion of metal elements. On the other hand, when an inclusion such as an oxidation film is formed on the surface layers of A and B, or when there is a gap between A and B, the inclusion or the gap may exist at the bonding interface.

[0130] The second layer 713 is formed on the lower surface of the first base layer 711. The second layer 713 is provided between the first base layer 711 and the supporting substrate 3 (each of the first portion 32A and the second portion 32B). The second layer 713 is a Ag plating layer, for example. The second layer 713 is bonded to the first bonding layer 321 formed on each of the first portion 32A and the second portion 32B by solid-phase diffusion of metal. In other words, the second layer 713 and the first bonding layer 321 are bonded by solid-phase diffusion in direct contact with each other at the bonding interface. The Young's modulus of silver (Ag), which is the material of the first layer 712 and the second layer 713, is 82.7 GPa.

[0131] Since the first base layer 711, the first layer 712, and the second layer 713 in the first conductive bonding member 71 are made of the materials described above, the Young's modulus of the first base layer 711 is smaller than the Young's modulus of each of the first layer 712 and the second layer 713. The thickness (dimension in the z direction) of the first base layer 711 is greater than the thickness of each of the first layer 712 and the second layer 713.

[0132] In the first conductive bonding member 71, an end surface of the first base layer 711, which is made of A1 or an A1 alloy, is not plated with Ag, so that the end surface of the first base layer 711 is exposed. Note that the end surface of the first base layer 711 may be plated with Ag. In view of reducing the manufacturing cost of the first conductive bonding member 71, it is preferable to fabricate the first conductive bonding member 71 by forming Ag plating on both surfaces of a large sheet material and then cutting the Ag-plated sheet material. In this regard, it is preferable that the end surface of the first base layer 711 not be plated with Ag.

[0133] The second conductive bonding member 72 is provided between the conductive substrate 2 and the semiconductor elements 10 to electrically bond the conductive substrate 2 and the semiconductor elements 10. The second conductive bonding member 72 includes a conductive bonding portion that electrically bonds the first semiconductor elements 10A to the first conductive portion 2A, and a conductive bonding portion that electrically bonds the second semiconductor elements 10B to the second conductive portion 2B. As shown in FIG. 15, the second conductive bonding member 72 includes a second base layer 721, a third layer 722, and a fourth layer 723 that are stacked on each other.

[0134] The second base layer 721 is made of a metal, such as A1 or an A1 alloy. The second base layer 721 is made of a sheet material.

[0135] The third layer 722 is formed on the upper surface of the second base layer 721. The third layer 722 is provided between the second base layer 721 and the semiconductor elements 10. The third layer 722 is a Ag plating layer, for

example. The third layer 722 is bonded to the reverse-surface electrodes 15 of the semiconductor elements 10 by the solid-phase diffusion of metal, for example. In other words, the third layer 722 and the reverse-surface electrodes 15 are bonded by solid-phase diffusion in direct contact with each other at the bonding interface.

[0136] The fourth layer 723 is formed on the lower surface of the second base layer 721. The fourth layer 723 is provided between the second base layer 721 and the conductive substrate 2 (each of the first conductive portion 2A and the second conductive portion 2B). The fourth layer 723 is a Ag plating layer, for example. The fourth layer 723 is bonded to the respective obverse-surface bonding layers 22 of the first conductive portion 2A and the second conductive portion 2B by the solid-phase diffusion of metal, for example. In other words, the fourth layer 723 and the obverse-surface bonding layers 22 are bonded by solid-phase diffusion in direct contact with each other at the bonding interface.

[0137] Since the second base layer 721, the third layer 722, and the fourth layer 723 in the second conductive bonding member 72 are made of the materials described above, the Young's modulus of the second base layer 721 is smaller than the Young's modulus of each of the third layer 722 and the fourth layer 723. The thickness (dimension in the z direction) of the second base layer 721 is greater than the thickness of each of the third layer 722 and the fourth layer 723.

[0138] In the second conductive bonding member 72, an end surface of the second base layer 721, which is made of A1 or an A1 alloy, is not plated with Ag, so that the end surface of the second base layer 721 is exposed. Note that the end surface of the second base layer 721 may be plated with Ag. In view of reducing the manufacturing cost of the second conductive bonding member 72, it is preferable to fabricate the second conductive bonding member 72 by forming Ag plating on both surfaces of a large sheet material and then cutting the Ag-plated sheet material. In this regard, it is preferable that the end surface of the second base layer 721 not be plated with Ag.

[0139] Each of the wires 731 to 735 electrically connects two members that are separated from each other. The wires 731 to 735 are bonding wires, for example. The material of each of the wires 731 to 735 contains one of gold (Au), A1, or Cu, for example.

[0140] As shown in FIG. 8, each of the wires 731 is bonded to and electrically connects the first obverse-surface electrode 11 (gate electrode) of a semiconductor element 10 and a first portion 521 (first metal layer 52) of the control terminal support 5. As shown in FIG. 8, the plurality of wires 731 include a plurality of first wires 731a and a plurality of second wires 731b. Each of the first wires 731a is connected to the first obverse-surface electrode 11 (gate electrode) of one of the first semiconductor elements 10A and the first portion 521 (first metal layer 52) of the first supporting portion 5A. As a result, the first control terminal 46A is electrically connected to the first obverse-surface electrodes 11 (gate electrodes) of the first semiconductor elements 10A via the first wires 731a. Each of the second wires 731b is connected to the first obverse-surface electrode 11 (gate electrode) of one of the second semiconductor elements 10B and the first portion 521 (first metal layer 52) of the second supporting portion 5B. As a result, the second control terminal 47A is electrically connected to the first obverse-

surface electrodes **11** (gate electrodes) of the second semiconductor elements **10B** via the second wires **731b**.

[0141] As shown in FIG. 8, each of the wires **732** is bonded to and electrically connects the second obverse-surface electrode **12** (source electrode) of a semiconductor element **10** and a second portion **522** (first metal layer **52**) of the control terminal support **5**. As for each of the semiconductor elements **10** having the diode function units **D1**, the wire **732** is bonded to the fifth obverse-surface electrode **16** (source sense electrode) instead of the second obverse-surface electrode **12** (source electrode).

[0142] As shown in FIG. 8, each of the wires **733** is bonded to and electrically connects the third obverse-surface electrode **13** of one of the semiconductor elements **10** having the diode function units **D1** and a third portion **523** (first metal layer **52**) of the control terminal support **5**.

[0143] As shown in FIG. 8, each of the wires **734** is bonded to and electrically connects the fourth obverse-surface electrode **14** of one of the semiconductor elements **10** having the diode function units **D1** and a fourth portion **524** (first metal layer **52**) of the control terminal support **5**.

[0144] As shown in FIG. 8, the wire **735** is bonded to and electrically connects the obverse surface **201** of the first conductive portion **2A** (conductive substrate **2**) and the fifth portion **525** (first metal layer **52**) of the first supporting portion **5A** (control terminal support **5**).

[0145] The sealing resin **8** covers the semiconductor elements **10**, the conductive substrate **2**, the supporting substrate **3** (except the bottom surface **302**), parts of the input terminals **41** to **43**, parts of the output terminals **44**, parts of the control terminals **45**, the control terminal support **5**, the conducting member **6**, and the wires **731** to **735**. The sealing resin **8** is made of a black epoxy resin, for example. The sealing resin **8** may be formed by molding described below. The sealing resin **8** may have a dimension of about 35 mm to 60 mm in the x direction, a dimension of about 35 mm to 50 mm in the y direction, and a dimension of about 4 mm to 15 mm in the z direction. Each of these dimensions is the size of the largest portion along one of the directions. The sealing resin **8** has a resin obverse surface **81**, a resin reverse surface **82**, and a plurality of resin side surfaces **831** to **834**.

[0146] As shown in FIGS. 9, 11, and 12, for example, the resin obverse surface **81** and the resin reverse surface **82** are spaced apart from each other in the z direction. The resin obverse surface **81** faces in the z2 direction, and the resin reverse surface **82** faces in the z1 direction. The control terminals **45** (first control terminals **46A** to **46E** and the second control terminals **47A** to **47D**) protrude from the resin obverse surface **81**. As shown in FIG. 10, the resin reverse surface **82** has a frame shape surrounding the bottom surface **302** of the supporting substrate **3** (lower surface of the second metal layer **33**) in plan view. The bottom surface **302** of the supporting substrate **3** is exposed from the resin reverse surface **82**, and is flush with the resin reverse surface **82**, for example. The resin side surfaces **831** to **834** are joined to the resin obverse surface **81** and the resin reverse surface **82**, and are flanked by these surfaces in the z direction. As shown in FIG. 4, the resin side surface **831** and the resin side surface **832** are spaced apart from each other in the x direction. The resin side surface **831** faces in the x1 direction, and the resin side surface **832** faces in the x2 direction. The two output terminals **44** protrude from the resin side surface **831**, and the three input terminals **41** to **43** protrude from the resin side surface **832**. As shown in FIG.

4, for example, the resin side surface **833** and the resin side surface **834** are spaced apart from each other in the y direction. The resin side surface **833** faces in the y1 direction, and the resin side surface **834** faces in the y2 direction.

[0147] As shown in FIG. 4, the resin side surface **832** is formed with a plurality of recessed portions **832a**. The recessed portions **832a** are recessed in the x direction in plan view. The recessed portions **832a** include one formed between the input terminal **41** and the input terminal **42**, and one formed between the input terminal **41** and the input terminal **43** in plan view. The recessed portions **832a** are provided to increase the creepage distance between the input terminal **41** and the input terminal **42** along the resin side surface **832**, and to increase the creepage distance between the input terminal **41** and the input terminal **43** along the resin side surface **832**.

[0148] As shown in FIGS. 13 and 14, the sealing resin **8** has a plurality of first protrusions **851**, a plurality of second protrusions **852**, and resin voids **86**.

[0149] The first protrusions **851** protrude from the resin obverse surface **81** in the z direction. The first protrusions **851** are arranged near the four corners of the sealing resin **8** in plan view. The tip end (end in the z2 direction) of each of the first protrusions **851** is formed with a first protruding end surface **851a**. The first protruding end surfaces **851a** of the first protrusions **851** are substantially parallel to the resin obverse surface **81** and positioned on the same plane (x-y plane). Each of the first protrusions **851** has a bottomed hollow truncated cone shape, for example. The first protrusions **851** are used for an apparatus that uses a power supply generated by the semiconductor module **A1**, and function as spacers when the semiconductor module **A1** is mounted on, for example, a control circuit board of the apparatus. Each of the first protrusions **851** has a recessed portion **851b** and an inner wall surface **851c** formed in the recessed portion **851b**. It suffices for the first protrusions **851** to have a pillar shape, preferably a columnar shape. It is preferable that each of the recessed portions **851b** have a columnar shape, and each of the inner wall surfaces **851c** have a single perfect circular shape in plan view. Each of the first protrusions **851** is an example of a "protrusion", and each of the first protruding end surfaces **851a** is an example of a "protruding end surface".

[0150] The semiconductor module **A1** may be mechanically fixed to a control circuit board or the like by, for example, a screwing method. In this case, the threads of female screws may be formed in the inner wall surfaces **851c** of the recessed portions **851b** in the first protrusions **851**. It is also possible to embed an insert nut in the recessed portion **851b** of each of the first protrusions **851**.

[0151] As shown in FIG. 14, for example, the second protrusions **852** protrude from the resin obverse surface **81** in the z direction. The second protrusions **852** overlap with the control terminals **45** in plan view. The metal pins **452** of the control terminals **45** protrude from the second protrusions **852**. A part of each holder **451** (upper surface of each upper-end flange portion) is exposed from the upper end surface of each second protrusion **852**. Each of the second protrusions **852** has a truncated cone shape. The resin members **87** are provided on the second protrusions **852**.

[0152] As shown in FIG. 13, each of the resin voids **86** passes from the resin obverse surface **81** to the recessed portion **201a** formed in the obverse surface **201** of the conductive substrate **2** in the z direction. Each of the resin

voids **86** is formed to be tapered such that the cross-sectional area thereof decreases along the z direction from the resin obverse surface **81** to the recessed portion **201a**. A resin void edge **861** of each of the resin voids **86**, which is in contact with the obverse surface **201**, and a recess edge **201b** of each of the recessed portions **201a**, which is in contact with the obverse surface **201**, coincide with each other. The resin voids **86** are portions that are formed in a molding process described below, and in which the sealing resin **8** is not formed during the molding process.

[0153] The resin members **87** are provided on the second protrusions **852** of the sealing resin **8**. The resin members **87** cover parts of the control terminals **45**, i.e., parts (upper surfaces of the upper-end flange portions) of the holders **451** that are exposed from the sealing resin **8**, and parts of the metal pins **452**. For example, the resin members **87** are made of epoxy resin, as with the sealing resin **8**, but may be made of a material different from the material of the sealing resin **8**.

[0154] The resin-filling portions **88** are provided for the resin voids **86** to fill the resin voids **86**. For example, the resin-filling portions **88** are made of epoxy resin, as with the sealing resin **8**, but may be made of a material different from the material of the sealing resin **8**.

[0155] The following describes a method for manufacturing the semiconductor module **A1**, with reference to FIGS. **21** to **29**. FIG. **21** is a plan view illustrating a step of the method for manufacturing the semiconductor module **A1**. FIG. **22** is a schematic cross-sectional view illustrating a step of the method for manufacturing the semiconductor module **A1**. FIG. **23** is a plan view illustrating a step of the method for manufacturing the semiconductor module **A1**. FIG. **24** is a cut end view illustrating a step of the method for manufacturing the semiconductor module **A1**. FIG. **24** corresponds to the cross section shown in FIG. **13**. Each of FIGS. **25** and **28** is a partially enlarged cross-sectional view illustrating a step of the method for manufacturing the semiconductor module **A1**, and corresponds to an enlarged view of a part of the cross-section in FIG. **13**. Each of FIGS. **26**, **27**, and **29** is a partially enlarged cross-sectional view illustrating a step of the method for manufacturing the semiconductor module **A1**, and corresponds to an enlarged view of a part of the cross-section in FIG. **14**.

[0156] First, a plurality of semiconductor elements **10**, a conductive substrate **2**, a supporting substrate **3**, a plurality of input terminals **41** to **43**, and a plurality of output terminals **44** are prepared. The configurations of the semiconductor elements **10**, the conductive substrate **2**, and the supporting substrate **3** are as described above. At the stage of preparing them, the semiconductor elements **10**, the conductive substrate **2**, and the supporting substrate **3** are separately prepared and not bonded to each other. As shown in FIG. **21**, the conductive substrate **2**, the input terminals **41** to **43**, and the output terminals **44** are connected to each other, and may be made of the same lead frame. As shown in FIG. **21**, no recessed portion **201a** is formed in the obverse surface **201** of the conductive substrate **2**.

[0157] Next, as shown in FIG. **22**, the conductive substrate **2** is placed on the supporting substrate **3** via a first conductive bonding member **71**, and the semiconductor elements **10** are placed on the conductive substrate **2** via a second conductive bonding member **72**. Then, heat is applied while the lower surface of the supporting substrate **3** and the upper surfaces of the semiconductor elements **10** are held (see the

thick arrows in FIG. **22**). As a result, the semiconductor elements **10** and the conductive substrate **2** are bonded to each other by solid-phase diffusion, and the conductive substrate **2** and the supporting substrate **3** are bonded to each other by solid-phase diffusion. Specifically, the following elements are collectively bonded to each other by solid-phase diffusion: a first bonding layer **321** (supporting substrate **3**) on a first metal layer **32** and a second layer **713** (first conductive bonding member **71**); a first layer **712** (first conductive bonding member **71**) and a reverse-surface bonding layer **23** (conductive substrate **2**); a fourth layer **723** (second conductive bonding member **72**) and an obverse-surface bonding layer **22** (conductive substrate **2**); and a third layer **722** (second conductive bonding member **72**) and reverse-surface electrodes **15** of the semiconductor elements **10**. As for the conditions of the solid-phase diffusion, the heat temperature during bonding may be in the range of 200° C. to 350° C. inclusive, and the pressure applied (force for the holding) during the bonding may be in the range of 1 MPa to 100 MPa inclusive. The solid-phase diffusion bonding is assumed to be performed in the atmosphere, but it may be performed in vacuum instead. As a result, the conductive substrate **2** is bonded to the supporting substrate **3** via the first conductive bonding member **71**, and the semiconductor elements **10** are bonded to the conductive substrate **2** via the second conductive bonding member **72**. Note that the bonding between the conductive substrate **2** and the supporting substrate **3**, and the bonding between the conductive substrate **2** and the semiconductor elements **10** may be performed separately rather than collectively. However, it is more preferable to perform the bonding collectively in order to improve manufacturing efficiency.

[0158] In the case where the semiconductor elements **10** are placed on the conductive substrate **2** via the second conductive bonding member **72**, individual second conductive bonding members **72** corresponding to the respective semiconductor elements **10** may be provided as shown in FIGS. **16** and **17**. Alternatively, it is possible to provide a single second conductive bonding member **72** corresponding to the three semiconductor elements **10** shown in FIG. **16**.

[0159] Next, as shown in FIG. **23**, bonding of a control terminal support **5**, bonding of a plurality of holders **451** of a plurality of control terminals **45**, bonding of a plurality of wires **731** to **735**, bonding of a plurality of first conducting members **61**, and bonding of a second conducting member **62** are performed. The bonding of these elements may be performed in any suitable order.

[0160] Next, a sealing resin **8** is formed. The sealing resin **8** is formed by molding, for example. As shown in FIG. **24**, a mold **91** for a molding process is provided with pressing pins **911** as pressing members. The tip ends of the pressing pins **911** are in contact with the obverse surface **201** of the conductive substrate **2**. At this point, recessed portions **201a** are formed in the obverse surface **201** by the pressing force of the pressing pins **911** to the obverse surface **201**. The degree of recession (depth) of the recessed portions **201a** changes depending on the strength of the pressing force or the like. The pressing pins **911** in contact with the obverse surface **201** of a first conductive portion **2A** are inserted through openings **63** of the second conducting member **62**. Then, a flowable resin material is injected into a cavity space **919** of the mold **91** via a resin flow channel and a resin inlet (both not shown) in sequence. The injected flowable resin

material solidifies to form the sealing resin **8**. The sealing resin **8** thus formed has first protrusions **851**, second protrusions **852**, and resin voids **86**, which are all described above, as shown in FIGS. **25** and **26**. As shown in FIG. **25**, a resin void edge **861** of each of the resin voids **86**, which is in contact with the obverse surface **201**, and a recess edge **201b** of each of the recessed portions **201a**, which is in contact with the obverse surface **201**, coincide with each other. As shown in FIG. **26**, the upper surface of each of the holders **451** is exposed from a second protrusion **852** and flush with the upper surface of the second protrusion **852**. As is evident from FIGS. **24** and **25**, the resin voids **86** are formed by the pressing pins **911** as a result of the flowable resin material not being filled. Note that the pressing pins **911** may be movable pins. In this case, the pressing pins **911** are preferably provided in holes formed in the mold **91** and supported elastically. Each of the pressing members does not necessarily have a pin shape, and may have a block shape instead.

[0161] Next, the mold **91** is opened, and a molded body is taken out, where the molded body contains the lead frame including the conductive substrate **2**, and the sealing resin **8**. Then, the sealing resin **8** is separated from the resin that has solidified at the resin flow channel and the resin inlet. In this process, one or more resin separation marks are formed at either a first position or a second position on a resin side surface **831** of the sealing resin **8** in the  $x_1$  direction. Referring to FIG. **1**, the first position may correspond to at least one of two positions each close to a respective end of the resin side surface **831** in the  $y$  direction, or at least one of the edges of the respective ends. In the case where the separation mark is formed at one of the edges of the respective ends, it may be formed at a surface formed along the edge (C chamfered portion in plan view). Such an inclined surface may be a part of the resin side surface **831** of the sealing resin **8** in the  $x_1$  direction. The second position is located between the two output terminals **44** at the resin side surface **831** shown in FIG. **1**. The resin separation mark corresponds to the position of a resin inlet of the mold **91**, and is formed by separating the sealing resin **8** from the resin that has solidified at the resin inlet. In order to prevent unevenness of the resin flow, it is preferable that the resin be injected from the central position of the mold in the  $y$  direction. In this case, a resin separation mark is formed between the two output terminals **44**.

[0162] Next, as shown in FIG. **27**, metal pins **452** of the control terminals **45** are pressed into the respective holders **451**. Specifically, the metal pins **452**, each of which has a cross-sectional dimension slightly larger than the inner diameter of a tubular portion (see FIG. **26**) of each of the holders **451**, are inserted with pressure. As a result, the holders **451** and the metal pins **452** are mechanically fixed and electrically connected to each other. The holders **451** and the metal pins **452** may be electrically connected with solder, for example. Then, resin members **87** and resin-filling portions **88** are formed as shown in FIGS. **28** and **29**. The resin members **87** and the resin-filling portions **88** may be formed by potting.

[0163] Next, the lead frame is cut appropriately to separate the input terminals **41** to **43** and the output terminals **44**. For each of the input terminals **41** to **43** and the output terminals **44** shown in FIG. **21**, the area near the connecting portion (portion indicated by a dashed line in FIG. **21**) between the terminal and the outer frame portion of the lead frame may

be cut with a die or the like. At this point, the input terminals **41** to **43** are formed with tip surfaces **413**, **423**, and **433**, respectively, that have input-side machining marks. Each of the output terminals **44** is formed with a tip surface **443** that has an output-side machining mark. When the lead frame has tie bars that connect, in the  $y$  direction, terminals which are adjacent in the  $y$  direction, the tie bars may be cut with a die or the like. In this case, for each of the terminals, machining marks are formed on two side surfaces that face in the  $y$  direction. The semiconductor module **A1** shown in FIGS. **1** to **20** is manufactured through the steps described above.

[0164] The semiconductor module **A1** is mounted on a circuit board for control, for example. The metal pins **452** are inserted into pin holes of the circuit board on which the semiconductor module **A1** is mounted, and are connected to terminals near the pin holes. The input terminals **41**, **42**, and **43** have the input-side bonding surfaces **411**, **421**, and **431**, respectively, that face in one sense ( $z_2$  direction) of the  $z$  direction. Each of the output terminals **44** has an output-side bonding surface **441** facing in one sense ( $z_2$  direction) of the  $z$  direction. The input-side bonding surfaces **411**, **421**, **431**, and the output-side bonding surfaces **441** are connected with solder, for example, to the terminals of the circuit board on which the semiconductor module **A1** is mounted.

[0165] The following describes the current path from the input terminal **41** to the output terminals **44** in the semiconductor module **A1** in the present embodiment. The first main circuit current flows through a path that includes the input terminal **41**, the first conductive portion **2A**, the first semiconductor elements **10A**, the first conducting members **61**, the second conductive portion **2B**, and the output terminals **44**. The first main circuit current flows along the  $x$  direction between the second obverse-surface electrodes **12** of the first semiconductor elements **10A** and the second conductive portion **2B** via the first conducting members **61**. In the second conductive portion **2B**, the first main circuit current flows along the  $x$  direction and a direction slightly inclined from the  $x$  direction between the portions to which the first conducting members **61** are bonded and the output terminals **44**.

[0166] The path of a current from the output terminals **44** to the input terminal **42** and the input terminal **43** is described below. The second main circuit current flows through a path that includes the output terminals **44**, the second conductive portion **2B**, the second semiconductor elements **10B**, the second conducting member **62**, the input terminal **42**, and the input terminal **43**. The second conducting member **62**, forming the path of the second main circuit current, includes the third wiring portion **623** extending in the  $y$  direction and the first and second wiring portions **621**, **622** joined to the respective ends of the third wiring portion **623** so as to extend in the  $x_2$  direction. Thus, the second main circuit current flows through the third wiring portion **623** as well as the first wiring portion **621** and the second wiring portion **622**. Further, the path of the second main circuit current includes the two second band portions **626** disposed between the first wiring portion **621** and the second wiring portion **622** so as to extend in the  $x$  direction and also includes the first band portion **625** disposed between the first wiring portion **621** and the second wiring portion **622** so as to extend in the  $y$  direction. Thus, the second main circuit current flows through the first wiring portion **621** and the second wiring portion **622**.

[0167] The second main circuit current flows between the input terminals 42, 43, and the second obverse-surface electrodes 12 of the second semiconductor elements 10B via a path including the first wiring portion 621, the second wiring portion 622, the third wiring portion 623, the two second band portions 626, and the first band portion 625 in the second conducting member 62. In the first wiring portion 621, the second wiring portion 622, and the two second band portions 626, the second main circuit current flows along the x direction. The direction in which the first main circuit current flows is opposite from the direction in which the second main circuit current flows.

[0168] The direction in which the first main circuit current flows in the first conducting members 61 is the x direction, and the direction in which the second main circuit current flows in the first wiring portion 621, the second wiring portion 622, and the two second band portions 626 in the second conducting member 62 is also the x direction.

[0169] The following describes the operation and advantages of the semiconductor module A1.

[0170] The semiconductor module A1 includes the conductive substrate 2, the input terminals 41 to 43, the output terminals 44, and the conducting member 6. The conductive substrate 2 includes the first conductive portion 2A to which the first semiconductor elements 10A are bonded, and the second conductive portion 2B to which the second semiconductor elements 10B are bonded. The input terminal 41 is joined to the first conductive portion 2A, and is electrically connected to the first semiconductor elements 10A via the first conductive portion 2A. The input terminal 42 and the input terminal 43 are electrically connected to the second semiconductor elements 10B via the second conductive member 62 (conducting member 6). The output terminals 44 are joined to the second conductive portion 2B, and are electrically connected to the second semiconductor elements 10B via the second conductive portion 2B. The conducting member 6 includes the first conducting members 61 that electrically connect the first semiconductor elements 10A and the second conductive portion 2B, and the second conducting member 62 that electrically connects the second semiconductor elements 10B and the input terminals 42 and 43. The input terminals 41 to 43 are offset in the x2 direction relative to the conductive substrate 2, and the output terminals 44 are offset in the x1 direction relative to the conductive substrate 2. The two input terminals 42 and 43 are located opposite from each other with the input terminal 41 therebetween in the y direction. Suppose that a semiconductor module has a configuration different from the semiconductor module A1 in a manner such that no input terminal 43 is provided, and the input terminals 41 and 42 are arranged side by side in the y direction. In this case, variations may occur in the path of current flowing from the input terminal 41 to the output terminals 44 via the first semiconductor elements 10A, and in the path of current flowing from the output terminals 44 to the input terminal 42 via the second semiconductor elements 10B. In view of this, the semiconductor module A1 includes the two input terminals 42 and 43, and the two input terminals 42 and 43 flank the input terminal 41. This makes it possible to reduce variations in the path of a current flowing from the input terminal 41 to the output terminals 44 via the first semiconductor elements 10A, and to reduce variations in the path of a current flowing from the output terminals 44 to the input terminals 42 and 43 via the second semiconductor elements

10B. As a result, the parasitic inductance components of the semiconductor module A1 can be reduced. In other words, the semiconductor module A1 has a package configuration preferable for reducing parasitic inductance components.

[0171] In the semiconductor module A1, an upper arm current path and a lower arm current path overlap with each other in plan view. The upper arm current path is the path of a current flowing from the input terminal 41 to the output terminals 44 via the first conductive portion 2A, the first semiconductor elements 10A, the first conducting members 61, and the second conductive portion 2B. In the present embodiment, as seen from FIG. 5, the upper arm current path extends from the x2 direction side to the x1 direction side. The lower arm current path is the path of a current flowing from the output terminals 44 to the input terminal 42 via the second semiconductor elements 10B and the second conductive member 62. In the present embodiment, as seen from FIG. 5, the lower arm current path extends from the x1 direction side to the x2 direction side. With this configuration, the magnetic field generated by the current along the upper arm current path and the magnetic field generated by the current along the lower arm current path cancel each other out, thus enabling reduction of parasitic inductance components. In particular, the conducting member 6 (each of the first conducting members 61 and the second conducting member 62) in the semiconductor module A1 is made of a metal plate-like member, so that an area where the upper arm current path and the lower arm current path overlap with each other in plan view can be provided appropriately. In other words, the semiconductor module A1 has a package configuration preferable for reducing parasitic inductance components.

[0172] In the semiconductor module A1, the second conducting member 62 that forms the lower arm current path includes the first wiring portion 621, the second wiring portion 622, the third wiring portion 623, and the fourth wiring portion 624. The first wiring portion 621 and the second wiring portion 622 extend in the x direction, and are respectively connected to the input terminal 42 and the input terminal 43 that are arranged opposite from each other with the input terminal 41 therebetween in the y direction. The third wiring portion 623 is joined to the first wiring portion 621 and the second wiring portion 622, extends in the y direction, and is connected to the second semiconductor elements 10B. The fourth wiring portion 624 is joined to the first wiring portion 621 and the second wiring portion 622, and overlaps with the first semiconductor elements 10A in plan view. The second conductive member 62 including the first wiring portion 621, the second wiring portion 622, the third wiring portion 623, and the fourth wiring portion 624 is spaced apart from the obverse surface 201 (conductive substrate 2) in the z direction, and overlaps with a wide area of the obverse surface 201 in plan view. This configuration can appropriately reduce variations in the path of a current flowing from the output terminals 44 to the input terminals 42 and 43 via the second semiconductor elements 10B, and therefore is suitable in reducing parasitic inductance components.

[0173] The first semiconductor elements 10A and the second semiconductor elements 10B overlap with each other as viewed in the x direction. This configuration can suppress an increase in the dimension in the y direction of the conductive substrate 2 (first conductive portion 2A and the second conductive portion 2B) on which the first semicon-

ductor elements 10A and the second semiconductor elements 10B are arranged, and can therefore reduce the size of the semiconductor module A1.

[0174] The fourth wiring portion 624 of the second conductive member 62 has the first band portion 625 and the second band portions 626. The first band portion 625 is joined to the first wiring portion 621 and the second wiring portion 622, extends in the y direction, and overlaps with the first semiconductor elements 10A in plan view. Each of the second band portions 626 is connected to the first band portion 625 and the third wiring portion 623, and has a band shape extending in the x direction in plan view. The second band portions 626 are spaced apart from each other in the y direction and arranged substantially in parallel to each other. In plan view, one end of each band portion 626 is connected to a part of the first band portion 625, which is located between two first semiconductor elements 10A adjacent in the y direction, and the other end of each band portion 626 is connected to a part of the third wiring portion 623, which is located between two second semiconductor elements 10B adjacent in the y direction. This configuration can increase the size of the fourth wiring portion 624 (second conductive member 62) in plan view. This is more preferable for reducing parasitic inductance components.

[0175] The first band portion 625 has the protruding areas 625a protruding in the z2 direction relative to the other areas. The protruding areas 625a overlap with the first semiconductor elements 10A in plan view. According to the configuration in which the first band portion 625 has the protruding areas 625a, the first band portion 625 is prevented from making improper contact with the first conducting members 61 bonded to the first semiconductor elements 10A.

[0176] The third wiring portion 623 has the recessed areas 623a recessed in the z1 direction relative to the other areas. The recessed areas 623a are bonded to the respective second semiconductor elements 10B. This configuration can increase the size of the third wiring portion 623 (second conductive member 62) in plan view while electrically connecting the third wiring portion 623 (second conductive member 62) and the second semiconductor elements 10B in a suitable manner.

[0177] The semiconductor module A1 includes the conducting member 6 (first conducting members 61 and the second conducting member 62) having the configuration described above, and further includes the first control terminals 46A to 46E and the second control terminals 47A to 47D for controlling the first semiconductor elements 10A and the second semiconductor elements 10B. The first control terminals 46A to 46E and the second control terminals 47A to 47D are provided on the obverse surface 201 of the conductive substrate 2 and extend along the z direction. The semiconductor module A1 having this configuration can have a smaller size in plan view, and therefore is suitable for reducing the size in plan view while reducing parasitic inductance components.

[0178] The first control terminals 46A to 46E are supported by the first conductive portion 2A and offset in the x2 direction relative to the first semiconductor elements 10A. The second control terminals 47A to 47D are supported by the second conductive portion 2B and offset in the x1 direction relative to the second semiconductor elements 10B. The first control terminals 46A to 46E are arranged at intervals in the y direction, and the second control terminals

47A to 47D are also arranged at intervals in the y direction. As such, the first control terminals 46A to 46E and the second control terminals 47A to 47D are appropriately arranged in an area corresponding to the first semiconductor elements 10A that constitute the upper arm circuit, and in an area corresponding to the second semiconductor elements 10B that constitute the lower arm circuit, respectively. The semiconductor module A1 having this configuration is more preferable for downsizing while reducing parasitic inductance components.

[0179] Each of the first semiconductor elements 10A and the second semiconductor elements 10B has a first obverse-surface electrode 11 (gate electrode) facing in the z2 direction. The first control terminal 46A is connected to the first obverse-surface electrodes 11 (gate electrodes) of the first semiconductor elements 10A via the first wires 731a. The second control terminal 47A is connected to the first obverse-surface electrodes 11 (gate electrodes) of the second semiconductor elements 10B via the second wires 731b. This makes it possible to appropriately input, to the first obverse-surface electrodes 11, a drive signal for driving the first semiconductor elements 10A (second semiconductor elements 10B) that have a switching function, via the first control terminal 46A (second control terminal 47A) and the first wires 731a (second wires 731b).

[0180] When the semiconductor module A1 is mounted on a circuit board, the metal pins 452 are inserted into the pin holes of the circuit board on which the semiconductor module A1 is mounted, and are connected to terminals near the pin holes. The input terminals 41, 42, and 43 have the input-side bonding surfaces 411, 421, and 431, respectively, that face in one sense (z2 direction) of the z direction. The output terminals 44 have the output-side bonding surfaces 441 facing in one sense (z2 direction) of the z direction. The input-side bonding surfaces 411, 421, 431, and the output-side bonding surfaces 441 are connected with solder, for example, to the terminals of the circuit board on which the semiconductor module A1 is mounted. With this configuration, the power system circuit board to which the input terminals 41 to 43 and the output terminals 44 are connected and the control system circuit board to which the metal pins 452 are connected can be arranged in separation in the z direction. This achieves the following improvements. Firstly, an improvement is made in the degree of freedom regarding the arrangement of a signal terminal in the semiconductor module A1. Secondly, an improvement is made in the degree of freedom regarding the routing and length of a signal wire in the semiconductor module A1. Thirdly, an improvement is made in the degree of freedom regarding the arrangement of a circuit board by a user when the semiconductor module A1 is used.

[0181] In the semiconductor module A1, the control terminals 45 protrude from the resin obverse surface 81 and extend along the z direction. In a configuration different from that of the semiconductor module A1, the control terminals 45 may be arranged to extend along a plane (x-y plane) perpendicular to the z direction. This configuration has a limit to the size reduction in plan view. Accordingly, as in the semiconductor module A1, the control terminals 45 can be arranged to extend along the z direction, so that the size of the semiconductor module A1 can be reduced in plan view. In other words, the semiconductor module A1 has a package configuration preferable for the size reduction in plan view.

[0182] In the semiconductor module A1 of the present embodiment, the control terminal support 5 is provided between the control terminals 45 and the obverse surface 201 (conductive substrate 2). The control terminal support 5 has the insulating layer 51, and the control terminals 45 are supported by the conductive substrate 2 via the control terminal support 5. The configuration with the control terminal support 5 can support the control terminals 45 on the conductive substrate 2 appropriately while maintaining insulation from the conductive substrate 2.

[0183] The control terminal support 5 has a layout structure in which the insulating layer 51, the first metal layer 52, and the second metal layer 53 are stacked on each other. The control terminals 45 are bonded to the first metal layer 52, which is formed as the upper surface of the control terminal support 5, via the conductive bonding member 459. According to the configuration, the control terminals 45 can be electrically bonded to the control terminal support 5 (first metal layer 52) while utilizing an existing layout structure (e.g., DBC substrate) as the control terminal support 5.

[0184] Each of the semiconductor elements 10 has an element obverse surface 101 facing in the z2 direction, and an element reverse surface 102 facing in the z1 direction. A first obverse-surface electrode 11 (gate electrode) is provided on the element obverse surface 101. The first obverse-surface electrode 11 of each of the semiconductor elements 10 and the first metal layer 52 (first portion 521) are connected by a wire 731 that is electrically conductive. This makes it possible to input a drive signal for driving the semiconductor elements 10 having a switching function to the first obverse-surface electrodes 11 appropriately, via the control terminals 45, the first metal layer 52, and the wires 731.

[0185] Each of the control terminals 45 includes a holder 451 and a metal pin 452. The holder 451 is made of a conductive material, and includes a tubular portion. The metal pin 452 is a rod-like member extending in the z direction, and is pressed into the holder 451. A part (the upper surface of the upper-end flange portion) of the holder 451 is exposed from the sealing resin 8. According to this configuration, the sealing resin 8 is formed (by molding) such that the holder 451 is covered with the sealing resin 8 except a part (upper end surface) of the holder 451, and the upper end surface of the holder 451 is exposed from the sealing resin 8. This makes it possible to insert the metal pin 452 into the holder 451 after the sealing resin 8 is formed. Accordingly, with the configuration in which the control terminals 45 include the holders 451 and the metal pins 452, it is possible to avoid complexity of the mold 91 for a molding process. For this reason, this configuration is suitable for efficiently manufacturing the semiconductor module A1.

[0186] The semiconductor module A1 of the present embodiment includes the resin members 87 bonded to the sealing resin 8. The resin members 87 cover parts (upper surfaces of the upper-end flange portions) of the holders 451 that are exposed from the sealing resin 8, and parts of the metal pins 452. This configuration prevents foreign matter from entering the connecting portions between the holders 451 and the metal pins 452. The semiconductor module A1 having the above configuration is preferable in terms of durability and reliability.

[0187] The sealing resin 8 has the second protrusions 852 protruding from the resin obverse surface 81. The second

protrusions 852 surround the respective control terminals 45 in plan view. The metal pins 452 of the control terminals 45 protrude from the second protrusions 852. The resin members 87 are provided on the second protrusions 852. According to this configuration, the creepage distance between adjacent control terminals 45 along the resin obverse surface 81 can be increased. This is preferable for increasing the withstand voltage of the adjacent control terminals 45.

[0188] The conductive substrate 2 includes the first conductive portion 2A and the second conductive portion 2B that are spaced apart from each other in the x direction. The first conductive portion 2A is offset in the x2 direction relative to the second conductive portion 2B. The semiconductor elements 10 include the first semiconductor elements 10A bonded to the first conductive portion 2A, and the second semiconductor elements 10B bonded to the second conductive portion 2B. The control terminals 45 include the first control terminals 46A to 46E, and the second control terminals 47A to 47D. The first control terminals 46A to 46E are supported by the first conductive portion 2A, and arranged between the first semiconductor elements 10A and the input terminals 41, 42, etc., in the x direction. The second control terminals 47A to 47D are provided between the second semiconductor elements 10B and the output terminals 44 in the x direction. With this configuration, the control terminals 45 (the first control terminals 46A to 46E, and the second control terminals 47A to 47D) are appropriately arranged in an area corresponding to the first semiconductor elements 10A that constitute the upper arm circuit, and in an area corresponding to the second semiconductor elements 10B that constitute the lower arm circuit. The configuration is preferable for downsizing the semiconductor module A1.

[0189] The sealing resin 8 has the first protrusions 851 protruding from the resin obverse surface 81. The tip end of each of the first protrusions 851 is formed with a first protruding end surface 851a. The first protruding end surfaces 851a of the first protrusions 851 are substantially parallel to the resin obverse surface 81 and positioned on the same plane (x-y plane). With this configuration, it is possible, in an apparatus that uses a power supply generated by the semiconductor module A1, to provide a predetermined gap between the surface of a control circuit board on which the semiconductor module A1 is mounted and the resin obverse surface 81. In this way, even when various functional components are mounted on a surface of the control circuit board that faces the semiconductor module A1, the functional components do not make improper contact with the sealing resin 8.

[0190] The semiconductor module A1 includes the conductive substrate 2 to which the semiconductor elements 10 are bonded. With this configuration, the heat generated by energization of the semiconductor elements 10 is transferred from the semiconductor elements 10 to the conductive substrate 2 and diffused at the conductive substrate 2. As such, the semiconductor module A1 has a package configuration preferable for improving the heat dissipation property of the semiconductor elements 10.

[0191] In the semiconductor module A1, the conductive substrate 2 and the supporting substrate 3 are bonded to each other via the first conductive bonding member 71. The first conductive bonding member 71 includes the first layer 712 and the second layer 713. The first layer 712 is bonded to the conductive substrate 2 by the solid-phase diffusion of metal, and is in direct contact with the conductive substrate 2 at the

bonding interface. The second layer 713 is bonded to the supporting substrate 3 by the solid-phase diffusion of metal, and is in direct contact with the supporting substrate 3 at the bonding interface. This configuration can increase the bonding strength between the conductive substrate 2 and the supporting substrate 3 as compared to the case where the conductive substrate 2 and the supporting substrate 3 are bonded by a bonding material such as solder. Accordingly, the semiconductor module A1 has a package configuration preferable for suppressing the peeling between the conductive substrate 2 and the support substrate 3.

[0192] In the semiconductor module A1, the semiconductor elements 10 and the conductive substrate 2 are bonded to each other via the second conductive bonding member 72. The second conductive bonding member 72 includes the third layer 722 and the fourth layer 723. The third layer 722 is bonded to the semiconductor elements 10 (reverse surface electrodes 15) by the solid-phase diffusion of metal, and is in direct contact with the semiconductor elements 10 at the bonding interface. The fourth layer 723 is bonded to the conductive substrate 2 by the solid-phase diffusion of metal, and is in direct contact with the conductive substrate 2 at the bonding interface. This configuration can increase the bonding strength between the semiconductor elements 10 and the conductive substrate 2 as compared to the case where the semiconductor elements 10 and the conductive substrate 2 are bonded by a bonding material such as solder. Accordingly, the semiconductor module A1 has a package configuration preferable for suppressing the peeling between the semiconductor elements 10 and the conductive substrate 2.

[0193] In the semiconductor module A1 of the present embodiment, the Young's modulus of the first base layer 711 in the first conductive bonding member 71 is smaller than the Young's modulus of the material of each of the first layer 712 and the second layer 713. According to the configuration, when the first conductive bonding member 71 is bonded to the conductive substrate 2 and the supporting substrate 3 by solid-phase diffusion, the stress is alleviated by the relatively soft first base layer 711, and the bonding boundary portion is thereby smoothed. As a result, the first layer 712 and the conductive substrate 2, as well as the second layer 713 and the supporting substrate 3, are more firmly bonded by solid-phase diffusion.

[0194] In the present embodiment, the first base layer 711 is thicker than each of the first layer 712 and the second layer 713. Accordingly, when bonding by solid-phase diffusion is performed, the pressing force acting on the boundary portion between the first layer 712 and the conductive substrate 2 (reverse-surface bonding layer 23) and on the boundary portion between the second layer 713 and the supporting substrate 3 (first bonding layer 321) is made more uniform. As a result, the first layer 712 and the conductive substrate 2, as well as the second layer 713 and the supporting substrate 3, can be in a stronger conductive bonding state.

[0195] The material of each of the first layer 712 and the second layer 713 contains silver. With this composition, when bonding by solid-phase diffusion is performed with the first conductive bonding member 71, oxidation of the first layer 712 and the second layer 713 is suppressed, thus enabling excellent solid-phase diffusion bonding. The reverse-surface bonding layer 23 and the first bonding layer 321, which are bonded to the first layer 712 and the second layer 713 respectively, also contain silver, thus enabling better solid-phase diffusion bonding.

[0196] In the present embodiment, the Young's modulus of the second base layer 721 in the second conductive bonding member 72 is smaller than the Young's modulus of the material of each of the third layer 722 and the fourth layer 723. According to the configuration, when the second conductive bonding member 72 is bonded to the semiconductor elements 10 (reverse-surface electrodes 15) and the conductive substrate 2 by solid-phase diffusion, the stress is alleviated by the relatively soft second base layer 721, and the bonding boundary portion is thereby smoothed. As a result, the third layer 722 and the semiconductor elements 10 (reverse-surface electrodes 15), as well as the fourth layer 723 and the conductive substrate 2, are more firmly bonded by solid-phase diffusion.

[0197] In the present embodiment, the second base layer 721 is thicker than each of the third layer 722 and the fourth layer 723. Accordingly, when bonding by solid-phase diffusion is performed, the pressing force acting on the boundary portion between the third layer 722 and the semiconductor elements 10 (reverse-surface electrodes 15) and on the boundary portion between the fourth layer 723 and the conductive substrate 2 (obverse-surface bonding layers 22) is made more uniform. As a result, the third layer 722 and the semiconductor elements 10 (reverse-surface electrodes 15), as well as the fourth layer 723 and the conductive substrate 2, can be in a stronger conductive bonding state.

[0198] The material of each of the third layer 722 and the fourth layer 723 contains silver. With this material composition, when bonding by solid-phase diffusion is performed with the second conductive bonding member 72, oxidation of the third layer 722 and the fourth layer 723 is suppressed, thus enabling excellent solid-phase diffusion bonding. The reverse-surface electrodes 15 and the obverse-surface bonding layers 22, which are bonded to the third layer 722 and the fourth layer 723 respectively, contain silver, thus enabling better solid-phase diffusion bonding.

[0199] The first conductive bonding member 71 has a configuration where the first layer 712 and the second layer 713, which are Ag plating layers, are formed on the surfaces (both surfaces) of the first base layer 711, which is made of a sheet material containing A1. Similarly, the second conductive bonding member 72 has a configuration where the third layer 722 and the fourth layer 723, which are Ag plating layers, are formed on the surfaces (both surfaces) of the second base layer 721, which is made of a sheet material containing A1. With this configuration, the first conductive bonding member 71 and the second conductive bonding member 72 can be easily prepared.

[0200] In the semiconductor module A1, the second conducting member 62 is formed with the openings 63. The openings 63 overlap with the obverse surface 201 (conductive substrate 2) in plan view, and do not overlap with the semiconductor elements 10 in plan view. With this configuration, during a molding step (step for forming the sealing resin 8) in the process for manufacturing the semiconductor module A1, the pressing pins 911 of the mold 91 can be inserted into the openings 63. This allows the pressing pins 911 to press the conductive substrate 2 without interfering with the second conducting member 62, thus suppressing the warpage of the supporting substrate 3 to which the conductive substrate 2 is bonded. The warpage occurs, for example, such that the outer sides of the supporting substrate 3 in the y direction are positioned more upward than the center thereof in the y direction. If warpage occurs on the support-

ing substrate 3, the bonding strength between the conductive substrate 2 and the supporting substrate 3 may be lowered. Furthermore, during a molding process, a part of the sealing resin 8 may be formed on the bottom surface 302 due to resin leakage, causing a bonding failure of a heat dissipating member (e.g., heat sink) that can be bonded to the bottom surface 302. Accordingly, the semiconductor module A1 has a package configuration that is preferable for improving the bonding strength between the conductive substrate 2 and the supporting substrate 3 by suppressing the warpage of the supporting substrate 3, and that is also preferable for suppressing the leakage of the sealing resin 8 to an unintended location.

[0201] The conductive substrate 2 includes the first conductive portion 2A to which the first semiconductor elements 10A are bonded, and the second conductive portion 2B to which the second semiconductor elements 10B are bonded. The first conductive portion 2A and the second conductive portion 2B are spaced apart from each other in the x direction, and the first conductive portion 2A is offset in the x2 direction relative to the second conductive portion 2B. The second conducting member 62 is connected to the second semiconductor elements 10B and the input terminals 42 and 43, and the openings 63 in the second conducting member 62 overlap with the obverse surface 201 of the first conductive portion 2A in plan view. With this configuration, even when the second conducting member 62 is designed to have a large size in plan view, the pressing pins 911 of the mold 91 can press the conductive substrate 2 without interfering with the second conducting member 62 during the formation (during the molding process) of the sealing resin 8. Note that the parasitic resistance components of the second conducting member 62 (conductive member 6) that forms the path of the main circuit current can be suppressed by increasing the size of the second conducting member 62 in plan view.

[0202] The second conducting member 62 includes the first wiring portion 621, the second wiring portion 622, the third wiring portion 623, and the fourth wiring portion 624. The first wiring portion 621 and the second wiring portion 622 extend in the x direction, and are respectively connected to the input terminal 42 and the input terminal 43 that are arranged opposite from each other with the input terminal 41 therebetween in the y direction. The third wiring portion 623 is joined to the first wiring portion 621 and the second wiring portion 622, extends in the y direction, and is connected to the second semiconductor elements 10B. The openings 63 are formed in the areas of the first wiring portion 621 and the second wiring portion 622 that are offset in the x2 direction. As such, the openings 63 are provided near two corners of the conductive substrate 2 (first conductive portion 2A) at respective outer sides of the conductive substrate 2 in the y direction. Accordingly, the openings 63 are provided near two corners of the supporting substrate 3 supporting the conductive substrate 2 (first conductive portion 2A) at the respective outer sides of the supporting substrate 3 in the y direction. The configuration as described above allows the size of the second conducting member 62 to be relatively large in plan view and, during the formation of the sealing resin 8 (molding process), areas near the two corners of the conductive substrate 2 (first conductive portion 2A) at the respective outer sides of the conductive substrate 2 in the y direction can be pressed with the pressing pins 911 of the mold 91 which are inserted into the openings 63. As

described above, the warpage of the supporting substrate 3 to which the conductive substrate 2 is bonded occurs such that the outer sides of the supporting substrate 3 in the y direction are positioned more upward than the center thereof in the y direction. However, the configuration described above can effectively suppress the warpage of the supporting substrate 3 during the molding process.

[0203] In the present embodiment, the conducting member 6 (the first conducting members 61 and the second conducting member 62) is made of a metal plate-like member. This facilitates formation of the openings 63 in the second conducting member 62. Furthermore, the conducting member 6 (the first conducting members 61 and the second conducting member 62) made of a metal plate-like member can easily adapt to various shapes and sizes, and can increase the reliability of a bonding portion with another component by securing a sufficient bonding area with the other component.

[0204] Parts of the obverse surface 201 of the conductive substrate 2 (first conductive portion 2A) overlap with the openings 63 in plan view and are formed with the recessed portions 201a. The recessed portions 201a are marks left by the pressing pins 911 applying a pressing force to the obverse surface 201 during the molding process. In the present embodiment, it is possible to devise an arrangement of the second conducting member 62 and the openings 63 formed therein, so that during the molding process, appropriate parts of the conductive substrate 2 (first conductive portion 2A) can be pressed with the pressing pins 911 while avoiding interference with functional elements such as the semiconductor elements 10.

[0205] The sealing resin 8 is formed with the resin voids 86 passing from the resin obverse surface 81 to the recessed portions 201a. Each of the resin voids 86 is tapered such that the cross-sectional area thereof decreases from the resin obverse surface 81 to the recessed portion 201a. The resin voids 86 are formed during a molding process (when the sealing resin 8 is formed). After the molding, the surfaces of the recessed portions 201a in the obverse surface 201 of the conductive substrate 2 are exposed from the sealing resin 8. In the present embodiment, the resin-filling portions 88 are provided for the resin voids 86 to fill the resin voids 86. This configuration can prevent foreign matter (such as moisture) from entering the recessed portions 201a exposed from the sealing resin 8. The semiconductor module A1 having the above configuration is preferable in terms of durability and reliability.

[0206] In the present embodiment, the openings 63 in the second conducting member 62 (conducting member 6) are through-holes that penetrate through in the z direction. This configuration can prevent a deviation of the current path caused by forming the openings 63 in the second conducting member 62 (conducting member 6) that forms the path of a main circuit current.

[0207] The semiconductor module A1 includes the conducting member 6. The conducting member 6 forms the path of a main circuit current switched by the semiconductor elements 10. The conducting member 6 includes the first conducting members 61 connected to the first semiconductor elements 10A, and the second conducting member 62 connected to the second semiconductor elements 10B. The conducting member 6 (each of the first conducting members 61 and the second conducting member 62) is made of a metal plate-like member. The main circuit current described

above may have a relatively large value. In this case, it is preferable to suppress the parasitic resistance components in the conducting member 6 that forms the path of the main circuit current in order to reduce the power consumption of the semiconductor module A1. Accordingly, in the semiconductor module A1, the conducting member 6 is made of a metal plate-like member instead of a bonding wire as described above to suppress the parasitic resistance components of the conducting member 6. In other words, the semiconductor module A1 has a package configuration preferable for suppressing the parasitic resistance components.

[0208] In the semiconductor module A1, each of the first semiconductor elements 10A has a rectangular shape in plan view, and the four corners of each of the first semiconductor elements 10A in plan view do not overlap with the second conducting member 62. According to this configuration, during the manufacturing process of the semiconductor module A1, it is possible to conduct visual inspection before forming the sealing resin 8 so as to check whether the first semiconductor elements 10A are properly bonded. In other words, the semiconductor module A1 allows for visual inspection regarding the bonding state of the first semiconductor elements 10A during the manufacturing process (e.g., the stage shown in FIG. 23). This makes it possible to determine whether the first semiconductor elements 10A are properly bonded. For example, it is possible to measure respective distances to the four corners of each first semiconductor element 10A by a laser ranging method, and determine that the first semiconductor element 10A is properly bonded if the difference between the distances to the four corners is small. As described above, the semiconductor module A1 can conduct visual inspection during the manufacturing process, and therefore has package configuration preferable for improving reliability. During the visual inspection, it is sufficient if at least three of the four corners of each of the first semiconductor elements 10A are visible in plan view. For this reason, it is sufficient if three corners of each of the first semiconductor elements 10A do not overlap with the second conducting member 62. Similarly, as shown in FIG. 5, four corners of each of the second semiconductor elements 10B do not overlap with the second conducting member 62. Accordingly, during the manufacturing process of the semiconductor module A1, it is possible to conduct visual inspection before forming the sealing resin 8 so as to check whether the second semiconductor elements 10B are properly bonded. The visual inspection may be automatic visual inspection that uses image-capturing and image processing.

[0209] The second conducting member 62 includes the first wiring portion 621, the second wiring portion 622, the third wiring portion 623, and the fourth wiring portion 624. The first wiring portion 621 and the second wiring portion 622 extend in the x direction, and are respectively connected to the input terminal 42 and the input terminal 43 that are arranged opposite from each other with the input terminal 41 therebetween in the y direction. The third wiring portion 623 is joined to the first wiring portion 621 and the second wiring portion 622, extends in the y direction, and is connected to the second semiconductor elements 10B. The fourth wiring portion 624 is joined to the first wiring portion 621 and the second wiring portion 622. The fourth wiring portion 624 is offset in the x2 direction relative to the third wiring portion 623, and overlaps with the first semiconductor elements 10A

in plan view. The second conductive member 62 including the first wiring portion 621, the second wiring portion 622, the third wiring portion 623, and the fourth wiring portion 624 overlaps with a wide area of the obverse surface 201 in plan view, and has a relatively large size in plan view. Increasing the size of the second conducting member 62 in plan view is preferable in terms of suppressing the parasitic resistance components of the second conducting member 62 (conductive member 6) that forms the path of the main circuit current.

[0210] Each of the first semiconductor elements 10A has a first side 191, a second side 192, a third side 193, and a fourth side 194 in plan view. The first side 191 and the second side 192 extend in the y direction. The first side 191 is an edge located in the x2 direction in plan view, and the second side 192 is an edge located in the x1 direction in plan view. The third side 193 and the fourth side 194 extend in the x direction. The third side 193 is an edge located in the y2 direction in plan view, and the fourth side 194 is an edge located in the y1 direction in plan view. Since each of the first semiconductor elements 10A has a rectangular shape in plan view, the four corners formed by the first side 191, the second side 192, the third side 193, and the fourth side 194 are generally right-angled in plan view. The fourth wiring portion 624 (the first band portion 625) of the second conducting member 62 has a first edge 627 and a second edge 628. The first edge 627 is an edge of the fourth wiring portion 624 located in the x2 direction, and is offset in the x1 direction relative to the first side 191 in plan view. The first edge 627 extends at least from the third side 193 to the fourth side 194 in the y direction. As such, two corners 171 and 172 of each first semiconductor element 10A in the x2 direction do not overlap with the second conducting member 62 in plan view. The second edge 628 is an edge of the fourth wiring portion 624 (first band portion 625) located in the x1 direction, and is offset in the x2 direction relative to the second side 192 in plan view. The second edge 628 extends at least from the third side 193 to the fourth side 194 in the y direction. As such, two corners 173 and 174 of each first semiconductor element 10A in the x1 direction do not overlap with the second conducting member 62 in plan view. With this configuration, the four corners of each of the first semiconductor elements 10A in plan view do not overlap with the second conducting member 62 while the size of the second conducting member 62 in plan view is increased by providing the fourth wiring portion 624 with areas that overlap with the first semiconductor elements 10A in plan view. This makes it possible to effectively suppress the parasitic resistance components of the second conducting member 62 (conducting member 6), and to conduct visual inspection to check the bonding state of the first semiconductor elements 10A during the manufacturing process of the semiconductor module A1.

[0211] The fourth wiring portion 624 (first band portion 625) has the protruding areas 625a protruding in the z2 direction relative to the other areas. The protruding areas 625a overlap with the first semiconductor elements 10A in plan view. According to the configuration in which the fourth wiring portion 624 has the protruding areas 625a, the fourth wiring portion 624 is prevented from making improper contact with the first conducting members 61 bonded to the first semiconductor elements 10A.

[0212] The third wiring portion 623 has the recessed areas 623a recessed in the z1 direction relative to the other areas.

The recessed areas **623a** are bonded to the respective second semiconductor elements **10B**. This configuration can increase the size of the third wiring portion **623** (second conductive member **62**) in plan view while electrically connecting the third wiring portion **623** (second conductive member **62**) and the second semiconductor elements **10B** in a suitable manner.

[0213] The first semiconductor elements **10A** and the second semiconductor elements **10B** overlap with each other as viewed in the x direction. This configuration can suppress an increase in the dimension in the y direction of the conductive substrate **2** (first conductive portion **2A** and the second conductive portion **2B**) on which the first semiconductor elements **10A** and the second semiconductor elements **10B** are arranged, and can therefore reduce the size of the semiconductor module **A1**.

[0214] The semiconductor module **A1** includes the conductive substrate **2**, the two input terminals **41** and **42** (or the two input terminals **41** and **43**), the output terminals **44**, and the conducting member **6**. The conductive substrate **2** includes the first conductive portion **2A** and the second conductive portion **2B** aligned in the x direction in plan view. The first semiconductor elements **10A** are electrically bonded to the first conductive portion **2A**. The second semiconductor elements **10B** are electrically bonded to the second conductive portion **2B**. The first semiconductor elements **10A** and the second semiconductor elements **10B** are arranged at intervals in the y direction. The two input terminals **41** and **42** (or the two input terminals **41** and **43**) are offset in the x2 direction relative to the first conductive portion **2A**. The input terminal **41** is a positive electrode, and is connected to the first conductive portion **2A**. The input terminal **42** (or the input terminal **43**) is a negative electrode. The output terminals **44** are offset in the x1 direction relative to the second conductive portion **2B**. The conducting member **6** includes the first conducting members **61** connected to the first semiconductor elements **10A** and the second conductive portion **2B**, and the second conducting member **62** connected to the second semiconductor elements **10B** and the input terminal **42** (or the input terminal **43**). According to this configuration, the path of the main circuit current switched by the semiconductor elements **10** (the first semiconductor elements **10A** and the second semiconductor elements **10B**) is formed along the x direction in plan view, and the axis of symmetry (see an auxiliary line **L1** in FIG. 5) in the planar structure of the semiconductor module **A1** extends along the y direction in plan view. In other words, the axis of symmetry and the path of the main circuit current are perpendicular to each other. This reduces the difference in the current path to the first semiconductor elements **10A** and the second semiconductor elements **10B** regarding the main circuit current inputted from the two input terminals **41** and **42** (or the two input terminals **41** and **43**) and outputted from the output terminals **44**. Accordingly, it is possible to suppress variations in parasitic inductance components and variations in current in the semiconductor module **A1**. Accordingly, the semiconductor module **A1** has a package configuration preferable for equalizing the parasitic inductance components in the path of the main circuit current and for equalizing the amount of current to the semiconductor elements **10**.

[0215] The first semiconductor elements **10A** and the second semiconductor elements **10B** are spaced apart in the x direction. The first semiconductor elements **10A** and the

second semiconductor elements **10B** are aligned along the y direction. Accordingly, the direction in which the semiconductor elements **10** are aligned is perpendicular to the direction in which the first main circuit current or the second main circuit current flows. In this way, when a plurality of switching elements are connected in parallel for use as in the present embodiment, the difference in the length of the path of the first main circuit current between the three first semiconductor elements **10A** can be reduced. This makes it possible to suppress the parasitic resistance components in the conducting member **6** that forms the path of the main circuit current.

[0216] The area in which the first main circuit current flows and the area in which the second main circuit current flows overlap with each other in plan view. In other words, the second conducting member **62**, which connects the output terminals **44** to the input terminals **42** and **43** that are negative electrode terminals to let the second main circuit current flow, is arranged above the area (the first conductive portion **2A**, the first conducting members **61**, and the second conductive portion **2B**) in which the first main circuit current flows. The direction in which the first main circuit current flows is opposite from the direction in which the second main circuit current flows. With the arrangement described above, the magnetic field generated by the first main circuit current and the magnetic field generated by the second main circuit current cancel each other out, thus enabling reduction of inductance.

[0217] The semiconductor module **A1** of the present embodiment includes the two input terminals **42** and **43**. The input terminals **42** and **43** are negative electrodes and flank the input terminal **41** in the y direction. The two input terminals **42** and **43** are connected to the second conducting member **62**. This configuration can further reduce variations in the path of a current flowing from the output terminals **44** to the input terminals **42** and **43** via the second semiconductor elements **10B** and the second conducting member **62**.

[0218] In the semiconductor module **A1**, the second conducting member **62** includes the first wiring portion **621**, the second wiring portion **622**, the third wiring portion **623**, and the fourth wiring portion **624**. The first wiring portion **621** and the second wiring portion **622** extend in the x direction, and are respectively connected to the input terminal **42** and the input terminal **43** that are arranged opposite from each other with the input terminal **41** therebetween in the y direction. The third wiring portion **623** is joined to the first wiring portion **621** and the second wiring portion **622**, extends in the y direction, and is connected to the second semiconductor elements **10B**. The fourth wiring portion **624** is offset in the x2 direction relative to the third wiring portion **623**, and is joined to the first wiring portion **621**, the second wiring portion **622**, and the third wiring portion **623**. The second conductive member **62** including the first wiring portion **621**, the second wiring portion **622**, the third wiring portion **623**, and the fourth wiring portion **624** overlaps with a wide area of the obverse surface **201** in plan view, and has a relatively large size in plan view. This configuration can appropriately reduce variations in the path of a current flowing from the output terminals **44** to the input terminals **42** and **43** via the second semiconductor elements **10B** and the second conducting member **62**. Accordingly, the semiconductor module **A1** of the present embodiment is more preferable for equalizing the parasitic inductance components in the path (second conducting member **62**) of the

main circuit current and for equalizing the amount of current to the semiconductor elements 10B.

[0219] The fourth wiring portion 624 is joined to the first wiring portion 621 and the second wiring portion 622, and overlaps with the first semiconductor elements 10A in plan view. The fourth wiring portion 624 (first band portion 625) has the protruding areas 625a protruding in the z direction relative to the other areas. The protruding areas 625a overlap with the first semiconductor elements 10A in plan view. This configuration can increase the size of the fourth wiring portion 624 (second conductive member 62) in plan view, and can prevent the fourth wiring portion 624 from making improper contact with the first conducting members 61 bonded to the first semiconductor elements 10A.

[0220] The first semiconductor elements 10A and the second semiconductor elements 10B overlap with each other as viewed in the x direction. This configuration can suppress an increase in the dimension in the y direction of the conductive substrate 2 (first conductive portion 2A and the second conductive portion 2B) on which the first semiconductor elements 10A and the second semiconductor elements 10B are arranged, and can therefore reduce the size of the semiconductor module A1.

[0221] FIGS. 30 to 32 illustrate a semiconductor module according to a second embodiment. A semiconductor module A2 of the present embodiment is different from the semiconductor module A1 of the first embodiment in the configuration of the sealing resin 8.

[0222] In the present embodiment, the sealing resin 8 does not include the second protrusions 852. As shown in FIG. 32, the resin obverse surface 81 of the sealing resin 8 is flush with the upper surface of the upper-end flange portion of each of the holders 451. As such, a part (the upper surface of the upper-end flange portion) of each of the holders 451 is exposed from the sealing resin 8. A resin member 87 is provided on the upper surface of the upper-end flange portion of each of the holders 451 and on an area of the resin obverse surface 81 surrounding the upper surface of the upper-end flange portion of the holder 451. The resin members 87 cover parts of the control terminals 45, i.e., parts (upper surfaces of the upper-end flange portions) of the holders 451 that are exposed from the sealing resin 8, and parts of the metal pins 452.

[0223] The semiconductor module A2 of the present embodiment has the same advantages as the semiconductor module A1 of the first embodiment.

[0224] FIGS. 33 to 35 illustrate a semiconductor module according to a third embodiment. A semiconductor module A3 of the present embodiment is different from the semiconductor module A2 of the second embodiment in the configurations of the resin members 87.

[0225] In the present embodiment, the sealing resin 8 does not include the second protrusions 852, and the resin obverse surface 81 of the sealing resin 8 is flush with the upper surface of the upper-end flange portion of each holder 451, as shown in FIG. 35. As a result, a part (the upper surface of the upper-end flange portion) of each holder 451 is exposed from the sealing resin 8, as in the case of the semiconductor module A2 shown in FIG. 32. On the other hand, in the present embodiment, a resin member 87 is provided on the upper surfaces of the upper-end flange portions of the holders 451 in the second control terminals 47A to 47D, and on the areas of the resin obverse surface 81 connected thereto. Also, another resin member 87 is pro-

vided on the upper surfaces of the upper-end flange portions of the holders 451 in the first control terminals 46A to 46E, and on the areas of the resin obverse surface 81 connected thereto. In the semiconductor module A2 (see FIG. 32), the plurality of resin members 87 are provided in correspondence with the holders 451 of the control terminals 45. In the present embodiment, however, a single resin member 87 is provided in correspondence with the first control terminals 46A to 46E, and another single resin member 87 is provided in correspondence with the second control terminals 47A to 47D. At the first control terminals 46A to 46E, the single resin member 87 covers parts (the upper surfaces of the upper-end flange portions) of the holders 451, which are exposed from the sealing resin 8, and also covers parts of the metal pins 452. At the second control terminals 47A to 47D, the other single resin member 87 covers parts (the upper surfaces of the upper-end flange portions) of the holders 451, which are exposed from the sealing resin 8, and also covers parts of the metal pins 452.

[0226] The semiconductor module A3 of the present embodiment has the same advantages as the semiconductor module A1 of the first embodiment.

[0227] FIGS. 36 and 37 show a semiconductor module according to a fourth embodiment. A semiconductor module A4 of the present embodiment is different from the semiconductor module A1 of the first embodiment in the configuration of the metal pin 452 of each of the control terminals 45.

[0228] In the present embodiment, the metal pin 452 of each of the control terminals 45 (the first control terminals 46A to 46E and the second control terminals 47A to 47D) has a cushion member 452a. The cushion member 452a absorbs a shock caused by vibrations and is exposed from the sealing resin 8. In the example shown in FIGS. 36 and 37, the cushion member 452a is provided at a position of the metal pin 452, which is near the resin member 87 in a lengthwise direction of the metal pin 452, and is configured as a member bent in a substantially U shape in a plane including the z direction.

[0229] The semiconductor module A4 of the present embodiment also has the same advantages as the semiconductor module A1 of the first embodiment. In the semiconductor module A4, each of the metal pins 452 (each of the control terminals 45) has a cushion member 452a. With this configuration, even if the semiconductor module A4 is provided for an electronic device (e.g., car device) that may generate relatively large vibrations, the cushion members 452a absorb the shock caused by the vibrations to thereby prevent the damage of the metal pins 452 (control terminals 45). Note that each of the cushion members 452a is not limited to having the specific configuration illustrated in the figure. Instead, each of the cushion members 452a may be an L-shaped bent member provided at the middle part of a metal pin 452.

[0230] FIGS. 38 to 40 show a semiconductor module according to a fifth embodiment. A semiconductor module A5 of the present embodiment is different from the semiconductor module A1 of the first embodiment in the configuration of the second conducting member 62.

[0231] The present embodiment is different from the first embodiment in the area occupied by the fourth wiring portion 624 of the second conducting member 62. Specifically, the dimension of the first band portion 625 in the x direction is larger than that of the semiconductor module A1.

As shown in FIGS. 39 and 40, the second edge 628 of the first band portion 625 is offset in the x1 direction as compared to the second edge 628 in the semiconductor module A1. As shown in FIG. 40, the second edge 628 is offset in the x1 direction relative to the second sides 192 of the first semiconductor elements 10A in plan view. As such, two corners of each first semiconductor element 10A in the x1 direction overlap with the second conducting member 62 (first band portion 625) in plan view.

[0232] The semiconductor module A5 of the present embodiment has the same advantages as the semiconductor module A1 of the first embodiment. Furthermore, in the semiconductor module A5, the first band portion 625 (second conducting member 62) of the fourth wiring portion 624 can have a larger size in plan view. This is more preferable for reducing parasitic inductance components.

[0233] FIGS. 41 and 42 illustrate a semiconductor module according to a sixth embodiment. A semiconductor module A6 of the present embodiment is different from the semiconductor module A1 of the first embodiment mainly in the configuration of the second conducting member 62.

[0234] Unlike the first embodiment, the second conducting member 62 of the semiconductor module A6 does not have any openings 63. The mold 91 used to form the sealing resin 8 (by molding) in the manufacturing of the semiconductor module A6 is not provided with the pressing pins 911. Accordingly, as shown in FIG. 42, the sealing resin 8 is not formed with the resin voids 86, and the obverse surface 201 of the conductive substrate 2 (the first conductive portion 2A and the second conductive portion 2B) is not formed with the recessed portions 201a. Since the sealing resin 8 is not formed with the resin voids 86, the semiconductor module A6 of the present embodiment does not have any resin-filling portions 88 which are used to fill the resin voids 86 in the first embodiment.

[0235] The semiconductor module A6 of the present embodiment has the same advantages as the semiconductor module A1 of the first embodiment.

[0236] The semiconductor module according to the present disclosure is not limited to the above embodiments. Various design changes can be made to the specific configurations of the elements of the semiconductor module in the present disclosure.

[0237] The present disclosure includes the configurations defined in the following clauses.

[0238] Clause 1.

[0239] A semiconductor module comprising:

[0240] a conductive substrate having an obverse surface facing in one sense of a thickness direction, and a reverse surface facing away from the obverse surface in the thickness direction;

[0241] at least one semiconductor element electrically bonded to the obverse surface and having a switching function;

[0242] at least one control terminal for controlling the at least one semiconductor element; and

[0243] a sealing resin having a resin obverse surface facing the same side as the obverse surface, and a resin reverse surface facing an opposite side from the resin obverse surface, the sealing resin covering the conductive substrate, the at least one semiconductor element, and a part of the at least one control terminal,

[0244] wherein the control terminal protrudes from the resin obverse surface, and extends along the thickness direction.

[0245] Clause 2.

[0246] The semiconductor module according to clause 1, [0247] wherein the sealing resin has a resin side surface that is connected to the resin obverse surface and the resin reverse surface, and that is flanked by the resin obverse surface and the resin reverse surface in the thickness direction,

[0248] the semiconductor module is provided with at least one power supply terminal protruding from the resin side surface, electrically connected to the semiconductor element, and handling power supply voltage, and

[0249] the power supply terminal has a bonding surface facing in the one sense of the thickness direction.

[0250] Clause 3.

[0251] The semiconductor module according to clause 2, wherein the at least one power supply terminal includes a first power supply terminal that receives a first power supply voltage and a second power supply terminal that outputs a second power supply voltage.

[0252] Clause 4.

[0253] The semiconductor module according to any of clauses 1 to 3, further comprising a control terminal support that is provided between the obverse surface and the control terminal, and that has an insulating layer.

[0254] Clause 5.

[0255] The semiconductor module according to clause 4, wherein the control terminal support has the insulating layer, a first metal layer stacked on a surface of the insulating layer in one sense of the thickness direction, and a second metal layer stacked on another surface of the insulating layer in another sense of the thickness direction and bonded to the conductive substrate to face the obverse surface.

[0256] Clause 6.

[0257] The semiconductor module according to clause 5, wherein the control terminal is bonded to the first metal layer via a conductive bonding member.

[0258] Clause 7.

[0259] The semiconductor module according to clause 6, further comprising a conductive wire,

[0260] wherein the semiconductor element has an element obverse surface facing the same side as the obverse surface, an element reverse surface facing an opposite side from the element obverse surface, and a gate electrode on the element obverse surface, and

[0261] the conductive wire is connected to the gate electrode and the first metal layer.

[0262] Clause 8.

[0263] The semiconductor module according to clause 6 or 7, wherein the control terminal includes a conductive tubular holder that is bonded to the first metal layer, and a metal pin pressed into the holder and extending in the thickness direction.

[0264] Clause 9.

[0265] The semiconductor module according to clause 8, wherein a part of the holder is exposed from the sealing resin in the one sense of the thickness direction.

[0266] Clause 10.

[0267] The semiconductor module according to clause 9, further comprising a resin member bonded to the sealing resin,

[0268] wherein the resin member covers a part of the holder that is exposed from the sealing resin, and a part of the metal pin.

[0269] Clause 11.

[0270] The semiconductor module according to clause 3, wherein the conductive substrate includes a first conductive portion and a second conductive portion that are spaced apart from each other in a first direction perpendicular to the thickness direction, such that the first conductive portion is offset in one sense of the first direction and the second conductive portion is offset in another sense of the first direction,

[0271] the at least one first power supply terminal includes a first input terminal that is offset in the one sense of the first direction relative to a first semiconductor element and connected to the first conductive portion, and a second input terminal that is offset in the one sense of the first direction relative to the first semiconductor element and connected to a second semiconductor element,

[0272] the second power supply terminal is an output terminal that is offset in the other sense of the first direction relative to the second semiconductor element and connected to the second conductive portion,

[0273] the at least one control terminal includes a first control terminal for controlling the first semiconductor element and a second control terminal for controlling the second semiconductor element,

[0274] the first control terminal is supported by the first conductive portion and provided between the first semiconductor element and each of the first input terminal and the second input terminal in the first direction, and

[0275] the second control terminal is supported by the second conductive portion and provided between the second semiconductor element and the output terminal in the first direction.

[0276] Clause 12.

[0277] The semiconductor module according to clause 11, further comprising:

[0278] a plurality of the first semiconductor elements arranged at intervals in a second direction perpendicular to the thickness direction and the first direction;

[0279] a plurality of the first control terminals arranged at intervals in the second direction;

[0280] a plurality of the second semiconductor elements arranged at intervals in the second direction; and

[0281] a plurality of the second control terminals arranged at intervals in the second direction.

[0282] Clause 13.

[0283] The semiconductor module according to any of clauses 1 to 12,

[0284] wherein the sealing resin has a plurality of protrusions, each of which protrudes from the resin obverse surface and has a protruding end surface formed at a tip end thereof, and

[0285] the protruding end surfaces of the plurality of protrusions are parallel to the resin obverse surface and on the same plane as the resin obverse surface.

[0286] Clause 14.

[0287] The semiconductor module according to any of clauses 1 to 13, wherein the at least one control terminal has a cushion member for absorbing a shock caused by vibrations.

[0288] Clause 15.

[0289] The semiconductor module according to clause 14, wherein the cushion member is exposed from the sealing resin.

[0290] Clause 16.

[0291] A semiconductor module comprising:

[0292] a conductive substrate having an obverse surface facing in one sense of a thickness direction, and a reverse surface facing away from the obverse surface in the thickness direction;

[0293] a semiconductor element electrically bonded to the obverse surface and having a switching function;

[0294] a control terminal for controlling the at least one semiconductor element; and

[0295] a sealing resin having a resin obverse surface facing the same side as the obverse surface, and a resin reverse surface facing an opposite side from the resin obverse surface, the sealing resin covering the conductive substrate, the at least one semiconductor element, and a part of the at least one control terminal,

[0296] wherein the control terminal protrudes from the resin obverse surface, and extends along the thickness direction.

[0297] Clause 17.

[0298] The semiconductor module according to clause 16, further comprising a control terminal support that is provided between the obverse surface and the control terminal, and that has an insulating layer.

[0299] Clause 18.

[0300] The semiconductor module according to clause 17, wherein the control terminal support has the insulating layer, a first metal layer stacked on a surface of the insulating layer in one sense of the thickness direction, and a second metal layer stacked on another surface of the insulating layer in another sense the thickness direction and bonded to the conductive substrate to face the obverse surface.

[0301] Clause 19.

[0302] The semiconductor module according to clause 18, wherein the control terminal is bonded to the first metal layer via a conductive bonding member.

[0303] Clause 20.

[0304] The semiconductor module according to clause 19,

[0305] wherein the semiconductor element has an element obverse surface facing the same side as the obverse surface, an element reverse surface facing an opposite side from the element obverse surface, and a gate electrode on the element obverse surface, and

[0306] the gate electrode and the first metal layer are connected to a conductive wire.

[0307] Clause 21.

[0308] The semiconductor module according to clause 19 or 20, wherein the control terminal includes a conductive tubular holder that is bonded to the first metal layer, and a metal pin pressed into the holder and extending in the thickness direction.

[0309] Clause 22.

[0310] The semiconductor module according to clause 21, wherein a part of the holder is exposed from the sealing resin in the one sense of the thickness direction.

[0311] Clause 23.

[0312] The semiconductor module according to clause 22, further comprising

[0313] a resin member bonded to the sealing resin,

[0314] wherein the resin member covers a part of the holder that is exposed from the sealing resin, and a part of the metal pin.

[0315] Clause 24.

[0316] The semiconductor module according to any of clauses 16 to 23,

[0317] wherein the conductive substrate includes a first conductive portion and a second conductive portion that are spaced apart from each other as viewed in the thickness direction, the first conductive portion being offset in one sense of a first direction that is perpendicular to the thickness direction, the second conductive portion being offset in another sense of the first direction, and

[0318] the at least one semiconductor element includes a first semiconductor element electrically bonded to the first conductive portion, and a second semiconductor element electrically bonded to the second conductive portion,

[0319] the semiconductor module further comprising:

[0320] a first input terminal that is offset in the one sense of the first direction relative to the first semiconductor element and connected to the first conductive portion;

[0321] a second input terminal that is offset in the one sense of the first direction relative to the first semiconductor element and connected to the second semiconductor element; and

[0322] an output terminal that is offset in the other sense of the first direction relative to the second semiconductor element and connected to the second conductive portion,

[0323] wherein the at least one control terminal includes a first control terminal for controlling the first semiconductor element and a second control terminal for controlling the second semiconductor element,

[0324] the first control terminal is supported by the first conductive portion and provided between the first semiconductor element and each of the first input terminal and the second input terminal in the first direction, and

[0325] the second control terminal is supported by the second conductive portion and provided between the second semiconductor element and the output terminal in the first direction.

[0326] Clause 25.

[0327] The semiconductor module according to clause 24, further comprising:

[0328] a plurality of the first semiconductor elements arranged at intervals in a second direction perpendicular to the thickness direction and the first direction;

[0329] a plurality of the first control terminals arranged at intervals in the second direction;

[0330] a plurality of the second semiconductor elements arranged at intervals in the second direction; and

[0331] a plurality of the second control terminals arranged at intervals in the second direction.

[0332] Clause 26.

[0333] The semiconductor module according to any of clauses 16 to 25,

[0334] wherein the sealing resin has a plurality of protrusions, each of which protrudes from the resin obverse surface and has a protruding end surface formed at a tip end thereof, and

[0335] the protruding end surfaces of the plurality of protrusions are parallel to the resin obverse surface and on the same plane as the resin obverse surface.

[0336] Clause 27.

[0337] The semiconductor module according to any of clauses 16 to 26, wherein the at least one control terminal has a cushion member for absorbing a shock caused by vibrations.

[0338] Clause 28.

[0339] The semiconductor module according to clause 27, wherein the cushion member is exposed from the sealing resin.

#### REFERENCE NUMERALS

[0340] A1, A2, A3, A4, A5, A6: Semiconductor Module

[0341] 10: At least one semiconductor element

[0342] 10A: First semiconductor element

[0343] 10B: Second semiconductor element

[0344] 101: Element Obverse Surface

[0345] 102: Element Reverse Surface

[0346] 11: First Obverse-Surface Electrode (Gate Electrode)

[0347] 12: Second Obverse-Surface Electrode (Source Electrode)

[0348] 13: Third Obverse-Surface Electrode

[0349] 14: Fourth Obverse-Surface Electrode

[0350] 15: Reverse-Surface Electrode (Drain Electrode)

[0351] 16: Fifth Obverse-Surface Electrode

[0352] 171, 172, 173, 174: Corner

[0353] 181, 182, 183, 184: Corner

[0354] 191: First Side

[0355] 192: Second Side

[0356] 193: Third Side

[0357] 194: Fourth Side

[0358] 2: Conductive Substrate

[0359] 2A: First Conductive Portion

[0360] 2B: Second Conductive Portion

[0361] 201: Obverse Surface

[0362] 201a: Recessed Portion

[0363] 201b: Recess Edge

[0364] 202: Reverse Surface

[0365] 21: Base Member

[0366] 22: Obverse-Surface Bonding Layer

[0367] 23: Reverse-Surface Bonding Layer

[0368] 3: Supporting Substrate

[0369] 301: Supporting Surface

[0370] 302: Bottom Surface

[0371] 31: Insulating Layer

[0372] 32: First Metal Layer

[0373] 32A: First Portion

[0374] 32B: Second Portion

[0375] 321: First Bonding Layer

[0376] 33: Second Metal Layer

[0377] 41: First Input Terminal

[0378] 411: Input-Side Bonding Surface

[0379] 412: Input-Side Side Surface

[0380] 413: Tip Surface

[0381] 414: Lateral Surface

[0382] 42: Second Input Terminal

[0383] 421: Input-Side Bonding Surface

[0384] 422: Input-Side Side Surface

[0385] 423: Tip Surface

[0386] 424: Lateral Surface

[0387] 43: Third Input Terminal

- [0388] 431: Input-Side Bonding Surface  
 [0389] 432: Input-Side Side Surface  
 [0390] 433: Tip Surface  
 [0391] 434: Lateral Surface  
 [0392] 44: Output Terminal  
 [0393] 441: Output-Side Bonding Surface  
 [0394] 442: Output-Side Side Surface  
 [0395] 443: Tip Surface  
 [0396] 444: Lateral Surface  
 [0397] 45: At least one control terminal  
 [0398] 451: Holder  
 [0399] 452: Metal Pin  
 [0400] 452a: Cushion Member  
 [0401] 459: Conductive Bonding Member  
 [0402] 46A, 46B, 46C, 46D, 46E: First control terminal  
 [0403] 47A, 47B, 47C, 47D: Second control terminal  
 [0404] 5: A control terminal support  
 [0405] 51: Insulating Layer  
 [0406] 52: First Metal Layer  
 [0407] 521: First Portion  
 [0408] 522: Second Portion  
 [0409] 523: Third Portion  
 [0410] 524: Fourth Portion  
 [0411] 525: Fifth Portion  
 [0412] 53: Second Metal Layer  
 [0413] 59: Bonding Member  
 [0414] 6: Conducting Member  
 [0415] 601: First Portion  
 [0416] 61: First Conducting Member  
 [0417] 61h: Opening  
 [0418] 62: Second Conducting Member  
 [0419] 62A: First Portion  
 [0420] 62B: Second Portion  
 [0421] 621: First Wiring Portion  
 [0422] 622: Second Wiring Portion  
 [0423] 623: Third Wiring Portion  
 [0424] 623a: Recessed Area  
 [0425] 623h: Opening  
 [0426] 624: Fourth Wiring Portion  
 [0427] 625: First Band portion  
 [0428] 625a: Protruding Area  
 [0429] 625h: Opening  
 [0430] 626: Second Band portion  
 [0431] 627: First Edge  
 [0432] 628: Second Edge  
 [0433] 63: Opening  
 [0434] 69: Conductive Bonding Member  
 [0435] 71: First Conductive Bonding Member  
 [0436] 711: First Base Layer  
 [0437] 712: First Layer  
 [0438] 713: Second Layer  
 [0439] 72: Second Conductive Bonding Member  
 [0440] 721: Second Base Layer  
 [0441] 722: Third Layer  
 [0442] 723: Fourth Layer  
 [0443] 731: Wire  
 [0444] 731a: First Wire  
 [0445] 731b: Second Wire  
 [0446] 732, 733, 734, 735: Wire  
 [0447] 8: Sealing Resin  
 [0448] 81: Resin Obverse Surface  
 [0449] 82: Resin Reverse Surface  
 [0450] 831, 832: Resin Side Surface  
 [0451] 832a: Recessed Portion  
 [0452] 833, 834: Resin Side Surface  
 [0453] 851: First Protrusion  
 [0454] 851a: First Protruding End Surface  
 [0455] 851b: Recessed Portion  
 [0456] 851c: Inner Wall Surface  
 [0457] 852: Second Protrusion  
 [0458] 86: Resin Void  
 [0459] 861: Resin Void Edge  
 [0460] 87: Resin Member  
 [0461] 88: Resin-filling Portion  
 [0462] 91: Mold  
 [0463] 911: Pressing Pin
1. A semiconductor module comprising:
    - a conductive substrate having an obverse surface facing in one sense of a thickness direction, and a reverse surface facing away from the obverse surface in the thickness direction;
    - a semiconductor element electrically bonded to the obverse surface and having a switching function;
    - a control terminal for controlling the semiconductor element; and
    - a sealing resin having a resin obverse surface facing the same side as the obverse surface, and a resin reverse surface facing an opposite side from the resin obverse surface, the sealing resin covering the conductive substrate, the semiconductor element, and a part of the control terminal,
 wherein the control terminal protrudes from the resin obverse surface, and extends along the thickness direction.
  2. The semiconductor module according to claim 1, wherein the sealing resin has a resin side surface that is connected to the resin obverse surface and the resin reverse surface, and that is flanked by the resin obverse surface and the resin reverse surface in the thickness direction, the semiconductor module is provided with a power supply terminal protruding from the resin side surface, electrically connected to the semiconductor element, and handling power supply voltage, and the power supply terminal has a bonding surface facing in the one sense of the thickness direction.
  3. The semiconductor module according to claim 2, wherein the at least one power supply terminal includes at least one first power supply terminal that receives a first power supply voltage and a second power supply terminal that outputs a second power supply voltage.
  4. The semiconductor module according to claim 1, further comprising a control terminal support that is provided between the obverse surface and the control terminal, and that has an insulating layer.
  5. The semiconductor module according to claim 4, wherein the control terminal support has the insulating layer, a first metal layer stacked on a surface of the insulating layer in one sense of the thickness direction, and a second metal layer stacked on another surface of the insulating layer in another sense the thickness direction and bonded to the conductive substrate to face the obverse surface.
  6. The semiconductor module according to claim 5, wherein the control terminal is bonded to the first metal layer via a conductive bonding member.
  7. The semiconductor module according to claim 6, wherein the semiconductor element has an element obverse surface facing the same side as the obverse

surface, an element reverse surface facing an opposite side from the element obverse surface, and a gate electrode on the element obverse surface, and the gate electrode and the first metal layer are connected to a conductive wire.

**8.** The semiconductor module according to claim **6**, wherein the control terminal includes a conductive tubular holder that is bonded to the first metal layer, and a metal pin pressed into the holder and extending in the thickness direction.

**9.** The semiconductor module according to claim **8**, wherein a part of the holder is exposed from the sealing resin in the one sense of the thickness direction.

**10.** The semiconductor module according to claim **9**, further comprising a resin member bonded to the sealing resin,

wherein the resin member covers a part of the holder that is exposed from the sealing resin, and a part of the metal pin.

**11.** The semiconductor module according to claim **3**, wherein the conductive substrate includes a first conductive portion and a second conductive portion that are spaced apart from each other in a first direction perpendicular to the thickness direction, such that the first conductive portion is offset in one sense of the first direction and the second conductive portion is offset in another sense of the first direction,

the at least one semiconductor element includes a first semiconductor element electrically bonded to the first conductive portion, and a second semiconductor element electrically bonded to the second conductive portion,

the at least one first power supply terminal includes a first input terminal that is offset in the one sense of the first direction relative to the first semiconductor element and connected to the first conductive portion, and a second input terminal that is offset in the one sense of the first direction relative to the first semiconductor element and connected to the second semiconductor element,

the second power supply terminal is an output terminal that is offset in the other sense of the first direction

relative to the second semiconductor element and connected to the second conductive portion,

the at least one control terminal includes a first control terminal for controlling the first semiconductor element and a second control terminal for controlling the second semiconductor element,

the first control terminal is supported by the first conductive portion and provided between the first semiconductor element and each of the first input terminal and the second input terminal in the first direction, and

the second control terminal is supported by the second conductive portion and provided between the second semiconductor element and the output terminal in the first direction.

**12.** The semiconductor module according to claim **11**, further comprising:

a plurality of the first semiconductor elements arranged at intervals in a second direction perpendicular to the thickness direction and the first direction;

a plurality of the first control terminals arranged at intervals in the second direction;

a plurality of the second semiconductor elements arranged at intervals in the second direction; and

a plurality of the second control terminals arranged at intervals in the second direction.

**13.** The semiconductor module according to claim **1**, wherein the sealing resin has a plurality of protrusions, each of which protrudes from the resin obverse surface and has a protruding end surface formed at a tip end thereof, and

the protruding end surfaces of the plurality of protrusions are parallel to the resin obverse surface and on the same plane as the resin obverse surface.

**14.** The semiconductor module according to claim **1**, wherein the control terminal has a cushion member for absorbing a shock caused by vibrations.

**15.** The semiconductor module according to claim **14**, wherein the cushion member is exposed from the sealing resin.

\* \* \* \* \*