

J. C. ARMBRUSTER.  
 KEY ACTUATING ENGINE STARTING CRANK.  
 APPLICATION FILED OCT. 3, 1910.

1,005,496.

Patented Oct. 10, 1911.

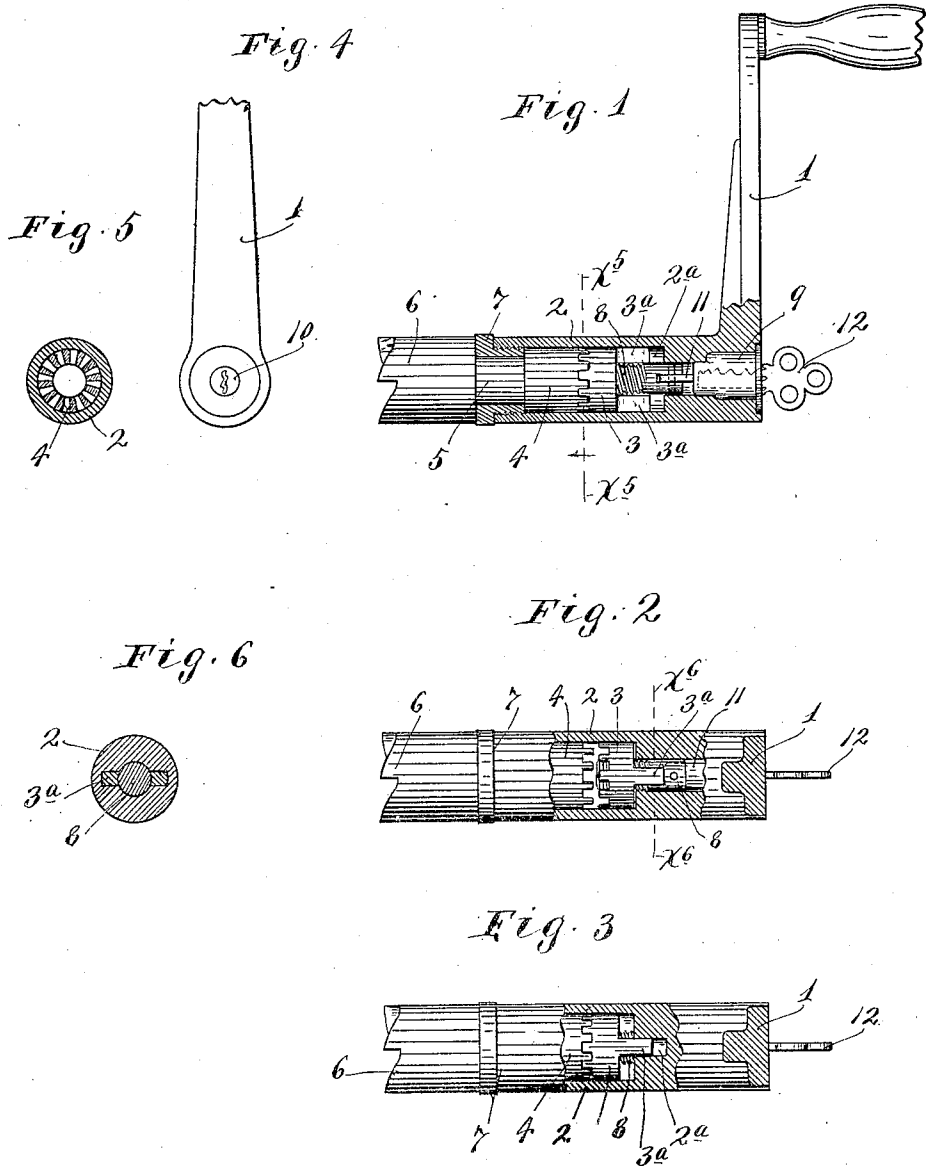

Witnesses.  
 A. H. Opsahl.  
 Harry Opsahl.

Inventor.  
 John C. Armbruster  
 By his Attorneys.  
 Williamson Muehler

# UNITED STATES PATENT OFFICE.

JOHN C. ARMBRUSTER, OF MINNEAPOLIS, MINNESOTA, ASSIGNOR OF ONE-HALF TO  
ERNST A. ARMBRUSTER, OF MINNEAPOLIS, MINNESOTA.

## KEY-ACTUATING ENGINE-STARTING CRANK.

1,005,496.

Specification of Letters Patent. Patented Oct. 10, 1911.

Application filed October 3, 1910. Serial No. 584,966.

To all whom it may concern:

Be it known that I, JOHN C. ARMBRUSTER, a citizen of the United States, residing at Minneapolis, in the county of Hennepin and State of Minnesota, have invented certain new and useful Improvements in Key Actuating Engine-Starting Cranks; and I do hereby declare the following to be a full, clear, and exact description of the invention, such as will enable others skilled in the art to which it appertains to make and use the same.

My invention has for its object to provide a simple and efficient key and lock controlled starting crank for explosive engines and to this end the invention consists of the novel devices and combinations of devices hereinafter described and defined in the claims.

In the accompanying drawings which illustrate the invention, like characters indicate like parts throughout the several views.

Referring to the drawings, Figure 1 is a view partly in elevation and partly in vertical section showing the improved key and lock controlled starting crank, some parts being broken away. Figs. 2 and 3 are views partly in plan and partly in horizontal section showing the improved crank; Fig. 4 is an end elevation of the crank, some parts being broken away; Fig. 5 is a transverse section taken on the line  $x^5 x^5$  of Fig. 1; and Fig. 6 is a transverse section taken on the line  $x^6 x^6$  of Fig. 2.

The lever 1 of the starting crank is provided with a long sleeve-like hub 2 in which is mounted a pair of cooperating clutch members 3 and 4 having interlocking teeth at their abutting faces. The clutch member 4 is provided with a reduced stem portion 5, to the outer end of which is secured a ratchet toothed head 6, the teeth of which are adapted to engage, in the customary way, with ratchet teeth on the shaft of the explosive engine, not shown, and to adapt the said head 6 for such application, it is made hollow. The stem portion 5 is journaled in a sleeve-like bearing 7, the reduced end of which is screwed into the hollow end of the lever hub 2. In this way the clutch member 4 and head 6 are held against endwise movements in respect to the lever hub 2 but are free to rotate in respect thereto.

The clutch member 3 is free for sliding movements within the lever hub 2 but is held

for rotation therewith, preferably by lugs 3<sup>a</sup> on said clutch member 3 that engage in slots 2<sup>a</sup> formed in the interior of the said hub (see particularly Figs. 3 and 6). A rotary clutch operating bolt or stem 8 is rotatively mounted in the outer portion of the lever hub 2, has threaded engagement with the clutch member 3, and itself is held against endwise movements so that by rotation thereof the clutch member 3 may be engaged with or disengaged from the clutch member 4. Preferably, the threads of the bolt 8 are made quadruple and of such pitch that one rotation thereof will be sufficient to move the clutch member 3 from its normal inoperative position shown in Fig. 2 into its operative position shown in Fig. 1, or vice versa. Different kinds of key actuated locks may be employed in connection with this improved crank but I preferably employ the small tumbler lock of well known Yale or Eagle types. The barrel or case 9 of this lock is seated within and rigidly secured to the outer end of the lever hub 2, and its rotating tumbler 10 is flexibly connected by a link 11 to the outer end of the rotary bolt 8. The key for operating the tumbler 10 is indicated by the numeral 12.

As is evident, when the clutch member 3 is disengaged from the clutch member 4, as shown in Fig. 2, the starting crank is rendered absolutely inoperative and cannot possibly be used to start the engine, inasmuch as the lever 1 and its hub will freely rotate in respect to the clutch member 4, and the clutch head 6. When, however, the clutch member 3 is engaged with the clutch member 4, the ratchet head 6 is then rigidly secured for rotation with the lever 1 and the crank is then adapted for use in the usual way to crank the engine.

Obviously, the main purpose of this invention is to provide a simple and efficient means for preventing thieves or unauthorized persons from starting the explosive engine of an automobile, and for this purpose the device has been found highly efficient. It is, however, capable of more general use than that just stated.

Various devices have been devised for preventing automobiles from being stolen or used by persons having no right thereto. So far as I am aware, I am the first to provide a starting crank which is adapted to be rendered operative and inoperative at will by

60

65

70

75

80

85

90

95

100

105

110

means of a key and lock applied to the said crank.

What I claim is:

- 5 1. The combination with a starting crank provided with a hub, of a shaft rotatively mounted in the projected end of said hub, and provided within said hub with a coupling clutch member, and provided outside of said hub with a clutch for connection to  
10 an engine driven shaft, a second coupling clutch member held for rotation but mounted for sliding movements within said crank hub, to connect and disconnect said shaft to said hub, and a key actuated means for moving  
15 the said sliding clutch member, substantially as described.
2. The combination with a starting crank having a hub and provided at its extended end with a movable sleeve and at its crank  
20 end with a key actuated tumbler, a short shaft journaled in the sleeve of said hub and provided at its outer end with a clutch for connection to an engine driven shaft, and provided within the crank hub with a  
5 coupling clutch, a cooperating coupling clutch mounted to rotate with, but for sliding movements within said hub, and a

threaded stem connected to the said latter coupling clutch and the said key actuated tumbler, substantially as described. 30

3. A starting crank for explosive engines comprising a lever having a sleeve-like hub, a clutch member normally free to rotate in said hub but held against endwise movements and provided outside of said lever  
35 hub with a ratchet head, a second clutch member in said hub free for axial movements but held for rotation with said lever hub, an operating bolt having threaded engagement with said axially movable clutch  
40 member, a lock secured in the outer end portion of said lever hub and provided with a key actuated rotary tumbler connected to and operating the said threaded bolt, where-  
45 by the said clutch members may be engaged and disengaged at will by oscillation of said key actuated lock tumbler.

In testimony whereof I affix my signature in presence of two witnesses.

JOHN C. ARMBRUSTER.

Witnesses:

FRANK D. MERCHANT,  
HARRY D. KILGORE.