

(No Model.)

C. GOOCH.
ICE CREAM FREEZER.

No. 525,650.

Patented Sept. 4, 1894.

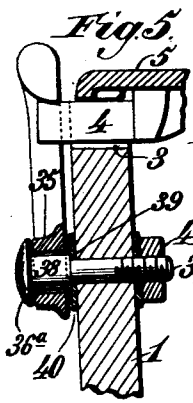
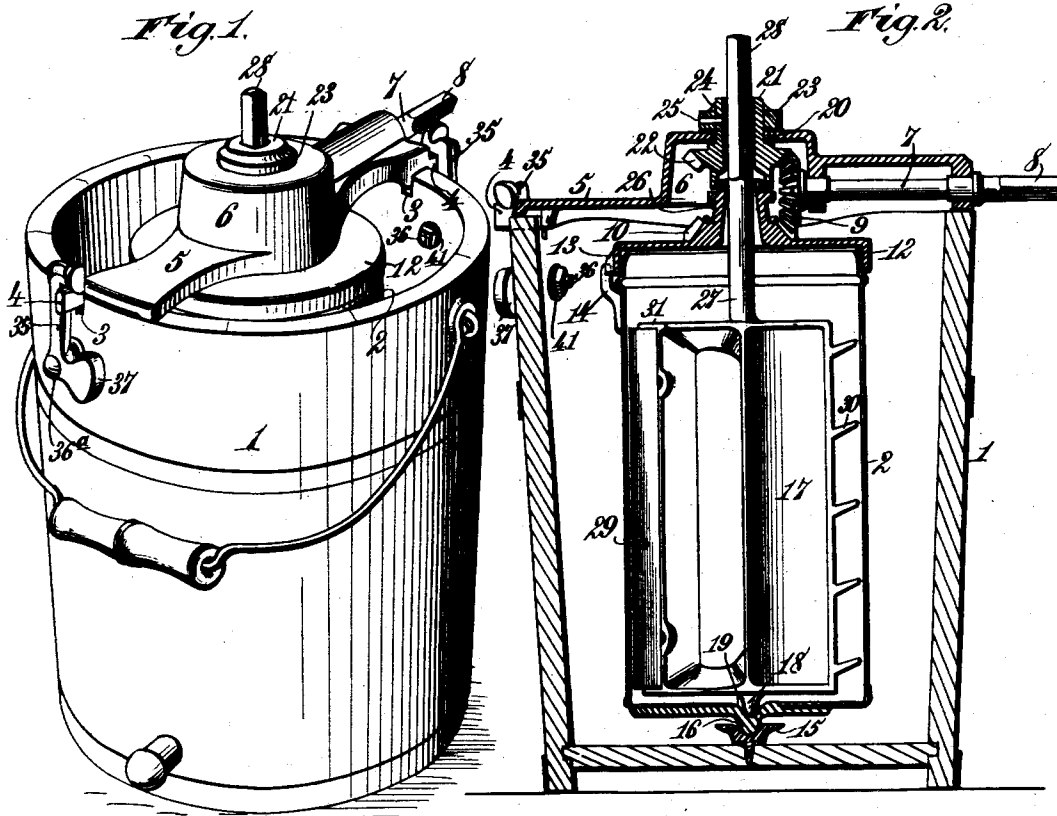

Fig. 3.

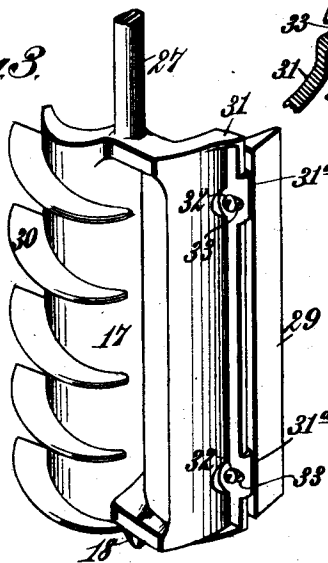
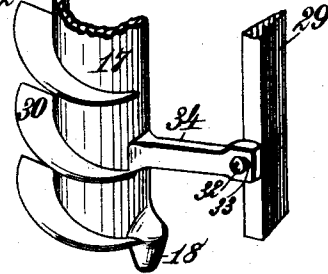

Fig. 6.



Fig. 4.



Witnesses.
Robert G. Mott,
J. W. Rea.

Inventor:
Charles Gooch.
By James L. Norris,
Atty.

UNITED STATES PATENT OFFICE.

CHARLES GOOCH, OF CINCINNATI, OHIO.

ICE-CREAM FREEZER.

SPECIFICATION forming part of Letters Patent No. 525,650, dated September 4, 1894.

Application filed April 3, 1894. Serial No. 506,183. (No model.)

To all whom it may concern:

Be it known that I, CHARLES GOOCH, a citizen of the United States, residing at Cincinnati, in the county of Hamilton and State of Ohio, have invented new and useful Improvements in Ice-Cream Freezers, of which the following is a specification.

This invention relates to ice-cream freezers having a dasher or beater rotated in a can through the medium of gearing arranged in a housing forming part of a cross-bar which is detachably mounted on the tub or refrigerant holder.

The object of my invention is to provide a freezer possessing new and improved features of construction which render the apparatus efficient, convenient and desirable in practicable use.

To accomplish this object my invention consists in the features of construction and the combination or arrangement of parts hereinafter described and claimed, reference being made to the accompanying drawings, in which—

Figure 1 is a perspective view of my improved ice-cream freezer. Fig. 2 is a vertical central sectional view of the same. Fig. 3 is a detail perspective view of the beater or dasher, a portion of the beater-shaft being broken away. Fig. 4 is a detail broken perspective view, showing a modification of the invention. Fig. 5 is a detail sectional view, showing one of the pivot-bolts for the hooks which hold the cross-bar; and Fig. 6 is a detail horizontal sectional view through a portion of the dasher or beater, showing the manner of holding the scraper in position.

In order to enable those skilled in the art to make and use my invention, I will now describe the same in detail, referring to the drawings, wherein—

The numeral 1 indicates a tub or exterior casing which is designed to contain the rotary can 2, and the ice and salt or refrigerant material, which latter is packed into the tub or casing around the can.

The top edge of the tub or casing is provided with diametrically arranged notches 3 designed to receive the longitudinal arms 4 which project from diagonally opposite corners of the cross-bar 5. The cross-bar is a metal casting, formed integral at its central

portion with a dome-shaped housing 6 which is closed and serves to entirely conceal and protect the gearing hereinafter described. 55

The horizontally arranged drive-shaft 7 having an angular portion 8 to receive a crank-handle is journaled on the cross-bar in a plane extending longitudinally between the said diagonally arranged arms 4. The inner end of the drive-shaft 7 is provided with a rigidly attached bevel gear 9, meshing into an annular set of cogs 10 provided on the removable can cover 12. The can-cover is provided with a lateral projection 13 adapted to abut an arm or projection 14 on the can, so that by rotating the shaft 7 the can may be rotated within the tub or casing. 65

The bottom wall of the tub or casing is provided with a stepped bearing 15 to receive and support a central pivot 16 on the bottom of the can. 70

The dasher or beater comprises a broad concavo-convex vertically arranged blade 17 and is designed to rotate in a direction opposite the direction in which the can rotates, and the lower end of the dasher or beater is provided with a pivot 18 adapted to enter a depressed bearing 19 in the bottom of the can. 75

The domed housing 6 is preferably circular in shape and its top wall is provided with a central circular orifice 20, in which is arranged a tubular shaft 21 having at its lower end a rigidly attached main drive-gear 22, and at its upper end a rigidly attached collar 23 which is formed as a separate part and is secured to the tubular shaft after the latter is inserted through the circular opening 20. The collar 23 may be rigidly attached to the tubular shaft 21 by soldering or brazing, as at 24, or by a pin, as at 25, either or both. The collar rests upon the top wall of the domed housing, and thereby supports the tubular shaft and the main drive-gear 22. 80

The central portion of the can-cover 12 is provided with an upwardly projecting sleeve 26 which preferably enters into a circular recess in the lower end of the tubular shaft 21, whereby the parts are maintained in alignment. The beater or dasher-shaft 27 is rigidly secured to the beater or dasher and rises through the sleeve 26 and tubular shaft 21. The upper projecting end 28 of the beater or dasher-shaft is angular to receive a 85 90 95 100

crank-handle, which latter I do not deem it necessary to illustrate. It will be obvious that the crank-handle can be applied either to the angular portion 8 of the horizontal shaft 7, or to the upper projecting end 28 of the beater or dasher-shaft 27; and, since the bore through the tubular-shaft 21 is angular and engages the angular part 28 of the shaft 27, it will be obvious that the beater or dasher will be rotated in one direction, and the freezer can in the opposite direction.

The beater or dasher is provided with a scraper 29 and lifting-blades 30, the latter being arranged in inclined planes on the convex surface of the blade 17 whereby a homogeneous mixture of the contents of the can is obtained, and the ice forming on the inner surface of the can is scraped therefrom. The inclined lifting blades 30, mounted on the solid convex blade 17 virtually form an auger and operate to crush the center of the cream outward and upward and suck down the top cream and air, thus freezing the entire contents simultaneously. The lifting-blades also operate to make the ice flaky and light and produce a superior article, whether this article be sherbet ice or ice-cream. The vertical scraper 29 is designed to have a limited lateral motion, so that it will accommodate itself to the interior of the can and avoid undue friction on the inner surface of the can and pass over inequalities, and yet prevent an undue accumulation of ice on the inner surface of the can. To accomplish this, the beater or dasher is provided with a projecting vertical flanged portion 31 having slots 33 through which pass ordinary wood screws 32 which are screwed directly into the rear edge of the scraper 29. The slots 33 are somewhat larger than the wood screws 32, and consequently the scraper 29 is adapted to oscillate and move inward and outward for the purpose of accommodating itself to the inequalities of the inside of the can. The wood-screws are not screwed up tightly against the flanged portion 31, but are screwed sufficient to attach the scraper, and yet permit sufficient play so that the scraper can slightly oscillate.

The peculiar attachment of the scraper obtains simplicity of construction and economy of manufacture, because the parts do not require to be fitted to one another, or require the employment of skilled labor in assembling them, it only being necessary to pass two ordinary wood screws through the slots 33, which slots do not require to be accurately made, because the screws are designed to fit loosely in them.

In the modification illustrated by Fig. 4, the scraper 29 is designed to be mounted in the manner described on upper and lower flanges or arms 34, forming parts of the beater or dasher. I have only deemed it necessary to exhibit one of the flanges or arms 34, as the other, or uppermost flange or arm, will be in all respects the same as that

shown in the drawings. The wood screws, slots, and scraper, and the manner of attaching the parts shown in Fig. 4 are the same as described with reference to Fig. 3, and therefore further description is not deemed necessary.

The flange portion 31 of the beater or dasher is provided on its outer vertical edge with upper and lower convex bearing surfaces 31^a, through which the slots 33 extend, as best seen in Fig. 6. The convex bearings permit a somewhat close contact of the scraper 29, to render it stable in operation, while facilitating the rocking or oscillating movements thereof. The scraper oscillates on the convex bearing surfaces 31^a, and the latter receive and resist the greater part of the strains which would otherwise be entirely on the scraper and screws, thus rendering the dasher or beater more durable, desirable and satisfactory in use. The flanges or arms 34, are also provided with convex bearing surfaces the same as described above, and as shown in Fig. 6.

By providing the cross-bar 5 with longitudinally projecting arms 4, arranged at diagonally opposite corners, it is possible to apply the cross-bar without exercising any care with reference to placing a particular end of the cross-bar at a particular side of the tub or casing. In the improved construction, the arms 4 will properly engage the vertical notches 3 irrespective of the particular manner in which the cross-bar is applied. The arms 4 project sufficient for the engagement therewith of hooks 35 which are pivoted to the tub or casing, and are provided with balance-weights 37. The pivots of the hooks 35, are each composed of a bolt, clearly shown in Fig. 5, and having a head 36^a and an enlarged cylindrical hub-like portion 38, from which extends the bolt-body 36, of reduced diameter, whereby the annular shoulder 39 is provided. This annular shoulder bears against a metal washer 40, slipped onto the bolt before the latter is inserted through the wall of the tub 1. The inner end of the bolt 36 is screw-threaded to receive a nut 41, by which the bolt is rigidly secured in position. By this construction the bolt can be rigidly clamped to the tub and the hook 35 be held in proper relation to the tub, while permitting the hook to freely turn on the hub-like portion 38.

The weights 37, on the tail ends of the bolts operate to so balance the hooks that their hooked ends will stand toward and near the notches or recesses 3, whereby the hooks are maintained in the best position to be very conveniently and rapidly engaged with the arms 4 when the latter are inserted into the notches or recesses 3. The balance-weights 37 also serve the purpose of preventing the vibrating or shaking movements of the freezer disengaging the hooked ends of the hooks 35 from the arms 4 of the cross-bar. By providing the diametrically opposite hooks 35, the

cross-bar can be dropped vertically in position, and the hooks quickly engaged therewith.

The domed housing of the cross-bar protects and conceals the gearing, and the top wall of the housing serves to sustain the tubular shaft 21 through the medium of the collar 23, and this feature, in connection with the annular set of cogs on the can-cover and the transmitting bevel gear 9 produces driving mechanism which is simple and economical.

I have described and shown the drive-gear 22 integral with the shaft 21, and the collar 23, as a separate part secured to the shaft, but obviously the reverse construction may be adopted; that is, the collar may be integral with the shaft and the gear made separate and attached. This being an obvious construction, it is unnecessary to illustrate the same in the drawings.

Having thus described my invention, what I claim is—

1. The combination with the exterior casing, and the rotary can having an annular cover provided with an annular set of cogs, of a detachable cross-bar having a central domed housing provided in its top wall with a circular orifice, a tubular shaft extending through said orifice and having a bevel gear on its lower end, a collar rigidly secured to the upper end of said shaft and supported by the top wall of the housing, a beater-carrying shaft extending vertically through said gear and tubular shaft and having its upper end adapted to receive a crank-handle, and a bevel-gear meshing with the gear on the shaft, and the cogs on the can-cover, substantially as described.

2. The combination with the exterior casing, and the rotary can having a removable cover provided with an annular set of cogs, of a detachable and reversible cross-bar composed of a metal casting formed integral with a central domed housing having in its top wall a circular orifice, a tubular shaft extending through said orifice and having a bevel-gear on its lower end, a separate collar rigidly secured to the upper end of said shaft and supported by the top wall of the housing, a beater pivoted to the can bottom and having a continuous shaft extending vertically through the tubular shaft and gear and having its upper end adapted to receive a crank-handle, and a bevel-gear meshing with the gear on the tubular-shaft and the cogs on the can-cover and provided with a horizontal shaft having an angular end to receive a crank-handle, substantially as described.

3. The combination of the exterior casing having diametrically arranged vertical notches in its top edge, the detachable and reversible cross-bar provided with drive gear-

ing and having longitudinal rigid arms projecting from diagonally opposite corners of its ends to enter said vertical notches, and two hooks pivoted to the casing in juxtaposition to the said notches for engaging the arms when they lie in the notches, substantially as described.

4. The combination of the exterior casing having diametrically arranged vertical notches in its top edge, the detachable and reversible cross-bar composed of a metal casting formed integral with a central domed housing and longitudinal rigid arms projecting from diagonally opposite corners of its ends to enter said vertical notches, gearing housed in said housing, a drive-shaft journaled on the cross-bar in a plane extending longitudinally between the said projecting arms, and two hooks pivoted to the casing in juxtaposition to said notches for engaging the arms when they lie in the notches, substantially as described.

5. The combination with the exterior casing, and the rotary can arranged therein and having its bottom wall provided with a depressed socket or bearing, of a removable can cover having an annular set of cogs, a detachable and reversible cross-bar composed of a metal casting formed integral with a domed housing having a central circular orifice, a tubular shaft extending through said orifice and having at its lower end a rigidly attached bevel-gear, a separate collar rigidly secured to the upper end of the tubular-shaft and resting on the top wall of the housing, a bevel-gear meshing with the gear on the tubular-shaft and with the cogs on the can-cover and provided with a horizontal shaft having an angular portion to receive a crank-handle, a beater having a pendent pivot fitting the depressed socket or bearing in the can bottom, and a continuous shaft extending from the beater through the tubular shaft and the gear carried thereby and having an angular upper end to receive a crank-handle, substantially as described.

6. The combination with the rotary beater-shaft having a flanged portion provided with horizontal slots 33 and convex bearing surfaces 31^a, of a scraper 29 adapted to bear against and oscillate and move laterally upon said convex bearing surfaces, and wood screws 32 passing through said slots and through the convex bearings into the scraper, substantially as described.

In testimony whereof I have hereunto set my hand in presence of two subscribing witnesses.

CHARLES GOOCH.

Witnesses:

WALLACE BURCH,
SIMEON M. JOHNSON.