



(12) **EUROPEAN PATENT APPLICATION**

(43) Date of publication:
27.09.2006 Bulletin 2006/39

(51) Int Cl.:
A47F 5/02 (2006.01)

(21) Application number: **06111194.4**

(22) Date of filing: **15.03.2006**

(84) Designated Contracting States:
**AT BE BG CH CY CZ DE DK EE ES FI FR GB GR
HU IE IS IT LI LT LU LV MC NL PL PT RO SE SI
SK TR**
Designated Extension States:
AL BA HR MK YU

(72) Inventors:
• **Borsato, Sergio**
31050 Camalo' di Povegliano (IT)
• **Italiano, Calogero Giuseppe**
35037 Teolo (IT)

(30) Priority: **22.03.2005 IT PD20050017 U**

(74) Representative: **Modiano, Micaela Nadia**
Dr. Modiano & Associati S.p.A.
Via Meravigli 16
20123 Milano (IT)

(71) Applicant: **Modoplex S.r.l.**
35030 Rubano (PD) (IT)

(54) **Display with variable configuration**

(57) A display with variable configuration, comprising a supporting element (11) for a ball (12) which is suitable

to enter, with reversible interlocking, a receptacle (13) of an item supporting frame (14) which can rotate thereon about three axes (15, 16, 17).

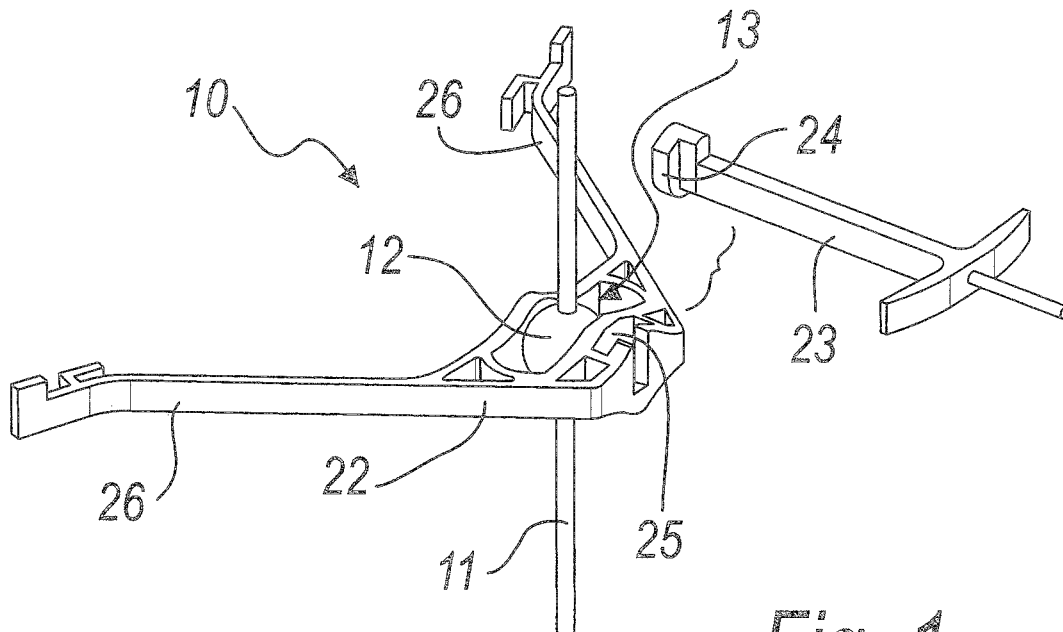

Fig. 1

Description

[0001] The present invention relates to a display with variable configuration.

[0002] All commercial establishments, be they shops, points of sale, display spaces in exhibitions or the like, are provided with displays for the articles on sale.

[0003] These displays can be of the wall-mounted, shelf, or glass-case type and also of the type formed by a column with a plurality of radial arms for supporting lightweight articles, for example eyeglasses.

[0004] Known displays, while being used and appreciated, generally have an inflexible structure, i.e., the supporting surfaces and the supports for the articles on display cannot be tilted or oriented variously in other ways; at the most, column-type displays can turn about their own vertical axis.

[0005] This structural inflexibility often does not allow the display to enhance in the best possible way the article displayed on it, which can have an aesthetic aspect of great importance in a region which is not visible when the article is placed on the display support.

[0006] The aim of the present invention is to provide a variable-configuration display which obviates the drawbacks of known types of display.

[0007] Within this aim, an object of the present invention is to provide a variable-configuration display which is able to give the best possible prominence to the articles displayed thereon.

[0008] Another object of the present invention is to provide a variable-configuration display which is capable of supporting articles having the most disparate shapes and dimensions.

[0009] Another object of the present invention is to provide a variable-configuration display which can be installed easily in any shop window or internal space of a shop, point of sale, exhibition display space, and the like.

[0010] Another object of the present invention is to provide a variable-configuration display which is lightweight, easy to handle and intuitive in installation and therefore can be managed even by personnel lacking particular prior training.

[0011] Another object of the present invention is to provide a variable-configuration display which can be manufactured at low cost with known systems and technologies.

[0012] This aim and these and other objects, which will become better apparent hereinafter, are achieved by a variable-configuration display, characterized in that it is constituted by a supporting element for a ball which is suitable to enter, with reversible interlocking, a receptacle of an item supporting frame which can rotate thereon about three axes.

[0013] Further characteristics and advantages of the invention will become better apparent from the following detailed description of a preferred but not exclusive embodiment thereof, illustrated by way of non-limiting example in the accompanying drawings, wherein:

Figure 1 is a partially exploded perspective view of a display according to the invention;

Figure 2 is a perspective view of a display according to the invention in the assembled condition;

Figure 3 is a front view of a display according to the invention;

Figure 4 is a sectional side view of a detail of a display according to the invention.

[0014] With reference to the figures, a variable-configuration display according to the invention is generally designated by the reference numeral 10.

[0015] The display 10 is constituted by a supporting element 11 for a ball 12, which is suitable to enter, with reversible interlocking, a receptacle 13 of an item supporting frame 14.

[0016] Since it is coupled to the supporting element 11 by means of a ball 12, the frame 14 can rotate about the ball 12 on three axes, respectively 15, 16 and 17.

[0017] The receptacle 13 can be accessed through an elastically deformable frustum-shaped opening 18 for the insertion of the ball 12.

[0018] The receptacle 13 is formed by two facing concavities 19 shaped like a spherical dome, in which the ball 12 is arranged.

[0019] The frustum-shaped opening 18 and the receptacle 13 with spherical domes 19 are mutually contiguous by way of the interposition of an annular extraction-preventing constriction region 20.

[0020] At least one dimension of the transverse cross-section of the constriction region 20 is smaller than the diameter of the ball 12.

[0021] In this manner, the ball 12 is pushed into the frustum-shaped opening 18 and undergoes an elastic deformation in order to make the ball 12 pass.

[0022] Once the ball 12 has passed and is arranged between the two concavities 19, the opening 18 returns to its original configuration and so does the constriction region 20, which by virtue of its dimension which is smaller than the diameter of the ball 12 prevents said ball from disengaging from the receptacle 13.

[0023] The radius of the spherical-dome concavities 19 is smaller than the radius of the ball 12, so that the item supporting frame 14 maintains its configuration on the ball 12 due to the friction produced by interference between the ball 12 and the concavities 19.

[0024] The supporting element 11 is a rod which is suitable to be inserted with interference in a complementarily shaped, transverse hole 21 of the ball 12.

[0025] A same rod 11 can support more than one ball and therefore a plurality of item supporting frames 14.

[0026] The friction between the rod and the hole 21 of the ball allows the ball 12 to remain at the height of the rod at which it has been placed.

[0027] In order to change the position of the ball 12 on the rod 11 it is sufficient to push or pull the ball 12 manually, making it slide along the rod.

[0028] The frame 14 is composed of two detachable

first and second parts 22 and 23.

[0029] A first part 22 is provided with the receptacle 13 and its opening 18 to be associated with the ball 12.

[0030] The second part 23 is designed to support an article to be displayed.

[0031] The first part 22 and the second part 23 are mutually associable by way of reversible fixing means.

[0032] Said reversible fixing means are constituted by an insert 24, which is arranged at a first end of the second part 23 and is suitable to enter a complementarily shaped receptacle 25 which is open on the first part 22.

[0033] The first part 22 has symmetrical protrusions 26 for balancing the weight of the second part 23 and of the article that said part supports.

[0034] The second part 23, by way of the reversible fixing means, can be replaced with another second part which has a different structure but has the same end insert 24 for engagement with the first part 22.

[0035] Therefore, the first part 22 can be equipped selectively with one among a plurality of second parts, each of which is dedicated to supporting a specific article.

[0036] In the accompanying figures, the second part 23 is shaped so as to support eyeglasses.

[0037] The flexibility of the display 10 in allowing to be variously inclined about three axes allows to set up the frame 14 in such a configuration as to enhance in an optimum manner the aspects that best characterize, in terms of visual impact, the eyeglasses being supported.

[0038] Moreover, the frame 14 can be just as easily oriented so as to enhance the article according to the lighting which affects the display.

[0039] The rod 11, in the exemplary embodiment described here, is made of metallic material.

[0040] The ball 12 and the second part 23 of the frame 14 are made of plastics, for example ABS (acronym of Acrylonitrile-Butadiene-Styrene), while the first part 22 is also made of a plastic material, but of the type of Nylon 66 mixed with an elastomer.

[0041] In practice it has been found that the invention thus described solves the drawbacks noted above in known types of display.

[0042] In particular, the present invention provides a variable-configuration display which can give the best possible prominence to the articles displayed thereon.

[0043] Moreover, the present invention provides a variable-configuration display which can carry articles having the most disparate shapes and dimensions.

[0044] Further, the present invention provides a variable-configuration display which can be installed easily in any window or interior of a shop, point of sale, exhibition display space, and the like.

[0045] Conveniently, the present invention provides a variable-configuration display which is lightweight, easy to handle and intuitive to install and therefore can be managed even by personnel lacking particular prior training.

[0046] Moreover, the present invention provides a variable-configuration display which can be manufactured at low cost with known systems and technologies and

can be obtained to a large extent by molding plastic material.

[0047] In practice, the materials employed, so long as they are compatible with the specific use, as well as the dimensions, may be any according to requirements and to the state of the art.

[0048] The disclosures in Italian Utility Model Application No. PD2005U000017 from which this application claims priority are incorporated herein by reference.

[0049] Where technical features mentioned in any claim are followed by reference signs, those reference signs have been included for the sole purpose of increasing the intelligibility of the claims and accordingly such reference signs do not have any limiting effect on the interpretation of each element identified by way of example by such reference signs.

Claims

1. A variable-configuration display, **characterized in that** it is constituted by a supporting element (11) for a ball (12) which is suitable to enter, with reversible interlocking, a receptacle (13) of an item supporting frame (14) which can rotate thereon about three axes (15, 16, 17).
2. The display according to claim 1, **characterized in that** said receptacle (13) can be accessed through an elastically deformable frustum-shaped opening (18) for the insertion of said ball (12), said receptacle (13) being formed by two facing spherical dome-shaped concavities (19), in which said ball (12) is arranged, said frustum-shaped opening (18) and said receptacle (13) with spherical domes (19) being mutually contiguous by way of the interposition of an annular extraction-preventing constriction region (20), in which at least one dimension of its transverse cross-section is smaller than the diameter of the ball (12).
3. The display according to one or more of the preceding claims, **characterized in that** the radius of said spherical dome-shaped concavities (19) is smaller than the radius of the ball (12), so that said item supporting frame (14) maintains its configuration on said ball (12) due to the friction produced by the interference between said ball (12) and the concavities (19).
4. The display according to the preceding claims, **characterized in that** said supporting element (11) is a rod which is suitable to be inserted with interference in a complementarily shaped hole (21) of said ball (12).
5. The display according to one or more of the preceding claims, **characterized in that** said frame (14) is composed of two mutually detachable parts (22, 23),

a first part (22) provided with said receptacle (13) and its opening (18) to be associated with said ball (12) and a second part (23) for supporting an article to be displayed, said first part (22) and said second part (23) being associable by way of reversible fixing means. 5

6. The display according to one or more of the preceding claims, **characterized in that** said reversible fixing means are constituted by an insert (24), which is arranged at one end of said second part (23) and is suitable to enter a complementarily shaped receptacle (25) which opens on said first part (22). 10

7. The display according to one or more of the preceding claims, **characterized in that** said first part (22) has symmetrical protrusions (26) for balancing the weight of the second part (23) and of the article that said second part supports. 15

8. The display according to one or more of the preceding claims, **characterized in that** said second part (23) can be replaced with another second part which has a different structure but is provided with the same end insert (24) for engagement with said first part (22). 20
25

30

35

40

45

50

55

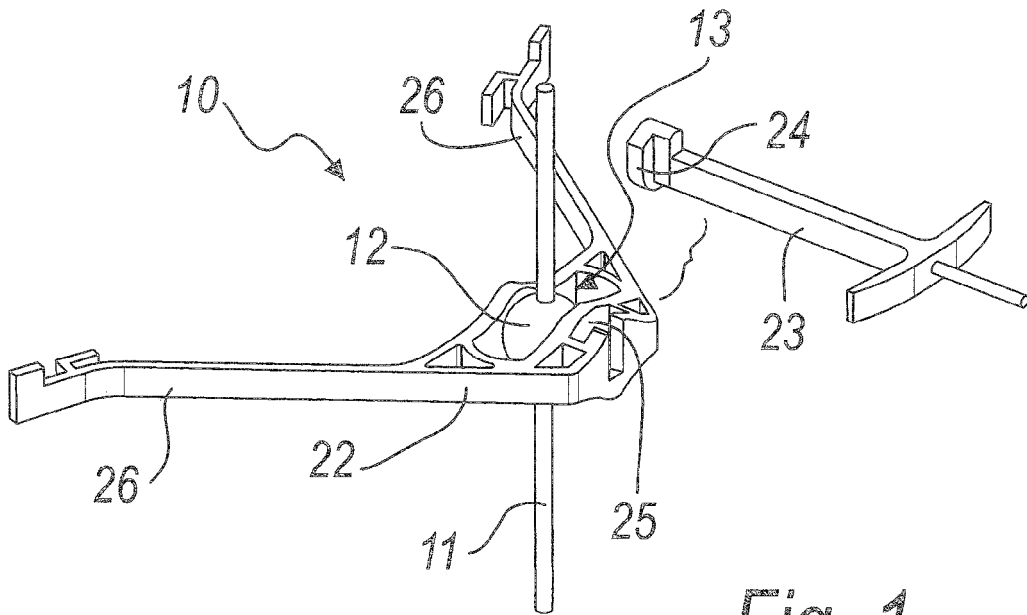

Fig. 1

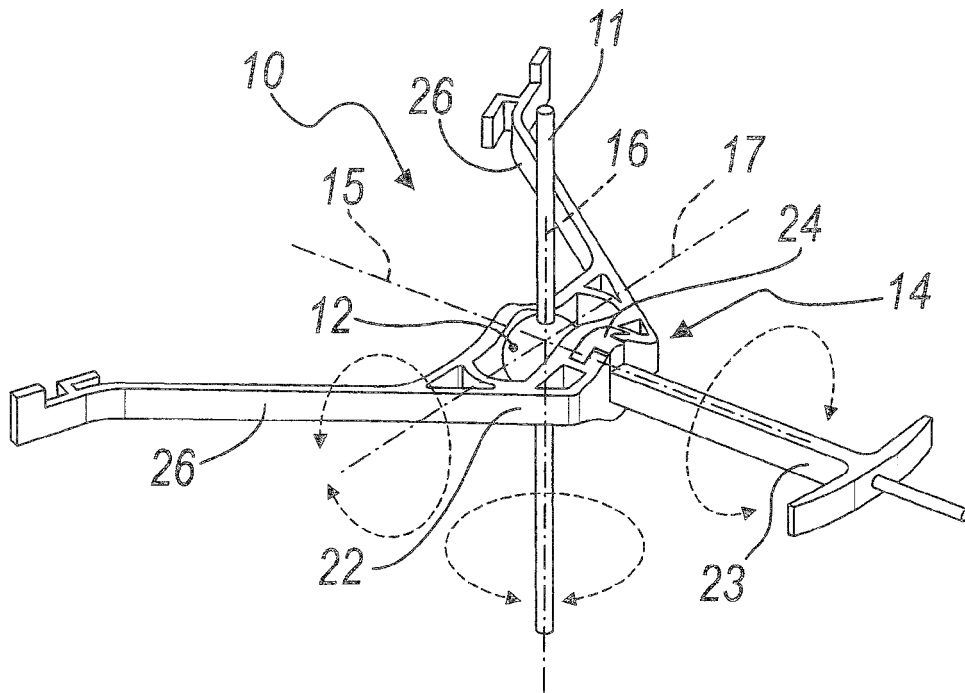

Fig. 2

REFERENCES CITED IN THE DESCRIPTION

This list of references cited by the applicant is for the reader's convenience only. It does not form part of the European patent document. Even though great care has been taken in compiling the references, errors or omissions cannot be excluded and the EPO disclaims all liability in this regard.

Patent documents cited in the description

- IT PD20050017 U [0048]