

(19) **DANMARK**

(10) **DK/EP 3109385 T3**



(12) **Oversættelse af
europæisk patentskrift**

Patent- og
Varemærkestyrelsen

-
- (51) Int.Cl.: **E 05 B 63/24 (2006.01)** **E 05 B 65/00 (2006.01)**
- (45) Oversættelsen bekendtgjort den: **2023-10-23**
- (80) Dato for Den Europæiske Patentmyndigheds bekendtgørelse om meddelelse af patentet: **2023-08-02**
- (86) Europæisk ansøgning nr.: **16176182.0**
- (86) Europæisk indleveringsdag: **2016-06-24**
- (87) Den europæiske ansøgnings publiceringsdag: **2016-12-28**
- (30) Prioritet: **2015-06-26 DE 102015211980**
- (84) Designerede stater: **AL AT BE BG CH CY CZ DE DK EE ES FI FR GB GR HR HU IE IS IT LI LT LU LV MC MK MT NL NO PL PT RO RS SE SI SK SM TR**
- (73) Patenthaver: **Alpha Deuren International BV, Eekhegstraat 3, 6942 GB Didam, Holland**
- (72) Opfinder: **Ruiter, Marc, Matthias Withoosstraat 41, 3812 SR Amersfoort, Holland**
- (74) Fuldmægtig i Danmark: **Larsen & Birkeholm A/S Skandinavisk Patentbureau, Banegårdspladsen 1, 1570 København V, Danmark**
- (54) Benævnelse: **Lukkeindretning til en port med et portblad i en eller flere dele**
- (56) Fremdragne publikationer:
EP-A1- 1 630 326
FR-A1- 2 955 346
US-A1- 2004 212 197
US-A1- 2011 252 844

Locking device in runner profiles for a door with a single-part or multipart door leaf

5

The invention relates to a locking device in runner profiles for a door with a single-part or multipart door leaf, which is movable in lateral runner profiles by rollers.

10 DE 20 2008 002 932 U1 describes a closing element for closing a wall opening with at least one securing device which locks the closing element in the closed position and which consists substantially of a securing bolt and a receptacle which receives the securing bolt, and a locking bar which at least partially penetrates the receptacle and which is configured in a horizontally displaceable and spring-loaded manner, wherein in the closed position the locking bar interacts with the securing bolt such that the closed
15 position can be undone only through a mechanical unlatching device fastened into or onto the locking element.

DE 101 24 359 C1 discloses a swing-up folding door for garages or the like having a door leaf which consists of two hinged-together, approximately equal-sized door leaf halves,
20 the upper door leaf half of which, at its upper edge above the door lintel, is pivotably mounted on a lintel frame, and the lower door leaf half of which, at its lower edge, is vertically movable, with laterally protruding rollers in running rails, out of a closed position in which the two door leaf halves are situated in one plane into an open position in which the two door leaf halves, folded against one another, protrude approximately horizontally.
25 A lock bar of a conventional door lock is displaceably mounted, in order to retract the initiating opening movement, firstly by locking elements actuated by, e.g. via Bowden cables or the like, out of its locking position, in order to then raise the door.

A multiple locking system for a door, which is actuated by a central lock, is depicted by
30 US 1,693,481.

DE 10 2008 013 685 A1 discloses a securing device and a securing method for a door, in which the door leaf can be locked in a closed position by means of the locking device and the locking device, in a locking position, can be moved relative to the switching apparatus
35 by means of the door leaf, such that a switching pulse is generated when the door leaf is moved. Just solely through the movement of the door leaf, a switching apparatus, for example, will trigger an opening process. In this case, the securing device functions only

when a switching pulse is generated, which occurs as result when the locking device or door is locked.

5 Through EP 1 630 326 A1, there is known a device for locking a locking construction of a door, in which a mobile component can be moved relative to a frame between an open and a closed position. In this case, a locking bolt element is mounted in a mobile manner on the component or the frame and a latching element, which is fixedly attached at least in a locking position and which serves the purpose of locking, is present on the frame or the component. This device is intended to increase safety against burglary.

10

The objective of the invention consists in providing a locking device for a single-part or multipart door leaf which is movable in lateral runner profiles which can be integrated, in a manipulation-proof manner, in lateral runner profiles and furthermore requires no additional room or space requirement. Such a locking device is intended to be useable
15 not only in the closed position of the door leaf, but rather also in open positions.

The objective of the invention is achieved through the features of Claim 1. The content of the subordinate claims is a further configuration of the idea according to the invention.

20 The description below relates to a door configured out of several hinged-together door elements, as found in sectional doors, for example. However, the inventive locking device can also be employed in single-part door leaves.

The inventive locking device, in a first preferred embodiment, is divided into a stationary
25 and a movable part. The stationary part is arranged inside at least one runner profile for the door leaf, with the door leaf being guided in runner profiles on both sides. The rollers, which are connected to the individual hinged-together door elements, dip into the runner profiles. Here, the planar locking plate is configured such that, at its ends, it is equipped with inclines which point in the longitudinal direction of the runner profile. Such a locking
30 plate comprises a retaining member which is mounted in a mobile manner and which contains a locking bolt receptacle. The rotatable retaining member is mounted inside the locking plate and is thus stressed by at least one spring element. The retaining member, in its rest position, protrudes partially out of the locking plate such that the locking bolt receptacle is suitable to receive a locking bolt, which is a component of the movable part,
35 in a locking position. The locking position need include not only the closed position of the door leaf, but rather can be implemented in any desired position of the door leaf, as the description below will make clear.

A locking bolt member, which is preferably attached to the movable door element that is proximate to the floor, interacts with the locking plate's design which is arranged to be stationary. The locking bolt member is a component which comprises a protruding rigid locking bolt. This locking bolt is contacted by the locking bolt receptacle when the locking plate automatically passes through the retaining member which projects into the path of movement of the locking bolt. The locking bolt thereby comes to be in the locking bolt receptacle of the locking plate. As a result, the door is automatically securely locked, for example in its closed position. It should be noted here that the combination and the interaction between the locking bolt member, with its rigid locking bolt, and the stationary locking plate can also be arranged, via the retaining member, in any position inside the runner profiles, in multiple implementations. In addition to a so-called ventilation position, these can also be a partially opened position or different opened positions of the door leaf.

Since the locking plate is arranged inside at least one, and preferably in both, runner profiles, it is also possible to use a wide variety of profile types. In a preferred embodiment, a so-called J-profile is suitable. However, C-profiles can also be used.

The locking member is preferably mounted on a base plate and thus simultaneously assumes partial supporting and connection with regard to the relevant door element for the rollers. One roller in each case is arranged at each end of the elongated design of the locking bolt member. The rollers each have a roller axle, which is mounted in a roller bearing or fitting which is connected to the door element. It is possible here that the fitting simultaneously has two receptacles for roller axles which are arranged spaced apart from one another. However, it is also possible that, in the case of a design having two adjacent door elements, for example, one fitting element is assigned respectively, such that the locking bolt member can virtually be divided into two door elements via the roller axles. In this case, the roller axles are, in the horizontal direction, freely mobile in the fitting, which is achieved through adjusted play. It is thus possible to balance tolerances between the door leaf and the runner profiles during the opening and closing processes of the door without any problems.

In order to get the door out of the locking position, this can be accomplished through a wide variety of manipulations of a purely mechanical or electromechanical form. For this purpose, in a purely mechanical design, it is possible to use a lock or a handle in the closed position of the door leaf. By actuating the lock, the rotational movement is transmitted onto the locking device via a transmission element. For example, by means of

a triggering element in the form of a Bowden cable, it is possible to exert, onto a disengaging element assigned to the locking bolt member, a force which ensures that the retaining member is pushed back into the locking plate by the disengaging element. This has the consequence that the locking bolt which previously engages inside the retaining member is released. The position of the door can then be altered.

In the lock unit, in order to release the locking position, it is preferably also possible to opt for a construction which can implement a retaining member actuation which can equally be performed inside and outside of the building.

Instead of the triggering element, it is also possible to use a lever mechanism to apply pressure onto the retaining member in the locking plate.

In a further preferred embodiment, it is also possible for electromechanical mechanisms to be used, which, for example through a Start command for the drive motor of the door, cause the locked position to be released.

Further advantages, features and possible applications of the present invention emerge from the following description in connection with the exemplary embodiments depicted in the drawings, in which not all figures show the locking plate's bevel according to the invention.

The terms used in the list of reference numbers stated below, and the associated reference numbers, are used in the description, claims and drawings. In the drawings:

- Fig. 1 represents a view onto an inside of a door element, with a runner profile depicted on one side and an arrangement of a locking device on the inside;
- Fig. 2 represents the same as Fig. 1, but seen from the outside;
- Fig. 3 represents an inner lock unit with a triggering element for the locking device;
- Fig. 4 represents the same as Fig. 3, but omitting the runner profile in a perspective depiction;
- Fig. 5 represents the locking device in connection with a roller bearing;
- Fig. 6 represents an individual depiction of the movable part of the locking device in a perspective depiction;
- Fig. 7 represents a front view of the movable part of the locking device;
- Fig. 8 represents an individual depiction of a possible disengaging element;
- Fig. 9 represents a depiction of the stationary part of the locking device in a perspective

depiction;

Fig. 10 represents the same as Fig. 9, but in a front view;

Fig. 11 represents the use of the stationary part of the locking device inside a runner profile;

5 Fig. 12 represents the same as Fig. 1, but in a modified design of a lock unit and trigger mechanics;

Fig.13 represents a perspective depiction of the connection between the lock unit according to Fig. 12 and the locking device;

Fig. 14 represents a cutout depiction of the locking device with modified trigger levers;

10 Fig. 15 represents the same as Fig. 14 but in a perspective depiction.

In a first preferred embodiment, the locking device 1 substantially consists of a movable part that should be attributed to a movable door element 3, and a stationary part that is arranged inside a runner profile 2 in a stationary manner. Fig. 1 shows the door element
15 3, which belongs to a door which is movable in the lateral runner profiles 2 by means of rollers 16, 17. The runner profile 2 is fastened to a stationary fastening element 4, preferably in the form of a border or a frame. The depiction from Fig. 1 shows the door element 3 from the inside. Here, a lock unit 6 has been depicted in which a profile cylinder 8 and a handle 34 are shown. It is possible to bring the locking device 1 out of its
20 locking position both by the profile cylinder 8 and by the handle 34. This is possible by a triggering element 7, for example, which acts on a mobile part of the locking device 1. Furthermore, on the door element 3 there has been depicted a roller bearing in a fitting 5, in which a roller axle 10 is mounted.

25 Fig. 2 shows the same door element 3 but from the outside, in which a lock unit 13 is depicted from outside. The profile cylinder 8 has also been reflected inside the lock unit 13.

The two-part structure of the locking device 1 is illustrated by Fig. 3. The triggering
30 element 7 is fed through via a transmission member 12 and mounted in a base plate 14. The roller axles 10 and 11 are simultaneously mounted in the base plate 14, with this part of the locking device 1 being movable by the attached door element 3. A stationary part, in the form of a locking plate 18, is operatively connected to the movable part. In this exemplary embodiment, the runner profile 2, which is preferably configured as a J-profile,
35 is connected to the fastening element 4. The inner part of the lock unit 6 has been depicted at the left end of the triggering element 7. The entire locking device 1 is depicted in connection with the lock units 6 and 13 by the perspective depiction according to Fig.

4.

That part of the locking apparatus 1 which is arranged in a stationary manner substantially consists of the locking plate 18, in which a retaining member 21 is arranged in a mobile manner inside a recess 31. Here, the retaining member 21 has a locking bolt receptacle 22 for a locking bolt 15 which is assigned to the stationary part of the locking device 1. The retaining member 21 is arranged in a mobile manner inside the recess 31 via an axle 33, according to Fig. 9. The retaining member 21 is stressed by spring elements 32 such that the retaining member 21, in its normal position, protrudes from the locking plate 18 such that it can interact, in the closed position, with the second part of the locking device 1, namely the locking bolt 15. The locking plate 18 has bevels 19 at its upper and lower ends respectively, and contains fastening bores 30, in order to be able to set a precise alignment inside the runner profile 2 for the desired locking position. Fig. 10 shows how the retaining member 21, in its home position, protrudes out of the locking plate 18.

In the locking position, the immobile locking bolt 15 interacts with the locking plate 18. A position in which the locking bolt 15 is located outside in the locking position, can be seen from Fig. 4.

20

The entire locking device 1 with the movable part and the stationary part can be seen in Fig. 5. The locking plate 18 with the retaining member 21 pivoted out in the locking position is visible on the right side. The locking bolt 15, which is part of a locking bolt member 23, engages in the locking bolt receptacle 22. As a result, it becomes clear that the locking bolt 15, in its position, has no mobile part per se and therefore is rigid. The locking bolt member 23 with the locking bolt 15 is fastened onto the base plate 14. The roller axles 10, 11 are also mounted inside the locking bolt member 23. In this depiction, the roller bearing 5 is shown in connection with a fitting 5, in which the roller axle 10 enters inside the fitting 5 with play. As a result, it is possible that, when the door element 3 moves, the movable part of the locking device 1 is inevitably carried along via the roller axles 10 and 11. The rollers 16, 17 are rail-guided inside the runner profile 2.

The structure of the movable part of the locking device 1 can be seen in particular from Figures 6 and 7, in respective individual depictions. It becomes clear here that the locking bolt member 23 is molded onto the locking bolt 15. This means that the locking bolt 15 as such cannot perform any movement, in particular any horizontal movement. To bring the retaining member 21 out of a locked position, it is necessary for the retaining member 21

35

to retreat relative to a surface 20 of the locking plate 18, or rather to be situated on the same level of the surface 20, in order to achieve a release of the locking position when the locking bolt member 23 passes by the retaining member 21.

- 5 In the case of a design which works in a purely mechanical manner, the position of the retaining member 21 can be altered only through the triggering element 7. In this case, the triggering element 7 acts on a disengaging element 26. Such a disengaging element 26 can be seen from Fig. 8. Via a bore 27, which is arranged at one end of the disengaging element 26, there virtually arises a one-armed lever which can be pivoted via
- 10 a point of rotation of the bore 27 and which has a protrusion 28 at the other end. In the exemplary embodiment from Fig. 6 and 7, this protrusion 28 penetrates the locking bolt member 23 and is thus mounted in the locking bolt member 23 via the bore 27. If the triggering element 7 now exerts a pressure force onto a pressure point 29 of the disengaging element 26, then the disengaging element 26 pivots in the direction of the
- 15 locking plate 18 and as a result brings the protrusion 28 to bear on the surface of the retaining member 21 and, against the spring force of the spring elements 32, presses the retaining member 21 into the locking plate 18. In a reverse manner, it is conceivable to stress the disengaging element 26 with a pulling force to free the triggering element 7.
- 20 Fig. 11 depicts the arrangement of the locking plate 18 inside the runner profile 2. Here, the runner profile 2 has been configured as a J-profile. If it is configured as a C-profile, it is necessary to make the rollers 16, 17, which are otherwise used in this form with a spherical running surface, smooth or rather with a projection.
- 25 Figures 12 to 15 show a modified design of the locking device 1. Here there has been depicted a lock interior unit 35 to which the handle 34 is connected. When the handle 34 is actuated, a transmission member 36 acts on a transmission lever 37 such that, when pressure is exerted, the disengaging element 26 presses, by its protrusion 28, against the retaining member 21. Here, the design of the disengaging element 26 has been used in a
- 30 modified design, as can be seen in Fig. 15, furthermore, the locking bolt member 23 has not been depicted, but it can be seen in Fig. 14.

As the described preferred designs make clear, the locking device 1 can be used in the closed position of the door leaf, for example. However, it is also possible to additionally use such a locking device 1 in the open position. In order to be able to perform unlocking after a locking, when the door leaf is in the open position, this can be realised via a mechanical mechanism or an electromechanical device. Furthermore, intermediate

positions of locking positions in different heights, depending on the use of the door, are possible. Such a design of the locking device 1 can be used in doors configured as sectional doors with several hinged-together door elements. It is likewise possible to use it with spiral doors or roller doors. Due to the fact that the locking device 1 is not visible from outside, it is possible to rule out manipulations, since the locking plate 18 is embedded securely into the runner profile 2 by the retaining member 21.

List of reference numbers

	1	locking apparatus
	2	runner profile
5	3	door element
	4	fastening element
	5	roller bearing / fitting
	6	lock unit, interior
	7	triggering element
10	8	profile cylinder
	10	roller axle
	11	roller axle
	12	transmission member
	13	lock unit, exterior
15	14	base plate
	15	locking bolt
	16	roller
	17	roller
	18	locking plate
20	19	bevel
	20	surface
	21	retaining member
	22	locking bolt receptacle
	23	locking bolt member
25	26	disengaging element
	27	bore
	28	protrusion
	29	pressure point
	30	fastening bore
30	31	recess
	32	spring element
	33	axle
	34	handle
	35	lock interior unit
35	36	transmission member
	37	transmission lever

P A T E N T K R A V

1. Lukkeindretning (1) til en port i en eller flere dele med mindst et flytbart portelement (3), som kan flyttes i laterale løbeprofiler (2) ved hjælp af løberuller (16, 17), hvor lukkeindretningen (1) består i det væsentlige af et langs løbeprofilet (2) flytbart låserigelstykke (23), som er placeret på mindst et portelement (3) og omfatter en stiv låserigel (15), og af en med låseriglen (15) samvirkende, stationær flad låseplade (18), som skal placeres i løbeprofilet (2), og som på sine ender er forsynet med affasninger (19), som peger i længderetning, og at låsepladen (18) har tilknyttet et bevægeligt lejret holdestykke (21) med et låserigeloptageelement (22), hvorved holdestykket (21) i sin hvileposition rager således ud af låsepladen (18), at låserigeloptageelementet (22) er egnet til at optage låseriglen (15) i en låseposition.
2. Lukkeindretning ifølge krav 1, **kendetegnet ved, at** holdestykket (21) er lejret drejeligt inde i låsepladen (18) via en aksel (33) og er belastet ved hjælp af mindst et fjederelement (32) således, at holdestykket (21) i sin hvileposition rager delvist ud af låsepladen (18).
3. Lukkeindretning ifølge krav 1, **kendetegnet ved, at** løbeprofilet (2) er udformet som J-profil eller C-profil, hvor løberullerne (16, 17) på sine løbeflader er udformet hvælvet eller rektangulært eller rektangulært med en ansats.
4. Lukkeindretning ifølge kravene 1 og 3, **kendetegnet ved, at** låserigelstykket (23) gennemtrænges af rulleaksler (10, 11), som på den ene ende bærer løberullerne (16, 17) og på den anden ende griber ind i rullelejer (5), som er fastgjort på hosliggende portelementer (3) således, at rulleakslerne (10, 11) er lejret bevægeligt i rullelejerne (5) i horisontal retning.
5. Lukkeindretning ifølge kravene 1 og 4, **kendetegnet ved, at** der inde i eller uden for låserigelstykket (23) bevægeligt er lejret et udrykkelement (26), som kan indvirke på holdestykket (21), fortrinsvis ved hjælp af et fremspring (28).

6. Lukkeindretning ifølge krav 5, **kendetegnet ved, at** udrykkerelementet (26) kan ændres i sin position middelbart eller umiddelbart ved hjælp af en lås (6, 35) eller et håndgreb (34) eller en mekanisk mekanisme eller en elektromekanisk indretning.
- 5 7. Lukkeindretning ifølge et af de foregående krav, **kendetegnet ved, at** låserigelstykket (23) er knyttet til en grundplade (14), som samtidigt danner et afstandselement og lejring for løberullerne (16, 17).
- 10 8. Lukkeindretning ifølge kravene 1 og 6, **kendetegnet ved, at** låsen (6, 35) og håndgrebet (34) valgfrit kan betjenes fra indersiden såvel som fra ydersiden af portelementet (3).
- 15 9. Lukkeindretning ifølge krav 6, **kendetegnet ved, at** den elektromekaniske indretning er udformet som elektromagnet.
- 20 10. Lukkeindretning ifølge et af kravene 1 eller 2, **kendetegnet ved, at** den omfatter et mangefold antal låseplader (18), således at låsepladen (18) kan forefindes i løbeprofilet (2) i et mangefold antal, fortrinsvis i portens lukkede stilling og/eller åbne stilling eller i en foretrukket udførelse i mellemposition mellem den åbne stilling og den lukkede stilling.
- 25 11. Lukkeindretning ifølge et af de foregående krav, **kendetegnet ved, at** porten i den lukkede stilling altid er låst ved hjælp af lukkeindretningen 1.
- 30 12. Lukkeindretning ifølge krav 5 og 6, **kendetegnet ved, at** udrykkerelementet (26) er fjederbelastet således, at fremspringet (28) i sin hvileposition ligger inde i låserigelstykket (23), og at fremspringet (28) ved en trykpåvirkning på udrykkerelementet (26) kan trykke holdestykket (21) ud af låsepositionen med låseriglen (15).
13. Lukkeindretning ifølge et af de foregående krav, **kendetegnet ved, at** lukkeindretningen (1) kan eftermonteres på porten.

14. Port i en eller flere dele med en lukkeindretning ifølge de foregående krav, **kendetegnet ved, at** porten er udformet som sektions- eller spiralport eller rulleport med flere indbyrdes hængslet forbundne portelementer (3).

5 15. Port i en eller flere dele ifølge krav 14, **kendetegnet ved, at** porten er udstyret med en gangdør.

10 16. Sektionsport med flere indbyrdes hængslet forbundne portelementer (3), som er flytbare i laterale løbeprofiler (2) ved hjælp af løberuller (16, 17), med en mindst i sektionsportens lukkede stilling automatisk låsning ved hjælp af en lukkeindretning 1 ifølge et eller flere af de foregående krav.

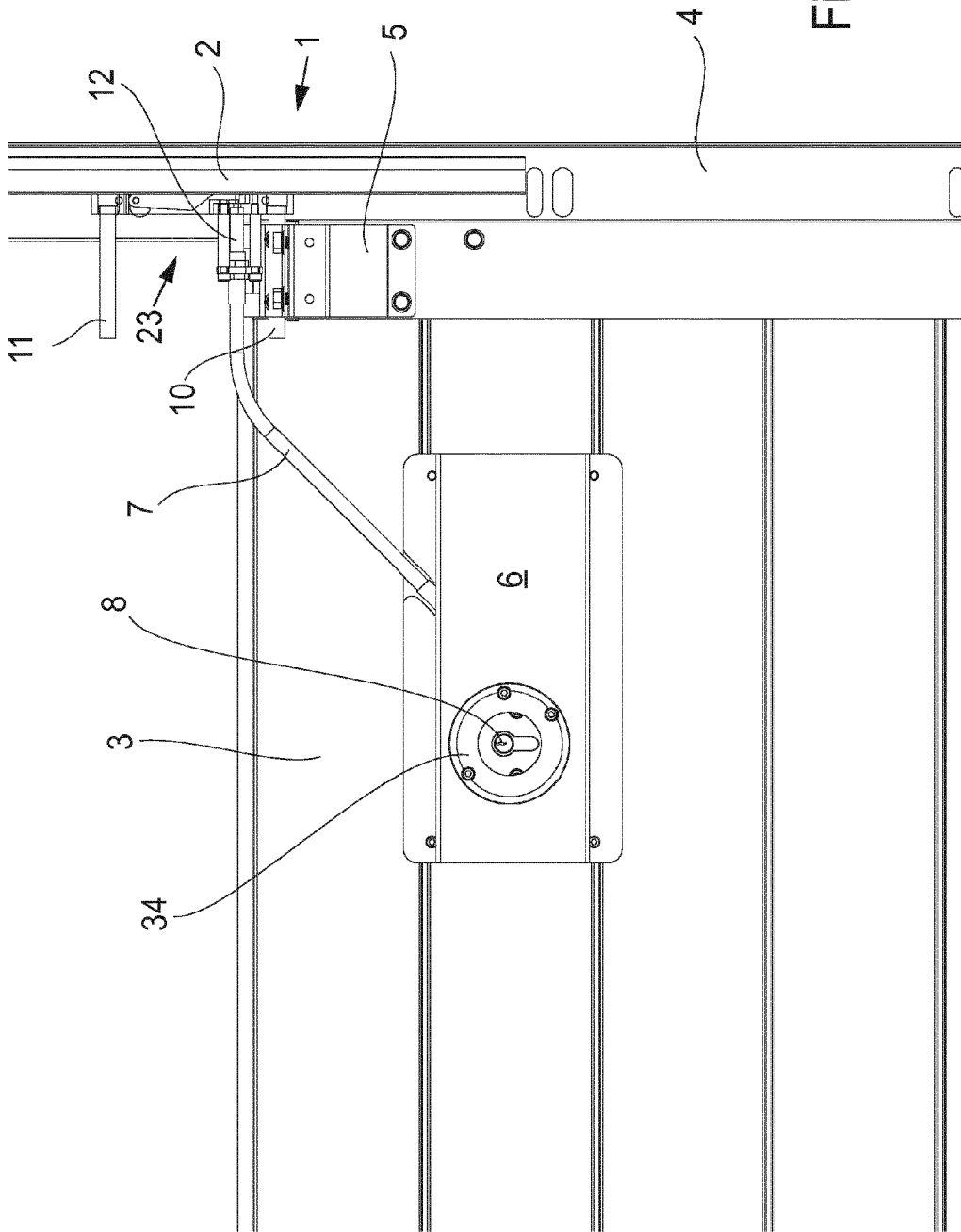

Fig. 1

Fig. 2

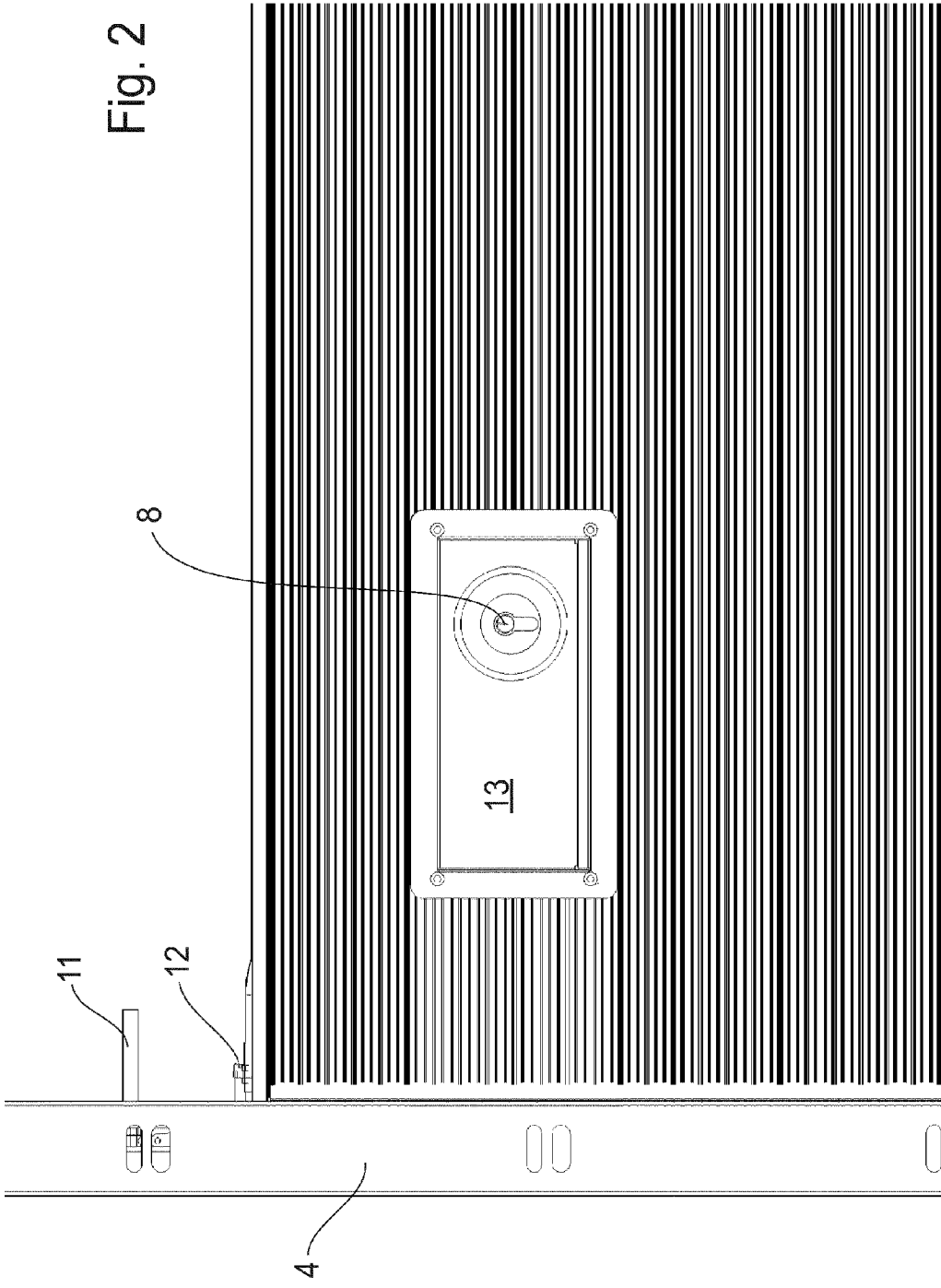
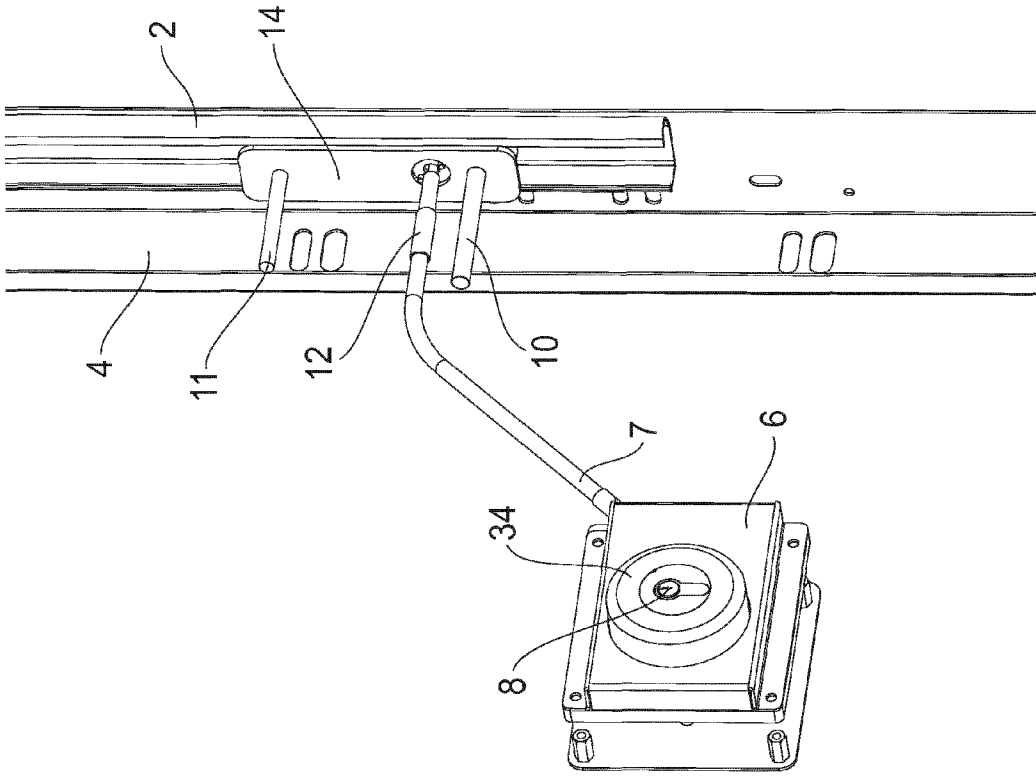

Fig. 3



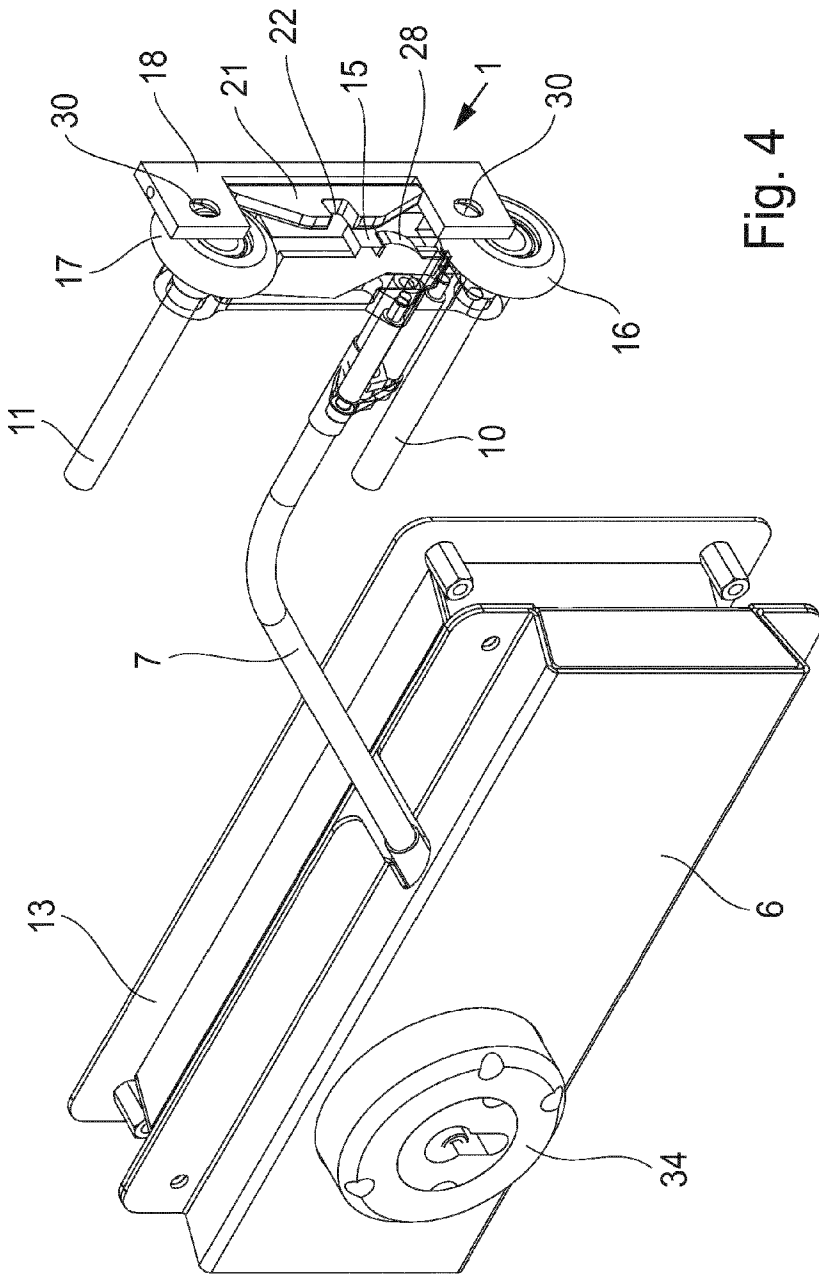

Fig. 4

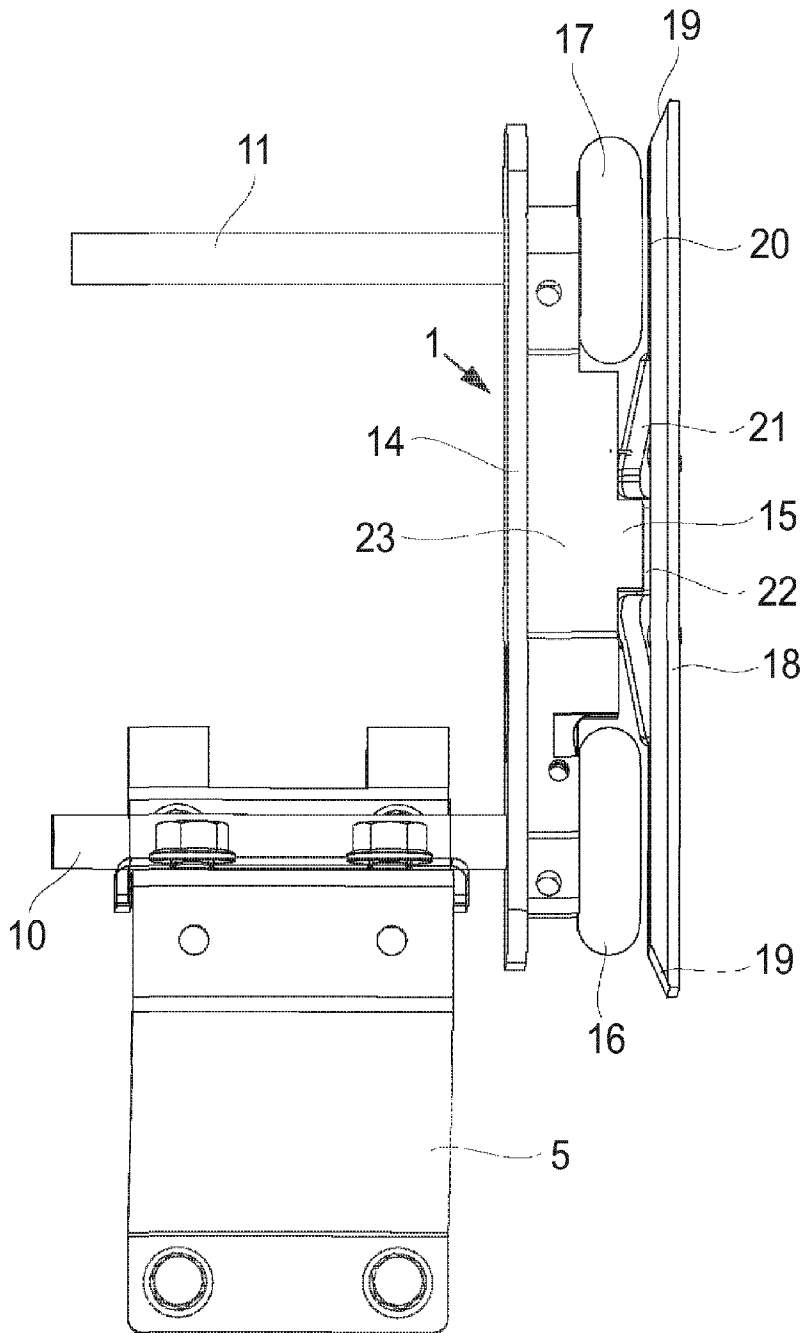

Fig. 5

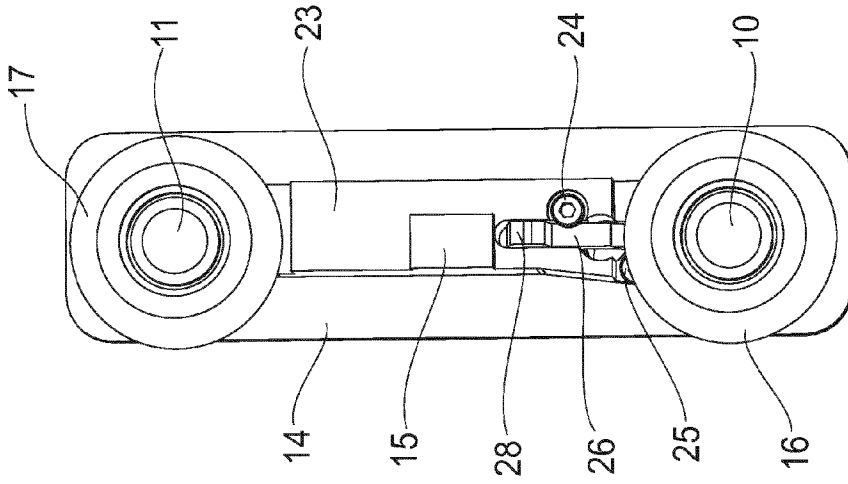

Fig. 7

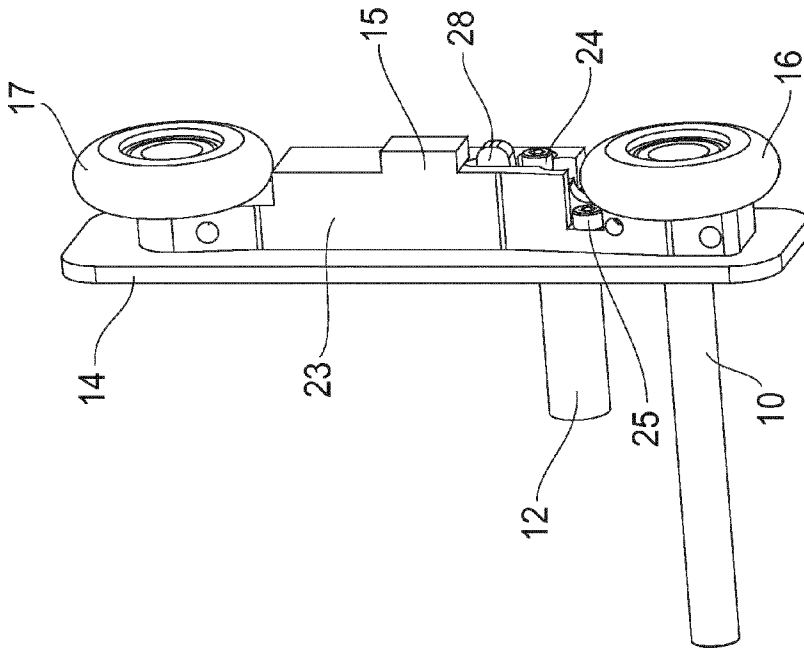

Fig. 6

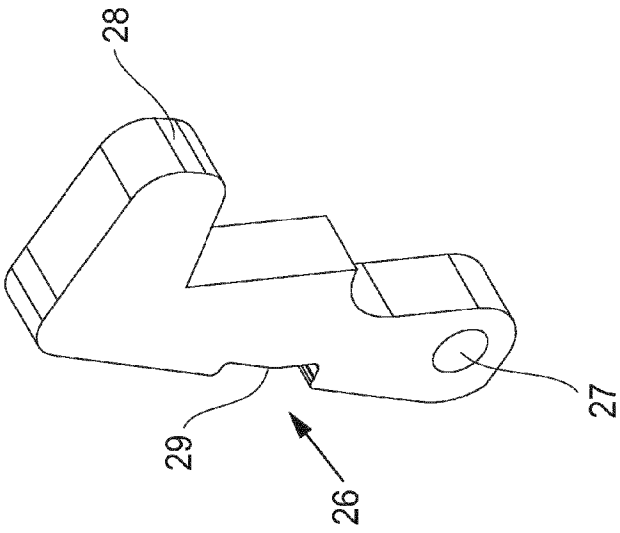

Fig. 8

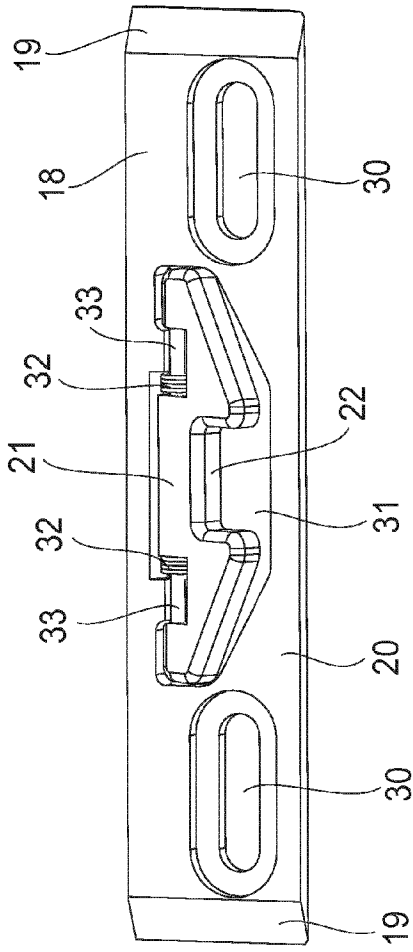

Fig. 9

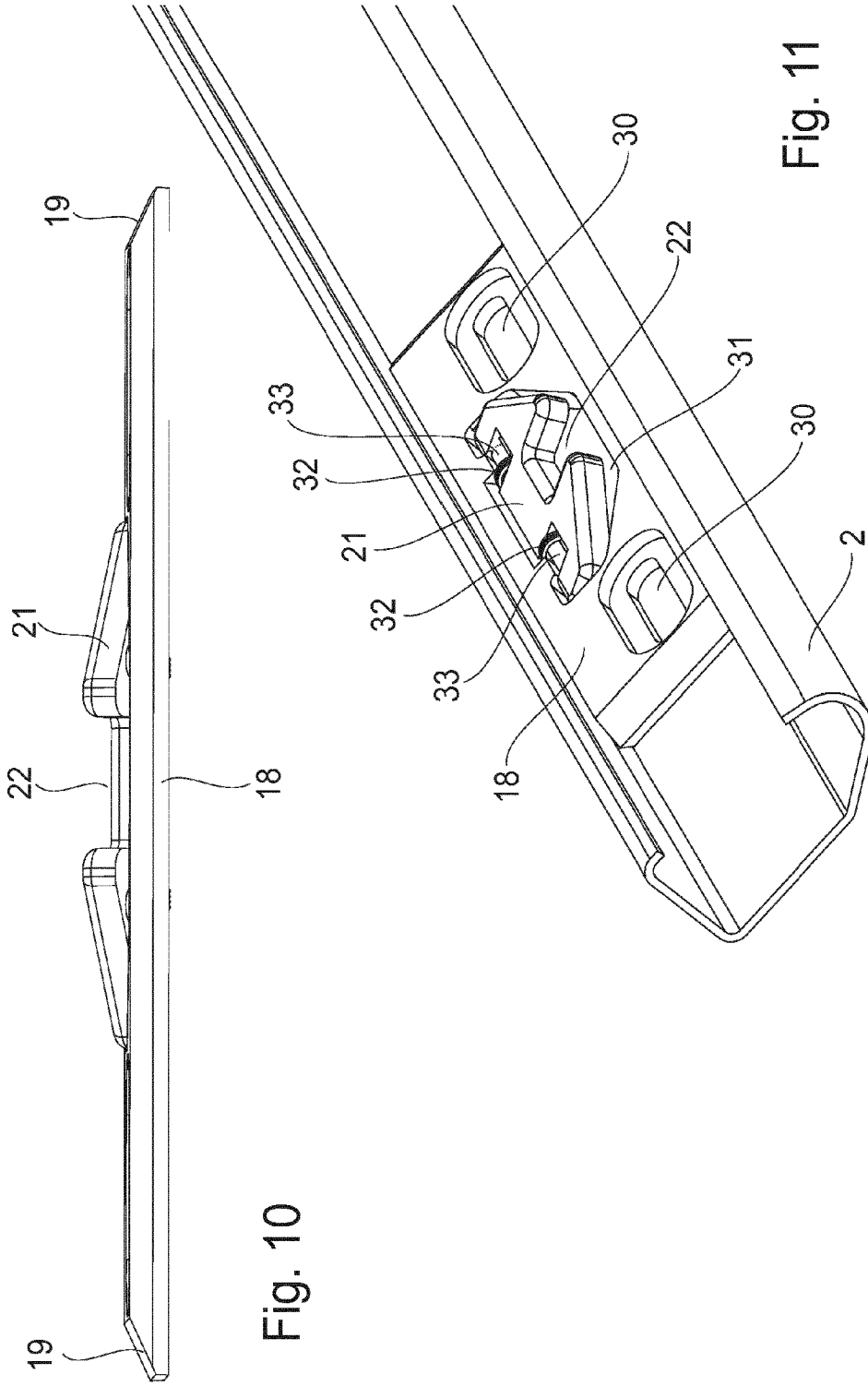

Fig. 10

Fig. 11

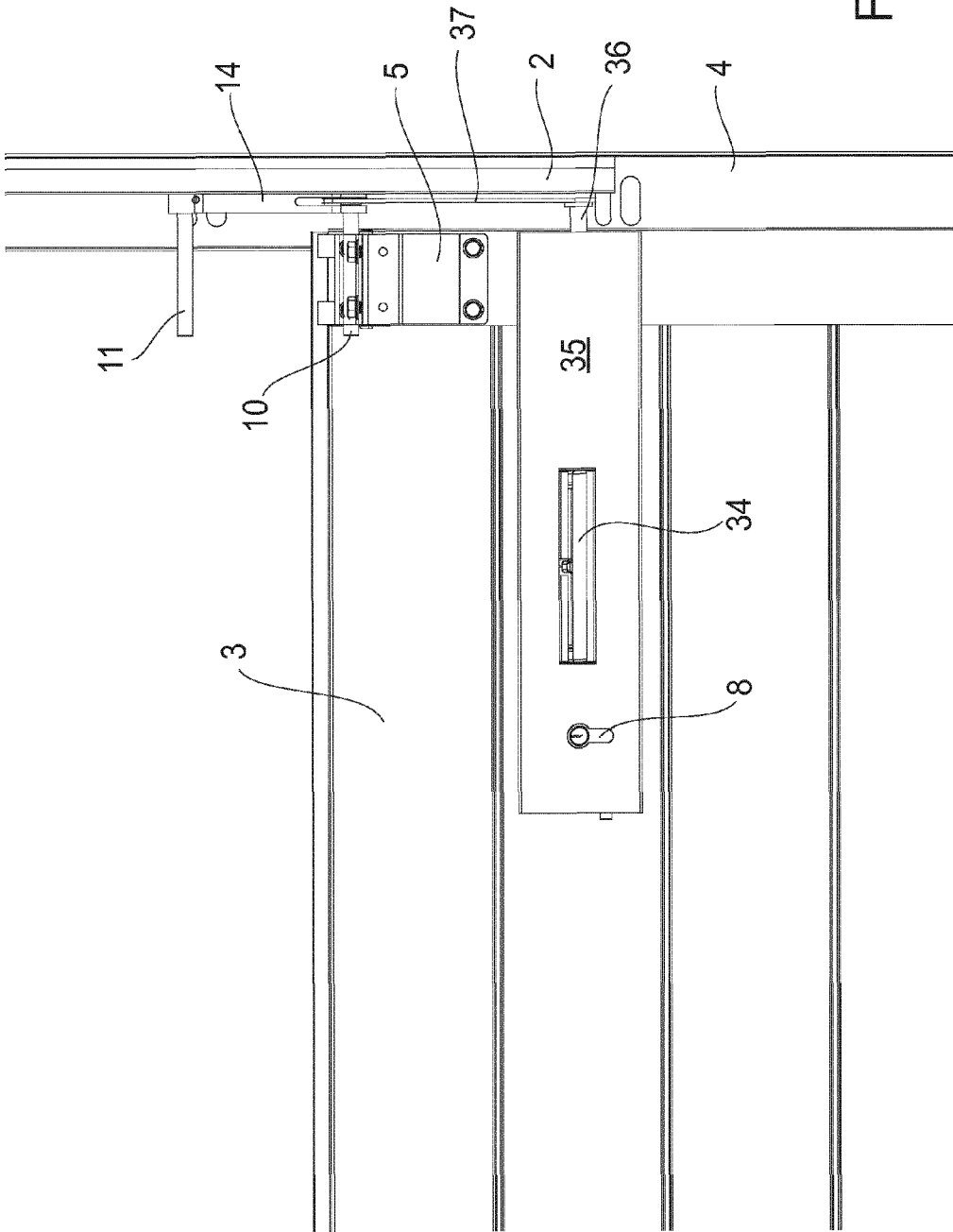

Fig. 12

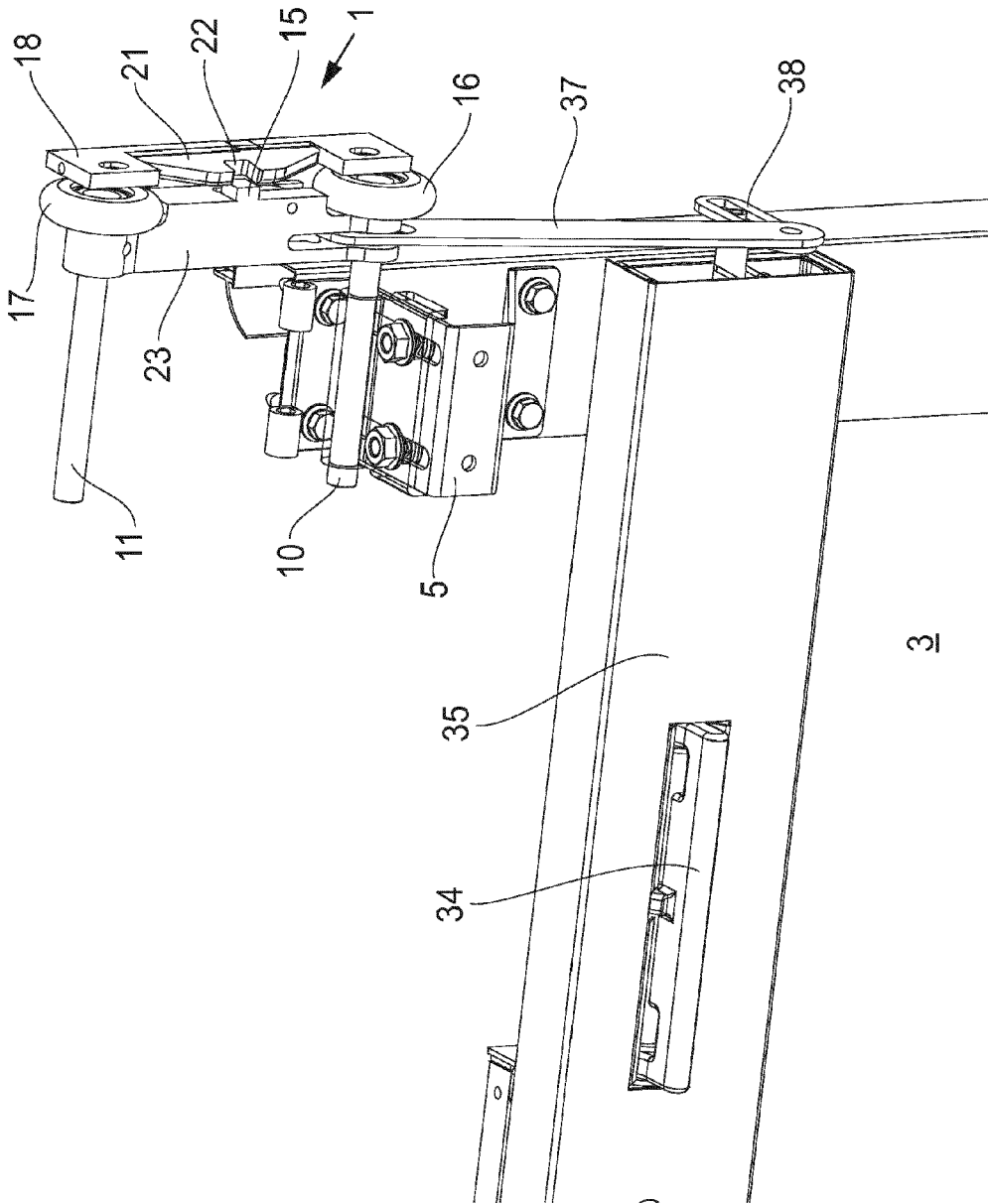

Fig. 13

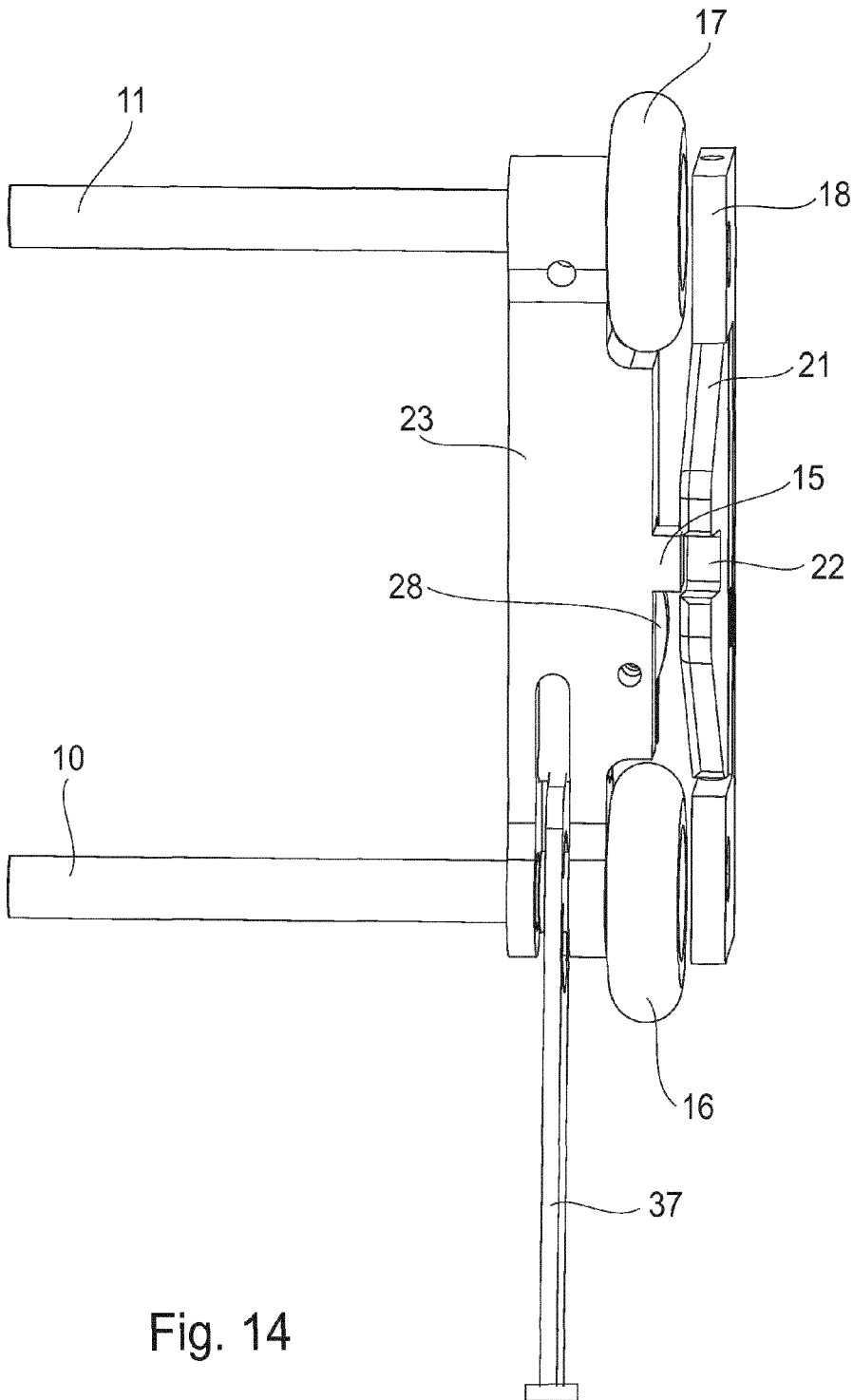

Fig. 14

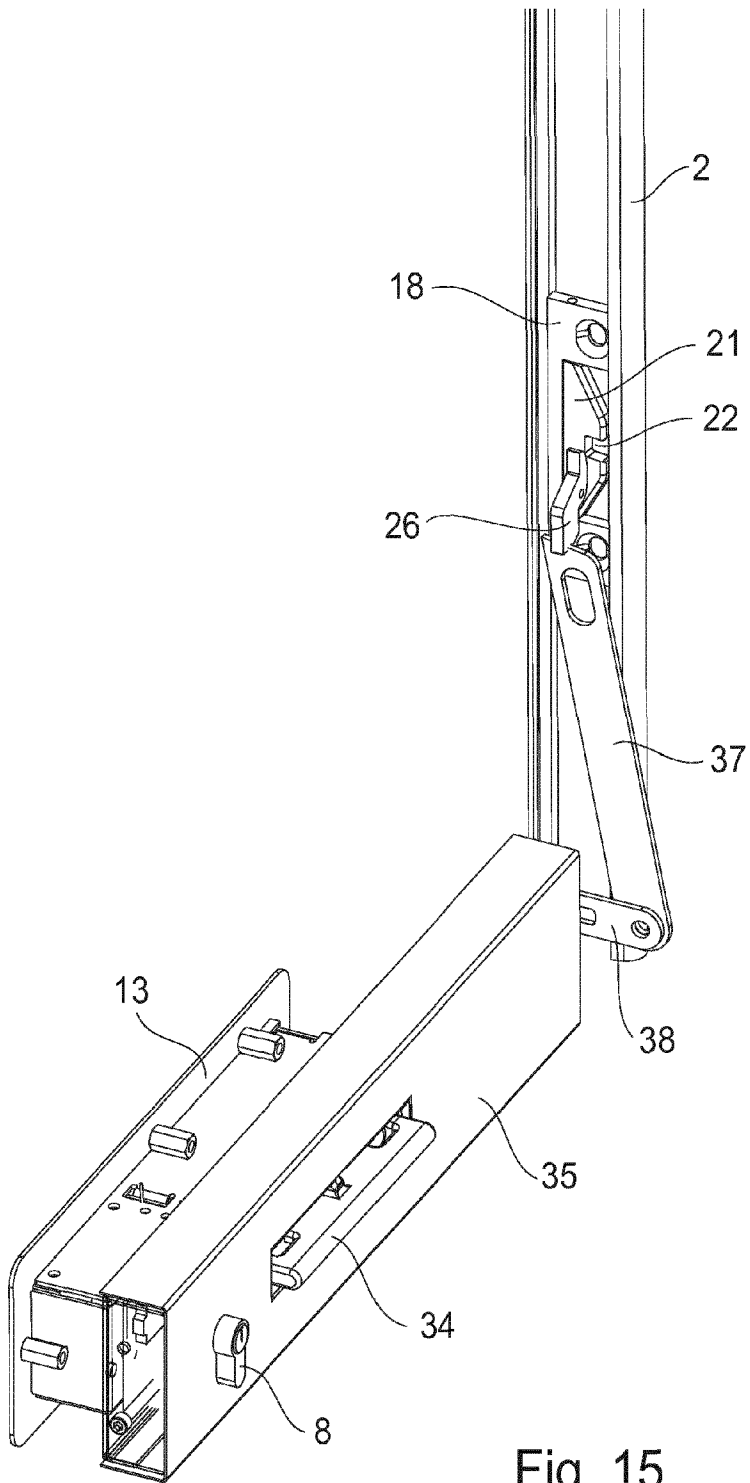

Fig. 15