

(No Model.)

2 Sheets—Sheet 1.

F. KEMPSMITH.  
UNIVERSAL HEAD FOR MILLING MACHINES.

No. 525,050.

Patented Aug. 28, 1894.

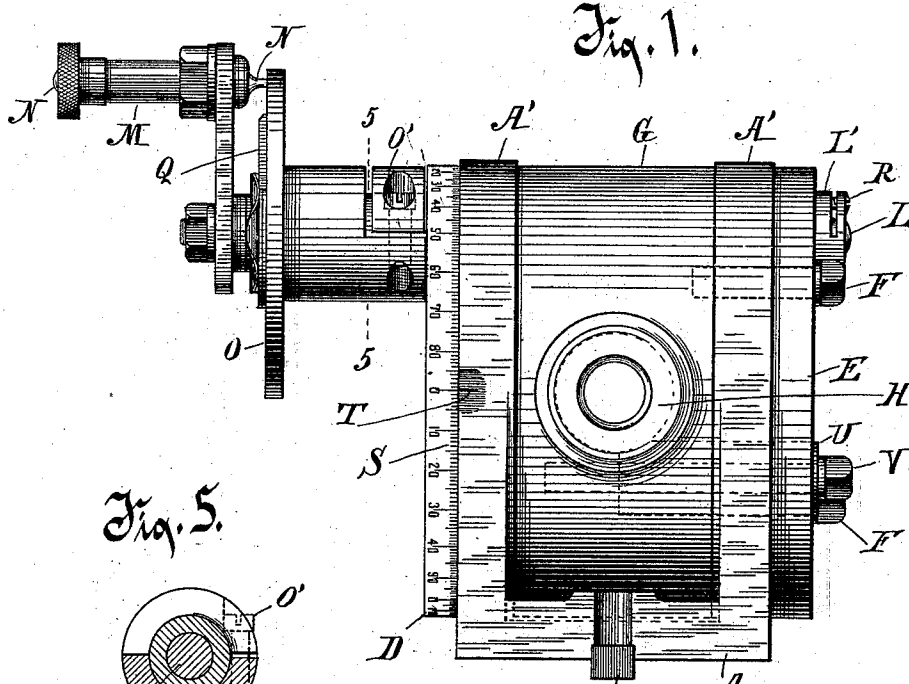

Fig. 5.

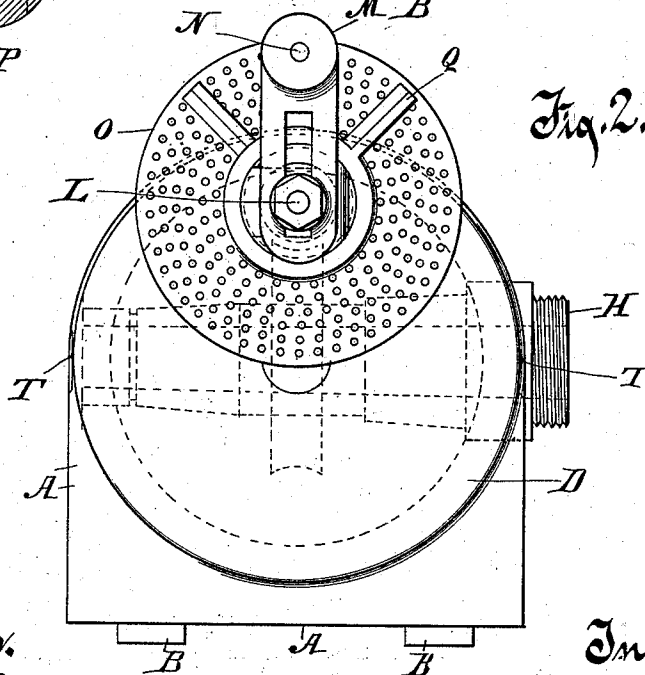
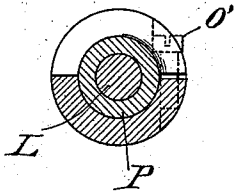

Fig. 2.

Witnesses.

*C. H. Keeney,*  
*Anna C. Faust.*

Inventor.

*Frank Kemp Smith*  
*By Benedict Morell*  
*Attorneys.*

(No Model.)

2, Sheets—Sheet 2

F. KEMPSMITH.  
UNIVERSAL HEAD FOR MILLING MACHINES.

No. 525,050.

Patented Aug. 28, 1894.

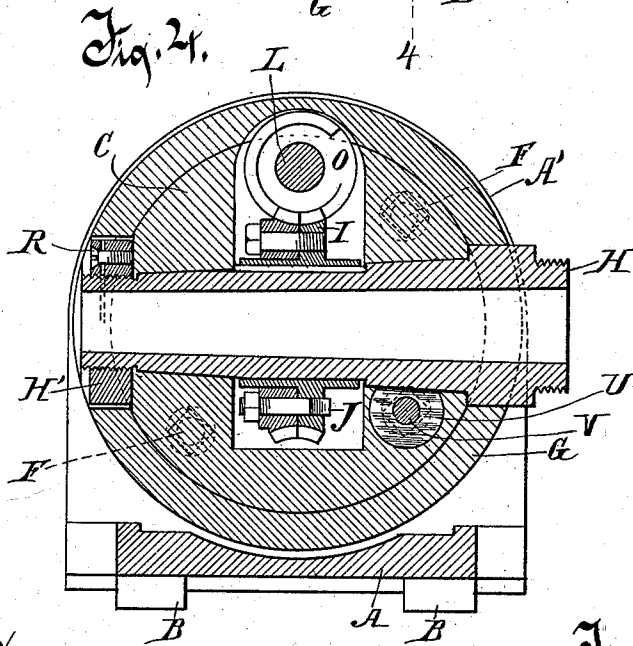
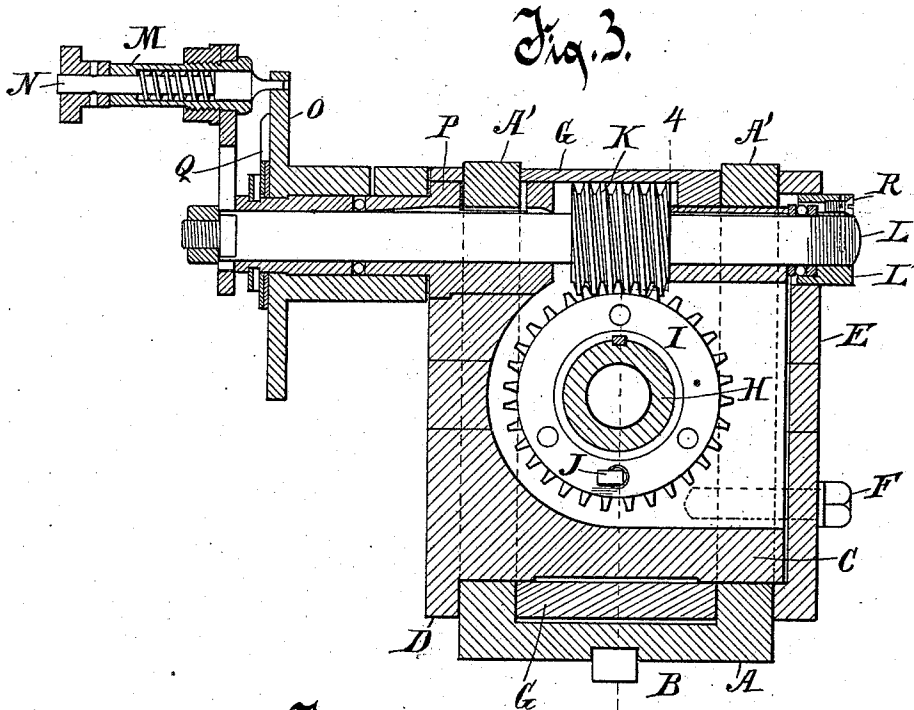

Witnesses.  
*A. H. Keeney*  
*Amos C. Faust*

Inventor.  
*Frank Kempsmith*  
*By Benedict Morell*  
Attorneys

# UNITED STATES PATENT OFFICE.

FRANK KEMPSMITH, OF MILWAUKEE, WISCONSIN.

## UNIVERSAL HEAD FOR MILLING-MACHINES.

SPECIFICATION forming part of Letters Patent No. 525,050, dated August 28, 1894.

Application filed April 27, 1894. Serial No. 509,178. (No model.)

### *To all whom it may concern:*

Be it known that I, FRANK KEMPSMITH, of Milwaukee, in the county of Milwaukee and State of Wisconsin, have invented a new and useful Improvement in Universal Heads for Milling-Machines, of which the following is a description, reference being had to the accompanying drawings, which are a part of this specification.

My invention relates to an improvement in universal heads used on milling machines.

The object of the invention is to provide a strong, reliable and easily manipulated device, capable of securely holding the article being operated on, at various angles, inclinations or positions, being readily adjusted to such positions or angles, by means therewith and forming a part thereof. The device is readily adapted for use with a gear-cutting machine, a drilling or boring machine, planing or milling machine, and by reason of its adaptation for all these and other purposes, and by reason of the extent of the movements of the parts of the device, I call it a universal head for milling machines.

The invention consists of the mechanism and its several parts herein described and claimed, or their equivalents.

In the drawings, Figure 1, is a side elevation of the complete device. Fig. 2, is a front elevation in outline. Fig. 3, is a central longitudinal section of the device. Fig. 4, is a transverse section on line 4—4 of Fig. 3. Fig. 5, is a transverse section on line 5—5 of Fig. 1.

In the drawings A is the frame, preferably constructed of cast iron, having a base adapted to rest movably on a suitable bed, and upwardly projecting side plates A' A' opposite each other at a little distance apart. Small blocks B B fixed in the base of the frame are adapted to enter a groove in the bed piece and help to hold the frame in place, and guide it when adjusted laterally on the bed. The frame is secured to the bed piece by bolts or other suitable devices. A substantially solid cylindrical block C having a somewhat enlarged cylindrical head D is fitted in and extends through the plates A'. The head D of the block bears against the outer surface of one of the plates A', and the other extremity of the block C projects slightly be-

yond the outer surface of the other plate A', and a cap E placed over the end of the block C bears at its inner circular edge against the plate. The cap E is secured in place by screws F F passing loosely through the cap and turning by their threads into the block C. An annular band G fitted between the plates A' encircles the block C, and is secured rigidly thereto by the structure hereinafter described. It will be understood that by this construction, the plates A' being slightly yielding, that the block C can be gripped and thereby locked to the frame by turning the screws F F whereby the cap E and the head D are drawn toward each other gripping the plates A' against the band G. It will also be observed that this construction is especially strong and solid so that when the parts are thus gripped together, they will stand up under a very severe strain thereon.

A hollow tapering, or truncated-cone shaped stock H is inserted transversely of the cylindrical block C in which it is fitted revolvably movable, and is secured therein by the nut H' turning thereon against a bearing in the block C. This stock H is adapted to receive a spindle or chuck therein for carrying thereon the article to be operated on. A worm wheel I, keyed onto the stock H, meshes with a worm K fixed on the shaft L, by the revolution of which shaft the stock is rotated. The shaft L is provided with a crank handle M having a spring actuated pin N, which pin takes into adjusting apertures in a revolvable index plate, which preferably is in the form of the perforated disk O. The disk O is secured adjustably on the tubular box P by means of a screw O' turning through a partially free segmental portion of the sleeve of the disk, into a permanent part of the sleeve of the disk, whereby the sleeve of the disk is clamped tightly onto the annular box P. The annular box P is fitted longitudinally in the block C, and is secured movably therein by the nut L' turning thereon against a washer interposed between it and the end of the box P, the box being provided with a suitable opposing shoulder near its other extremity bearing against the head D. An adjustable spring-held quadrant Q is arranged to sweep over the face of the disk O, and being adjusted to place, to guide the operator

in adjusting the pin N in suitable apertures in the disk O. It will be understood that this construction is adapted for rotating the stock H, and thereby adjusting the article thereon revolubly therewith, to such extent as is desired. The device, controlled by the screw O', for adjusting the index plate O on the box P, provides a convenient means for adjusting the index plate revolubly on the sleeve box through distances less than or equal to the spaces between the apertures in the disk, so that any one of these apertures can be brought in front of the pin N, for its engagement with the disk, thereby obviating the necessity to adjust the spindle or chuck in the stock, with exactness, or to adjust other and more complicated parts of the mechanism.

The worm wheel I is split and secured together by bolts through apertures in one half somewhat larger than the bolts, and by a wedge bolt J, whereby the parts may be shifted slightly forward and back relatively revolubly, to correct wear on the teeth.

The nuts H' and L' are partially split laterally, the parts being drawn together, after the nuts are turned down to their places, by screws R, whereby the nuts are locked in place on the male threads.

The head D is provided with a numbered graduated index S peripherally, running from 0 to 90 in each quadrant thereof, the degrees of the index are indicated in groups of ten by figures running from 0 to 80. On opposite sides of the plate A' at points in a line diametrically through the cylinder C, registering marks ten are provided on the plate A' whereby the block C and its load can readily be adjusted to any angle, by the rotation of the block vertically. This can always be readily accomplished by the operator on releasing the nuts F F. A pluglock U inserted in a suitable aperture therefor through the cap E and in the plug C, bears against the stock H, and when held to its seat snugly by the screw V passing through it and turning into the block C, holds the stock H against

revolution in the block. It will be understood that the cylindrical block C, is rotatable unlimitedly in the plates A' when the cap E is released, and that with an article holding spindle or chuck inserted in the projecting stock H, the block may be rotated from a position in which the lower end of the stock is depressed considerably below the horizontal at one side over to a similarly depressed position on the other side, so that the stock may be adjusted to any angle through nearly of quite three-fourths of a circle. This, in connection with the rotatability of the stock H, adapts the head for wide use as a universal head.

What I claim as my invention, and desire to secure by Letters Patent, is—

1. The combination of a frame having oppositely disposed upwardly projecting plates, a cylindrical block fitted therethrough and revoluble therein, the block having a head at one end bearing against the outer surface of a plate of the frame, a cap over and secured adjustably to the other end of the block, said cap bearing at its edge against the outer surface of the other plate of the frame, and a band around and fixed to the cylindrical block between the plates of the frame and against which they grip on tightening the cap, substantially as described.

2. In a universal head for milling machines, a worm shaft, a sleeve box in which the worm shaft rotates, an index plate mounted adjustable revolubly by means of a thereto rigid sleeve on the sleeve box, a partially free part of the disk sleeve, and a screw adapted to draw the partially free part of the sleeve to the rigid part, whereby the disk sleeve is clamped adjustably to the sleeve box, substantially as described.

In testimony whereof I affix my signature in presence of two witnesses.

FRANK KEMPSMITH.

Witnesses:

ARTHUR L. MORSELL,  
ANNA V. FAUST.