

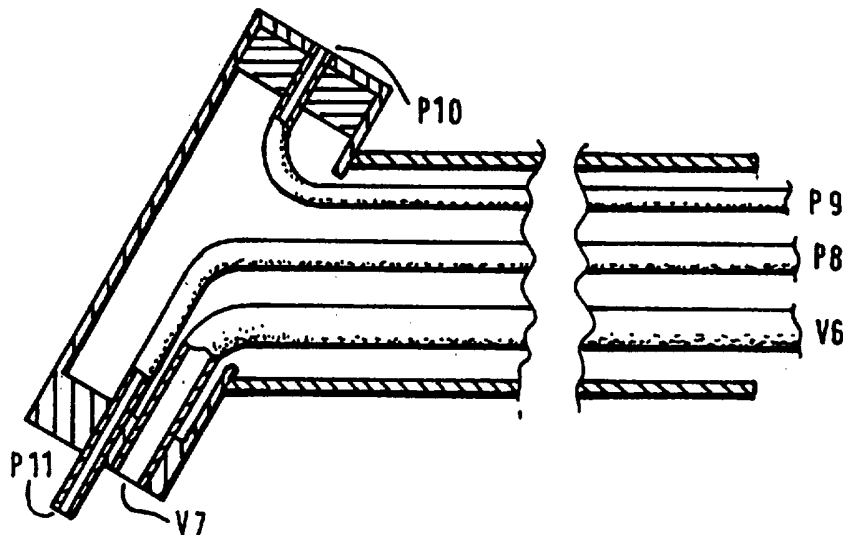

INTERNATIONAL APPLICATION PUBLISHED UNDER THE PATENT COOPERATION TREATY (PCT)

<p>(51) International Patent Classification ⁶ : A61B 17/54</p>	<p>A1</p>	<p>(11) International Publication Number: WO 97/11650 (43) International Publication Date: 3 April 1997 (03.04.97)</p>
<p>(21) International Application Number: PCT/GB96/02395 (22) International Filing Date: 25 September 1996 (25.09.96) (30) Priority Data: 9520209.9 25 September 1995 (25.09.95) GB (71)(72) Applicant and Inventor: CAWLEY, Richard, William [GB/GB]; t/a Sequis, St. John's Works, Bromley Road, Elmstead Market CO7 7DP (GB). (74) Agents: BARRETT-MAJOR, Julie, Diane et al.; Sanderson & Co., 34 East Stockwell Street, Colchester, Essex CO1 1ST (GB).</p>		<p>(81) Designated States: AL, AM, AT, AU, AZ, BA, BB, BG, BR, BY, CA, CH, CN, CU, CZ, DE, DK, EE, ES, FI, GB, GE, HU, IL, IS, JP, KE, KG, KP, KR, KZ, LC, LK, LR, LS, LT, LU, LV, MD, MG, MK, MN, MW, MX, NO, NZ, PL, PT, RO, RU, SD, SE, SG, SI, SK, TJ, TM, TR, TT, UA, UG, US, UZ, VN, ARIPO patent (KE, LS, MW, SD, SZ, UG), Eurasian patent (AM, AZ, BY, KG, KZ, MD, RU, TJ, TM), European patent (AT, BE, CH, DE, DK, ES, FI, FR, GB, GR, IE, IT, LU, MC, NL, PT, SE), OAPI patent (BF, BJ, CF, CG, CI, CM, GA, GN, ML, MR, NE, SN, TD, TG).</p> <p>Published <i>With international search report. Before the expiration of the time limit for amending the claims and to be republished in the event of the receipt of amendments.</i></p>

(54) Title: APPARATUS AND METHOD FOR MICRODERMOABRASION



(57) Abstract

Improvements in apparatus for use in microdermoabrasion in which unused microcrystals are delivered from a handset to skin and used microcrystals are drawn back into the handset together with skin debris, which apparatus comprises: (a) a first container for unused microcrystals, (b) a second container for used microcrystals, (c) a handset provided with a delivery aperture for delivering unused microcrystals to skin and for receiving used microcrystals and skin debris, (d) first means for providing an airstream to the handset delivery aperture via an air pressure outlet, (e) second means adapted to withdraw used crystals from the skin via a vacuum inlet, are described including the provision of trigger means to enable unused microcrystals to be delivered from the delivery aperture when triggered but otherwise to prevent or reduce delivery of unused microcrystals even during operation of the first and/or second means.

FOR THE PURPOSES OF INFORMATION ONLY

Codes used to identify States party to the PCT on the front pages of pamphlets publishing international applications under the PCT.

AM	Armenia	GB	United Kingdom	MW	Malawi
AT	Austria	GE	Georgia	MX	Mexico
AU	Australia	GN	Guinea	NE	Niger
BB	Barbados	GR	Greece	NL	Netherlands
BE	Belgium	HU	Hungary	NO	Norway
BF	Burkina Faso	IE	Ireland	NZ	New Zealand
BG	Bulgaria	IT	Italy	PL	Poland
BJ	Benin	JP	Japan	PT	Portugal
BR	Brazil	KE	Kenya	RO	Romania
BY	Belarus	KG	Kyrgystan	RU	Russian Federation
CA	Canada	KP	Democratic People's Republic of Korea	SD	Sudan
CF	Central African Republic	KR	Republic of Korea	SE	Sweden
CG	Congo	KZ	Kazakhstan	SG	Singapore
CH	Switzerland	LI	Liechtenstein	SI	Slovenia
CI	Côte d'Ivoire	LK	Sri Lanka	SK	Slovakia
CM	Cameroon	LR	Liberia	SN	Senegal
CN	China	LT	Lithuania	SZ	Swaziland
CS	Czechoslovakia	LU	Luxembourg	TD	Chad
CZ	Czech Republic	LV	Latvia	TG	Togo
DE	Germany	MC	Monaco	TJ	Tajikistan
DK	Denmark	MD	Republic of Moldova	TT	Trinidad and Tobago
EE	Estonia	MG	Madagascar	UA	Ukraine
ES	Spain	ML	Mali	UG	Uganda
FI	Finland	MN	Mongolia	US	United States of America
FR	France	MR	Mauritania	UZ	Uzbekistan
GA	Gabon			VN	Viet Nam

APPARATUS AND METHOD FOR MICRODERMOABRASION

The present invention relates to improvements in apparatus for carrying out microdermoabrasion, in particular improvements in the handset thereof, its construction and use in the treatment of skin.

5 Classically, skin abrasion has been carried out by mechanical or chemical means. However, it was long-recognised in the fields of plastic surgery and dermatology that a more controllable method of skin abrasion had to be found. Without such control, the
10 abrasion could be too strong resulting in blood being drawn.

 Therefore, a system was developed which may be termed controlled microdermoabrasion which is effected by "firing" through the skin inert microcrystals via a
15 handset fitted with a disposable plastic nozzle. The layers of skin are thereby able to be abraded as required, according to the depth of the blemish/scar to be erased.

 The advantages of this method compared to
20 classical dermoabrasion include the absence of biological harm to the tissues being abraded and the capability for the operator to be able to select the required abrasion depth. The treatment does not require a local anaesthetic; can be carried out on out-
25 patients and can be repeated as and when required. There is now a trend for such treatments to be carried out in beauty salons.

 Microdermoabrasion is therefore based on the following modus operandi:
30 via a fine point or aperture, connected to the main body of the apparatus, the part of skin to be treated is aspirated and, at the same time, a controlled jet of

microcrystals flowing through a channel results in exfoliation of the skin. The microcrystals can then be immediately aspirated via the same fine point or aperture, through a different channel, together with skin impurities and cell debris. Dependent upon both the length of time of application of the point or aperture to each skin section and the intensity of the abrasion, the treatment will result in varying degrees of penetration. Therefore, treatment may be limited to the stratum corneum (resulting in light peeling) or may act at a deeper level in accordance with the particular pathology.

Microdermoabrasion may be used in connection with the following indications, not only in aesthetics: acne scars; burns; cheloids; chickenpox scars; dark and pigmentation marks; facial peels; hypertrophic scars; small facial scars; reduction of post traumatic scarring; reduction of wrinkles; stretch marks or atrophied striae; surface capillaries; and tattoo removal, but also in trichology, for the treatment of symptoms associated with excess sebaceous secretion, scurf and hair fall; and also in preparation for surgery.

Presently-available apparatus can provide aspiration by suction/vacuum alone or by a combination of air pressure/compression with suction/vacuum in which latter case the crystal jet is accelerated, resulting in a quicker and deeper abrasion. The latter is generally used when treating scar tissue and acne scars, i.e., more resistant inaesthetisms. Both suction and pressure can be adjusted to suit.

The crystals used may be of aluminium or aluminium oxide (Al_2O_3) or corundum. Hence, preferred systems work by projecting from a handset a high-pressure stream of Al_2O_3 microcrystals against the skin. The Al_2O_3 microcrystals used are chemically inert. They

are able to provide a gentle, uniform abrasion of the tissues being treated. As soon as contact is made between the aperture of the handset and the skin, a vacuum is formed triggering the release of the crystals and beginning the dermoabrasion process. The handset is usually designed to enable the practitioner to sweep the skin surface and/or treat specific areas of approximately 1-2 mm in diameter. At the same time, the use of an electropneumatic vacuum induces a hyperemia effect on the skin, which encourages skin tissue regeneration as well as making it possible to suck off the used or excess crystals.

Typical, known, apparatus therefore comprises a first container for unused crystals, a second container for used crystals, a conduit connecting the containers via a handset provided with a delivery aperture for delivering crystals to skin, first means associated with the first container for providing an airstream adapted to transport unused crystals to the handset aperture, second means associated with the second container adapted to withdraw used crystals from the skin and to deliver the used crystals to the second container.

Usually, the first means comprises an air compressor and the second means comprises a suction pump. However, some apparatus may rely solely on the use of a vacuum pump both to deliver unused crystals to the skin and to withdraw used crystals from the skin. The skin thereby acts as part of the crystal flow conduit between the first and second containers once the delivery aperture, usually positioned in a replaceable or disposable nozzle on the handset for hygiene reasons, contacts the skin thereby forming a vacuum.

Therefore, prior art apparatus using both vacuum and air pressure have a suction/vacuum inlet positioned

in line as part of the crystal flow conduit and have the suction/vacuum inlet positioned forward of the air pressure outlet in the handset delivery aperture. Furthermore, prior art apparatus has the delivery aperture positioned to the side of the handset and the disposable nozzle is therefore adapted to fit the handset in one position only to allow the crystals to be ejected through the delivery aperture via a matching treatment aperture in the nozzle. Although some apparatus are provided with an optional foot pedal which is adapted to enable a higher pressure or more intensive effect when in use, generally, existing designs do not allow for significant flexibility of use. Therefore, skin treatments which can be administered are limited or at least difficult to vary in a controlled manner whilst in use. Furthermore, as soon as the treatment aperture is removed from the skin, crystals tend to scatter from the aperture until the apparatus is completely switched off, or the vacuum pump and/or air compressor are switched off or the high pressure foot pedal released.

The present invention provides an improvement in the known apparatus by locating the air pressure outlet forward of the suction (vacuum) inlet in the handset. This allows for the use of interchangeable nozzles, which are also provided and which can change the working relationship between the newly-positioned pressure outlet and suction inlet. Examples of these nozzles are further described below. The delivery aperture is preferably to the front end, rather than to the side, of the handset.

A further improvement comprises trigger means, preferably sited on the handset, for activating crystal flow when triggered but which otherwise prevents or reduces crystal flow, even when the vacuum pump and/or compressor is still in operation. Therefore, the

present invention provides apparatus for use in microdermoabrasion in which unused microcrystals are delivered from a handset to skin and used microcrystals are drawn back into the handset together with skin debris, which apparatus comprises

- 5 (a) a first container for unused microcrystals
- (b) a second container for used microcrystals
- (c) a handset provided with a delivery aperture for delivering unused microcrystals to skin and for
10 receiving used microcrystals and skin debris
- (d) first means for providing an airstream to the handset delivery aperture via an air pressure outlet
- (e) second means adapted to withdraw used crystals
15 from the skin via a vacuum inlet

wherein trigger means is provided to enable unused microcrystals to be delivered from the delivery aperture when triggered but otherwise prevents or reduces delivery of unused microcrystals even during operation of the first and/or second means.

20 Preferably, the trigger means is an aperture located on the handset in a position convenient to be covered with an operator's finger when in use. Advantages of the handset of the present invention over prior art systems therefore include activation of
25 crystal flow by touching the trigger aperture. This low force action enables the operator to keep both feet steady on the ground and a steady hand on the handpiece; it also allows the operator to move around the patient; conventional hand and foot-operated
30 controls do not achieve these.

More preferably, the trigger means comprises a trigger aperture in the handset associated with means for providing the airstream to the handset and/or means for providing unused microcrystals to the handset.

35 For example, the trigger aperture may be connected to a low air pressure conduit associated with a

5 signalling system to detect air pressure in the conduit and to transmit a signal, at a predetermined pressure, adapted to switch the airstream (provided by the first means or air compressor) to the first container; and at a lower pressure than the predetermined air pressure to switch the airstream to vent the airstream, and optionally also to disconnect the airstream from the first container.

10 The signalling system preferably comprises an air switch which co-operates with a solenoid valve to activate or deactivate airflow upstream of the first container of unused crystals. In use, when the operator's finger covers the trigger aperture, the change in pressure is detected by the air pressure
15 switch which switches the air stream from the pump through to the first container of crystals; and vice versa.

A mode selector may also be provided which operates a crystal/bypass select system which
20 exclusively or partially directs the airstream through the first container and/or bypasses the first container. In the case where a crystal/bypass select system is used, the efficiency of the abrasion is improved and the apparatus is more economic with
25 respect to crystal use. The bypass system allows for more air to be mixed with the crystals, resulting in a thinner mixture than easily obtainable in the prior art systems.

30 Alternatively, the trigger aperture, when closed, operates both a valve enabling the airstream to be provided to the handset and a valve enabling unused microcrystals to be released into the airstream. The advantages of such an arrangement include the possibility of locating the first container (of unused
35 microcrystals) on or in the handset. At least two significant improvements accrue therefrom: the

microcrystals do not mix with the airstream until just prior to the point of delivery from the delivery aperture. This prevents blockages occurring at the point (the restrictor) where the airstream line is usually constricted to provide a high pressure jet of air (or air/crystal mixture) to the delivery aperture; also, the bore of the restrictor can be smaller and airstream velocity higher. Furthermore, this possibility means that sealed, replaceable containers may be used to supply the microcrystals, even on a 1-per treatment basis, so that handling is minimised, and bulk volumes are not exposed to dampness and other environmental contaminants. These containers may be disposable, rigid cartridges or soft, bag-like 'refills'. This arrangement means that the airstream is directly controlled at the point of use by the trigger/valve system; and the supply of microcrystals can likewise be controlled. The crystals may be fed into the airstream jet by pressure, gravity or syphon action.

More preferably, the apparatus of the present invention is provided with a sensor which detects the change in the vacuum level once the delivery or treatment aperture is removed from contact with the skin and is provided with means for switching off the airstream, hence simultaneously preventing crystal flow. The advantage of including this sensor is to prevent the possibility of accidentally firing crystals when the treatment aperture is not in contact with the skin to be treated.

The apparatus may also provide means for activating the vacuum as soon as the handset is removed from a holding position thereon but, because of the trigger and/or vacuum sensor systems, no crystals flow until the handset is in contact with the skin to be treated and the trigger aperture is covered.

The apparatus may also be provided with means for switching the vacuum supply through the first container, thereby preventing crystal flow. This enables the vacuum to be used (in the absence of
5 crystal flow) to clean the skin or handset by extracting used or retained crystals.

The apparatus of the present invention may be used with various fluid and transported media to etch, polish, abrade, clean or colour.

10 The apparatus of the present invention can also be adapted for use with other cosmetic or medical equipment such as massage heads.

The apparatus may further comprise one or more of the following additional features:

- 15 1. Detachable mains lead.
2. Crystal supply or first container adapted to be installed through sealable access in apparatus casing or handset.
3. Used crystals or second container adapted to be
20 emptied through sealable access in apparatus casing.
4. Used crystals and/or supply of unused crystals adapted to be visible through windows in side of casing and/or by L.E.D. indicators such as a bargraph on a front panel.
- 25 5. Air and/or vacuum levels limited internally to predetermined safe levels.
6. Air and/or vacuum levels adapted to be adjustable by controls on front panel of apparatus optionally with L.E.D. bargraph metering or by analogue gauge or other
30 meter.
7. Handset preferably with integral trigger for crystal flow in 'pen' style.

The apparatus is preferably operated as follows:

35 Main power switch on front panel of apparatus is operated. L.E.D. displays become active. Pumps energise; no external air supply is enabled, and

optionally also no vacuum supply is enabled. The operator selects mode of operation by means of front panel control, including vacuum-only; vacuum plus air which can be used to clean skin of any residue from crystals, and with dummy nozzle or cover fitted will clean tubes and protect from contamination; and vacuum plus crystals. Alternatively, the operator may choose between pre-set air/vacuum levels. Lifting handpiece from holder or bracket on apparatus may switch vacuum supply to nozzle. Contacting nozzle with skin enables operation of air trigger on handpiece. When trigger is touched in vacuum plus crystals mode, the air flow commences to the first container and crystals flow; in vacuum plus air mode, the airstream flows. Alternatively, it may operate the valve for airflow simultaneously with the valve for crystal flow. Once in operation, the vacuum and air levels can optionally be monitored and adjusted by means of external controls and gauges.

The present invention will now be described by way of example only with reference to the accompanying drawings in which:

Figure 1 is a schematic diagram of apparatus according to the present invention wherein the first container is in the apparatus casing;

Figure 2 is an enlarged lateral cross-section through the handset of Figure 1; and

Figures 3B and 4B are vertical sections of examples of interchangeable nozzles fitted to a handset according to the present invention, corresponding figures 3A and 3B are cross-sections thereof.

Figure 5 is a schematic diagram of apparatus according to the present invention wherein the first container is associated with the handset.

Figure 6 is an enlarged lateral cross-section through the handset of Figure 5.

Referring to Figure 1, in use, a power switch (not shown) activates an air pump (P1) and a vacuum pump (V1). Displays (M3 and M4) for crystal levels detected by reservoir and filter level sensors (O51 and O52) in unused and used crystal containers, respectively, illuminate.

Removing the handset (H) from a holder on the main unit (not shown) operates a solenoid inhibit switch (SW2). A vacuum solenoid valve (V2) turns the vacuum supply on at a handset vacuum port (V7). A vacuum bargraph (M2) now displays the minimum selected vacuum level. Contacting the handset nozzle (N1) to skin operates an air solenoid interlock (A1). The maximum selected vacuum level now shows on the bargraph (M2).

Closing a trigger port (P10) distal from the nozzle (N1) on the handset (H) by covering it with a finger operates, via a conduit (P9), an air switch (P2). An air solenoid valve (P3) turns air supply on to a handset air port (P11) which is sited downstream of the handset vacuum port (V7) and restricts the air passage to create a high velocity jet. An air bargraph (M1) now displays air pressure level. Air pressure is metered (P4) and controlled (P5) downstream of the air solenoid valve (P3) and air switch system (P2) but upstream of the first container of unused crystals (P7). A conduit (P8) carries the resulting air/crystal mixture to the restrictor port (P11). The air and vacuum bargraphs (M1 and M2) are generated from respective transducers (T1 and T2) whose output is amplified (A1 and A2).

The function of the airstream is determined by the position of a crystal/by-pass select (P6), which enables/disables crystal flow to the handset air port (P11). This has the effect of allowing more or less air to be mixed with the crystals and to be delivered to the handset (H).

The airstream can be switched on and off by operation of the trigger port (P10). Breaking contact between the skin and nozzle (N1) will turn off the air stream.

5 Vacuum is metered (V3) and controlled (V4) downstream of the vacuum solenoid valve (V2) and upstream of the filter (V5) for used crystals and skin debris. Vacuum is supplied to the handset vacuum port (V7) via a conduit (V6). When the filter level display
10 (M4) indicates filter (V5) is full, the filter must be emptied before further use.

The advantages of having the air pressure line forward of the vacuum line include the possibility of using interchangeable nozzles which are adapted for use
15 for different types of treatment. For example, as shown in Figure 3, treatment can be provided by a funnel-shaped nozzle having an aperture which, when fitted, is concentric with the air pressure outlet (P11) of the delivery aperture. Because the vacuum
20 inlet (V7) is also concentric thereto (as it is contained within the funnel), an intense effect is given to crystal flow. The smaller the nozzle treatment aperture, the more intense the treatment. On the other hand, as shown in Figure 4, for abrading
25 larger surface areas, a funnel-shaped baffle can be fitted to the air pressure outlet (P11) with a cylindrical nozzle fitted thereover. Thereby, the crystal flow is forced forwards and outwards, enabling an arc of up to 10mm diameter of skin to be abraded.
30 For cleaning the skin or to cool it after abrading treatment, air flow can be activated to a cylindrical nozzle where the treatment aperture comprises the area of the cylinder-end in the absence of crystals (selecting air only), which results in gentler cleaning
35 than by vacuum-only. For cleaning the handset and crystal flow conduits, a similar nozzle but having a

cylinder end-cap or cover can be used.

Therefore, the nature of the flow from high pressure (air outlet (P11)) to low pressure (vacuum inlet (V7)) may be determined by the design of removable nozzles which can be fitted to the air pressure outlet (P11), to the body of the handset and/or to the vacuum inlet (V7) to allow different tasks to be performed.

Referring to the embodiment of Figures 5 and 6 in which the container of unused crystals (P15) is removably mounted via a screw-thread on a handset (shown by broken lines) having an aluminium alloy body: once the apparatus is switched on, air from a compressor (P11) is supplied to regulators (P13), each of which is pre-set to a different pressure corresponding to the required intensities of abrasion. The apparatus initially vents the air to atmosphere through a valve (P12); this prevents airflow through the system downstream to the handset to a handset air port (P111). Simultaneously, vacuum flows from a vacuum pump (V11) through a vacuum control/vent (V12) and via a filter system (V14 & V15) to the handset nozzle or outlet (H), the components of which are made of stainless steel.

When a mode is selected on the control panel of the apparatus (DC), the air pressure control (P13) is switched to the pre-selected pressure, and the vacuum control (V12) is switched to the pre-selected vacuum by switching in or out a flow restrictor (also in V12) which vents to atmosphere. The vacuum to the handset is thus pre-selected.

Contacting the handset nozzle on the skin causes an increase in vacuum level in the system, which is monitored (V13) and generates a signal downstream of the vacuum/vent (V12) but upstream of a filter (V5) which is operated via a filter clean solenoid valve

(V4). On receiving the signal, the air pressure vent (P12) closes and pressure is supplied via a hose (shown as solid line) to an air valve (P14) mounted inside the handset. Manual operation (by a button (P16) itself operated by a lever (P17)) of the air valve (P14) causes a high velocity airstream to eject via a restrictor (R) through the handset air port (P111) in the nozzle (H). Operation of the same lever (P17) causes lifting of a valve (P18) in a duct connecting the container (P15) to the airstream, thereby allowing crystals to flow from the unused crystals container (P15) and mix with the airstream so produced. A vent (P19) in the crystal reservoir (P15) allows air to replace in the container (P15) the volume of delivered crystals. Skin debris and used crystals are returned to the apparatus via the handset vacuum port (V17).

CLAIMS

1. Apparatus for use in microdermoabrasion in which unused microcrystals are delivered from a handset to skin and used microcrystals are drawn back into the handset together with skin debris, which apparatus
5 comprises
- (a) a first container for unused microcrystals
 - (b) a second container for used microcrystals
 - (c) a handset provided with a delivery aperture for delivering unused microcrystals to skin and for
10 receiving used microcrystals and skin debris
 - (d) first means for providing an airstream to the handset delivery aperture via an air pressure outlet
 - (e) second means adapted to withdraw used crystals from the skin via a vacuum inlet
- 15 wherein trigger means is provided to enable unused microcrystals to be delivered from the delivery aperture when triggered but otherwise prevents or reduces delivery of unused microcrystals even during operation of the first and/or second means.
- 20 2. Apparatus as claimed in claim 1 wherein the trigger means comprises an aperture in the handset associated with means for providing the airstream to the handset.
3. Apparatus as claimed in claim 1 or claim 2
25 wherein the trigger means comprises an aperture in the handset associated with means for providing unused microcrystals to the handset.
4. Apparatus as claimed in claim 2 or claim 3 wherein the trigger aperture, when closed, operates
30 both a valve enabling the airstream to be provided to the handset and a valve enabling unused microcrystals to be released into the airstream.
5. Apparatus as claimed in any of claims 1 to 4 wherein the first container for unused microcrystals is
35 located in or on the handset.

6. Apparatus as claimed in claim 2 or claim 3 wherein the trigger aperture is connected to a low air pressure conduit associated with a signalling system to detect air pressure in the conduit and to transmit a signal, at a predetermined pressure, adapted to switch the airstream to the first container; and at a lower pressure than the predetermined air pressure to switch the airstream to vent the airstream.

7. Apparatus as claimed in claim 6 wherein the signalling system comprises an air switch which cooperates with a solenoid valve to activate or deactivate airflow upstream of the first container of unused crystals.

8. Apparatus as claimed in any preceding claim provided with a sensor which detects changes in vacuum level whereby, when the delivery aperture is not in contact with skin, delivery of unused microcrystals from the delivery aperture is prevented.

9. Apparatus as claimed in any preceding claim wherein the air pressure outlet is located in the handset downstream of the vacuum inlet.

10. A method of microdermoabrasion which method comprises delivering unused microcrystals from a handset to skin which handset is associated with apparatus according to any of claims 1 to 9.

1/4

FIG. 1A

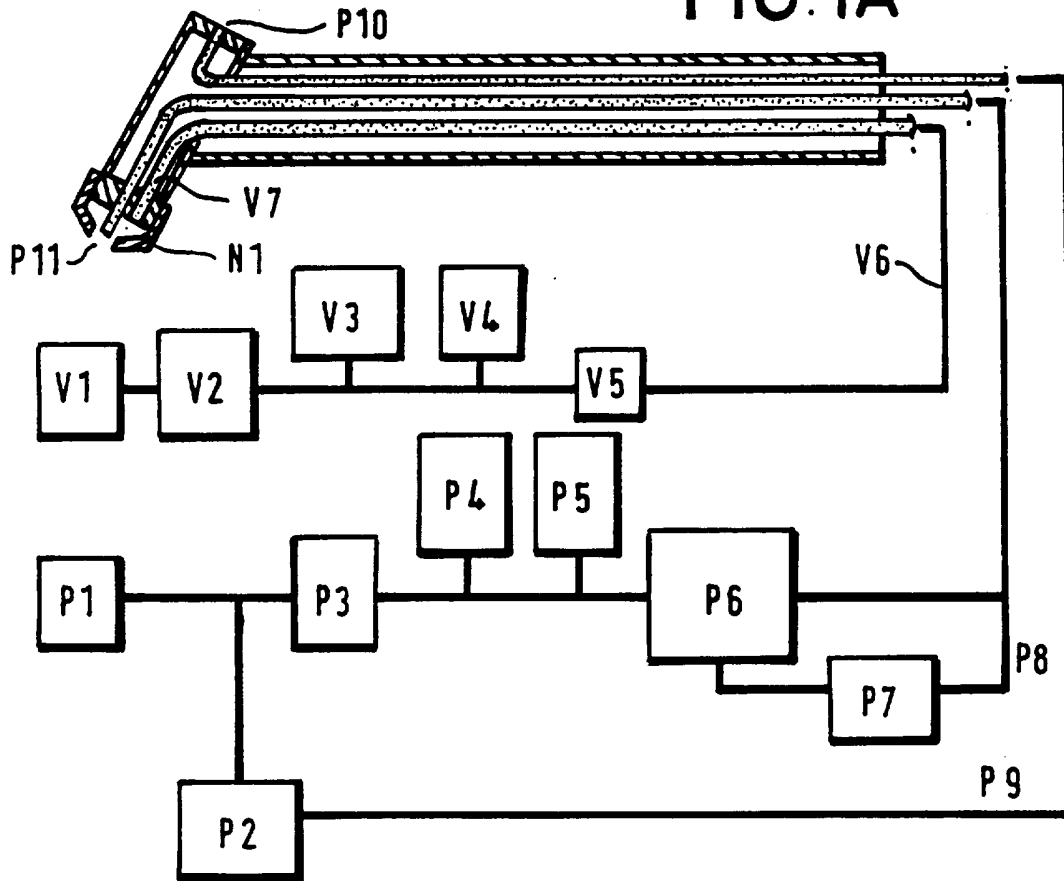
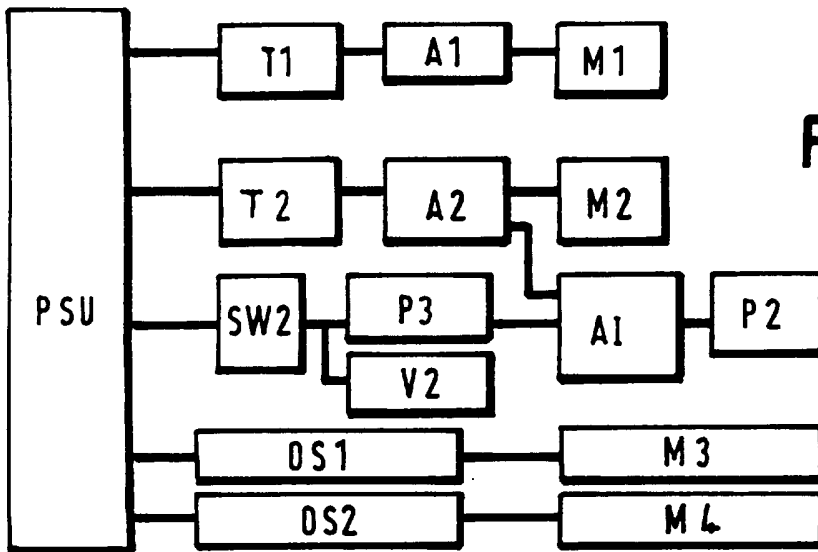

FIG. 1B



2/4

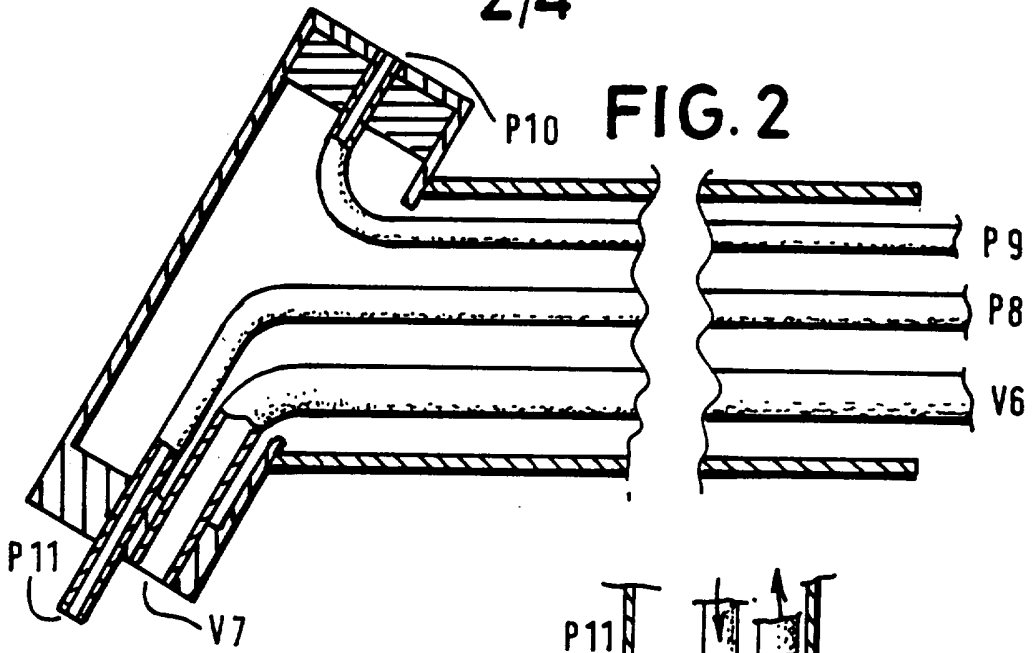

FIG. 2

FIG. 3A

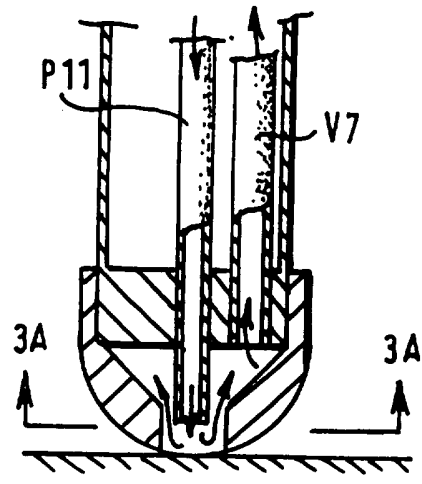
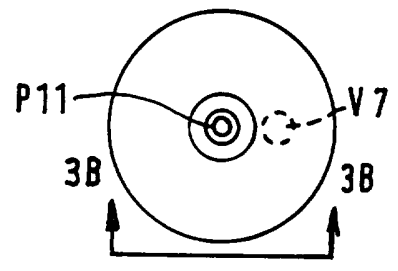

FIG. 3B

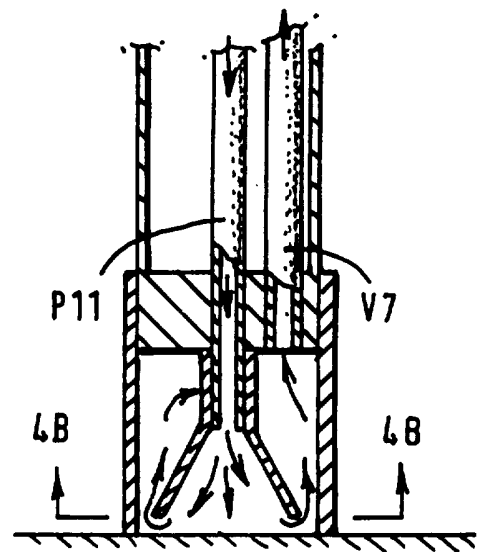

FIG. 4A

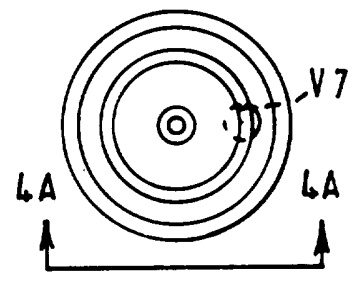
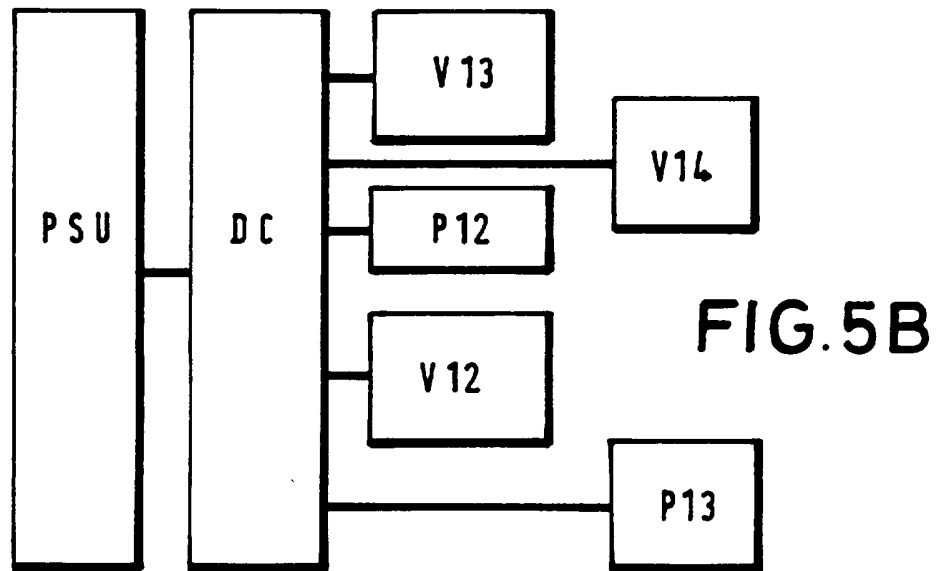
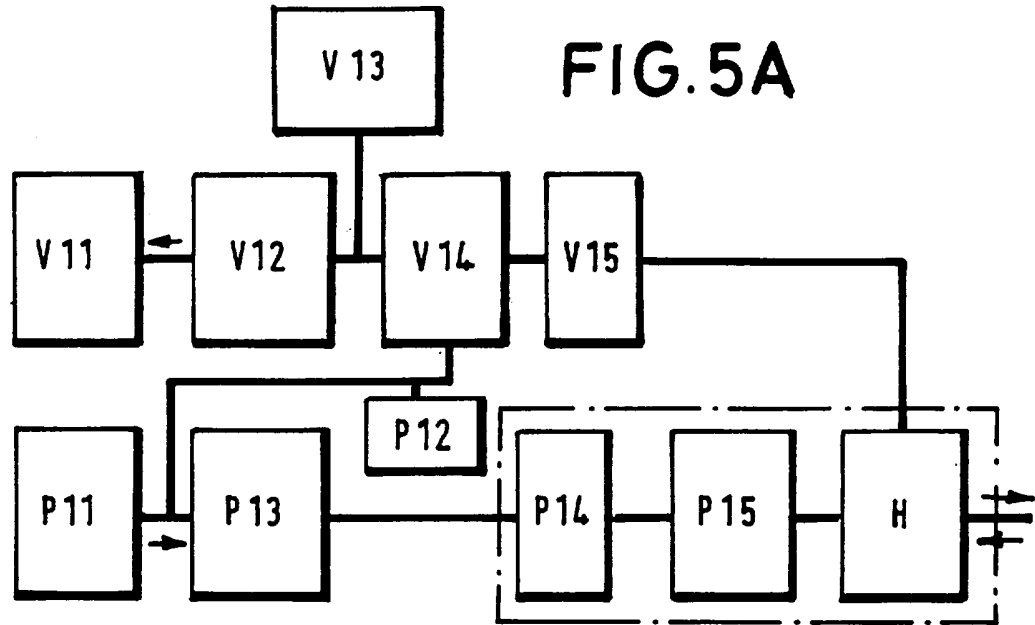
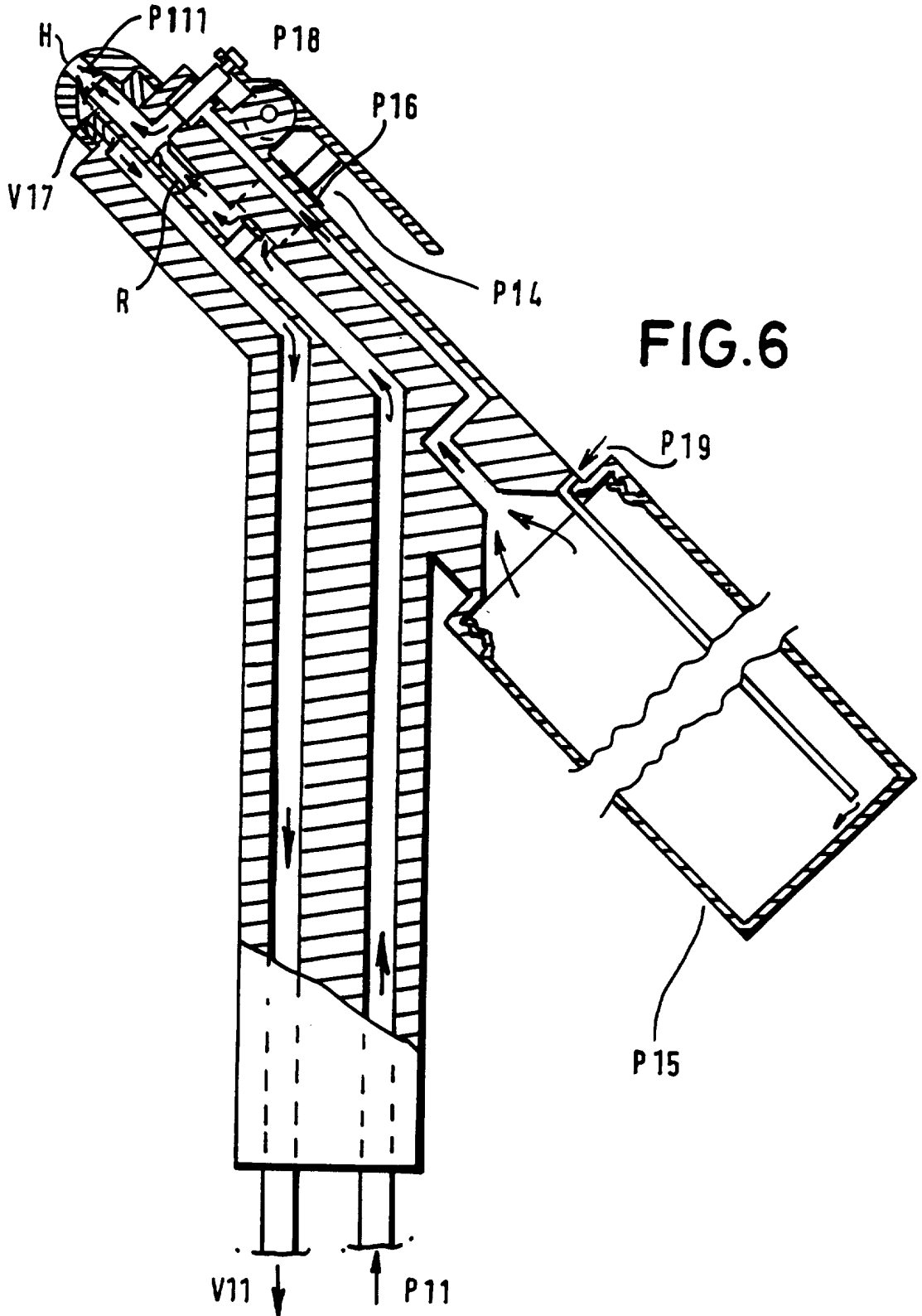

FIG. 4B

3/4



4/4



INTERNATIONAL SEARCH REPORT

International Application No
PCT/GB 96/02395

A. CLASSIFICATION OF SUBJECT MATTER
IPC 6 A61B17/54

According to International Patent Classification (IPC) or to both national classification and IPC

B. FIELDS SEARCHED

Minimum documentation searched (classification system followed by classification symbols)
IPC 6 A61B A61C

Documentation searched other than minimum documentation to the extent that such documents are included in the fields searched

Electronic data base consulted during the international search (name of data base and, where practical, search terms used)

C. DOCUMENTS CONSIDERED TO BE RELEVANT

Category *	Citation of document, with indication, where appropriate, of the relevant passages	Relevant to claim No.
X Y	DE,U,92 15 436 (VMS) 10 February 1994 see page 4, line 5 - line 14 ---	1-4 5-9
X Y	DE,A,41 02 684 (LA FONTAINE) 6 August 1992 see column 4, line 29 - line 38 ---	1-4 5-9
A	EP,A,0 035 040 (CARTER) 9 September 1981 see page 7, line 24 - line 31 -----	5

Further documents are listed in the continuation of box C. Patent family members are listed in annex.

* Special categories of cited documents :

<p>*A* document defining the general state of the art which is not considered to be of particular relevance</p> <p>*E* earlier document but published on or after the international filing date</p> <p>*L* document which may throw doubts on priority claim(s) or which is cited to establish the publication date of another citation or other special reason (as specified)</p> <p>*O* document referring to an oral disclosure, use, exhibition or other means</p> <p>*P* document published prior to the international filing date but later than the priority date claimed</p>	<p>*T* later document published after the international filing date or priority date and not in conflict with the application but cited to understand the principle or theory underlying the invention</p> <p>*X* document of particular relevance; the claimed invention cannot be considered novel or cannot be considered to involve an inventive step when the document is taken alone</p> <p>*Y* document of particular relevance; the claimed invention cannot be considered to involve an inventive step when the document is combined with one or more other such documents, such combination being obvious to a person skilled in the art.</p> <p>* & * document member of the same patent family</p>
--	--

Date of the actual completion of the international search <p style="text-align: center;">9 January 1997</p>	Date of mailing of the international search report <p style="text-align: center;">20. 01. 97</p>
--	---

Name and mailing address of the ISA European Patent Office, P.B. 5818 Patentlaan 2 NL - 2280 HV Rijswijk Tel. (+ 31-70) 340-2040, Tx. 31 651 epo nl, Fax: (+ 31-70) 340-3016	Authorized officer <p style="text-align: center;">Glas, J</p>
--	--

INTERNATIONAL SEARCH REPORT

International Application No

PCT/GB 96/02395

Patent document cited in search report	Publication date	Patent family member(s)	Publication date
DE-U-9215436	10-02-94	NONE	
-----	-----	-----	-----
DE-A-4102684	06-08-92	NONE	
-----	-----	-----	-----
EP-A-35040	09-09-81	NONE	
-----	-----	-----	-----