

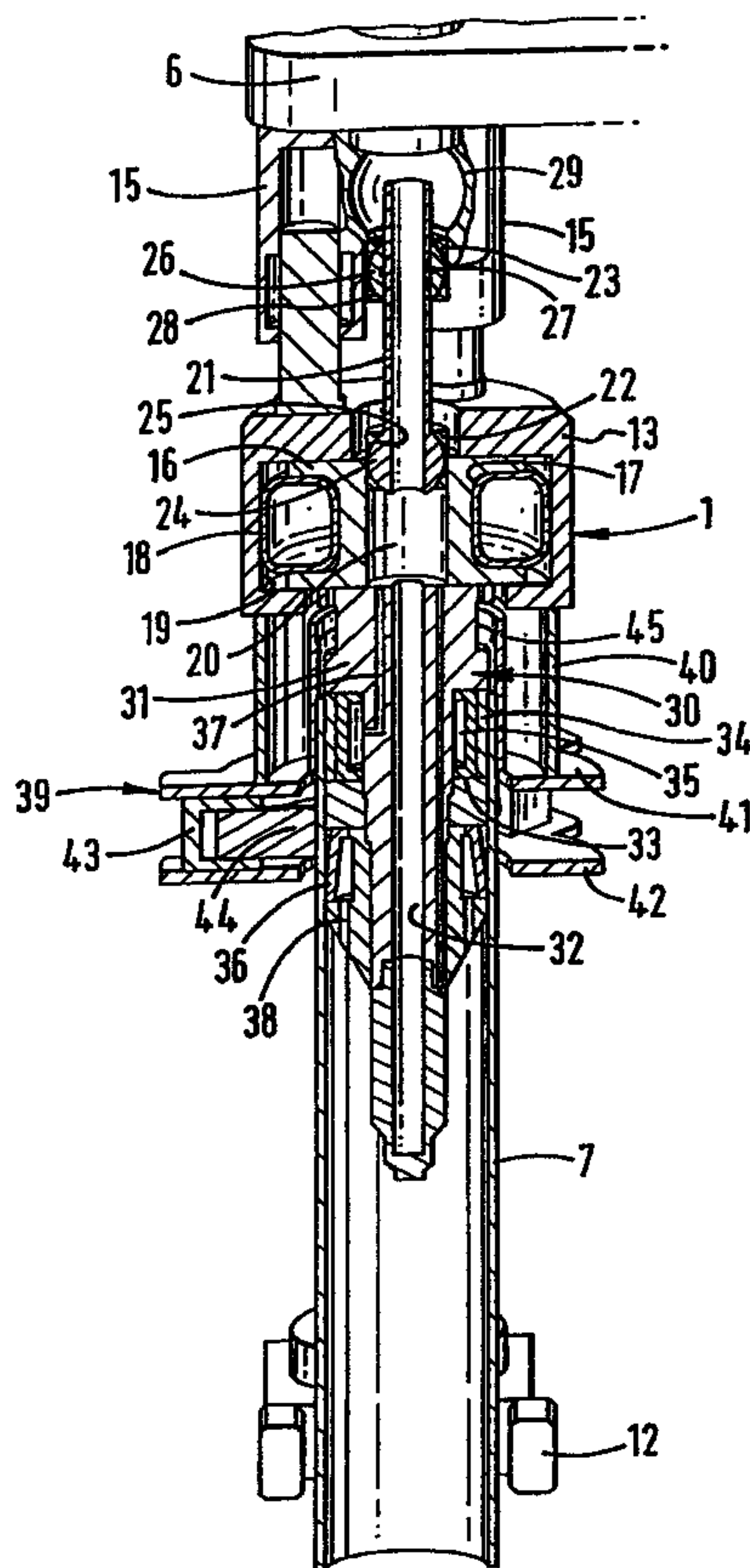

(86) Date de dépôt PCT/PCT Filing Date: 1999/11/29
 (87) Date publication PCT/PCT Publication Date: 2000/07/06
 (45) Date de délivrance/Issue Date: 2007/01/09
 (85) Entrée phase nationale/National Entry: 2001/06/26
 (86) N° demande PCT/PCT Application No.: GB 1999/003951
 (87) N° publication PCT/PCT Publication No.: 2000/039430
 (30) Priorité/Priority: 1998/12/24 (GB9828673.5)

(51) Cl.Int./Int.Cl. *E21B 19/16* (2006.01),
E21B 21/10 (2006.01)
 (72) Inventeur/Inventor:
PIETRAS, BERND-GEORG, DE
 (73) Propriétaire/Owner:
WEATHERFORD/LAMB, INC., US
 (74) Agent: MARKS & CLERK

(54) Titre : APPAREIL ET PROCEDE FACILITANT LE RACCORDEMENT DE PIECES TUBULAIRES AU MOYEN D'UNE TRANSMISSION SUPERIEURE
 (54) Title: APPARATUS AND METHOD FOR FACILITATING THE CONNECTION OF TUBULARS USING A TOP DRIVE



(57) Abrégé/Abstract:

An apparatus for facilitating the connection of tubulars using a top drive, the apparatus comprising a supporting member (13) for connection with said top drive, a tool (30) for gripping a tubular and means for allowing substantially horizontal movement therebetween, wherein said means comprises a flexible membrane (18) enclosing a fluid.

PCTWORLD INTELLECTUAL PROPERTY ORGANIZATION
International Bureau

INTERNATIONAL APPLICATION PUBLISHED UNDER THE PATENT COOPERATION TREATY (PCT)

<p>(51) International Patent Classification ⁷ : E21B 19/16, 21/10</p>	<p>A1</p>	<p>(11) International Publication Number: WO 00/39430</p> <p>(43) International Publication Date: 6 July 2000 (06.07.00)</p>
<p>(21) International Application Number: PCT/GB99/03951</p> <p>(22) International Filing Date: 29 November 1999 (29.11.99)</p> <p>(30) Priority Data: 9828673.5 24 December 1998 (24.12.98) GB</p> <p>(71) Applicant (for all designated States except US): WEATHER-FORD/LAMB, INC. [US/US]; CSC - The United States Corporation Company, 1013 Centre Road, Wilmington, DE 19805 (US).</p> <p>(71) Applicant (for GB only): HARDING, Richard, Patrick [GB/GB]; Marks & Clerk, 4220 Nash Court, Oxford Business Park South, Oxford OX4 2RU (GB).</p> <p>(72) Inventor; and (75) Inventor/Applicant (for US only): PIETRAS, Bernd-Georg [DE/DE]; Sandriedeweg 12, D-3001 Wedemark 2 (DE).</p> <p>(74) Agent: LIND, Robert; Marks & Clerk, 4220 Nash Court, Oxford Business Park South, Oxford, OX4 2RU (GB).</p>	<p>(81) Designated States: AU, CA, GB, NO, US, European patent (AT, BE, CH, CY, DE, DK, ES, FI, FR, GB, GR, IE, IT, LU, MC, NL, PT, SE).</p> <p>Published With international search report.</p>	

(54) Title: APPARATUS AND METHOD FOR FACILITATING THE CONNECTION OF TUBULARS USING A TOP DRIVE

(57) Abstract

An apparatus for facilitating the connection of tubulars using a top drive, the apparatus comprising a supporting member (13) for connection with said top drive, a tool (30) for gripping a tubular and means for allowing substantially horizontal movement therebetween, wherein said means comprises a flexible membrane (18) enclosing a fluid.

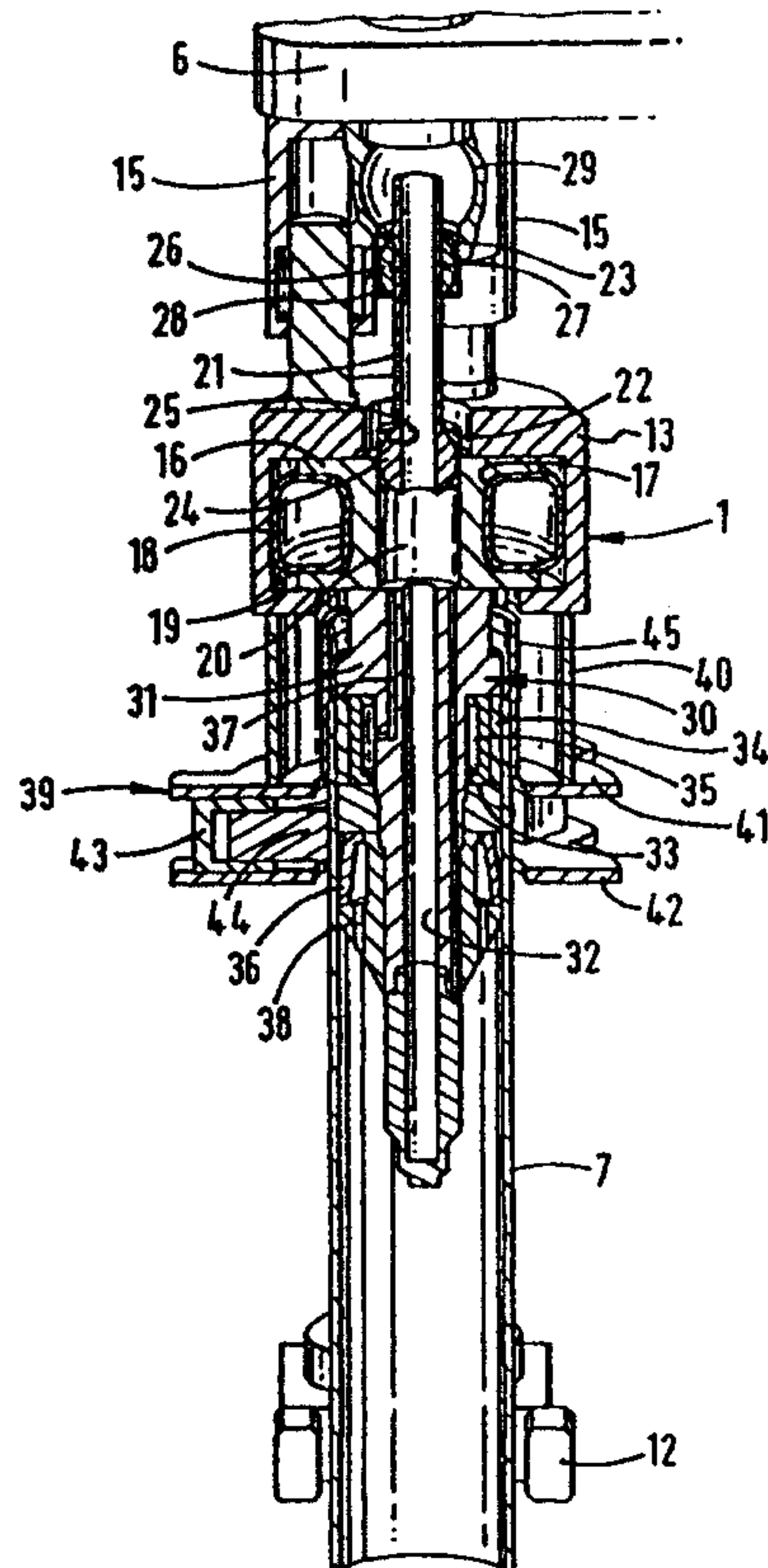

WO 00/39430

PCT/GB99/03951

Apparatus and Method for Facilitating the
Connection of Tubulars Using a Top Drive

This invention relates to an apparatus and method for facilitating the connection of tubulars using a top drive and is, more particularly but not exclusively, intended for facilitating the connection of a section or stand of casing to a string of casing.

In the construction of oil or gas wells it is usually necessary to line the borehole with a string of tubulars known as casing. Because of the length of the casing required, sections or stands of say two or three sections of casing are progressively added to the string as it is lowered into the well from a drilling platform. In particular, when it is desired to add a section or stand of casing the string is usually restrained from falling into the well by applying the slips of a spider located in the floor of the drilling platform. The new section or stand of casing is then moved from a rack to the well centre above the spider. The threaded pin of the section or stand of casing to be connected is then located over the threaded box of the casing in the well and the connection is made up by rotation therebetween. An elevator is then connected to the top of the new section or stand and the whole casing string lifted slightly to enable the slips of the spider to be released. The whole casing string is then lowered until the top of the section is adjacent the spider whereupon the slips of the spider are re-applied, the elevator disconnected and the process repeated.

It is common practice to use a power tong to torque the connection up to a predetermined torque in order to make the connection. The power tong is located on the platform, either on rails, or hung from a derrick on a chain. However, it has recently been proposed to use a top drive for making such connection.

- 2 -

Because of the high costs associated with the construction of oil and gas wells time is critical and it has been observed by the applicants that the time to connect a tubular to a top drive using existing equipment
5 could be reduced.

It has been observed that sections or stands of tubulars are often not as uniform as desired. In particular, the sections or stands of tubulars are often not straight. The top drive is in perfect alignment with
10 the centre of the spider in the platform of an oil or gas rig. However, a section or stand of tubulars located in the spider would not always be in alignment with the top drive.

There is described an apparatus and method for
15 facilitating the connection of tubulars using a top drive in co-pending UK Patent Application No. 98 18363.5, which apparatus comprises a stator attachable to the top drive and a supporting member for supporting a tool wherein means are provided to allow substantially horizontal
20 movement of said supporting member.

The apparatus disclosed therein is bulky, cumbersome and awkward to use. The present invention attempts to reduce these problems.

Accordingly, there is provided an apparatus for
25 facilitating the connection of tubulars using a top drive, the apparatus comprising a supporting member for connection with said top drive, a tool for gripping a tubular and means for allowing substantially horizontal movement therebetween wherein said means comprises a
30 flexible membrane enclosing a fluid.

2a

In one embodiment, the fluid is a pneumatic fluid or a hydraulic fluid. The flexible membrane can be sealed. A feed line can be connected to said flexible membrane to adjust the pressure of the pneumatic fluid therein. Alternatively, a feed line is connected to said flexible membrane for the passage of hydraulic fluid thereto and therefrom.

The flexible membrane, in use, can be in frictional engagement with said tool and said supporting member. The flexible membrane can comprise an inflatable ring. The supporting member can comprise an external housing. The tool can comprise a hub about which said flexible membrane is arranged. The tool can grip said tubular from the inside thereof. The tool can comprise a sealing ring for use with circulating fluids in said tubular, and can further comprise an external clamp fixed to the supporting member for transferring high torques to said tubular. The external clamp can comprise at least one piston and cylinder for gripping said tubular. The external clamp can comprise a plurality of piston and cylinders for, in use, moving said tubular into alignment with said top drive. The supporting member can be, in use, attached to said top drive via piston and cylinders to allow small substantially vertical movements.

There is also provided a method for facilitating the connection of tubulars, the method comprising the steps of moving a tool for gripping a tubular substantially in

WO 00/39430

PCT/GB99/03951

- 3 -

a horizontal plane relative to a supporting member
whereupon a flexible membrane located therebetween is
deformed.

- 4 -

For a better understanding of the present invention, reference will now be made, by way of example, to the accompanying drawings, in which:-

Figure 1 is a view in perspective of an apparatus
5 according to the invention, the apparatus being shown in use;

Figure 2 is a front plan view of the apparatus of Figure 1, the apparatus being shown in use;

Figure 3 is an enlarged cross-sectional view of
10 parts of Figure 1.

Referring to the drawings, there is shown an apparatus for facilitating the connection of tubulars using a top drive. The apparatus is generally identified by reference numeral 1.

15 The apparatus 1 is shown connected to a rotor 2 of a top drive 3 via connection 4 to a rotor 5 of the apparatus 1. The top drive 3 is located on rails on a derrick of a rig (not shown). A rigid member 6 is fast with a static part of the top drive 3. The rigid member
20 surrounds the rotor 5. The rigid member 6 has a clamp therein which, when required, applies jaws (not shown) to the rotor 5 such that, upon rotation of the rotor 2 of the top drive 3, the apparatus 1 may be connected or
25 disconnected from the top drive 3. When the jaws are released, the rotor 5 may rotate freely within the rigid member 6.

The apparatus 1 is shown with a stand of casing 7 inserted therein. An elevator 8 is shown gripping the stand of casing 7 with the use of gripping elements 9.
30 The elevator 8 is suspended from the top drive 3 on bails 10 and 11. The stand of casing 7 is guided by a pipe handling arm 12.

The apparatus 1 comprises a housing 13 which depends from the rotor 5 via a supporting element 14 and three
35 piston and cylinders 15. The three piston and cylinders

WO 00/39430

PCT/GB99/03951

- 5 -

15 allow small vertical movements of the apparatus 1 relative to the top drive 3. The three piston and cylinders 15 may be hydraulically activated or pneumatically activated or using a combination of both pneumatic and hydraulic fluids.

5 The housing 13 accommodates a hub 16 which is radially and rotationally moveable therein. The hub 16 has a circumferential recess 17 into which an inflatable ring 18 is arranged. The inflatable ring 18 is in frictional engagement with both the hub 16 and an internal wall 19 of the housing 13. The hub 16 has a central bore 20 into which one end of a mud pipe 21 is inserted. The mud pipe 21 is provided for carrying mud to the inside of the tubular 7. The mud pipe 21 is mounted in cylindrical sections 22 and 23 which are attached to the hub 16 and the supporting element 14 respectively. The mud pipe 21 is provided with a lobe 24 formed on the outer surface thereof and is located in a corresponding recess 25 in the cylindrical section 22. A lobe 26 is slidably arranged on the upper end of the mud pipe 21 with an o-ring seal 27 arranged therebetween to inhibit fluid from leaking therebetween. The lobe 26 is located in a corresponding recess 28 in the cylindrical section 23. This arrangement allows a ball and socket type movement between the supporting element 14 and the hub 16 and relative longitudinal movement therebetween. The upper end of the mud pipe 21 is allowed to move freely in a spherical recess 29 in the supporting element 14.

30 A circulating tool generally identified by reference numeral 30 is fixed to and depends from the hub 16. The circulating tool 30 comprises a cylindrical body 31 which has a central passage 32 therethrough. The cylindrical body 31 has a plurality of recesses 33 thereabout in which gripping elements 34 are located. The gripping

35

- 6 -

elements 34 are provided with recesses 35.

The cylindrical body 31 is also provided with an inflatable sealing ring 36 arranged below the gripping elements 34.

5 The cylindrical body 31 is provided with a feed passage 37 the upper end of which is connected to a hydraulic fluid supply and at the other end to the recesses 35 in the gripping elements 34. A feed passage 38 connects the inflatable sealing ring 36 with the
10 inside of the tubular 7.

A clamping device 39 depends from the housing 13 on a rigid cylinder 40. The clamping device 39 comprises two rigid plates 41 and 42 between which is arranged three hydraulic pistons 43 spaced at 120° to each other.
15 The hydraulic pistons 43 are provided with gripping elements 44 for engaging with the tubular 7.

In use, the apparatus 1 is fitted to the rotor 2 of a top drive 3 via the rotor 5 of the apparatus 1. When it is desired to connect a stand of tubulars such as
20 casing to a string of casing already lowered into a wellbore and suspended from a spider in the rig floor (not shown), the following steps are performed.

A stand of casing is moved from a storage area to the well centre, and is gripped by the pipe handling arm
25 12. The pipe handling arm 12, if necessary, moves the stand of casing to a position where the apparatus 1 may be lowered onto the top of the stand of casing. The apparatus 1 is lowered with the top drive 3 on the rails on the derrick of the rig. As the apparatus 1 is
30 lowered, the circulating tool 30 inserts itself inside the stand of casing and the clamping device 39 passes over the box 45 of the casing 7.

The gripping elements 34 are moved radially outwardly by the hydraulic fluid pressure build up
35 through feed passage 37 and into recess 35. The gripping

- 7 -

elements engage with the internal wall of the casing 7. It should be noted that the weight of the stand of casing may now be taken by the gripping elements 34. The pipe handling arm 12 can now move the stand of casing into exact alignment with the box of the casing string protruding above the spider in the rig floor. This step is necessary due to the stands of casing being slightly bent. As the stand of casing 7 moves, the circulating tool 30 moves with the casing 7. The pneumatic fluid in the inflatable ring 18 allows relative movement between the stationary top drive 3 and circulating tool and hence the casing 7. Once aligned, the stand of casing is lowered ("stabbed") into the box of the casing string by activation of piston and cylinders 15. Low torque rotation of the stand of casing now begins by rotation of the top drive rotor 2. It should be noted that the inflatable ring 18 helps accommodate non-linearity in the casing 7 since it allows the top of the casing 7 to float with respect to the longitudinal axis of the top drive 3 whilst being rotated to engage the pin of the casing 7 in the box of the casing string held in the spider in the rig floor. The low torque is transferred from the rotor 2 of the top drive through the piston and cylinders 15, through the housing 13 and via the inflatable ring 18 to the circulating tool 30 and hence to the stand of casing 7 via the gripping elements 34. The threaded pin of the stand of casing 7 is now partially made up with the threaded box of the casing string. The pipe handling arm 12 may now be removed from the casing 7 and swung into an inoperative position. The three piston and cylinders 43 of the clamping device are now activated evenly which moves the top of the stand of casing 7 and the circulating tool 30 into exact alignment with the top drive. The top drive may now be used to complete make-up by rotating the stand of casing typically up to 95,000Nm

WO 00/39430

PCT/GB99/03951

- 8 -

(70,000lb/ft) of torque. The high torque is transferred from the top drive 3 through piston and cylinders 15 through the housing 13, the rigid cylinder 40 and the clamping device 39 and hence to the stand of casing 7.

5 The spider may be used to hold the casing string 7 against rotation while this operation is carried out.

The elevator 8 may now be swung around the top of the casing 7. Circulation may now take place. Any pressure build up in the casing 7 would force the
10 inflatable sealing ring 36 out and into engagement with the casing wall due to pressure build up through the feed passage 38. Circulating fluid may be pumped in to the casing string through mud pipe 19, central bore 20 and central passage 32.

15 The spider may be released allowing the elevator 8 to take the weight of the casing string. The elevator 8 may lower the casing string into the wellbore. During lowering the top drive 3 may continue to rotate the apparatus 1 and hence rotate the casing string at up to
20 95,000Nm (70,000lbs/ft) of torque, if required.

The apparatus 1 may be removed by deactivating the piston and cylinders 43 of the clamping device 39, the gripping elements 34 of the circulating tool 30, deflating the inflatable sealing ring 36 and lifting the
25 apparatus 1 by raising the top drive 3.

A reverse sequence may be used to disconnect stands or single pieces of casing from a casing string.

It is envisaged that various modifications or variations may be made to the above described embodiment.
30 In particular, the inflatable ring 18 may contain pneumatic fluid and be sealed. Alternatively, the inflatable ring 18 may be provided with a pneumatic supply line for controlling the pressure of the pneumatic fluid therein, for example for lowering the pressure when
35 aligning the casing. The inflatable ring 18 may contain

- 9 -

hydraulic fluid and be provided with a waste gate or a supply line for controlling the quantity of hydraulic fluid therein. A combination of both hydraulic and pneumatic fluids may be used preferably using hydraulic fluid in the inflatable ring and pneumatic bellows.

5 The inflatable ring may be a vehicle tyre.

It is envisaged that in certain embodiments the apparatus 1 may not be directly linked to the top drive 3. In particular, a motor, advantageously a hydraulic motor, may be inserted between the top drive 3 and the apparatus 1 for providing accurate speed of rotation and control for making up the casing.

It is envisaged that the apparatus 1 could be used for rotating the casing while lowering the casing. Reciprocation of the casing may also be provided simultaneously by raising and lowering the elevator.

It is envisaged that the casing string may be provided with a drilling bit as its lower end. The apparatus 1 may be used, with the clamping device 39 actuated, to rotate the casing and hence the drill bit, for drilling a wellbore.

It is conceivable that the clamping device 39 could be dispensed with and the entire torque from the top drive transmitted through the inflatable ring 18, particularly if highly pressurized with hydraulic fluid at the time it is desired to transmit high torque.

It is also envisaged that any suitable mechanism and method of actuation could be used for external clamping. For example, the mechanism could comprise cam surfaces with rough material thereon. The method of actuation could be mechanical, electrical, pneumatic, hydraulic or chemical. A design from a power tong may be suitable for this purpose.

The embodiments of the present invention in which an exclusive property or privilege is claimed are defined as follows:

1. An apparatus for facilitating the connection of tubulars using a top drive, the apparatus comprising a supporting member for connection with said top drive, a tool for gripping a tubular and means for allowing substantially horizontal movement therebetween, wherein said means comprises a flexible membrane enclosing a fluid.
2. An apparatus as claimed in claim 1, wherein said fluid is a pneumatic fluid.
3. An apparatus as claimed in claim 2, wherein a feed line is connected to said flexible membrane to adjust the pressure of the pneumatic fluid therein.
4. An apparatus as claimed in claim 1, 2 or 3, wherein said flexible membrane is sealed.
5. An apparatus as claimed in claim 1, wherein said fluid is a hydraulic fluid.
6. An apparatus as claimed in claim 5, wherein a feed line is connected to said flexible membrane for the passage of hydraulic fluid thereto and therefrom.
7. An apparatus as claimed in any one of claims 1 to 6, wherein said flexible membrane comprises an inflatable ring.

8. An apparatus as claimed in any one of claims 1 to 7, wherein said supporting member comprises an external housing.
9. An apparatus as claimed in any one of claims 1 to 8, wherein said tool comprises a hub about which said flexible membrane is arranged.
10. An apparatus as claimed in any one of claims 1 to 9, wherein said tool grips said tubular from the inside thereof.
11. An apparatus as claimed in claim 10, wherein said tool comprises a sealing ring for use with circulating fluids in said tubular.
12. An apparatus as claimed in claim 10 or 11, further comprising an external clamp fixed to the supporting member for transferring high torques to said tubular.
13. An apparatus as claimed in claim 12, wherein said external clamp comprises at least one piston and cylinder for gripping said tubular.
14. An apparatus as claimed in claim 12 or 13, wherein said external clamp comprises a plurality of pistons and cylinders for, in use, moving said tubular into alignment with said top drive.
15. An apparatus as claimed in any one of claims 1 to 14, wherein said supporting member is, in use, attached to said top drive via piston and cylinders to allow small substantially vertical movements.

16. A method for facilitating the connection of tubulars, the method comprising the steps of moving a tool for gripping a tubular substantially in a horizontal plane relative to a supporting member whereupon a flexible membrane located therebetween is deformed.

17. An apparatus for facilitating the connection of a first tubular with a second tubular using a top drive, comprising:

- a housing coupled to the top drive;
- a hub movably disposed in the housing; and
- a gripping member coupled to the hub for engagement with the first tubular,

wherein the hub is adapted to allow relative horizontal movement between the gripping member and the top drive to align the first tubular with the second tubular for connection therewith.

18. The apparatus of claim 17, further comprising a flexible membrane disposed between the hub and the housing.

19. The apparatus of claim 18, wherein the flexible membrane is inflatable.

20. The apparatus of claim 18 or 19, wherein the flexible membrane comprises a pneumatic fluid or a hydraulic fluid.

21. The apparatus of any one of claims 17 to 20, wherein the gripping member is adapted to engage an interior of the first tubular.

22. The apparatus of any one of claims 17 to 20, wherein the gripping member is adapted to engage an exterior of the first tubular.

23. The apparatus of any one of claims 17 to 22, further comprising a second gripping member.

24. The apparatus of any one of claims 17 to 23, further comprising a supporting member for operatively coupling the hub to the top drive.

25. The apparatus of claim 24, further comprising one or more piston and cylinder assemblies.

26. The apparatus of any one of claims 17 to 25, further comprising a fluid tubular arranged to provide fluid communication between the hub and the top drive.

27. A method for connecting a first tubular to a second tubular using a top drive, comprising:

coupling a gripping member to the top drive;

engaging a first tubular;

moving the gripping member radially relative to a central axis of the top drive to align the first tubular with the second tubular;

rotating the gripping member to connect the first and second tubulars.

28. The method of claim 27, further comprising:

operatively connecting a housing to the top drive;

disposing a hub in the housing; and

attaching the gripping member to the hub.

29. The method of claim 28, wherein the hub is radially movable.

30. The method of claim 28 or 29, further comprising disposing a flexible member between the hub and the housing.

31. The method of claim 28, 29 or 30, wherein the hub is movable relative to the top drive.

32. The method of any one of claims 27 to 31, wherein engaging the first tubular comprises engaging an interior of the first tubular.

33. A method of drilling with casing using a top drive, comprising:

 providing a casing having a drilling member disposed at a first end;

 coupling a gripping apparatus to the top drive, the gripping apparatus having a radially movable gripping element adapted to engage a second end of the casing;

 engaging a second end of the casing with the gripping element; and

 actuating the top drive to rotate the casing, thereby rotating the drilling member.

34. The method of claim 33, wherein engaging the second end comprises moving the gripping element radially into engagement with the second end.

35. The method of claim 33 or 34, wherein the gripping apparatus is adapted to engage an interior surface of the casing.

36. The method of claim 33 or 34, wherein the gripping apparatus is adapted to engage an exterior surface of the casing.

37. The method of any one of claims 33 to 36, wherein the gripping element is actuated using a hydraulic fluid.

38. The method of any one of claims 33 to 37, further comprising connecting a second casing to the casing.

39. The method of claim 38, further comprising aligning the second casing with the casing.

40. The method of claim 39, further comprising moving the gripping apparatus in a substantially horizontal plane relative to the top drive to align the second casing with the casing.

41. The method of any one of claims 33 to 40, further comprising providing an adapter to couple the gripping apparatus to the top drive.

42. The method of claim 41, wherein the adapter allows relative horizontal movement between the gripping apparatus and the top drive to align the second casing with the casing for connection therewith.

43. The method of claim 41 or 42, wherein the adapter comprises a hub disposed in a housing.

44. The method of claim 43, wherein the adapter further comprises a flexible membrane disposed between the hub and the housing.

45. A method of connecting a first casing to a second casing using a top drive, comprising:

coupling a gripping apparatus to the top drive, the gripping apparatus having a radially movable gripping element adapted to engage the first casing;

actuating the gripping element to engage the first casing;

aligning the first casing with the second casing;

actuating the top drive to rotate the first casing relative to the second casing; and

connecting the first casing to the second casing.

46. The method of claim 45, wherein engaging the first casing comprises moving the gripping element radially into engagement with the first casing.

47. The method of claim 45 or 46, wherein the gripping element engages an interior surface of the first casing.

48. The method of claim 45 or 46, wherein the gripping element engages an exterior surface of the first casing.

49. The method of any one of claims 45 to 48, wherein aligning the first casing to the second casing comprises moving the gripping apparatus in a substantially horizontal plane relative to the top drive.

50. The method of any one of claims 45 to 49, further comprising rotating the first casing and the second casing to form a borehole.

51. The method of any one of claims 45 to 50, wherein the gripping apparatus comprises a circulating tool.

52. The method of any one of claims 45 to 51, wherein the gripping apparatus comprises a sealing member actuatable by a fluid pressure in the first casing.

53. The method of any one of claims 45 to 52, wherein the gripping apparatus is adapted to engage an exterior surface of the first casing.

54. The method of claim 53, further comprising a second gripping apparatus adapted to engage an interior surface of the first casing.

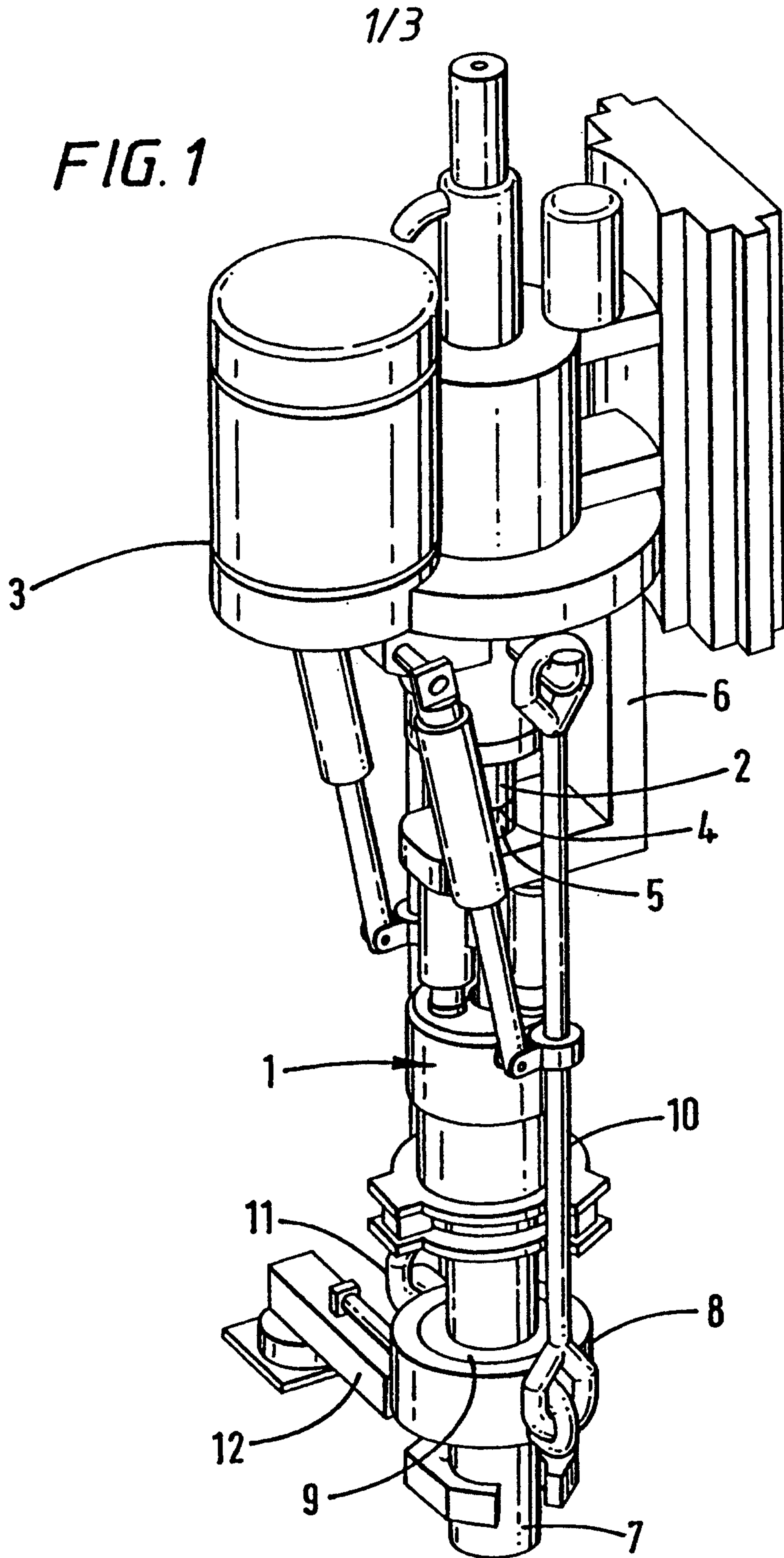

2/3

FIG. 2

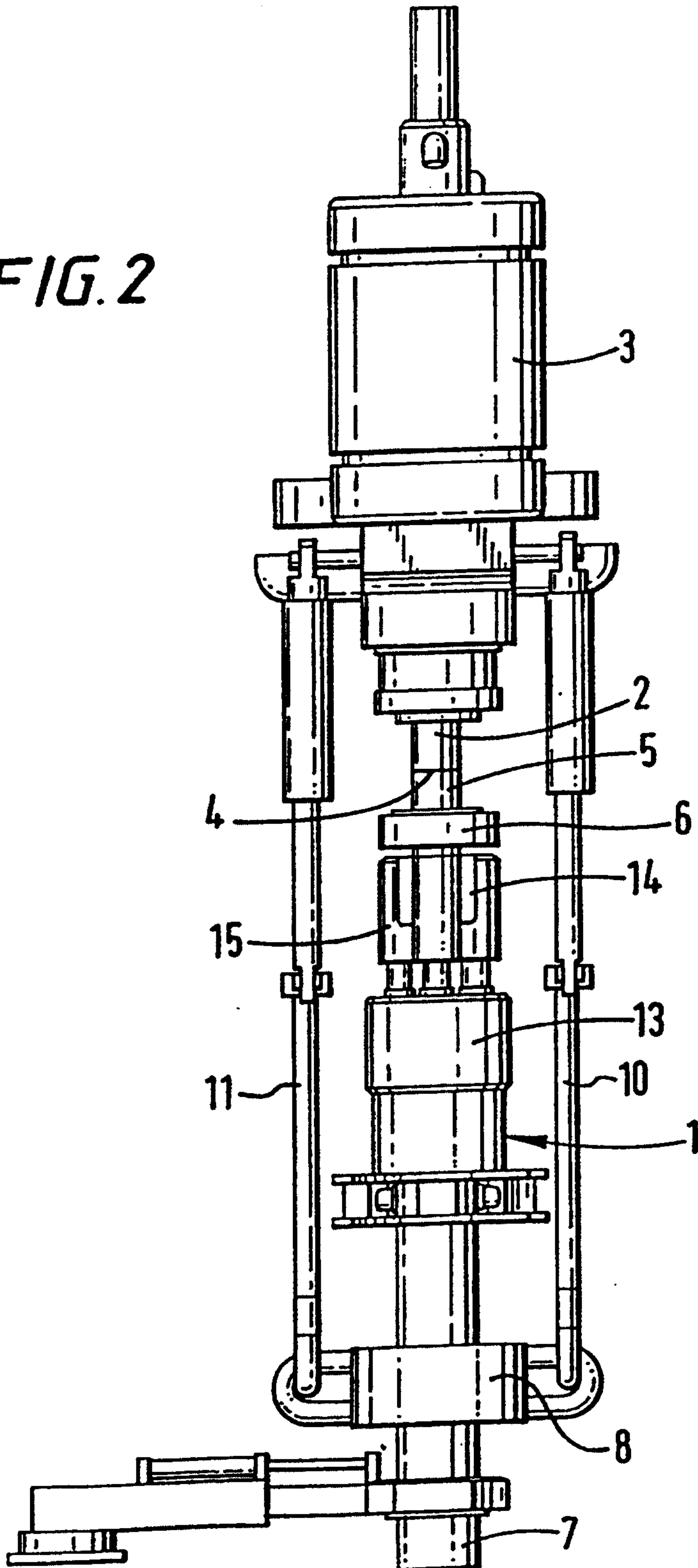

Marks & Clerk

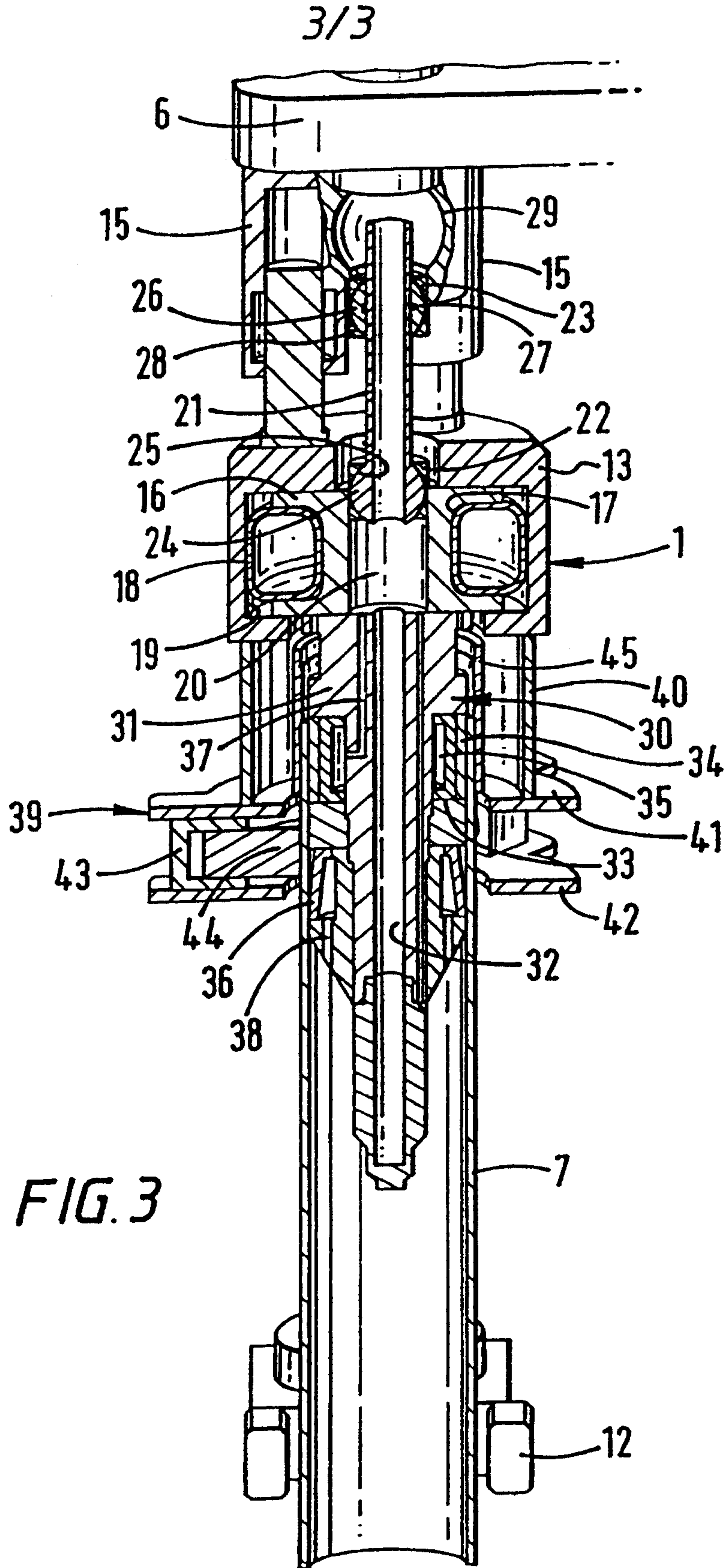

Marks & Clerk

